

Doc 8168
OPS/611



Procedures for
Air Navigation Services

Aircraft Operations

Volume II
Construction of Visual and
Instrument Flight Procedures

This edition incorporates all amendments approved by the Council prior to 23 April 2014 and supersedes, on 13 November 2014, all previous editions of Doc 8168, Volume II.

Sixth edition – 2014

International Civil Aviation Organization

Doc 8168
AN/611



Procedures for
Air Navigation Services

Aircraft Operations

Volume II
**Construction of Visual and
Instrument Flight Procedures**

**This edition incorporates all amendments
approved by the Council prior to 23 April 2014
and supersedes, on 13 November 2014,
all previous editions of Doc 8168, Volume II.**

Sixth Edition — 2014

International Civil Aviation Organization

Published in separate English, French, Russian and Spanish editions by the
INTERNATIONAL CIVIL AVIATION ORGANIZATION
999 University Street, Montréal, Quebec, Canada H3C 5H7

For ordering information and for a complete listing of sales agents
and booksellers, please go to the ICAO website at www.icao.int

First edition 1961
Fifth edition 2006
Sixth edition 2014

**Doc 8168, *Procedures for Air Navigation Services — Aircraft Operations*
Volume II, *Construction of Visual and Instrument Flight Procedures***

Order Number: 8168-2

ISBN 978-92-9249-637-1

© ICAO 2014

All rights reserved. No part of this publication may be reproduced, stored in a
retrieval system or transmitted in any form or by any means, without prior
permission in writing from the International Civil Aviation Organization.

TABLE OF CONTENTS

	<i>Page</i>
FOREWORD	(xix)
PART I. GENERAL	I-(i)
Section 1. Definitions, abbreviations and acronyms and units of measurement	I-1-(i)
Chapter 1. Definitions	I-1-1-1
Chapter 2. Abbreviations and acronyms	I-1-2-1
Chapter 3. Units of measurement.....	I-1-3-1
Chapter 4. Frame of reference.....	I-1-4-1
Section 2. General principles	I-2-(i)
Chapter 1. General	I-2-1-1
1.1 Introduction	I-2-1-1
1.2 Areas	I-2-1-2
1.3 Obstacle clearance.....	I-2-1-2
1.4 Example calculations.....	I-2-1-2
1.5 Bearings, tracks and radials.....	I-2-1-3
1.6 Navigation system use accuracy.....	I-2-1-3
1.7 Increased altitudes/heights for mountainous areas	I-2-1-3
1.8 Area minimum altitude (AMA).....	I-2-1-3
1.9 Charting accuracy.....	I-2-1-4
1.10 Presentation of significant obstacles and spot elevations on charts.....	I-2-1-4
1.11 Aircraft characteristics database.....	I-2-1-4
1.12 Promulgation	I-2-1-4
Appendix to Chapter 1. Conversion table for IAS to TAS calculations.....	I-2-1-App-1
Chapter 2. Terminal area fixes	I-2-2-1
2.1 General	I-2-2-1
2.2 Terminal area fixes.....	I-2-2-1
2.3 Fix tolerance and fix tolerance area for intersecting fixes.....	I-2-2-1
2.4 Fix tolerance for other types of navigation instruments	I-2-2-2
2.5 Fix tolerance overheading a station.....	I-2-2-3
2.6 Operational application of fixes for flight procedure planning	I-2-2-4
2.7 Use of fixes for descent and related obstacle clearance.....	I-2-2-6
2.8 Protection area for VOR and NDB.....	I-2-2-7

	<i>Page</i>
Chapter 3. Turn area construction	I-2-3-1
3.1 General	I-2-3-1
3.2 Turn inner boundary construction	I-2-3-2
3.3 Turn outer boundary construction	I-2-3-2
Chapter 4. Quality assurance.....	I-2-4-1
4.1 General	I-2-4-1
4.2 The instrument flight procedure process	I-2-4-1
4.3 Procedure design information acquisition	I-2-4-1
4.4 Procedure design	I-2-4-2
4.5 Procedure design documentation.....	I-2-4-2
4.6 Ground and flight validation	I-2-4-3
4.7 Procedure designer qualifications and training.....	I-2-4-4
4.8 Procedure design automation	I-2-4-5
Section 3. Departure procedures	I-3-(i)
Chapter 1. Introduction to departure procedures.....	I-3-1-1
1.1 General	I-3-1-1
1.2 Consultation	I-3-1-1
1.3 Standardization.....	I-3-1-1
1.4 Economy	I-3-1-1
1.5 Routes	I-3-1-1
1.6 Related material.....	I-3-1-2
1.7 Abnormal and emergency operations.....	I-3-1-2
Chapter 2. General concepts for departure procedures.....	I-3-2-1
2.1 Establishment of a departure procedure	I-3-2-1
2.2 Design principles.....	I-3-2-1
2.3 Beginning of the departure procedure	I-3-2-2
2.4 End of the departure procedure	I-3-2-2
2.5 Minimum obstacle clearance (MOC)	I-3-2-2
2.6 Obstacle identification surface (OIS)	I-3-2-3
2.7 Procedure design gradient (PDG).....	I-3-2-3
2.8 Average flight path.....	I-3-2-3
2.9 Charting accuracy.....	I-3-2-4
2.10 Additional specific height/distance information.....	I-3-2-4
Chapter 3. Departure routes	I-3-3-1
3.1 General	I-3-3-1
3.2 Straight departures.....	I-3-3-1
3.3 Turning departures	I-3-3-3
Appendix to Chapter 3. Guidance on environmental issues	I-3-3-App-1

	<i>Page</i>
Chapter 4. Omnidirectional departures	I-3-4-1
4.1 General	I-3-4-1
4.2 Areas	I-3-4-1
4.3 Obstacle identification.....	I-3-4-2
4.4 Obstacle clearance.....	I-3-4-2
Chapter 5. Published information for departure procedures.....	I-3-5-1
5.1 General	I-3-5-1
5.2 Omnidirectional departures	I-3-5-1
5.3 Charted altitudes/flight levels.....	I-3-5-2
5.4 Other requirements	I-3-5-2
Chapter 6. Simultaneous operations on parallel or near-parallel instrument runways	I-3-6-1
6.1 Instrument departures from parallel runways	I-3-6-1
6.2 Segregated operations on parallel runways	I-3-6-1
Section 4. Arrival and approach procedures.....	I-4-(i)
Chapter 1. General criteria for approach/arrival procedures	I-4-1-1
1.1 Scope	I-4-1-1
1.2 Procedure construction	I-4-1-1
1.3 Fix names	I-4-1-1
1.4 Segment application	I-4-1-1
1.5 Procedure altitude/height.....	I-4-1-2
1.6 Track guidance	I-4-1-2
1.7 Descent gradients	I-4-1-2
1.8 Categories of aircraft	I-4-1-3
Chapter 2. Arrival segment	I-4-2-1
2.1 Standard instrument arrivals.....	I-4-2-1
2.2 Omnidirectional or sector arrivals	I-4-2-3
Chapter 3. Initial approach segment.....	I-4-3-1
3.1 General	I-4-3-1
3.2 Altitude selection.....	I-4-3-1
3.3 Initial approach segments (other than radar vectors) utilizing straight tracks and DME arcs.....	I-4-3-2
3.4 Initial approach segment using a racetrack procedure.....	I-4-3-3
3.5 Initial approach segment using a reversal procedure.....	I-4-3-4
3.6 Racetrack and reversal procedure areas.....	I-4-3-6
3.7 Maximum descent/nominal outbound timing relationship for a reversal or racetrack procedure	I-4-3-9
3.8 Obstacle clearance.....	I-4-3-9

	<i>Page</i>
Appendix A to Chapter 3. Initial approach using dead reckoning (DR)	I-4-3-App A-1
Appendix B to Chapter 3. Reduction of the width of a straight initial approach area after the IAF and interface between straight initial approach area and reversal procedure areas	I-4-3-App B-1
Appendix C to Chapter 3. Construction of obstacle clearance areas for reversal and holding procedures	I-4-3-App C-1
Chapter 4. Intermediate approach segment	I-4-4-1
4.1 General	I-4-4-1
4.2 Altitude/height selection.....	I-4-4-1
4.3 Intermediate approach segment based on a straight track alignment.....	I-4-4-1
4.4 Intermediate segment within a reversal or racetrack procedure	I-4-4-3
Chapter 5. Final approach segment	I-4-5-1
5.1 General	I-4-5-1
5.2 Alignment.....	I-4-5-1
5.3 Descent gradient.....	I-4-5-2
5.4 Obstacle clearance altitude/height (OCA/H).....	I-4-5-4
5.5 Promulgation	I-4-5-8
Appendix A to Chapter 5. Calculations for OCA/H in non-aligned straight-in approaches.....	I-4-5-App A-1
Appendix B to Chapter 5. Non-precision approaches: steep angle approaches	I-4-5-App B-1
Chapter 6. Missed approach segment.....	I-4-6-1
6.1 General	I-4-6-1
6.2 Climb gradient and MOC	I-4-6-3
6.3 Straight missed approach.....	I-4-6-5
6.4 Turning missed approach	I-4-6-6
6.5 Promulgation	I-4-6-12
Appendix to Chapter 6. Refined method for calculating MAPt and transitional tolerances for a missed approach point defined by a distance from the FAF.....	I-4-6-App-1
Chapter 7. Visual manoeuvring (circling) area	I-4-7-1
7.1 General	I-4-7-1
7.2 Alignment and area	I-4-7-1
7.3 Obstacle clearance.....	I-4-7-2
7.4 Method for reducing OCA/H.....	I-4-7-3
7.5 Missed approach associated with the visual manoeuvre	I-4-7-3
7.6 Promulgation	I-4-7-3
Appendix to Chapter 7. Visual manoeuvring using prescribed track.....	I-4-7-App-1

	<i>Page</i>
Chapter 8. Minimum sector altitudes (MSA)	I-4-8-1
8.1 General	I-4-8-1
8.2 Obstacles in buffer area	I-4-8-1
8.3 Sector orientation	I-4-8-1
8.4 Combining sectors for adjacent facilities	I-4-8-2
8.5 Sectors centred on a VOR/DME or NDB/DME.....	I-4-8-2
Chapter 9. Charting/AIP.....	I-4-9-1
9.1 General	I-4-9-1
9.2 Charted altitudes/flight levels.....	I-4-9-1
9.3 Arrival	I-4-9-1
9.4 Approach	I-4-9-1
9.5 Procedure naming for arrival and approach charts	I-4-9-3
PART II. CONVENTIONAL PROCEDURES	II-(i)
Section 1. Precision approaches.....	II-1-(i)
Chapter 1. Instrument landing system (ILS)	II-1-1-1
1.1 Introduction	II-1-1-1
1.2 Initial approach segment.....	II-1-1-4
1.3 Intermediate approach segment	II-1-1-4
1.4 Precision segment.....	II-1-1-6
1.5 Missed approach segment.....	II-1-1-14
1.6 Simultaneous precision approaches to parallel or near-parallel instrument runways..	II-1-1-19
1.7 Promulgation	II-1-1-19
Appendix A to Chapter 1. ILS: Turning missed approach associated with a precision approach	II-1-1-App A-1
Appendix B to Chapter 1. ILS or MLS: Steep glide path angle approaches	II-1-1-App B-1
Appendix C to Chapter 1. Determining ILS glide path descent/MLS elevation heights and distances.....	II-1-1-App C-1
Appendix D to Chapter 1. Independent parallel approaches to closely spaced parallel runways	II-1-1-App D-1
Appendix E to Chapter 1. Calculation of obstacle assessment surface height	II-1-1-App E-1
Chapter 2. Offset ILS	II-1-2-1
2.1 Use of ILS CAT I with offset localizer alignment	II-1-2-1
2.2 Obstacle clearance criteria.....	II-1-2-1

	<i>Page</i>
Chapter 3. MLS.....	II-1-3-1
3.1 Introduction	II-1-3-1
3.2 Initial approach segment.....	II-1-3-4
3.3 Intermediate approach segment	II-1-3-5
3.4 Precision segment.....	II-1-3-6
3.5 Missed approach segment.....	II-1-3-15
3.6 Simultaneous precision approaches to parallel or near-parallel instrument runways ..	II-1-3-19
3.7 Promulgation	II-1-3-20
Chapter 4. Offset MLS.....	II-1-4-1
4.1 Use of MLS CAT I with offset azimuth alignment	II-1-4-1
4.2 Obstacle clearance criteria.....	II-1-4-1
Chapter 5. PAR	II-1-5-1
5.1 Arrival phase operations.....	II-1-5-1
5.2 Intermediate approach	II-1-5-1
5.3 Final approach	II-1-5-2
5.4 Missed approach.....	II-1-5-2
5.5 Arrival and initial approach areas and obstacle clearances	II-1-5-2
5.6 Intermediate and final approach area and obstacle clearances	II-1-5-3
5.7 Missed approach area and obstacle clearance	II-1-5-4
Section 2. Non-precision approaches.....	II-2-(i)
Chapter 1. LOC only	II-2-1-1
1.1 General	II-2-1-1
1.2 Intermediate approach	II-2-1-1
1.3 Final approach and missed approach segment.....	II-2-1-1
1.4 Promulgation	II-2-1-2
Chapter 2. MLS azimuth only	II-2-2-1
2.1 General	II-2-2-1
2.2 Intermediate approach	II-2-2-1
2.3 Final approach and missed approach segment.....	II-2-2-1
2.4 Promulgation	II-2-2-2
Chapter 3. VOR or NDB with no FAF.....	II-2-3-1
3.1 General	II-2-3-1
3.2 Initial approach segment.....	II-2-3-1
3.3 Intermediate segment	II-2-3-1
3.4 Final approach segment.....	II-2-3-1
3.5 Descent gradient	II-2-3-2
3.6 Use of stepdown fix.....	II-2-3-2
3.7 Missed approach point (MAPt)	II-2-3-3

	<i>Page</i>
Chapter 4. VOR or NDB with FAF.....	II-2-4-1
4.1 General	II-2-4-1
4.2 Initial approach segment.....	II-2-4-1
4.3 Intermediate approach segment	II-2-4-1
4.4 Final approach segment.....	II-2-4-1
4.5 Missed approach point (MAPt)	II-2-4-2
4.6 Promulgation	II-2-4-3
Chapter 5. DF.....	II-2-5-1
5.1 General	II-2-5-1
5.2 Descent gradient.....	II-2-5-1
5.3 Initial approach segment.....	II-2-5-1
5.4 Intermediate segment	II-2-5-2
5.5 Final approach segment.....	II-2-5-2
5.6 Missed approach segment.....	II-2-5-3
Chapter 6. SRE.....	II-2-6-1
6.1 General	II-2-6-1
6.2 Initial approach segment.....	II-2-6-1
6.3 Intermediate approach segment	II-2-6-2
6.4 Final approach segment.....	II-2-6-3
6.5 Missed approach segment.....	II-2-6-4
Section 3. En-route criteria	II-3-(i)
Chapter 1. VOR and NDB routes.....	II-3-1-1
1.1 General	II-3-1-1
1.2 Obstacle clearance areas.....	II-3-1-1
1.3 Obstacle clearance.....	II-3-1-2
1.4 Construction of areas for VOR and NDB routes	II-3-1-3
1.5 Minimum en-route altitude (MEA)	II-3-1-6
1.6 Promulgation	II-3-1-6
Appendix A to Chapter 1. VOR and NDB routes — Refined method for the construction of obstacle clearance areas	II-3-1-App A-1
Appendix B to Chapter 1. Statistical calculations for primary and secondary areas and their angles of splay.....	II-3-1-App B-1
Section 4. Holding criteria.....	II-4-(i)
Chapter 1. Holding criteria.....	II-4-1-1
1.1 Shape and terminology associated with holding pattern	II-4-1-1
1.2 Entry and holding procedures.....	II-4-1-1

	<i>Page</i>
1.3 Construction of holding areas.....	II-4-1-3
1.4 Special conditions for planning VOR/DME holding procedures and construction of associated areas.....	II-4-1-7
1.5 Promulgation.....	II-4-1-8
Appendix A to Chapter 1. Parameters for holding area construction.....	II-4-1-App A-1
Appendix B to Chapter 1. Determination of additional obstacle clearance requirements for minimum holding levels in areas of high terrain or in mountainous areas.....	II-4-1-App B-1
Attachment to Part II. ILS: Background information on ILS obstacle clearance and on airborne and ground equipment performance values associated with Categories I and II obstacle assessment surfaces used in the mathematical model.....	II-Att-1
PART III. PERFORMANCE-BASED NAVIGATION PROCEDURES.....	III-(i)
Section 1. Underlying principles.....	III-1-(i)
Chapter 1. RNAV concepts.....	III-1-1-1
1.1 General.....	III-1-1-1
1.2 Flight technical error.....	III-1-1-4
1.3 Magnetic bearing on a PBN (RNAV or RNP) route segment.....	III-1-1-4
1.4 Buffer values.....	III-1-1-4
1.5 Obstacle clearance area.....	III-1-1-5
1.6 Fixes.....	III-1-1-6
Chapter 2. GNSS RNAV.....	III-1-2-1
2.1 General.....	III-1-2-1
2.2 XTT, ATT and area semi-width.....	III-1-2-1
Chapter 3. DME/DME RNAV.....	III-1-3-1
3.1 General.....	III-1-3-1
3.2 Airborne and ground equipment requirements for DME/DME procedures.....	III-1-3-1
3.3 DME/DME RNAV system use accuracy.....	III-1-3-1
3.4 Flight technical tolerance.....	III-1-3-2
3.5 System computational tolerance.....	III-1-3-2
3.6 XTT, ATT and area semi-width.....	III-1-3-2
3.7 Navigation aid coverage.....	III-1-3-3
3.8 Validation.....	III-1-3-4
Chapter 4. VOR/DME RNAV.....	III-1-4-1
4.1 General.....	III-1-4-1
4.2 Airborne and ground equipment requirements for VOR/DME procedures.....	III-1-4-1
4.3 VOR/DME RNAV system use accuracy.....	III-1-4-1
4.4 Flight technical tolerance.....	III-1-4-2

	<i>Page</i>
4.5 System computation tolerance.....	III-1-4-2
4.6 XTT, ATT and area semi-width	III-1-4-2
Chapter 5. GBAS RNAV	III-1-5-1
<i>(To be developed)</i>	
Section 2. General criteria.....	III-2-(i)
Chapter 1. Minimum length of a segment limited by two waypoints	III-2-1-1
1.1 General	III-2-1-1
1.2 Determination of the minimum length of the RNAV segment.....	III-2-1-1
1.3 Particular case of the segment: DER — First waypoint	III-2-1-3
1.4 Minimum stabilization distance	III-2-1-3
1.5 Determination of the minimum length of an RNAV segment limited by at least one waypoint that is not a turning waypoint	III-2-1-5
Chapter 2. Turn protection and obstacle assessment.....	III-2-2-1
2.1 General	III-2-2-1
2.2 Circular arc method	III-2-2-2
2.3 Wind spiral/bounding circles method.....	III-2-2-2
2.4 RF turn method.....	III-2-2-4
2.5 Obstacle assessment	III-2-2-6
Chapter 3. RNAV T- or Y-bar procedure construction	III-2-3-1
3.1 General concept.....	III-2-3-1
3.2 Initial approach segment.....	III-2-3-1
3.3 Intermediate approach segment	III-2-3-2
3.4 Final approach segment.....	III-2-3-3
3.5 Missed approach segment.....	III-2-3-3
Chapter 4. Terminal arrival altitude (TAA)	III-2-4-1
4.1 General	III-2-4-1
4.2 Construction	III-2-4-1
4.3 Buffer area.....	III-2-4-1
4.4 TAA stepdown arcs and subsectors.....	III-2-4-2
4.5 Promulgation	III-2-4-2
Chapter 5. Navigation database coding	III-2-5-1
5.1 General	III-2-5-1
5.2 Path terminator types.....	III-2-5-1
5.3 Procedure design application.....	III-2-5-6
Appendix to Chapter 5. Path terminator coding rules	III-2-5-App-1

	<i>Page</i>
Chapter 6. Application of FAS data block for SBAS and GBAS	III-2-6-1
6.1 General	III-2-6-1
6.2 Construction	III-2-6-1
6.3 Required non-FAS data block fields	III-2-6-1
6.4 Quality requirements	III-2-6-2
Appendix A to Chapter 6. FAS data block description for SBAS.....	III-2-6-App A-1
Appendix B to Chapter 6. Encoding of the GBAS FAS data block	III-2-6-App B-1
Section 3. Procedure construction	III-3-(i)
Chapter 1. Departure procedures.....	III-3-1-1
1.1 General	III-3-1-1
1.2 Straight departures.....	III-3-1-1
1.3 Area width at the beginning of the departure	III-3-1-2
1.4 Turning departures	III-3-1-2
Chapter 2. Arrival and approach procedures.....	III-3-2-1
2.1 General	III-3-2-1
2.2 Arrival routes.....	III-3-2-2
2.3 Initial approach segment.....	III-3-2-2
2.4 Intermediate approach segment	III-3-2-3
2.5 Turning missed approach	III-3-2-4
2.6 End of the missed approach segment	III-3-2-4
Chapter 3. Non-precision approach procedures	III-3-3-1
3.1 General	III-3-3-1
3.2 Final approach segment.....	III-3-3-1
3.3 Initial and intermediate missed approach segment.....	III-3-3-2
Chapter 4. APV/Barometric vertical navigation (BARO-VNAV).....	III-3-4-1
4.1 General	III-3-4-1
4.2 Standard conditions	III-3-4-1
4.3 APV segment.....	III-3-4-3
4.4 Determination of OCH for the APV segment.....	III-3-4-6
4.5 Height loss margins	III-3-4-7
4.6 Baro-VNAV approach with offset final approach track alignment	III-3-4-9
4.7 Promulgation	III-3-4-9
Appendix A to Chapter 4. Temperature correction	III-3-4-App A-1
Appendix B to Chapter 4. Algorithm for calculating the height of surface defined by four points in space	III-3-4-App B-1

	<i>Page</i>
Chapter 5. SBAS non-precision approach, approach with vertical guidance and precision approach Category I procedures	III-3-5-1
5.1 Introduction	III-3-5-1
5.2 Initial approach segment.....	III-3-5-2
5.3 Intermediate approach segment	III-3-5-2
5.4 APV or CAT I segment	III-3-5-3
5.5 Missed approach segment.....	III-3-5-6
5.6 Simultaneous ILS/MLS/GBAS/APV SBAS approaches to parallel or near-parallel instrument runways	III-3-5-8
5.7 SBAS approach with offset final approach track alignment.....	III-3-5-9
5.8 SBAS NPA	III-3-5-9
5.9 Promulgation	III-3-5-10
Appendix to Chapter 5. Steep glide path angle approaches up to 6.3 degrees (11 per cent)	III-3-5-App-1
Chapter 6. Precision approach procedures — GBAS.....	III-3-6-1
6.1 Introduction	III-3-6-1
6.2 Initial approach segment.....	III-3-6-4
6.3 Intermediate approach segment	III-3-6-5
6.4 Precision segment.....	III-3-6-6
6.5 Missed approach after the precision segment (final missed approach)	III-3-6-14
6.6 Simultaneous ILS and/or MLS precision approaches to parallel or near-parallel instrument runways	III-3-6-18
6.7 GBAS CAT I with offset azimuth final approach track alignment.....	III-3-6-19
6.8 Promulgation	III-3-6-20
Chapter 7. Holding procedures.....	III-3-7-1
7.1 General	III-3-7-1
7.2 Types of RNAV holding procedures	III-3-7-1
7.3 Entry procedures.....	III-3-7-2
7.4 Fix tolerance	III-3-7-2
7.5 Holding area construction.....	III-3-7-3
7.6 Promulgation of RNAV holding procedures	III-3-7-3
Appendix A to Chapter 7. Construction of obstacle clearance area for VOR/DME, DME/DME and GNSS RNAV holding.....	III-3-7-App A-1
Appendix B to Chapter 7. Example of alternative area navigation (RNAV) holding entries for reduced holding entry areas	III-3-7-App B-1
Chapter 8. En-route procedures.....	III-3-8-1
8.1 General	III-3-8-1
Section 4. Quality assurance	III-4-(i)
<i>(To be developed)</i>	

	<i>Page</i>
Section 5. Publication	III-5-(i)
Chapter 1. Publication and charting — General.....	III-5-1-1
1.1 Introduction	III-5-1-1
1.2 Notification of differences in AIP	III-5-1-1
1.3 Departures and arrivals.....	III-5-1-1
1.4 Approach	III-5-1-2
1.5 Formal textual or tabular description of the procedure.....	III-5-1-5
1.6 Waypoint naming	III-5-1-6
1.7 Arc centre and significant point coordinates	III-5-1-7
Chapter 2. Aeronautical database publication requirements	III-5-2-1
Attachment to Part III. Derivation of the SBAS obstacle assessment surfaces (OAS)	III-Att-1
 PART IV. HELICOPTERS	 IV-(i)
Chapter 1. PBN departure procedures for helicopters using GNSS or SBAS receivers.....	IV-1-1
1.1 General	IV-1-1
1.2 Helicopter departures from instrument heliports or runways	IV-1-1
1.3 Helicopter point-in-space (PinS) departures from heliports or landing locations.....	IV-1-1
1.4 Promulgation	IV-1-5
Chapter 2. Point-in-space (PinS) RNP APCH approach procedures for helicopters down to LNAV minima	IV-2-1
2.1 General	IV-2-1
2.2 GNSS RNAV system accuracy	IV-2-1
2.3 Arrival routes.....	IV-2-1
2.4 Terminal criteria	IV-2-2
2.5 Initial approach segment.....	IV-2-2
2.6 Intermediate approach segment	IV-2-3
2.7 Final approach segment.....	IV-2-3
2.8 Missed approach segment.....	IV-2-4
2.9 PinS approach procedures with a “proceed visually” instruction.....	IV-2-5
2.10 Visual segment for PinS approach procedure with a “proceed VFR” instruction	IV-2-11
2.11 PinS approach procedure with a “proceed VFR” instruction height above surface (HAS) diagram.....	IV-2-11
2.12 Promulgation	IV-2-12
Chapter 3. Point-in-space (PinS) RNP APCH approach procedures for helicopters down to LPV minima	IV-3-1
3.1 General	IV-3-1
3.2 Final approach segment (FAS).....	IV-3-1
3.3 Visual segment: adjustment of the OCA/H and protection	IV-3-2
3.4 Supporting PinS RNP APCH with LNAV minima	IV-3-3

	<i>Page</i>
3.5 Missed approach.....	IV-3-3
3.6 Promulgation	IV-3-3
Appendix to Chapter 3. Encoding of the SBAS helicopter PinS FAS data block and display scaling	IV-3-App-1

Note.— Obstacle assessment surfaces for approach with vertical guidance and precision approach (PANS-OPS software) can be found on the ICAO public website (www.icao.int) under “Publications”.

FOREWORD

1. INTRODUCTION

1.1 The *Procedures for Air Navigation Services — Aircraft Operations* (PANS-OPS) consists of two volumes as follows:

Volume I — *Flight Procedures*

Volume II — *Construction of Visual and Instrument Flight Procedures*

The division of the PANS-OPS into the two volumes was accomplished in 1979 as a result of an extensive amendment to the obstacle clearance criteria and the construction of approach-to-land procedures (Amendments 13 and 14). Prior to 1979, all PANS-OPS material was contained in a single document. Table A shows the origin of amendments together with a list of the principal subjects involved and the dates on which the PANS-OPS and the amendments were approved by the Council and when they became applicable.

1.2 Volume I — *Flight Procedures* describes operational procedures recommended for the guidance of flight crew and flight operations personnel. It also outlines the various parameters on which the criteria in Volume II are based so as to illustrate the need to adhere strictly to the published procedures in order to achieve and maintain an acceptable level of safety in operations.

1.3 Volume II — *Construction of Visual and Instrument Flight Procedures* is intended for the guidance of procedures specialists and describes the essential areas and obstacle clearance requirements for the achievement of safe, regular instrument flight operations. It provides the basic guidelines to States, and those operators and organizations producing instrument flight charts that will result in uniform practices at all aerodromes where instrument flight procedures are carried out.

1.4 Both volumes present coverage of operational practices that are beyond the scope of Standards and Recommended Practices but with respect to which a measure of international uniformity is desirable.

1.5 The design of procedures in accordance with PANS-OPS criteria assumes normal operations. It is the responsibility of the operator to provide contingency procedures for abnormal and emergency operations.

2. COMMENTARY ON THE MATERIAL CONTAINED IN VOLUME II

2.1 Part I — General

2.1.1 This part contains the general criteria that apply to both conventional as well as RNAV and satellite-based procedures.

2.1.2 Section 1 describes the terminology to assist in the interpretation of terms which are used in the procedures and have a particular technical meaning. In some cases, the terms are defined in other ICAO documents. A list of abbreviations is also provided.

2.1.3 Section 2 provides the general criteria that apply to all phases of flight. In Amendment 12 to the 4th edition, criteria for the procedure identification were included.

2.1.4 Section 3 contains the departure procedures. The specifications concerning instrument departure procedures were first developed by the Obstacle Clearance Panel (OCP) in 1983. The material contained in Volume II was prepared for the use of the procedure design specialists and corresponding material for the use of flight operations personnel including flight crews is contained in Volume I.

2.1.5 In 1990 as a result of the work of an air navigation study group, new material was included concerning specifications, procedures and guidance material relating to the simultaneous operations on parallel or near-parallel runways, including the minimum distances between the runways.

2.1.6 Section 4 contains the general arrival and approach procedures. These procedures were first developed by the Operations Division in 1949 and issued in 1951 and have since been amended a number of times. In 1966, the Obstacle Clearance Panel (OCP) was created to update these procedures for application to all types of aeroplanes taking into account requirements for subsonic multi-jet aeroplanes and technical developments with respect to standard radio navigation aids. As a result of this work, instrument approach procedures criteria were completely revised. The new criteria were incorporated in 1979 in the First Edition of Volume II of PANS-OPS (Amendment 13).

2.2 Part II — Conventional procedures

2.2.1 This part describes the procedures for conventional navigation that are specific to the sensor.

2.2.2 Section 1 contains the criteria for precision approaches. The (ILS) precision approaches are more precise than those formerly used for non-precision approach and are based on a scientifically validated method. This has been achieved by means of:

- a) a collection of data on aircraft ILS precision approach performance measured during actual instrument meteorological conditions;
- b) the development of a mathematical model reflecting the total ILS system performance and the matching of that model against the data collected under a) above;
- c) the use of the model to extrapolate ILS precision approach performance in order to establish obstacle assessment surfaces;
- d) the development of a model of the missed approach manoeuvre based on aircraft dynamics and matched against observed data, and the use of this model to extrapolate suitable margins for use in conjunction with the approach surfaces described in c); and
- e) the combination of the ILS approach and the missed approach mathematical models into an integrated model covering the whole ILS procedure and able to provide an assessment of the risk of collision with obstacles in stated conditions.

2.2.3 A new concept of obstacle clearance for ILS has been incorporated in the new criteria in that the previously used obstacle clearance limit (OCL) concept has been replaced by the new obstacle clearance altitude/height (OCA/H) concept. Three methods of deriving OCA/H values are included which, in turn, involve progressive increases in the degree of sophistication in the treatment and accountability of obstacles. The first two methods employ the use of surfaces and the third uses a collision risk model (CRM) to derive OCA/H. The CRM is designed for use where an evaluation of the specific risk within the obstacle environment is needed to obtain the lowest obstacle clearance values compatible with the required level of safety. A computer programme has been developed for the CRM and is available for use through ICAO.

2.2.4 The precision approach criteria were expanded to MLS category I, II and III in 1994 and GBAS category I in 2004.

2.2.5 Section 2 contains the non-precision approach criteria. The obstacle clearance criteria for non-precision approaches, as amended by Amendment 13, have not been developed to the same degree of sophistication as the precision approach obstacle clearance criteria because the level of safety generally associated with the higher operating minima of non-precision approach procedures is already considered to be acceptable. The procedures, therefore, continue to be based upon available experience and the judgements of experts. They, however, were amended to provide a high degree of flexibility designed to assist the procedures specialist in obtaining the maximum operational advantage compatible with safety.

2.2.6 Based mainly on the experience gained by some States during trial application of the new criteria and as a result of the ICAO PANS-OPS workshop series held from 1980-1984, the criteria were amended twice (Amendments 1 and 4). The changes fall into three general categories as follows:

- editorial amendments to ease the understanding of the criteria
- simplification of calculations which have proved, in practice, to contain a high error potential
- removal of discrepancies which could have made the document difficult to apply and operationally penalizing.

Amendment 1 also aligned the presentation of units with Annex 5, Fourth Edition.

2.2.7 Section 3 contains the criteria for en-route operations for VOR and NDB. These criteria were added to the PANS-OPS in 1996. In 2004 simplified criteria were added to allow for less time consuming effort in large airspaces.

2.2.8 Section 4 contains the criteria for holding procedures. Holding procedures were first developed by the Operations Division in 1949 and issued in 1951. A major revision of these procedures was accomplished in 1965 as a result of the work of the Holding Procedures Panel (HOP). The material developed by the HOP was subsequently divided in 1979 and that part of the material concerning holding procedures was incorporated in PANS-OPS, Volume I and the material covering the construction of holding procedures incorporated in Volume II.

2.2.9 In 1982 as a result of the work of the Obstacle Clearance Panel (OCP) new material and changes to the old material were introduced concerning VOR/DME holding, use of holding procedures by helicopters, buffer areas and entry procedures. In 1986, changes were introduced concerning the VOR TO/FROM indication error zone, the minimum usable DME distance and holding speeds, particularly above 4 250 m (14 000 ft).

2.3 Part III — RNAV procedures and satellite based procedures

2.3.1 The first RNAV departure procedures were incorporated in PANS-OPS with the introduction of area navigation (RNAV) departure procedures based on VOR/DME in 1993 arising from the Ninth Meeting of the Obstacle Clearance Panel. Departure procedures for DME/DME, basic GNSS followed in 1998, Procedures for RNP and SBAS departure procedures were introduced in 2001 and 2004 respectively.

Arrival and approach procedures

2.3.2 Similar to the departure procedures, Area navigation (RNAV) criteria for instrument approach procedures were introduced for VOR/DME in 1993. Approach procedures for DME/DME, basic GNSS followed in 1998. Procedures for RNP 0.3 were introduced in 2001. As a result of a CFIT safety initiative, Baro-VNAV criteria based on DME/DME or basic GNSS sensors were included in the document in 2001.

2.3.3 In 2004, GLS Cat I (ILS look alike) criteria based on GBAS receivers were introduced in PANS-OPS. GLS Cat II/III criteria can be expected after the Annex 10 SARPs have been finalized.

2.3.4 The T/Y bar concept was introduced for basic GNSS in 1998 and made applicable for RNAV approach procedures in general in 2004. To facilitate pilots flying a T/Y bar approach, the Terminal Arrival Altitude (TAA) concept was also included.

Holding procedures

2.3.5 Area navigation (RNAV) criteria for holding procedures were included in 1993 arising from the ninth meeting of the Obstacle Clearance Panel. RNP holding procedures were added in 1998. In the 5th edition of PANS-OPS, as a result of the rewrite of PANS-OPS, the VOR/DME criteria were generalized to include DME/DME and basic GNSS as well.

2.4 PART IV — Helicopters

Part IV contains the criteria applicable for Helicopter Point-in-space procedures based on a basic GNSS receiver which were introduced in 2004.

3. STATUS

Procedures for Air Navigation Services (PANS) do not have the same status as Standards and Recommended Practices. While the latter are *adopted* by Council in pursuance of Article 37 of the Convention and are subject to the full procedure of Article 90, PANS are *approved* by Council and are recommended to Contracting States for worldwide application.

4. IMPLEMENTATION

The implementation of procedures is the responsibility of Contracting States; they are applied in actual operations only after, and in so far as States have enforced them. However, with a view to facilitating their processing towards implementation by States, they have been prepared in a language which will permit direct use by operations personnel. While uniform application of the basic procedures in this document is very desirable, latitude is permitted for the development of detailed procedures which may be needed to satisfy local conditions.

5. PUBLICATION OF DIFFERENCES

5.1 The PANS do not carry the status afforded to Standards adopted by the Council as Annexes to the Convention and, therefore, do not come within the obligation imposed by Article 38 of the Convention to notify differences in the event of non-implementation.

5.2 However, attention of States is drawn to the provisions of Annex 15 related to the publication in their aeronautical information publications of lists of significant differences between their procedures and the related ICAO procedures.

6. PROMULGATION OF INFORMATION

The establishment and withdrawal of and changes to facilities, services and procedures affecting aircraft operations provided in accordance with the procedures specified in this document should be notified and take effect in accordance with the provisions of Annex 15.

7. UNITS OF MEASUREMENT

Units of measurement are given in accordance with the provisions contained in Annex 5. In those cases where the use of an alternative non-SI unit is permitted, the non-SI unit is shown in brackets immediately following the primary SI unit. In all cases the value of the non-SI unit is considered to be operationally equivalent to the primary SI unit in the context in which it is applied. Unless otherwise indicated, the allowable tolerance (accuracy) is indicated by the number of significant figures given and, in this regard, it is to be understood in this document that all zero digits, either to the right or left of the decimal marker, are significant figures.

Table A. Amendments to the PANS-OPS

<i>Amendment</i>	<i>Source(s)</i>	<i>Subject(s)</i>	<i>Approved Applicable</i>
(1st Edition)	Council Action	Previous operations procedures brought together into a single document.	26 June 1961 1 October 1961
1	Internal ICAO action to resolve inconsistencies	Alignment of the definition of “Final approach” and provisions relating to intermediate and final approach procedures.	27 June 1962 1 July 1962
2	AIS/MAP Divisional Meeting (1959)	Minimum sector altitudes.	14 December 1962 1 November 1963
3	Second Meeting of Holding Procedures Panel (1964)	Updating of holding procedures.	5 April 1965 5 May 1966
4	Meteorology and Operational Divisional Meeting (1964)	Addition of meteorological information for flight operations.	7 June 1965 (advisory material)
5 (2nd Edition)	Fourth Air Navigation Conference (1965) and Amendment 8 to Annex 2	ILS Category I procedures, radar approach procedures, introduction of ILS Category II procedures, altimeter setting procedures.	12 December 1966 24 August 1967
6	Fifth Air Navigation Conference (1967), First Meeting of Obstacle Clearance Panel (1968) and Air Navigation Commission	QNH altimeter setting procedures for take-off and landing, new advisory material relating to instrument approach procedures for offset facilities and editorial changes.	23 January 1969 18 September 1969
7	Sixth Air Navigation Conference (1969)	Operating procedures for the use of secondary surveillance radar (SSR) transponders.	15 May 1970 4 February 1971
8 (3rd Edition)	Second Meeting of the Obstacle Clearance Panel (1970)	New profile diagrams and editorial changes.	19 March 1971 6 January 1972
9	Third Meeting of the Obstacle Clearance Panel (1971)	Editorial changes relating to special procedures, areas and obstacle clearances — Precision Aids — ILS with glide path inoperative.	15 November 1972 16 August 1973
10	Council action in pursuance of Assembly Resolutions A17-10 and A18-10	Practices to be followed in the event of unlawful interference.	7 December 1973 23 May 1974
11	Air Navigation Commission study	Practice to be followed in the event of unlawful interference.	12 December 1973 12 August 1976
12	Ninth Air Navigation Conference (1976)	Definitions of flight level and transition altitude, operational use of transponders, advisory material on ground exchange of operational meteorological information.	9 December 1977 10 August 1978

<i>Amendment</i>	<i>Source(s)</i>	<i>Subject(s)</i>	<i>Approved Applicable</i>
13 (Volume II, 1st Edition)	Sixth Meeting of the Obstacle Clearance Panel (1978)	Complete revision of material related to procedure construction and obstacle clearance criteria for instrument approach procedures. Editorial rearrangement of the PANS-OPS into two volumes.	29 June 1979 25 November 1982
1 (Volume II, 2nd Edition)	Seventh Meeting of the Obstacle Clearance Panel (1981)	Modification and clarification of Part III and alignment of presentation of units with Annex 5, Fourth Edition.	8 February 1982 25 November 1982
2	Seventh Meeting of the Obstacle Clearance Panel (1981); Fourth Meeting of the Operations Panel (1981)	Changes to the holding criteria, e.g. introduction of VOR/DME holding criteria and a new holding area construction method in Part IV. Introduction of new Part V for helicopter procedures.	30 March 1983 24 November 1983
3	Seventh Meeting of the Obstacle Clearance Panel (1981)	Introduction of criteria for departure procedures	25 November 1983 22 November 1984
4 (Volume II, 3rd Edition)	Recommendations developed by the Obstacle Clearance Panel through correspondence and at its eighth meeting and by the Communications/ Operations Divisional Meeting (COM/OPS/1985)	Part III. — Introduction of a provision related to earliest location of MAPt; deletion of TP defined by a distance (timing); deletion of d_z min between SOC and TP in precision missed approach; amalgamation of provisions related to the protection of holding and racetrack procedures; refinement of ILS turning missed approach criteria; introduction of MLS interim criteria for ILS-type approaches; editorial amendments. Part IV. — VOR TO/FROM indication error zone; holding speeds; deletion of word “standard” in relation to holding; editorial amendments.	7 May 1986 20 November 1986
5	Obstacle Clearance Panel, Fourth Meeting of the Helicopter Operations (HELIOPS) Panel, Air Navigation Commission	Introduction of a new Chapter 5 related to simultaneous operations on parallel or near-parallel instrument runways; introduction in Part V of a new Chapter 2 — Procedures Specified for Use by Helicopters Only; editorial amendments.	23 March 1990 15 November 1990
6 (Volume II, 4th Edition)	Ninth Meeting of the Obstacle Clearance Panel (1990), Fifth Meeting of the Operations Panel (1989) and Amendment 69 to Annex 10.	Amendment of the definitions of minimum descent altitude/height (MDA/H), obstacle clearance altitude/height (OCA/H) and minimum sector altitude and inclusion of the definitions of decision altitude/height (DA/H), area navigation (RNAV) and waypoint. Introduction in Part II of a new Chapter 7 related to area navigation (RNAV) departure procedures based on VOR/DME. Amendment to Part II concerning departure criteria to include secondary areas; clarify the application of the gradient criteria; include the concept of close-in obstacles and deletion of the acceleration segment. Amendment to Part III, Chapter 5 to include a reference to the MLS in the text of the general criteria for the intermediate approach segment. Amendment to Part III, Chapter 7 related to missed approach segment. Amendment to Part III, Chapter 9 related to minimum sector altitudes. Amendment to Part III, Chapter 24 related to the procedures based on tactical vectoring. Introduction in Part III of a new Chapter 31 related to area navigation (RNAV) approach procedures based on VOR/DME. Amendment to Part III, Attachment C related to VOR/DME entry procedures. Amendment to Part III, Attachment K	3 March 1993 11 November 1993

Amendment	Source(s)	Subject(s)	Approved Applicable
		concerning the en-route approach interface to update its contents with the RNAV related material. Amendment to Part III, Attachment M related to MLS criteria for ILS-type approaches. Introduction in Part III of a new Attachment N related to visual manoeuvring using a prescribed track. Introduction in Part IV of a new Chapter 2 related to RNAV holding procedures based on VOR/DME. Amendment of the DME fix tolerances to reflect current DME/N accuracy characteristics.	
7	Air Navigation Commission	Simultaneous operations on parallel or near-parallel instrument runways	13 March 1995 9 November 1995
8	Tenth Meeting of the Obstacle Clearance Panel (1994)	Introduction of new definitions and abbreviations in Part I, Chapter 1. Modification of the provisions concerning departure procedures in Part II, Chapter 2, and departure procedures published information in Part II, Chapter 5. Modification of the area navigation (RNAV) departure provisions based on VOR/DME in Part II, Chapter 7. Modification of and new provisions concerning criteria for standard instrument arrivals in Part III, Chapter 3. Modification of the initial approach segments using reversal procedures in Part III, Chapter 4. Modification of the intermediate approach segment in Part III, Chapter 5. Modification of the missed approach segment in Part III, Chapter 7. Modification of the ILS criteria in Part III, Chapter 21. Modification of the localizer only procedure in Part III, Chapter 22. Revision of the radar procedure in Part III, Chapter 24. Modification of the VOR procedures with final approach fix in Part III, Chapter 26. Introduction of new chapters in Part III concerning MLS Categories I, II and III (Chapter 30), azimuth only or MLS with glide path inoperative (Chapter 30A) and MLS Category I with non-standard azimuth alignment (Chapter 30B). Revision of the area navigation approach procedures in Part III, Chapter 31. Modification of the holding procedures in Part IV, Chapter 1. Modification of the area navigation (RNAV) holding procedures based on VOR/DME in Part IV, Chapter 2. Introduction in Part VI of new obstacle clearance criteria for en-route. Revision of the background information on ILS in Attachment A to Part III. Revision of the examples of OAS calculations in Attachment B to Part III. Additions and editorial amendments to protection areas of RNAV holding procedures based on VOR/DME in Attachment C to Part III. Introduction of an example of alternative area navigation (RNAV) holding entries for reduced holding entry areas in Attachment C to Part IV.	4 March 1996 7 November 1996
9	Tenth Meeting of the Obstacle Clearance Panel (1994)	Amendment to Part II, paragraph 7.4 concerning RNAV departure turns based on fly-by waypoints.	12 March 1997 6 November 1997

<i>Amendment</i>	<i>Source(s)</i>	<i>Subject(s)</i>	<i>Approved Applicable</i>
10	Eleventh Meeting of the Obstacle Clearance Panel, Amendment 51 to Annex 4 and Amendment 38 to Annex 11	<p>Introduction of new and amended definitions in Part I. Introduction of average flight path in Part II, Chapter 2. Modification of the turning departure parameters in Part II, Chapter 3. Introduction of a new Part II, Chapter 8 on area navigation (RNAV) departure procedures based on DME/DME. Introduction of new Attachment A to Part II on average flight path for departure procedures. Amendments to the standard instrument arrivals in Part III, Chapter 3. Modification of the final approach segment alignment and descent gradients in Part III and introduction of new criteria for steep angle approaches. Introduction of a new Part III, Chapter 32 on area navigation (RNAV) approach procedures based on DME/DME. Introduction of a new Part III, Chapter 33 on area navigation (RNAV) approach procedures for basic GNSS receivers. Inclusion of obstacle clearance area for RNP holdings in Attachment C to Part III. Introduction of RNAV material in Attachment K to Part III. Inclusion of new material related to the calculation of minimum length of segments limited by waypoints in Attachment M to Part III.</p> <p>Introduction of material related to approval of documentation for flight management systems in Attachment O to Part III. Introduction of formulas for the calculation of DME/DME fix tolerances and area widths in Attachment P to Part III. Introduction of material on basic GNSS receiver specifications in Attachment Q to Part III. Introduction of new material on steep angle approaches in Attachment R to Part III. Introduction of a new Part IV, Chapter 3 on RNP holding procedures. Introduction of a new Part VI, Chapter 2 on RNAV/RNP routes. Editorial amendments.</p>	<p>1 May 1998 5 November 1998</p>
11	Amendment 52 to Annex 4, Eleventh Meeting of the Obstacle Clearance Panel, Twelfth Meeting of the Obstacle Clearance Panel	<p>Introduction of new definitions and abbreviations in Part I. Introduction in Parts II and III of required navigation performance (RNP) procedures for departure, arrival and approach procedures, including criteria for fixed radius turns and basic GNSS departure and arrival procedures. Introduction in Part III of material with regard to the portrayal of terrain and minimum flight altitudes, a specification of maximum descent rate for the final approach segment for non-precision approach (NPA) procedures, barometric vertical navigation (baro-VNAV) criteria, and RNAV database path terminator concept. Amendment in Part III of basic GNSS approach procedures and DME/DME procedures to account for reversion. Deletion of Part V, Chapters 1 and 2. Integration of helicopter criteria throughout the document.</p>	<p>29 June 2001 November 2001</p>

Amendment	Source(s)	Subject(s)	Approved Applicable
12	Thirteenth meeting of the Obstacle Clearance Panel (OCP/13)	Foreword — introduction of a phrase to amplify the notion that PANS-OPS applies to normal operations; Part I — introduction of new definitions and abbreviations; Part II — introduction of altitude depiction requirements, provisions to procedure identification on charts, improvements in the size of the area width of the obstacle protection area for distance measuring equipment DME/DME and required navigation performance (RNP) procedures, introduction of SBAS procedures; Part III — introduction of altitude depiction requirements, provisions to procedure identification on charts, amendment to the basis of categorization of aircraft, introduction of the procedure altitude concept to address CFIT, the T/Y bar approach layout for RNAV procedures, the TAA concept, amendment to the standard aircraft dimensions for determination of DA/H, improvements in the size of the area width of the obstacle protection area for distance measuring equipment DME/DME and required navigation performance (RNP) procedures, a complete revision of APV/Baro-VNAV criteria, introduction of GBAS Category I criteria, replacement of Attachment I with a PANS-OPS obstacle assessment surface (OAS0 CD-ROM; Part V — introduction of RNAV point-in-space (PinS) approach procedures for helicopters using basic GNSS receivers; Part VI — amendment to en-route criteria to include a simplified method.	27 April 2004 25 November 2004
13 (Volume II, 5th Edition)	Eleventh meeting of the Obstacle Clearance Panel (OCP/11)	Editorial amendment to provide a more logical layout and improve the consistency and clarity of the document in order to: a) facilitate correct implementation; and b) provide a better framework for future development.	2 October 2006 23 November 2006
1	Fourteenth meeting of the Obstacle Clearance Panel (OCP/14)	a) new provisions for units of measurement; b) new approach procedures with vertical guidance (APV) for satellite-based augmentation system (SBAS) operations; c) vertical navigation (VNAV) operations; d) new provisions for quality assurance in the procedure design process; e) new provisions for basic global navigation satellite system (GNSS); f) consolidation of turn protection criteria; and g) enhancement of existing procedures related to the visual segment surface.	30 November 2006 15 March 2007

Amendment	Source(s)	Subject(s)	Approved Applicable
2	First working group of the whole meeting of the Instrument Flight Procedures Panel (IFPP/WG/WHL/1)	<ul style="list-style-type: none"> a) alignment of the procedure design criteria for area navigation (RNAV) applications with the performance-based navigation (PBN) concept; b) expansion of the guidance on coding requirements for satellite-based augmentation system (SBAS) and ground-based augmentation system (GBAS) final approach segment (FAS) data block and extension of the existing precision approach criteria for simultaneous approaches to parallel or near parallel runways and for procedures with glide paths above 3.5° to approach with vertical guidance (APV) SBAS procedures; c) modification of the procedure design criteria to allow SBAS certified aircraft to fly Baro-VNAV procedures without having to change the chart; d) new criteria to help to prevent Controlled Flight Into Terrain (CFIT) during helicopter operations in visual flight rules (VFR) conditions; e) explanation of the validity of the target level of safety for the Collision Risk Model (CRM) to amplify the differences between the CRM and the obstacle assessment surface (OAS) method, also restricting it to the final approach segment; f) validation of the instrument flight procedures which is a critical element of the flight procedure design process; g) addition of a reference to the new <i>Quality Assurance Manual for Flight Procedure Design</i> (Doc 9906) and additional training requirements to ensure that the quality assurance in the procedure design process and its output meets the requirements of Annex 15; h) addition of a reference to the new <i>Required Navigation Performance Authorization Required (RNP AR) Procedure Design Manual</i> (Doc 9905); and i) addition of a note on how to handle precision approaches with regard to new larger aircraft from a procedure design perspective; includes additional information on waypoints on straight segments to increase the efficiency of air traffic; adds criteria for procedure designers and pilots on manual RNAV holding; deletes the requirement of increased minimum obstacle clearance (MOC) for final approaches longer than 11 km (6 NM); and relaxes the requirement to apply the terminal arrival altitude concept instead of the minimum sector altitude (MSA). 	8 October 2008 20 November 2008

<i>Amendment</i>	<i>Source(s)</i>	<i>Subject(s)</i>	<i>Approved Applicable</i>
3	Second and third working group of the whole meetings of the Instrument Flight Procedures Panel (IFPP/WG/WHL/2 and 3)	<ul style="list-style-type: none"> a) Introduction of the definition of GBAS landing system (GLS); b) a new provision to emphasize that the ILS criteria cannot be used for assessing the effect on safety of penetrations of the Annex 14 — <i>Aerodromes</i> obstacle limitation surfaces; c) modifications to the provisions regarding design criteria to address navigation database coding problems of instrument flight procedures that are published in State aeronautical information publications (AIPs); and d) refinement of procedure design quality assurance aspects with emphasis on flight validation. 	23 July 2010 18 November 2010
4	Fifth and sixth working group of the whole meetings of the Instrument Flight Procedures Panel (IFPP/WG/WHL/5 and 6)	<ul style="list-style-type: none"> a) charting aspects of PBN (area navigation (RNAV) and required navigation performance (RNP)) procedures, with emphasis on RF legs; b) the responsibility of the State in identifying the appropriate satellite-based augmentation system (SBAS) provider for the procedure; c) the definition of terminology to avoid misunderstanding on data transfer between the procedure designer and the database coder; and d) clarification of SBAS vertical guidance on procedures designed for barometric vertical navigation (baro-VNAV) and for vertically guided procedures down to localizer performance with vertical guidance (LPV) minima. 	1 September 2011 17 November 2011
5	Secretariat supported by the Approach Classification Task Force (ACTF) in coordination with the Aerodromes Panel (AP), the Instrument Flight Procedure Panel (IFPP), the Navigation Systems Panel (NSP) and the Operations Panel (OPSP)	Amendment concerning provisions related to instrument approach operations and procedures as a result of the new approach classification.	20 March 2013 13 November 2014
6 (Volume II, 6th Edition)	Seventh, eighth, ninth, tenth and eleventh meetings of the Instrument Flight Procedures Panel Working Group of the Whole (IFPP/WG/WHL/7, 8, 9, 10 and 11)	Amendment concerning procedure design criteria and charting requirements to support performance-based navigation (PBN) as well as helicopter point-in space (PinS) approach and departure operations	23 April 2014 13 November 2014
7	The twelfth meeting of the Instrument Flight Procedures Panel (IFPP/12)	Provisions concerning MOC reduction for turning departure procedures, the use of CF on departure legs, Baro-VNAV offset procedures, the use of PBN with ILS/MLS/GLS, SBAS and GBAS procedure design requirements, VSS penetrations requirements, AMA determination requirements.	26 May 2016 10 November 2016

**Procedures for
Air Navigation Services**

AIRCRAFT OPERATIONS

Part I

GENERAL

Section 1

**DEFINITIONS, ABBREVIATIONS AND ACRONYMS
AND UNITS OF MEASUREMENT**

Chapter 1

DEFINITIONS

When the following terms are used in this document, they have the following meanings:

Aerodrome elevation. The elevation of the highest point of the landing area.

Along-track tolerance (ATT). A fix tolerance along the nominal track resulting from the airborne and ground equipment tolerances.

Altitude. The vertical distance of a level, a point or an object considered as a point, measured from mean sea level (MSL).

Area minimum altitude (AMA). The minimum altitude to be used under instrument meteorological conditions (IMC), that provides a minimum obstacle clearance within a specified area, normally formed by parallels and meridians.

Area navigation (RNAV). A method of navigation which permits aircraft operation on any desired flight path within the coverage of the station-referenced navigation aids or within the limits of the capability of self-contained aids, or a combination of these.

Base turn. A turn executed by the aircraft during the initial approach between the end of the outbound track and the beginning of the intermediate or final approach track. The tracks are not reciprocal.

Note.— Base turns may be designated as being made either in level flight or while descending, according to the circumstances of each individual procedure.

Change-over point. The point at which an aircraft navigating on an ATS route segment defined by reference to very high frequency omnidirectional radio ranges is expected to transfer its primary navigational reference from the facility behind the aircraft to the next facility ahead of the aircraft.

Note.— Change-over points are established to provide the optimum balance in respect of signal strength and quality between facilities at all levels to be used and to ensure a common source of azimuth guidance for all aircraft operating along the same portion of a route segment.

Circling approach. An extension of an instrument approach procedure which provides for visual circling of the aerodrome prior to landing.

Continuous climb operation (CCO). An operation, enabled by airspace design, procedure design and ATC, in which a departing aircraft climbs continuously, to the greatest possible extent, by employing optimum climb engine thrust and climb speeds until reaching the cruise flight level.

Continuous descent final approach (CDFA). A technique, consistent with stabilized approach procedures, for flying the final approach segment of a non-precision instrument approach procedure as a continuous descent, without level-off, from an altitude/height at or above the final approach fix altitude/height to a point approximately 15 m (50 ft) above the landing runway threshold or the point where the flare manoeuvre should begin for the type of aircraft flown.

Continuous descent operation (CDO). An operation, enabled by airspace design, procedure design and ATC, in which an arriving aircraft descends continuously, to the greatest possible extent, by employing minimum engine thrust, ideally in a low drag configuration, prior to the final approach fix /final approach point.

Contour line. A line on a map or chart connecting points of equal elevation.

Course. The intended direction of travel of an aircraft, expressed in degrees from North (true, magnetic or grid).

Cross-track tolerance (XTT). A fix tolerance measured perpendicularly to the nominal track resulting from the airborne and ground equipment tolerances and the flight technical tolerance (FTT).

Cyclic redundancy check (CRC). A mathematical algorithm applied to the digital expression of data that provides a level of assurance against loss or alteration of data.

Datum crossing point (DCP). The DCP is a point on the glide path directly above the LTP or FTP at a height specified by the RDH.

Dead reckoning (DR) navigation. The estimating or determining of position by advancing an earlier known position by the application of direction, time and speed data.

Decision altitude (DA) or decision height (DH). A specified altitude or height in a 3D instrument approach operation at which a missed approach must be initiated if the required visual reference to continue the approach has not been established.

Note 1.— Decision altitude (DA) is referenced to mean sea level and decision height (DH) is referenced to the threshold elevation.

Note 2.— The required visual reference means that section of the visual aids or of the approach area which should have been in view for sufficient time for the pilot to have made an assessment of the aircraft position and rate of change of position, in relation to the desired flight path. In Category III operations with a decision height the required visual reference is that specified for the particular procedure and operation.

Note 3.— For convenience where both expressions are used they may be written in the form “decision altitude/height” and abbreviated “DA/H”.

Dependent parallel approaches. Simultaneous approaches to parallel or near-parallel instrument runways where radar separation minima between aircraft on adjacent extended runway centre lines are prescribed.

Descent fix. A fix established in a precision approach at the FAP to eliminate certain obstacles before the FAP, which would otherwise have to be considered for obstacle clearance purposes.

Descent point (DP). A point defined by track and distance from the MAPt to identify the point at which the helicopter may descend below the OCA/H on a visual descent to the heliport/landing location.

Direct visual segment (Direct-VS). A visual segment designed as:

- a) a leg in a PinS approach, which may contain a single turn, from the MAPt direct to the heliport or landing location or via a descent point to the heliport or landing location; or
- b) a straight leg from the heliport or landing location to the IDF in a PinS departure.

DME distance. The line of sight distance (slant range) from the source of a DME signal to the receiving antenna.

Elevation. The vertical distance of a point or a level, on or affixed to the surface of the earth, measured from mean sea level.

European GNSS navigation overlay service (EGNOS). A satellite-based augmentation system providing navigation service meeting Annex 10 requirements that provides navigation service in the European Region.

Fictitious heliport point (FHP). The FHP is a point over which the PinS final approach segment path passes at a relative height defined as the fictitious heliport point crossing height (FHPCH). It is defined by the WGS-84 latitude, longitude and ellipsoid height. The FHP replaces the FTP for PinS approaches. The FHP elevation is the same as the actual landing heliport elevation.

Fictitious threshold point (FTP). The FTP is a point over which the final approach segment path passes at a relative height specified by the reference datum height. It is defined by the WGS-84 latitude, longitude and ellipsoid height. The FTP replaces the LTP when the final approach course is not aligned with the runway extended centre line or when the threshold is displaced from the actual runway threshold. For non-aligned approaches the FTP lies on the intersection of the perpendicular from the FAS to the runway threshold. The FTP elevation is the same as the actual runway threshold elevation.

Final approach and take-off area (FATO). A defined area over which the final phase of the approach manoeuvre to hover or landing is completed and from which the take-off manoeuvre is commenced. Where the FATO is to be used by performance Class 1 helicopters, the defined area includes the rejected take-off area available.

Final approach segment. That segment of an instrument approach procedure in which alignment and descent for landing are accomplished.

Final approach segment (FAS) data block. The set of parameters to identify a single precision approach or APV and define its associated approach path.

Final approach track. The flight track in the final approach segment that is normally aligned with the runway centre line. For offset final approach segments, the final approach track is aligned with the orientation of the FTP and the FPAP.

Flight level (FL). A surface of constant atmospheric pressure which is related to a specific pressure datum, 1 013.2 hectopascals (hPa), and is separated from other such surfaces by specific pressure intervals.

Note 1.— A pressure type altimeter calibrated in accordance with the Standard Atmosphere:

- a) when set to a QNH altimeter setting, will indicate altitude;*
- b) when set to a QFE altimeter setting, will indicate height above the QFE reference datum;*
- c) when set to a pressure of 1 013.2 hPa, may be used to indicate flight levels.*

Note 2.— The terms “height” and “altitude”, used in Note 1 above, indicate altimetric rather than geometric heights and altitudes.

Flight path alignment point (FPAP). The FPAP is a point in the same lateral plane as the LTP or FTP that is used to define the alignment of the final approach segment. For approaches aligned with the runway centre line, the FPAP is located at or beyond the opposite threshold of the runway. The delta length offset from the opposite threshold of the runway defines its location.

Flight procedure designer. A person responsible for flight procedure design who meets the competency requirements as laid down by the State.

Full-scale deflection (FSD). The term used to describe the maximum deviation from center of either a course deviation indicator (CDI) or a vertical deviation indicator (VDI), such as a glide slope indicator, and that applies to both linear and angular scaling.

GBAS azimuth reference point (GARP). The GARP is defined to be beyond the FPAP along the procedure centre line by a fixed offset of 305 m (1 000 ft). It is used to establish the lateral deviation display limits.

GBAS landing system (GLS). A system for approach and landing operations utilizing GNSS, augmented by a ground-based augmentation system (GBAS), as the primary navigational reference.

Geoid. The equipotential surface in the gravity field of the Earth, which coincides with the undisturbed mean sea level (MSL) extended continuously through the continents.

Note.— The geoid is irregular in shape because of local gravitational disturbances (wind tides, salinity, current, etc.) and the direction of gravity is perpendicular to the geoid at every point.

Geoid undulation. The distance of the geoid above (positive) or below (negative) the mathematical reference ellipsoid.

Note.— In respect to the World Geodetic System — 1984 (WGS-84) defined ellipsoid, the difference between the WGS-84 ellipsoidal height and orthometric height represents WGS-84 geoid undulation.

Global navigation satellite system (GNSS). A worldwide position and time determination system that includes one or more satellite constellations, aircraft receivers and system integrity monitoring, augmented as necessary to support the required navigation performance for the intended operation.

Note.— GNSS performance standards are found in Annex 10, Volume I, Chapter 3.

Ground-based augmentation system (GBAS). An augmentation system in which the user receives augmentation information directly from a ground-based transmitter.

Heading. The direction in which the longitudinal axis of an aircraft is pointed, usually expressed in degrees from North (true, magnetic, compass or grid).

Height. The vertical distance of a level, a point or an object considered as a point, measured from a specified datum.

Height above surface (HAS). The difference in height between the OCA and the elevation of the highest terrain, water surface or obstacle within a radius of at least 1.5 km (0.8 NM) from the MAPt in a PinS “Proceed VFR” procedure.

Heliport reference point (HRP). The designated location of the heliport or landing location.

Holding fix. A geographical location that serves as a reference for a holding procedure.

Holding procedure. A predetermined manoeuvre which keeps an aircraft within a specified airspace while awaiting further clearance.

Independent parallel approaches. Simultaneous approaches to parallel or near-parallel instrument runways where radar separation minima between aircraft on adjacent extended runway centre lines are not prescribed.

Independent parallel departures. Simultaneous departures from parallel or near-parallel instrument runways.

Initial approach fix (IAF). A fix that marks the beginning of the initial segment and the end of the arrival segment, if applicable.

Initial approach segment. That segment of an instrument approach procedure between the initial approach fix and the intermediate approach fix or, where applicable, the final approach fix or point.

Initial departure fix (IDF). The terminal fix for the visual segment and the fix where the instrument phase of the PinS departure begins.

Instrument approach operations. An approach and landing using instruments for navigation guidance based on an instrument approach procedure. There are two methods for executing instrument approach operations:

- a) a two-dimensional (2D) instrument approach operation, using lateral navigation guidance only; and
- b) a three-dimensional (3D) instrument approach operation, using both lateral and vertical navigation guidance.

Note.— Lateral and vertical navigation guidance refers to the guidance provided either by:

- a) a ground-based radio navigation aid; or
- b) computer-generated navigation data from ground-based, space-based, self-contained navigation aids or a combination of these.

Instrument approach procedure (IAP). A series of predetermined manoeuvres by reference to flight instruments with specified protection from obstacles from the initial approach fix, or where applicable, from the beginning of a defined arrival route to a point from which a landing can be completed and thereafter, if a landing is not completed, to a position at which holding or en-route obstacle clearance criteria apply. Instrument approach procedures are classified as follows:

Non-precision approach (NPA) procedure. An instrument approach procedure designed for 2D instrument approach operations Type A.

Note.— Non-precision approach procedures may be flown using a continuous descent final approach (CDFA) technique. CDFAs with advisory VNAV guidance calculated by on-board equipment (see Part I, Section 4, Chapter 1, paragraph 1.8.1) are considered 3D instrument approach operations. CDFAs with manual calculation of the required rate of descent are considered 2D instrument approach operations. For more information on CDFAs, refer to Part I, Section 4, Chapter 1, paragraphs 1.7 and 1.8.

Approach procedure with vertical guidance (APV). A performance-based navigation (PBN) instrument approach procedure designed for 3D instrument approach operations Type A.

Precision approach (PA) procedure. An instrument approach procedure based on navigation systems (ILS, MLS, GLS and SBAS Cat I) designed for 3D instrument approach operations Type A or B.

Note.— Refer to Annex 6 for instrument approach operation types.

Intermediate approach segment. That segment of an instrument approach procedure between either the intermediate approach fix and the final approach fix or point, or between the end of a reversal, racetrack or dead reckoning track procedure and the final approach fix or point, as appropriate.

Intermediate fix (IF). A fix that marks the end of an initial segment and the beginning of the intermediate segment.

Landing location. A marked or unmarked area that has the same physical characteristics as a visual heliport final approach and take-off area (FATO).

Landing threshold point (LTP). The LTP is a point over which the glide path passes at a relative height specified by the reference datum height. It is defined by the WGS-84 latitude, longitude and ellipsoid height. The LTP is normally located at the intersection of the runway centre line and threshold.

Level. A generic term relating to the vertical position of an aircraft in flight and meaning variously, height, altitude or flight level.

Localizer performance (LP). The label to denote minima lines associated with the lateral element of APV-1 performance on approach charts.

Localizer performance with vertical guidance (LPV). The label to denote minima lines associated with APV-I or APV-II performance on approach charts.

Manoeuvring visual segment (Manoeuvring-VS). PinS visual segment protected for the following manoeuvres for:

- a) *PinS approaches.* Visual manoeuvre from the MAPt around the heliport or landing location to land from a direction other than directly from the MAPt.
- b) *PinS departures.* Take-off in a direction other than directly to the IDF followed by visual manoeuvre to join the instrument segment at the IDF.

Minimum descent altitude (MDA) or minimum descent height (MDH). A specified altitude or height in a 2D instrument approach operation or circling approach operation below which descent must not be made without the required visual reference.

Note 1.— Minimum descent altitude (MDA) is referenced to mean sea level and minimum descent height (MDH) is referenced to the aerodrome elevation or to the threshold elevation if that is more than 2 m (7 ft) below the aerodrome elevation. A minimum descent height for a circling approach is referenced to the aerodrome elevation.

Note 2.— The required visual reference means that section of the visual aids or of the approach area which should have been in view for sufficient time for the pilot to have made an assessment of the aircraft position and rate of change of position, in relation to the desired flight path. In the case of a circling approach the required visual reference is the runway environment.

Note 3.— For convenience when both expressions are used they may be written in the form “minimum descent altitude/height” and abbreviated “MDA/H”.

Minimum en-route altitude (MEA). The altitude for an en-route segment that provides adequate reception of relevant navigation facilities and ATS communications, complies with the airspace structure and provides the required obstacle clearance.

Minimum instrument meteorological conditions airspeed (V_{mini}). The minimum indicated airspeed at which a specific helicopter is certified to operate in instrument meteorological conditions.

Minimum obstacle clearance altitude (MOCA). The minimum altitude for a defined segment that provides the required obstacle clearance.

Minimum sector altitude (MSA). The lowest altitude which may be used which will provide a minimum clearance of 300 m (1 000 ft) above all objects located in an area contained within a sector of a circle of 46 km (25 NM) radius centred on a significant point, the aerodrome reference point (ARP) or the heliport reference point (HRP).

Minimum stabilization distance (MSD). The minimum distance to complete a turn manoeuvre and after which a new manoeuvre can be initiated. The minimum stabilization distance is used to compute the minimum distance between waypoints.

Missed approach holding fix (MAHF). A fix used in RNAV applications that marks the end of the missed approach segment and the centre point for the missed approach holding.

Missed approach point (MAPt). That point in an instrument approach procedure at or before which the prescribed missed approach procedure must be initiated in order to ensure that the minimum obstacle clearance is not infringed.

Missed approach procedure. The procedure to be followed if the approach cannot be continued.

Missed approach turning fix (MATF). A fix different from MAPt that marks a turn in the missed approach segment.

Mountainous area. An area of changing terrain profile where the changes of terrain elevation exceed 900 m (3 000 ft) within a distance of 18.5 km (10.0 NM).

Multi-functional transport satellite-based augmentation system (MSAS). A satellite-based augmentation system providing navigation service meeting Annex 10 requirements that provides navigation service in the Asia-Pacific Region.

Near-parallel runways. Non-intersecting runways whose extended centre lines have an angle of convergence/divergence of 15 degrees or less.111.

No transgression zone (NTZ). In the context of independent parallel approaches, a corridor of airspace of defined dimensions located centrally between the two extended runway centre lines, where a penetration by an aircraft requires a controller intervention to manoeuvre any threatened aircraft on the adjacent approach.

Obstacle assessment surface (OAS). A defined surface intended for the purpose of determining those obstacles to be considered in the calculation of obstacle clearance altitude/height for a specific APV or precision approach procedure.

Obstacle clearance altitude (OCA) or obstacle clearance height (OCH). The lowest altitude or the lowest height above the elevation of the relevant runway threshold or the aerodrome elevation as applicable, used in establishing compliance with appropriate obstacle clearance criteria.

Note 1.— Obstacle clearance altitude is referenced to mean sea level and obstacle clearance height is referenced to the threshold elevation or in the case of non-precision approach procedures to the aerodrome elevation or the threshold elevation if that is more than 2 m (7 ft) below the aerodrome elevation. An obstacle clearance height for a circling approach operation is referenced to the aerodrome elevation.

Note 2.— For convenience when both expressions are used they may be written in the form “obstacle clearance altitude/height” and abbreviated “OCA/H”.

Note 3.— See Part I, Section 4, Chapter 5, 5.4 for specific applications of this definition.

Obstacle free zone (OFZ). The airspace above the inner approach surface, inner transitional surfaces, and balked landing surface and that portion of the strip bounded by these surfaces, which is not penetrated by any fixed obstacle other than a low-mass and frangibly mounted one required for air navigation purposes.

Path and Terminator (“Path Terminator”). A two-letter code, which defines a specific type of flight path along a segment of a procedure and a specific type of termination of that flight path. Path terminators are assigned to all RNAV, SID, STAR and approach procedure segments in an airborne navigation database.

Note.— Path terminators as defined in PANS-OPS are, with the exception of the RF path terminator, established in accordance with the rules set forth in ARINC Specification 424-15, Navigation System Data Base. The rules applicable to the RF path terminator are based upon ARINC 424-17.

Point-in-space (PinS) approach. An approach procedure designed for helicopters only that includes both a visual and an instrument segment.

Point-in-space (PinS) departure. A departure procedure designed for helicopters only that includes both a visual and an instrument segment.

Point-in-space (PinS) visual segment. The segment of a helicopter PinS procedure between a point (MAPt or IDF) and the heliport or the landing location.

Point-in-space reference point (PRP). Reference point for the point-in-space approach as identified by the latitude and longitude of the MAPt.

Primary area. A defined area symmetrically disposed about the nominal flight track in which full obstacle clearance is provided. (See also *Secondary area*.)

Procedure altitude/height. A specified altitude/height flown operationally at or above the minimum altitude/height and established to accommodate a stabilized descent at a prescribed descent gradient/angle in the intermediate/final approach segment.

Procedure turn. A manoeuvre in which a turn is made away from a designated track followed by a turn in the opposite direction to permit the aircraft to intercept and proceed along the reciprocal of the designated track.

Note 1.— Procedure turns are designated “left” or “right” according to the direction of the initial turn.

Note 2.— Procedure turns may be designated as being made either in level flight or while descending, according to the circumstances of each individual procedure.

Racetrack procedure. A procedure designed to enable the aircraft to reduce altitude during the initial approach segment and/or establish the aircraft inbound when the entry into a reversal procedure is not practical.

Reference datum height (RDH). The height of the extended glide path or a nominal vertical path at the runway threshold.

Required navigation performance (RNP). A statement of the navigation performance necessary for operation within a defined airspace.

Note.— Navigation performance and requirements are defined for a particular RNP type and/or application.

Reversal procedure. A procedure designed to enable aircraft to reverse direction during the initial approach segment of an instrument approach procedure. The sequence may include procedure turns or base turns.

Satellite-based augmentation system (SBAS). A wide coverage augmentation system in which the user receives augmentation information from a satellite-based transmitter.

Note.— SBAS performance standards are found in Annex 10, Volume I, Chapter 3.

Secondary area. A defined area on each side of the primary area located along the nominal flight track in which decreasing obstacle clearance is provided. (See also *Primary area*.)

Segregated parallel operations. Simultaneous operations on parallel or near-parallel instrument runways in which one runway is used exclusively for approaches and the other runway is used exclusively for departures.

Significant obstacle. Any natural terrain feature or man-made fixed object, permanent or temporary, which has vertical significance in relation to adjacent and surrounding features and which is considered a potential hazard to the safe passage of aircraft in the type of operation for which the individual procedure is designed.

Note.— The term “significant obstacle” is used in this document solely for the purpose of specifying the objects considered in calculations of relevant elements of the procedure and intended to be presented on an appropriate chart series.

Significant point. A specified geographical location used in defining an ATS route or the flight path of an aircraft and for other navigation and ATS purposes.

Note.— There are three categories of significant points: ground-based navigation aid, intersection and waypoint. In the context of this definition, intersection is a significant point expressed as radials, bearings and/or distances from ground-based navigation aids.

Standard instrument arrival (STAR). A designated instrument flight rule (IFR) arrival route linking a significant point, normally on an ATS route, with a point from which a published instrument approach procedure can be commenced.

Standard instrument departure (SID). A designated instrument flight rule (IFR) departure route linking the aerodrome or a specified runway of the aerodrome with a specified significant point, normally on a designated ATS route, at which the en-route phase of a flight commences.

Station declination. The angle between the 360°R of the VOR and true north.

Take-off run available (TORA). The length of runway declared available and suitable for the ground run of an aeroplane taking off.

Terminal arrival altitude (TAA). The lowest altitude that will provide a minimum clearance of 300 m (1 000 ft) above all objects located in an arc of a circle defined by a 46 km (25 NM) radius centred on the initial approach fix (IAF), or where there is no IAF on the intermediate approach fix (IF), delimited by straight lines joining the extremity of the arc to the IF. The combined TAAs associated with an approach procedure shall account for an area of 360 degrees around the IF.

Threshold (THR). The beginning of that portion of the runway usable for landing.

Track. The projection on the earth’s surface of the path of an aircraft, the direction of which path at any point is usually expressed in degrees from North (true, magnetic or grid).

Vertical path angle (VPA). Angle of the published final approach descent in Baro-VNAV procedures.

Visual manoeuvring (circling) area. The area in which obstacle clearance should be taken into consideration for aircraft carrying out a circling approach.

Visual segment descent angle (VSDA). The angle between the MDA/H at the MAPt/DP and the heliport crossing height.

Visual segment design gradient (VSDG). The gradient of the visual segment in a PinS departure procedure. The visual segment connects the heliport or landing location with the initial departure fix (IDF) minimum crossing altitude (MCA).

Waypoint. A specified geographical location used to define an area navigation route or the flight path of an aircraft employing area navigation. Waypoints are identified as either:

Fly-by waypoint. A waypoint which requires turn anticipation to allow tangential interception of the next segment of a route or procedure; or

Flyover waypoint. A waypoint at which a turn is initiated in order to join the next segment of a route or procedure.

Waypoint distance (WD). Distance on the WGS84 ellipsoid from a defined waypoint to the aircraft RNAV receiver.

Chapter 2

ABBREVIATIONS AND ACRONYMS

(used in this document)

AC	Advisory circular
AIP	Aeronautical information publication
AMA	Area minimum altitude
AMSL	Above mean sea level
ANP	Actual navigation performance
AOB	Angle of bank
APV	Approach procedures with vertical guidance
ARP	Aerodrome reference point
ATC	Air traffic control
ATM	Air traffic management
ATS	Air traffic services
ATT	Along-track tolerance
AZM	Azimuth
BV	Buffer value
CA	Course to an altitude
CAT	Category
CCO	Continuous climb operation
CDFA	Continuous descent final approach
CDI	Course deviation indicator
CDO	Continuous descent operation
CF	Course to a fix
C/L	Centre line
COP	Change-over point
CRC	Cyclic redundancy check
CRM	Collision risk model
DA/H	Decision altitude/height
DCP	Datum crossing point
DER	Departure end of the runway
DF	Direction finding
Direct-VS	Direct visual segment
DME	Distance measuring equipment
DP	Descent point
DR	Dead reckoning
DTT	System use accuracy
EDA	Elevation differential area
EUROCAE	European Organization for Civil Aviation Equipment
FA	Course from a fix to an altitude
FAF	Final approach fix
FAP	Final approach point
FAS	Final approach segment
FAT	Final approach track
FATO	Final approach and take-off area

FHP	Fictitious heliport point
FHPCH	Fictitious heliport point crossing height
FL	Flight level
FM	Course from a fix to manual termination
FMC	Flight management computer
FMS	Flight management system
FPAP	Flight path alignment point
FROP	Final approach roll-out point
FTE	Flight technical error
FTP	Fictitious threshold point
FTT	Flight technical tolerance
GARP	GBAS azimuth reference point
GBAS	Ground-based augmentation system
GLS	GBAS landing system
GNSS	Global navigation satellite system
GP	Glide path
GPA	Glide path angle
GPWS	Ground proximity warning system
HA	Holding/racetack to an altitude
HAE	Height above ellipsoid
HAL	Horizontal alarm limit
HCH	Heliport crossing height
HF	Holding/racetack to a fix
HL	Height loss
HM	Holding/racetack to a manual termination
HP	Helipoint
HRP	Helipoint reference point
IAC	Instrument Approach Chart
IAF	Initial approach fix
IAP	Instrument approach procedure
IAS	Indicated airspeed
IDF	Initial departure fix
IF	Intermediate approach fix
IFP	Instrument flight procedure
IFR	Instrument flight rules
ILS	Instrument landing system
IMAL	Integrity monitor alarm
IMC	Instrument meteorological conditions
ISA	International standard atmosphere
KIAS	Knots indicated airspeed
LDAH	Landing distance available — helicopters
LF	Low frequency
LOC	Localizer
LORAN	Long range air navigation system
LP	Localizer performance
LPV	Localizer performance with vertical guidance
LTP	Landing threshold point
MA/H	Minimum altitude/height
MAHF	Missed approach holding fix
Manoeuvring-VS	Manoeuvring visual segment
MAPt	Missed approach point
MATF	Missed approach turning fix
MCA	Minimum crossing altitude

MCH	Minimum crossing height
MDA/H	Minimum descent altitude/height
MEA	Minimum en-route altitude
MLS	Microwave landing system
MM	Middle marker
MOC	Minimum obstacle clearance
MOCA	Minimum obstacle clearance altitude
MSA	Minimum sector altitude
MSD	Minimum stabilization distance
MSL	Mean sea level
NDB	Non-directional beacon
NM	Nautical mile
NPA	Non-precision approach
NSE	Navigational system error
NTZ	No transgression zone
OAS	Obstacle assessment surface
OCA/H	Obstacle clearance altitude/height
OCA/H _{fm}	OCA/H for the final approach and straight missed approach
OCA/H _{ps}	OCA/H for the precision segment
OCS	Obstacle clearance surface
OFZ	Obstacle free zone
OIS	Obstacle identification surface
OJT	On-the-job training
OLS	Obstacle limitation surface
OM	Outer marker
PA	Precision approach
PAPI	Precision approach path indicator
PAR	Precision approach radar
PBN	Performance-based navigation
PDG	Procedure design gradient
PinS	Point-in-space
PRP	Point-in-space reference point
R	Rate of turn
RAIM	Receiver autonomous integrity monitoring
RASS	Remote altimeter setting source
RDH	Reference datum height (for APV and PA)
RF	Constant radius arc to a fix
RNAV	Area navigation
RNP	Required navigation performance
RPDS	Reference path data selector
RSR	En-route surveillance radar
RSS	Root sum square
SA	Safety area
SARPs	Standards and Recommended Practices (ICAO)
SBAS	Satellite-based augmentation system
SD	Standard deviation
SDF	Stepdown fix
SI	International system of units
SID	Standard instrument departure
SIS	Signal in space
SOC	Start of climb
SST	Supersonic transport
ST	System computation tolerance

STAR	Standard instrument arrival
TAA	Terminal arrival altitude
TACAN	UHF tactical air navigation aid
TA/H	Turn at an altitude/height
TAR	Terminal area surveillance radar
TAS	True airspeed
TCH	Threshold crossing height
TF	Track to a fix
THR	Threshold
TMA	Terminal control area
TNA/H	Turn altitude/height
TP	Turning point
TSE	Total system error
TTT	Template tracing technique
V _{mini}	Minimum instrument meteorological conditions indicated airspeed
VA	Heading to an altitude
VAL	Vertical alarm limit
VASIS	Visual approach slope indicator system
VDF	Very high frequency direction-finding station
VEB	Vertical error budget
VHF	Very high frequency
VI	Heading to an intercept
VM	Heading to a manual termination
VOR	Very high frequency omnidirectional radio range
VPA	Vertical path angle
VS	Visual segment
VSDA	Visual segment descent angle
VSDG	Visual segment design gradient
VSS	Visual segment surface
WD	Waypoint distance
WGS	World geodetic system
XTT	Cross-track tolerance
5LNC	Five-letter name code

Chapter 3

UNITS OF MEASUREMENT

3.1 Units of measurement are expressed in conformance with Annex 5.

3.2 The values of the parameters are usually shown in integers. Where this does not provide the required accuracy, the parameter is shown with the required number of decimal places. Where the parameter directly affects the flight crew in its control of the aircraft, it is normally rounded as a multiple of five. In addition, slope gradients are normally expressed in percentages. For slope gradients expressed in other units, see *Instrument Flight Procedures Construction Manual* (Doc 9368).

3.3 In order to ensure the required accuracy when using the parameters specified in this document, only the final results of computations should be rounded. Intermediate calculations should use the maximum resolution available.

3.4 Dimensions of areas related to ILS or MLS or GBAS/SBAS, when converted to non-SI units, should be rounded up to the integer foot.

3.5 The rounding of values to be published on aeronautical charts shall meet the corresponding chart resolution requirements in Annex 4, Appendix 6.

Chapter 4

FRAME OF REFERENCE

4.1 Annex 4 — *Aeronautical Charts*, Annex 11 — *Air Traffic Services* and Annex 15 — *Aeronautical Information Services* require that WGS-84 is used as the horizontal (geodetic) reference system for international air navigation. The publication of waypoints and routes and the survey of terrain and obstacle data in WGS-84 does not mean that all airspace and procedure design calculations must be ellipsoidal. Historically, Annex 14 and PANS-OPS, Volume II, obstacle limitation and clearance areas have been defined using planar methods, and these methods continue to be acceptable. The essential requirement is that the waypoints are correctly converted to and from WGS-84, as specified in Annexes 4, 11, 14 and 15. See also the *Quality Assurance Manual for Flight Procedure Design* (Doc 9906), Volume 3 — *Flight Procedure Design Software Validation*.

Note.— *It is not considered necessary to revise all procedures that were calculated manually. Furthermore, the simple methods remain valid as checks against major blunder errors.*

4.2 Coordinates generated by software tools will not be exactly the same as coordinates generated manually when the former uses ellipsoidal formulae and the latter uses planar formulae. Such differences are acceptable provided that they are less than the accuracy requirements detailed in the aeronautical data quality requirements of the Annexes to the Convention on International Civil Aviation.

Note.— *Coordinates generated by different software tools may not be exactly the same if the different software packages use different assumptions, apply rounding at different times or calculate different interim values.*

Section 2

GENERAL PRINCIPLES

Chapter 1

GENERAL

1.1 INTRODUCTION

1.1.1 The specifications in this part have been formulated with a view to achieving a reasonable degree of standardization although the improbability of being able to achieve worldwide uniformity of procedure, areas and obstacle clearance for any single type of facility is fully recognized. It is intended therefore that States should take into account their local conditions, in relation to these criteria, when establishing procedures, areas and obstacle clearances.

1.1.2 Only one procedure should be specified for each type of radio aid in relation to a particular runway. Exceptions to this should be permitted only after joint consideration by the State authorities and the operators concerned. The attention of States is particularly drawn, therefore, to the general and basic criteria on which the specifications have been based and the manner in which these criteria should be applied.

1.1.3 Obstacle clearance is the primary safety consideration in developing instrument approach procedures, and because of variable factors such as terrain, aircraft characteristics and pilot ability, the detailed procedures set out in this part are based on present standard equipment and practices. However, the obstacle clearance included in the specifications are considered to be the minimum: they have been evolved taking into consideration the COM and AGA specifications and it is considered that they cannot be reduced with safety.

1.1.4 The advent and burgeoning growth of RNAV procedures has meant that many pilots now habitually fly all instrument flight procedures using guidance based upon the on-board navigation database, regardless of whether the procedures are published as RNAV or conventional procedures. However, not all conventional procedures are capable of being coded into navigation databases. This is particularly the case with departure procedures. In order to mitigate this problem and to ensure improved flyability, procedure designers should:

- a) keep the design of all procedures as simple as possible;
- b) develop RNAV procedures instead of conventional procedures wherever possible;
- c) coordinate closely with the navigation database suppliers whenever introducing a conventional departure procedure;
- d) ensure continuity between SIDs and the en-route structure and between the en-route structure, STARs and approaches with the use of a common fix and compatible altitude at the interface;
- e) avoid the use of duplicate segments — i.e. a segment declared as part of a STAR and as part of an approach; and
- f) avoid the use of heading legs intercepting VOR radials with turns of less than 30°.

1.1.5 In the interest of efficiency, regularity and economy, every effort should be made to ensure that equipment is sited and procedures are evolved so as to keep to the minimum consistent with safety, both the time taken in executing an instrument approach and the airspace necessary for the associated manoeuvres.

1.2 AREAS

1.2.1 Each segment has an associated area. Normally the area is symmetrical on both sides of the intended track. In principle, this area is subdivided into primary and secondary areas. However, in some cases, only primary areas are permitted. When secondary areas are permitted, the outer half of each side of the area (normally 25 per cent of the total width) is designated as secondary area. See Figure I-2-1-1.

1.2.2 *Calculating secondary area width at a given point.* The width of the secondary areas at any point (p) between two fixes may be obtained by linear interpolation from the widths at these fixes according to the equation below (see Figure I-2-1-2):

$$W_{sp} = W_{s1} + D_p/L (W_{s2} - W_{s1})$$

- where:
- W_{s1} = width of secondary area at first fix
 - W_{s2} = width of secondary area at second fix
 - W_{sp} = width of secondary area at point p
 - D_p = distance of point p from first fix, measured along the nominal track
 - L = distance between the two fixes, measured along the nominal track

1.3 OBSTACLE CLEARANCE

Full obstacle clearance is provided throughout the entire area unless secondary areas are identified. In this case full obstacle clearance is provided in the primary area and in the secondary area the obstacle clearance is reduced linearly from the full clearance at the inner edge to zero at the outer edge. See Figure I-2-1-1.

The MOC in the secondary areas may be obtained by a linear interpolation from the full MOC at the outer edge of the primary area to zero, according to the equation below (see Figure I-2-1-3):

$$MOC_{sy} = MOC_p * (1 - Y/W_s)$$

- where:
- MOC_p = MOC in primary area
 - MOC_{sy} = MOC in secondary area for obstacle at distance Y from outer edge of primary area
 - W_s = Width of secondary area
 - Y = Distance of obstacle from the edge of the primary area, measured perpendicularly to the nominal track

1.4 EXAMPLE CALCULATIONS

All example calculations in this document are based on an altitude of 600 m (2 000 ft) above mean sea level (MSL) and a temperature of ISA + 15°C unless otherwise stated. For speed conversion the factors in the Appendix to Chapter 1 are used.

1.5 BEARINGS, TRACKS AND RADIALS

In planning procedures, degrees true shall be used. However, all published procedures shall be in degrees magnetic in accordance with Annex 4. Radials shall also be expressed in degrees magnetic, and shall further be identified as radials by prefixing the letter “R” to the magnetic bearing from the facility, for example, R-027 or R-310. The published radial shall be that radial which defines the desired flight track. In areas of magnetic unreliability (i.e. in the vicinity of the earth’s magnetic poles) procedures may be established in degrees true.

1.6 NAVIGATION SYSTEM USE ACCURACY

1.6.1 The system accuracies used in the development of obstacle clearance criteria are based on minimum system performance factors. Where it can be shown that one or more of the parameters affecting these values are confidently maintained better than the minimum, smaller accuracy values may be used. The accuracy values result from the root sum square (RSS) of the system tolerances.

1.6.2 When a navigation aid is used to provide track guidance, the tolerance of the intersection fix is based on 2 sigma confidence limits (95 per cent) while the splay of the instrument approach/missed approach procedure areas is based on 3 sigma confidence limits (99.7 per cent). For VOR/NDB tolerances, see Chapter 2, Table I-2-2-1 and Figures I-2-2-9 and I-2-2-11.

1.7 INCREASED ALTITUDES/HEIGHTS FOR MOUNTAINOUS AREAS

1.7.1 When procedures are designed for use in mountainous areas, consideration must be given to induced altimeter error and pilot control problems which result when winds of 37 km/h (20 kt) or more move over such areas. Where these conditions are known to exist, MOC should be increased by as much as 100 per cent.

1.7.2 Procedures specialists and approving authorities should be aware of the hazards involved and make proper addition, based on their experience and judgement, to limit the time in which an aircraft is exposed to lee-side turbulence and other weather phenomena associated with mountainous areas. This may be done by increasing the minimum altitude/height over the intermediate and final approach fixes so as to preclude prolonged flight at a low height above the ground. The operator’s comments should also be solicited to obtain the best local information. Such increases should be included in the State’s Aeronautical Information Publication (AIP), Section GEN 3.3.5, “Minimum flight altitude”. See Annex 15, Appendix 1 (Contents of Aeronautical Information Publication).

1.8 AREA MINIMUM ALTITUDE (AMA)

1.8.1 When determining area minimum altitude for each quadrilateral, terrain and obstacles within 8 km outside the boundaries of the quadrilateral shall be included.

1.8.2 Area minimum altitude shall be calculated to provide a minimum obstacle clearance of 600 m (2 000 ft) in mountainous areas or 300 m (1 000 ft) elsewhere above the highest obstacle within the area defined in Part III, Section 3, Chapter 7, 7.6.2.1.

1.9 CHARTING ACCURACY

1.9.1 Charting tolerance should be added to the height and location of the controlling terrain feature or obstacle when instrument approach procedures are developed. Vertical tolerance is added to the depicted height or elevation of the object. Horizontal tolerance is added to the perimeter of the controlling terrain feature or obstacle.

1.9.2 When the application of these tolerances creates an unacceptable operational penalty, additional survey information should be used to refine the obstacle location and height data.

1.10 PRESENTATION OF SIGNIFICANT OBSTACLES AND SPOT ELEVATIONS ON CHARTS

To avoid the overloading of charts with information that may potentially obscure important navigation information, careful consideration must be given by the procedures specialists when providing the following information to the cartographers:

- a) significant obstacles considered in the calculations of the relevant segments of the procedure; and
- b) appropriate spot elevations required to improve the situational awareness of the underlying terrain.

Note.— Specifications for portraying relief and significant obstacles on the Instrument Approach Chart — ICAO are set forth in Annex 4, Chapter 11.

1.11 AIRCRAFT CHARACTERISTICS DATABASE

The criteria in PANS-OPS make use of standard conditions for aircraft characteristics. However, allowance is made in the criteria to deviate from these standard conditions when specific airspace requirements apply. The characteristics for specific aircraft can be found on the ICAO website in the aircraft characteristics database (*to be developed*).

1.12 PROMULGATION

1.12.1 In planning procedures, degrees true shall be used. However, all published procedures shall be in degrees magnetic in accordance with Annex 4. Radials shall also be expressed in degrees magnetic, and shall further be identified as radials by prefixing the letter “R” to the magnetic bearing from the facility, for example, R-027 or R-310. The published radial shall be that radial which defines the desired flight track. In areas of magnetic unreliability (i.e. in the vicinity of the earth’s magnetic poles) procedures may be established in degrees true.

1.12.1.1 *Application of magnetic variation*

- a) *VOR*. Magnetic tracks to or from a VOR are determined by applying the published VOR station declination to the true VOR radial at the VOR.
- b) *NDB approach, SID, and STAR*. Magnetic tracks to or from an NDB on a procedure are determined by taking the published magnetic variation of the aerodrome and applying it to the true NDB bearing at the NDB. As an exception, when designing STARs and SIDs using long leg distances at latitudes with large variation changes, apply the magnetic variation at the 1/4 and 3/4 points of the total leg distance.

- c) *NDB en-route*. Magnetic tracks from an en-route NDB are determined by taking the published magnetic variation at the NDB and applying it to the true NDB bearing at the NDB. As an exception, when designing an en-route airway using long leg distances at high latitudes with large variation changes, apply the magnetic variation at the 1/4 and 3/4 points of the total leg distance.
- d) *ILS, MLS or localizer approach*. Magnetic courses for a localizer are determined by taking the published magnetic variation of the associated aerodrome and applying it to the true localizer course at the localizer.
- e) *NDB en-route defined fix*. Magnetic bearings from a fix defined by a bearing to an NDB are determined by applying the magnetic variation at the fix to the true bearing at the defined fix.
- f) *RNAV en-route*. For determination of the magnetic track for en-route, apply the published magnetic variation at each waypoint.
- g) *RNAV terminal procedures*. Magnetic variation to be applied to any track used in RNAV procedures, except RNAV (VOR/DME) procedures, is either the magnetic variation published for the associated aerodrome of departure/intended landing or the station declination of the recommended navaid associated with a particular procedure leg. To determine the magnetic track, apply the published magnetic variation/station declination to the procedure true track. For legs based upon CF, FA or FM path terminators, the aircraft systems use the station declination of the recommended navaid associated with the leg. It is important that suitable navaids are identified as recommended navaids for all such legs. The published magnetic variation of the aerodrome should be used for legs based upon CA, VA and VM path terminators. Magnetic variation for legs based upon other path terminators may be determined using either method. Where a station declination is used, the recommended navaid shall be clearly identified in the procedure description. Magnetic courses for RNAV (VOR/DME) procedures should use the station declination of the referenced VOR/DME for that procedure.

1.12.2 Category H procedures shall not be promulgated on the same instrument approach chart (IAC) as joint helicopter/aeroplane procedures.

1.12.3 Where different values are used they should be promulgated. However, for DME the values in Chapter 2, 2.4.4, “DME” should always be used.

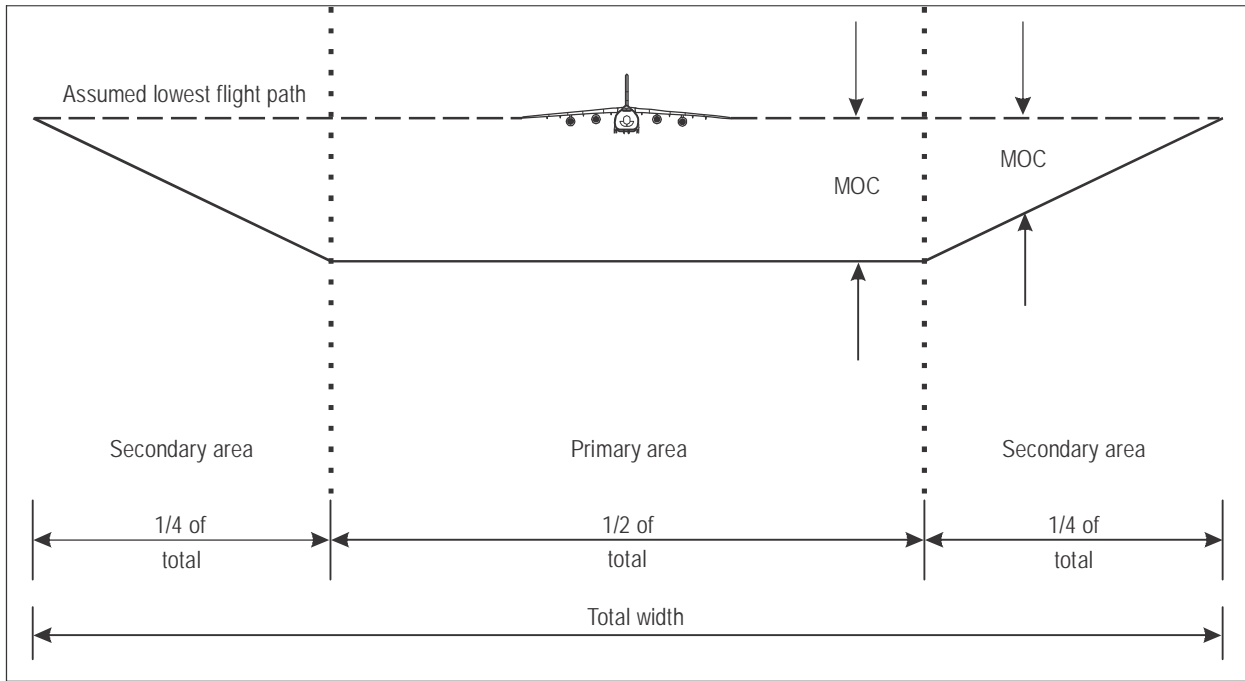

Figure I-2-1-1. Cross-section of straight segment area showing primary and secondary areas

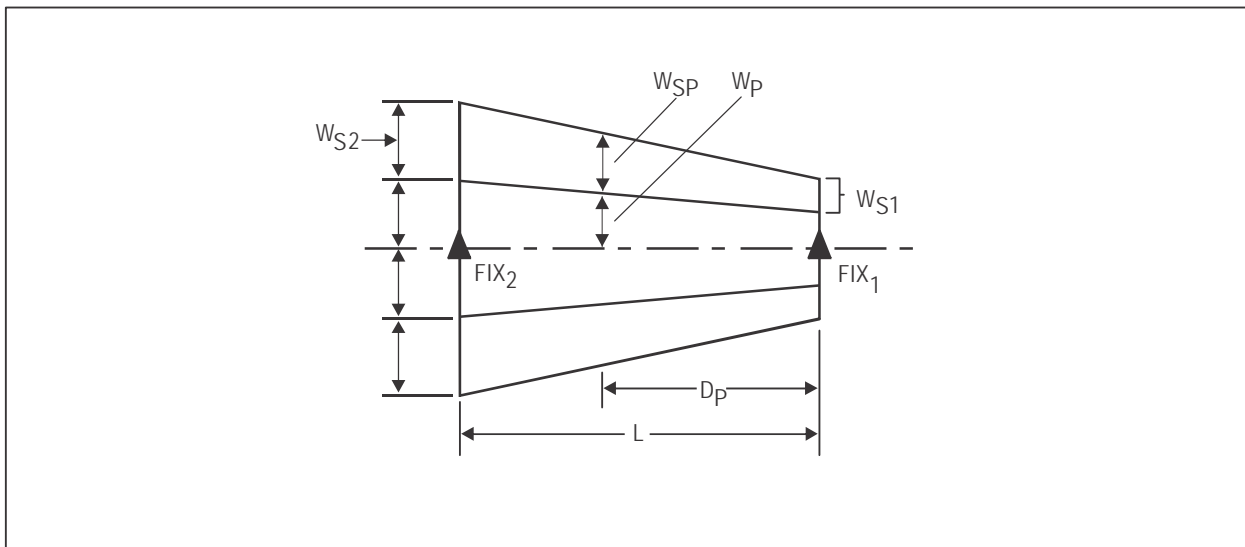

Figure I-2-1-2. Width of secondary area

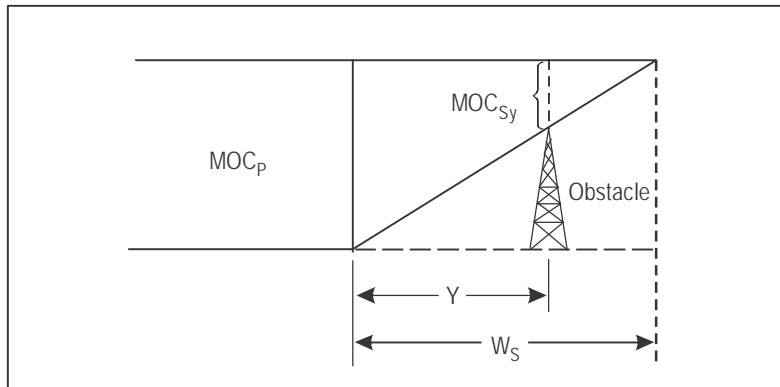

Figure I-2-1-3. Obstacle clearance in secondary areas

Appendix to Chapter 1

CONVERSION TABLE FOR IAS TO TAS CALCULATIONS

1. This appendix provides conversion factors for the conversion of indicated airspeed to true airspeed for altitudes from 0 to 7 500 m (0 to 24 000 ft) and at temperatures from ISA – 30°C to ISA + 30°C.

2. To find true airspeed, simply multiply the indicated airspeed by the conversion factor at the given altitude and temperature. For example:

a) assume an altitude of 4 500 m, an indicated airspeed of 400 km/h and a temperature of ISA + 20°C. Then

$$\text{TAS} = 400 \times 1.3034 = 521 \text{ km/h.}$$

b) assume an altitude of 10 000 ft, an indicated airspeed of 220 kt and a temperature of ISA + 10°C. Then

$$\text{TAS} = 220 \times 1.1852 = 261 \text{ kt.}$$

3. For altitudes and temperatures not listed in Tables I-2-1-App-1 and Tables I-2-1-App-2, the formula presented beneath each table can be used to determine true airspeed.

4. Because compressibility was not considered in these tables, the speeds to which the conversion factors may be applied should be limited to those listed in Tables I-4-1-1 and I-4-1-2.

Table I-2-1-App-1

<i>Altitude (metres)</i>	<i>Conversion factor</i>							
	<i>ISA–30</i>	<i>ISA–20</i>	<i>ISA–10</i>	<i>ISA</i>	<i>ISA+10</i>	<i>ISA+15</i>	<i>ISA+20</i>	<i>ISA+30</i>
0	0.9465	0.9647	0.9825	1.0000	1.0172	1.0257	1.0341	1.0508
500.0	0.9690	0.9878	1.0063	1.0244	1.0423	1.0511	1.0598	1.0770
1 000.0	0.9922	1.0118	1.0309	1.0497	1.0682	1.0774	1.0864	1.1043
1 500.0	1.0163	1.0366	1.0565	1.0760	1.0952	1.1046	1.1140	1.1325
2 000.0	1.0413	1.0623	1.0830	1.1032	1.1231	1.1329	1.1426	1.1618
2 500.0	1.0672	1.0890	1.1105	1.1315	1.1521	1.1623	1.1724	1.1923
3 000.0	1.0940	1.1167	1.1390	1.1608	1.1822	1.1928	1.2032	1.2239
3 500.0	1.1219	1.1455	1.1686	1.1912	1.2135	1.2245	1.2353	1.2568

Altitude (metres)	Conversion factor							
	ISA-30	ISA-20	ISA-10	ISA	ISA+10	ISA+15	ISA+20	ISA+30
4 000.0	1.1507	1.1753	1.1993	1.2229	1.2460	1.2574	1.2687	1.2910
4 500.0	1.1807	1.2063	1.2313	1.2558	1.2798	1.2917	1.3034	1.3266
5 000.0	1.2119	1.2385	1.2645	1.2900	1.3150	1.3273	1.3395	1.3636
5 500.0	1.2443	1.2720	1.2991	1.3256	1.3516	1.3644	1.3771	1.4022
6 000.0	1.2779	1.3068	1.3350	1.3627	1.3897	1.4031	1.4163	1.4424
6 500.0	1.3130	1.3430	1.3725	1.4013	1.4295	1.4434	1.4572	1.4843
7 000.0	1.3494	1.3808	1.4115	1.4415	1.4709	1.4854	1.4998	1.5281
7 500.0	1.3873	1.4201	1.4521	1.4835	1.5141	1.5292	1.5442	1.5737

The following formula is used for values not listed in the table:

$$TAS = IAS \times 171233 [(288 \pm VAR) - 0.006496H]^{0.5} \div (288 - 0.006496H)^{2.628}$$

where: VAR = Temperature variation about ISA in °C, H = Altitude in metres.

Table I-2-1-App-2

Altitude (feet)	Conversion factor							
	ISA-30	ISA-20	ISA-10	ISA	ISA+10	ISA+15	ISA+20	ISA+30
0	0.9465	0.9647	0.9825	1.0000	1.0172	1.0257	1.0341	1.0508
1 000.0	0.9601	0.9787	0.9969	1.0148	1.0324	1.0411	1.0497	1.0667
2 000.0	0.9740	0.9930	1.0116	1.0299	1.0479	1.0567	1.0655	1.0829
3 000.0	0.9882	1.0076	1.0266	1.0453	1.0637	1.0728	1.0818	1.0995
4 000.0	1.0027	1.0225	1.0420	1.0611	1.0799	1.0892	1.0984	1.1165
5 000.0	1.0175	1.0378	1.0577	1.0773	1.0965	1.1059	1.1153	1.1339
6 000.0	1.0327	1.0534	1.0738	1.0938	1.1134	1.1231	1.1327	1.1517
7 000.0	1.0481	1.0694	1.0902	1.1107	1.1307	1.1406	1.1505	1.1699
8 000.0	1.0639	1.0857	1.1070	1.1279	1.1485	1.1586	1.1686	1.1885
9 000.0	1.0801	1.1024	1.1242	1.1456	1.1666	1.1770	1.1872	1.2075

Altitude (feet)	Conversion factor							
	ISA-30	ISA-20	ISA-10	ISA	ISA+10	ISA+15	ISA+20	ISA+30
10 000.0	1.0967	1.1194	1.1418	1.1637	1.1852	1.1958	1.2063	1.2270
11 000.0	1.1136	1.1369	1.1597	1.1822	1.2042	1.2150	1.2258	1.2470
12 000.0	1.1309	1.1547	1.1781	1.2011	1.2236	1.2347	1.2457	1.2674
13 000.0	1.1485	1.1730	1.1970	1.2205	1.2435	1.2549	1.2661	1.2884
14 000.0	1.1666	1.1917	1.2162	1.2403	1.2639	1.2755	1.2871	1.3098
15 000.0	1.1852	1.2108	1.2360	1.2606	1.2848	1.2967	1.3085	1.3318
16 000.0	1.2041	1.2304	1.2562	1.2814	1.3062	1.3184	1.3305	1.3544
17 000.0	1.2235	1.2505	1.2769	1.3028	1.3281	1.3406	1.3530	1.3775
18 000.0	1.2434	1.2710	1.2981	1.3246	1.3506	1.3634	1.3761	1.4011
19 000.0	1.2637	1.2921	1.3198	1.3470	1.3736	1.3868	1.3998	1.4254
20 000.0	1.2846	1.3136	1.3421	1.3700	1.3973	1.4107	1.4240	1.4503
21 000.0	1.3059	1.3357	1.3649	1.3935	1.4215	1.4353	1.4489	1.4759
22 000.0	1.3278	1.3584	1.3883	1.4176	1.4463	1.4605	1.4745	1.5021
23 000.0	1.3502	1.3816	1.4123	1.4424	1.4718	1.4863	1.5007	1.5290
24 000.0	1.3731	1.4054	1.4369	1.4677	1.4980	1.5128	1.5276	1.5566

The following formula is used for values not listed in the table:

$$\text{TAS} = \text{IAS} \times 171233 [(288 \pm \text{VAR}) - 0.00198\text{H}]^{0.5} \div (288 - 0.00198\text{H})^{2.628}$$

where: VAR = Temperature variation about ISA in °C, H = Altitude in feet.

Chapter 2

TERMINAL AREA FIXES

2.1 GENERAL

2.1.1 Because all navigation facilities and waypoints have accuracy limitations, the geographic point which is identified is not precise, but may be anywhere within an area which surrounds the nominal point. The nominal point can be defined by:

- a) an intersection (see 2.3, “Fix tolerance and fix tolerance area for intersecting fixes”);
- b) overheading a facility (see 2.5, “Fix tolerance overheading a station”);
- c) an RNAV waypoint; and
- d) other kinds of navigation aids (see 2.4, “Fix tolerance for other types of navigation instruments”).

2.1.2 As an example, Figure I-2-2-1 illustrates the intersection of an arc and a radial from the same VOR/DME facility, as well as the intersection of two radials or bearings from different navigation facilities. The area of intersection formed in this way is referred to in this document as the “fix tolerance area”.

2.2 TERMINAL AREA FIXES

2.2.1 Terminal area fixes include, but are not limited to:

- a) the initial approach fix (IAF);
- b) the intermediate approach fix (IF);
- c) the final approach fix (FAF); and
- d) the holding fix,

and when necessary, a fix to mark the missed approach point (MAPt), or the turning point (TP).

2.2.2 Terminal area fixes should be based on similar navigation systems. The use of mixed type (as VHF/LF) fixes should be limited to those intersections where no satisfactory alternative exists.

2.3 FIX TOLERANCE AND FIX TOLERANCE AREA FOR INTERSECTING FIXES

The fix tolerance and fix tolerance area are obtained by using navigation information from either collocated or non-collocated facilities as shown in Figure I-2-2-1.

2.3.1 Fix tolerance areas

The fix tolerance areas are formed by the boundaries obtained from system use accuracies of the homing and intersecting radials (or arcs as appropriate) with respect to the nominal fix position. As the system use accuracy is expressed in angles, the size of the fix tolerance area is dependent on the distance of the fix to navigation aids.

2.3.2 Fix tolerance

The fix tolerance determines the operational acceptability of a fix. Fix tolerance is a distance measured along the nominal track and relative to the nominal fix position. It is defined by the intersections of the nominal track with the earliest and latest limits of the fix tolerance area, measured along the nominal track. The tolerance is expressed as a plus or minus value around the nominal fix. See Figures I-2-2-5 and I-2-2-6. Fix tolerance and system use accuracies are based on a 95 per cent probability of containment (2 SD).

2.3.3 System use accuracy for VOR, NDB and LOC

System use accuracy is based on a root sum square calculation using the following tolerances:

- a) ground system tolerance;
- b) airborne receiving system tolerance; and
- c) flight technical tolerance.

Difference between the overall system use accuracy of the intersecting facility and the along track facility is accounted for by the fact that flight technical tolerance is not applied to the former. See Table I-2-2-1 for system use accuracies and Table I-2-2-2 for the tolerances on which these values are based.

2.4 FIX TOLERANCE FOR OTHER TYPES OF NAVIGATION INSTRUMENTS

2.4.1 Terminal area radar

Radar fix accuracies need to consider:

- a) mapping accuracies (normally 150 m (492 ft) or 3 per cent of the distance to the antenna);
- b) azimuth resolutions of the radar (reduced to some extent to account for the controller interpretation of target centre);
- c) flight technical tolerance (which recognizes communication lag as well as speed of the aircraft); and
- d) controller technical tolerance (which recognizes sweep speed of the antenna and the speed of the aircraft).

The total fix tolerance is the result of a combination, on a root sum square (RSS) basis, as in Table I-2-2-3.

2.4.2 Radar fixes

Radar should not normally be the primary method of fix identification. However, where air traffic control (ATC) can provide the service, terminal area radar (TAR) within the limitations specified in 2.4.1, “Terminal area radar” may be used to identify any terminal area fix. En-route surveillance radar (RSR) may be used for initial approach and intermediate approach fixes.

2.4.3 Fixes for VOR or NDB with DME

2.4.3.1 VOR/DME fixes use radial and distance information derived normally from facilities with collocated azimuth and DME antennas. However, where it is necessary to consider a VOR/DME fix derived from separate facilities, the fix is only considered satisfactory where the angles subtended by the facilities at the fix results in an acceptable fix tolerance area. See Figure I-2-2-1.

2.4.3.2 Where the DME antenna is not collocated with the VOR and NDB providing track guidance, the maximum divergence between the fix, the tracking facility and the DME shall not be more than 23 degrees.

2.4.3.3 For the use of DME with ILS, see Part II, Section 1, Chapter 1, 1.4.4, “Glide path verification check”.

2.4.4 DME

The accuracy is $\pm (0.46 \text{ km (0.25 NM)} + 1.25 \text{ per cent of the distance to the antenna})$. This value is the RSS total of minimum accuracy, monitor tolerance and flight technical tolerance, the latter two being so small as to be completely dominated by the larger airborne value.

Note 1.— No reduction can be justified based on flight test information.

Note 2.— Tolerance values assume that published procedures will take into account slant range distance.

2.4.5 75 MHz marker beacon

Use to determine the fix tolerance for ILS and “Z” markers during approach procedures.

If the facility defines the MAPt, the fixed value of zero is used (see Section 4, Chapter 6, 6.1.6.2.1, “MAPt tolerance when MAPt is defined by a navigation facility or fix”).

2.5 FIX TOLERANCE OVERHEADING A STATION

2.5.1 VOR

2.5.1.1 The fix tolerance area overhead a VOR is based on the circular, horizontal section of the inverted cone of ambiguity over the facility, with its apex at the facility and a cone semi-angle (α) of 50 degrees. However, where a State has determined that a different angle is appropriate, the radius of the circular area of ambiguity may be adjusted using the formula in 2.5.1.2 below. Entry into the cone is assumed to be achieved within an accuracy of $\pm 5^\circ$ from the prescribed inbound track. From the points of entry, tracking through the cone is assumed to be achieved within an accuracy of $\pm 5^\circ$. If the facility defines the MAPt or the turning point in the missed approach, fixed values are used (see Section 4, Chapter 6, 6.1.6.2.1 and 6.4.6.2).

2.5.1.2 *VOR position fix tolerance area construction.* The VOR position fix tolerance area V1, V2, V3, V4 is determined as follows (see Figure I-2-2-3):

- 1) draw a circle with centre on the VOR and a radius of zV :
 $zV = h \tan \alpha$ (zV and h in km)
 $zV = 0.164 h \tan \alpha$ (h in thousands of feet and zV in nautical miles)
 where α is 50° or another value, as determined by the appropriate authority, corresponding to the cone effect;
 and h the height above the facility;
- 2) draw the parallel lines at a distance $qV = zV \sin 5^\circ$ on each side of the inbound track;
- 3) draw two lines making an angle of 5° with the preceding lines 2) on the points “V2” and “V4”; and
- 4) locate points “V1” and “V3” at the intersections of the lines 3) and the circle 1).

2.5.2 NDB

2.5.2.1 The fix tolerance area overhead an NDB is based on the circular, horizontal section of the inverted cone of ambiguity over the facility, with its apex at the facility and a cone semi-angle of 40 degrees. Entry into the cone is assumed to be achieved within an accuracy of $\pm 15^\circ$ from the prescribed inbound track. From the points of entry, tracking through the cone is assumed to be achieved within an accuracy of $\pm 5^\circ$. If the facility defines the MAPt or the turning point in the missed approach, fixed values are used (see Section 4, Chapter 6, 6.1.6.2.1 and 6.4.6.2).

2.5.2.2 *NDB position fix tolerance area construction.* The NDB position fix tolerance area N1 N2 N3 N4 is determined as follows (see Figure I-2-2-4):

- 1) draw a circle with centre on the NDB and a radius zN :
 $zN = h \tan 40^\circ$ (zN and h in km)
 $zN = 0.164 h \tan 40$ (h in thousands of feet and zN in nautical miles) to obtain the cone effect area;
- 2) draw the parallel lines at a distance $qN = zN \sin 15^\circ$ on each side of the inbound track;
- 3) draw two lines making an angle of 5° with the preceding lines 2) on the points “N2” and “N4”; and
- 4) locate points “N1” and “N3” at the intersections of the lines 3) and the circle 1).

2.6 OPERATIONAL APPLICATION OF FIXES FOR FLIGHT PROCEDURE PLANNING

2.6.1 Minimum usable ground distance to a VOR/DME fix

The minimum usable ground distance to a VOR/DME fix can be determined from the following equations.

$$d_m = h_1 \tan 55^\circ$$

where: h_1 = height above the facility in thousands of metres; and
 d_m = minimum usable DME ground distance in kilometers

or

$$d_m = 0.164 h_1 \tan 55^\circ$$

where: h_1 = height above the facility in thousands of feet; and
 d_m = minimum usable DME ground distance in nautical miles.

2.6.2 Initial/Intermediate approach fix

To be satisfactory as an intermediate or initial approach fix, the fix tolerance (along track tolerance (ATT) for RNAV) must not be larger than ± 3.7 km (± 2.0 NM) with the following exception. When the FAF is a VOR, NDB or VOR/DME fix, the fix tolerance may be increased to not greater than ± 25 per cent of the corresponding segment's length (intermediate or initial, as appropriate).

Example: If the intermediate or initial segment is 10 NM in length, then the fix tolerance may be 2.5 NM.

Measurements are made from the nominal fix positions along the nominal flight track. See Figure I-2-2-5.

2.6.3 Final approach fix for non-precision approaches

For use as a FAF, the fix shall be located not farther than 19 km (10 NM) from the landing surface. The fix tolerance at the FAF crossing level should not exceed ± 1.9 km (1.0 NM). See Figure I-2-2-6.

2.6.4 Missed approach fixes

2.6.4.1 General

A missed approach fix may be used in non-precision approaches. The fix tolerance shall not exceed the longitudinal tolerance of the MAPt calculated assuming that the MAPt is defined by a distance from the FAF. See Section 4, Chapter 6.

2.6.4.2 Use of 75 MHz marker beacon

The use of an ILS 75 MHz marker as an MAPt is limited to the case of ILS approach with glide path unserviceable. See Part II, Section 2, Chapter 1, "Localizer only".

2.6.5 Limiting radials/DME distances

Where no missed approach track guidance is available a turn point can be defined by the intersection of the nominal track with a limiting VOR radial, NDB bearing or DME distance. Although this is not a fix, the missed approach calculations are made by assuming a fix tolerance area drawn as shown on Figure I-2-2-7 (see Section 4, Chapter 6, 6.4.6 and Part II, Section 1, Chapter 1, 1.5.3.3 for turn area).

2.7 USE OF FIXES FOR DESCENT AND RELATED OBSTACLE CLEARANCE

2.7.1 Distance available for descent

When applying descent gradient criteria to an approach segment (initial, intermediate or final approach areas), the gradient is calculated between the nominal positions of the related fixes. See Figure I-2-2-8.

2.7.2 Obstacle clearance after passing a fix

It is assumed that descent will begin at the earliest point within the fix tolerance area of the first fix and will end at the nominal position of the second fix. Obstacle clearance appropriate to the segment being entered shall be provided:

- a) within the fix tolerance area of the first fix; and
- b) between the nominal positions of the two fixes.

See Figure I-2-2-9 for an example of an intermediate approach segment.

2.7.3 Stepdown fix

2.7.3.1 A stepdown fix permits additional descent within a segment by identifying a point at which a controlling obstacle has been safely overflown. Preferably, only one stepdown fix should be established in the final approach segment, except in the case where the fix can be provided by radar or DME. In this case no more than two stepdown fixes should be specified. See Figure I-2-2-10.

2.7.3.2 The use of the stepdown fix in the final approach segment shall be limited to aircraft capable of simultaneous reception of the flight track and a crossing indication unless otherwise specified. Where a stepdown fix is used in the final approach segment, an OCA/H shall be specified both with and without the stepdown fix. Where a stepdown fix is used in the final approach segment of an RNP procedure, OCA/H is specified only for the case with stepdown fix.

2.7.3.3 A stepdown fix should meet the criteria which apply to the fix associated with that segment. That is:

- a) the criteria for the IAF and the IF in the initial and intermediate approach segments respectively; and
- b) the criteria for the FAF in the final approach segment.

The criteria for the IAF and the IF are shown in 2.6.2 above. The criteria for the FAF are shown in 2.6.3.

2.7.3.4 Where fixes can be provided by a suitably located DME, a series of descending steps on a specified track or within a specified sector converging to the aerodrome of landing may be constructed. This procedure shall be designed to provide obstacle clearance appropriate to the segment in which the fix is located, from the en-route phase of flight through the final approach segment.

2.7.4 Obstacle close to a final approach fix or stepdown fix

Obstacles that are within the fix tolerance area and are no more than 9.3 km (5.0 NM) past the earliest point of the fix tolerance area need not be considered in establishing the OCA/H or the minimum obstacle clearance altitude/height of the following segment provided that these obstacles are found under a plane:

- a) perpendicular to the vertical plane containing the nominal final approach flight path and on a 15 per cent horizontal gradient (Cat H, 15 per cent or descent gradient of the nominal track multiplied by 2.5, whichever is greater); and
- b) passing through the earliest point of the fix tolerance area at an altitude/height equal to the minimum obstacle clearance altitude/height prior to the fix, minus the obstacle clearance required for the segment preceding the fix. (See Figure I-2-2-11.)

2.8 PROTECTION AREA FOR VOR AND NDB

The values for protection areas are based on the system use accuracies (2 SD) shown in Table I-2-2-1 and are extrapolated to a 3 SD value (99.7 per cent probability of containment).

VOR splay:
Terminal = 7.8°
NDB splay:
Terminal = 10.3°

Table I-2-2-1. System use accuracy (2SD) of facility providing track guidance and facility not providing track guidance

	VOR ¹	ILS	NDB
System use accuracy of facility NOT providing track	+/- 4.5°	+/- 1.4°	+/- 6.2°
System use accuracy of facility providing track	+/- 5.2°	+/- 2.4°	+/- 6.9°

1. The VOR values of +/- 5.2° and +/- 4.5° may be modified according to the value of a) in Table I-2-2-2, resulting from flight tests.

Table I-2-2-2. Tolerances on which system use accuracies are based

The values in Table I-2-2-1 are the result of a combination, on a root sum square basis, of the following tolerances	VOR	ILS	NDB
a) ground system tolerance	+/- 3.6°	+/- 1° ¹	+/- 3°
b) airborne receiving tolerance	+/- 2.7°	+/- 1°	+/- 5.4°
c) flight technical tolerance ²	+/- 2.5°	+/- 2°	+/- 3°

1. Includes beam bends.
2. Flight technical tolerance is only applied to navigation aids providing track. It is not applied to fix intersecting navigation aids.

Table I-2-2-3. Terminal area radar — total fix tolerance

<i>Parameter</i>	<i>TAR</i>		<i>RSR</i>	
	<i>within 37 km (20 NM)</i>		<i>within 74 km (40 NM)</i>	
Video map accuracy	1.1 km	0.6 NM	2.2 km	1.2 NM
Azimuth accuracy	0.7 km	0.4 NM	1.5 km	0.8 NM
Flight technical tolerance	0.7 km (5 s at 500 km/h)	0.3 NM (5 s at 250 kt)	1.4 km (10 s at 500 km/h)	0.7 NM (10 s at 250 kt)
Controller technical tolerance	0.6 km	0.3 NM	1.1 km	0.6 NM
Total fix tolerance (RSS'd)	± 1.6 km	± 0.8 NM	± 3.2 km	± 1.7 NM

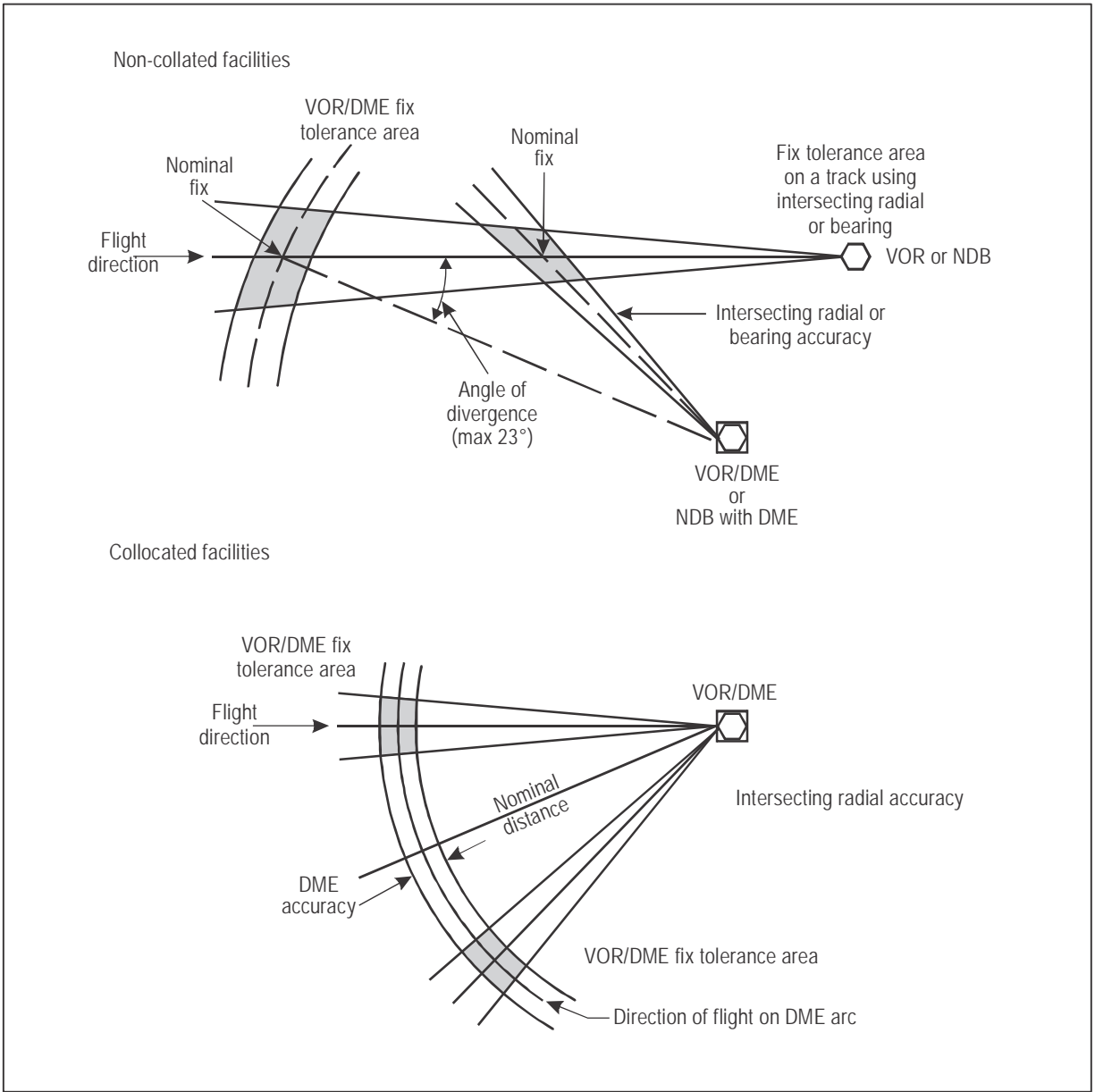

Figure I-2-2-1. Intersection fix tolerance areas

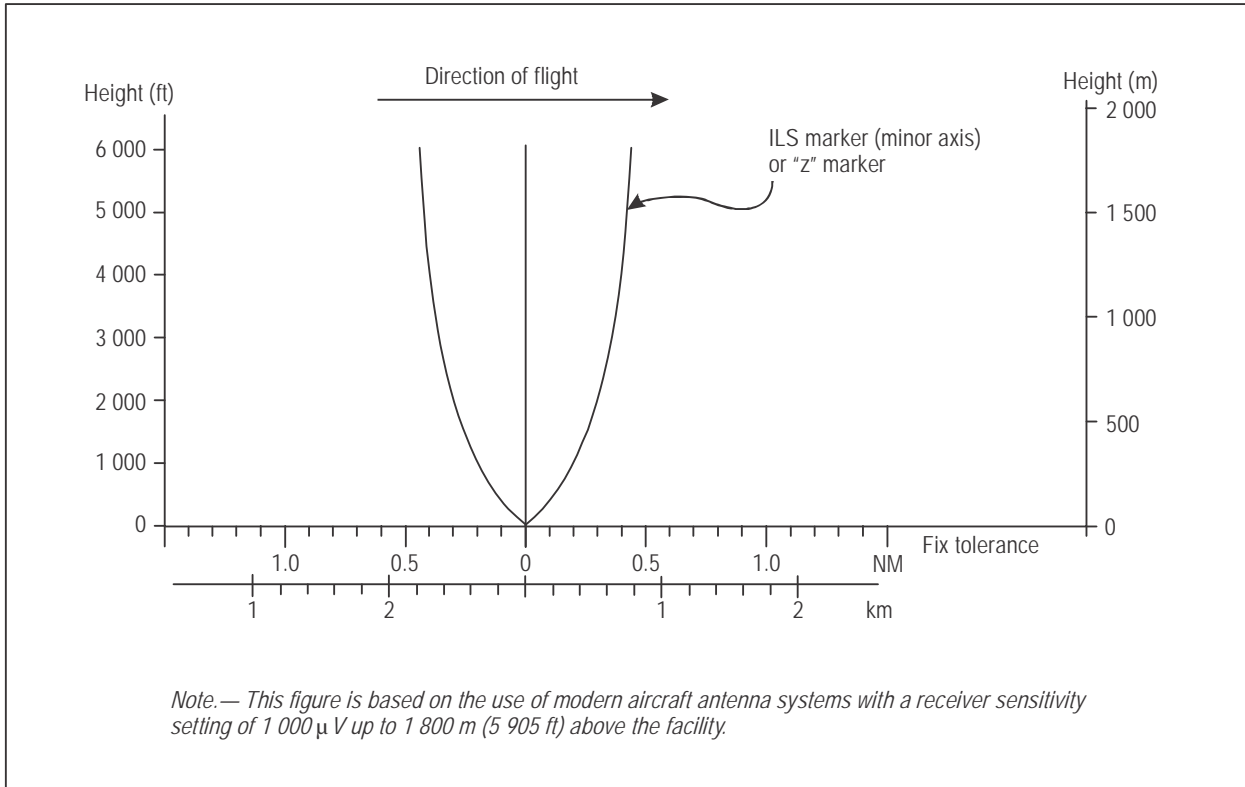

Figure I-2-2-2. ILS or "Z" marker coverage

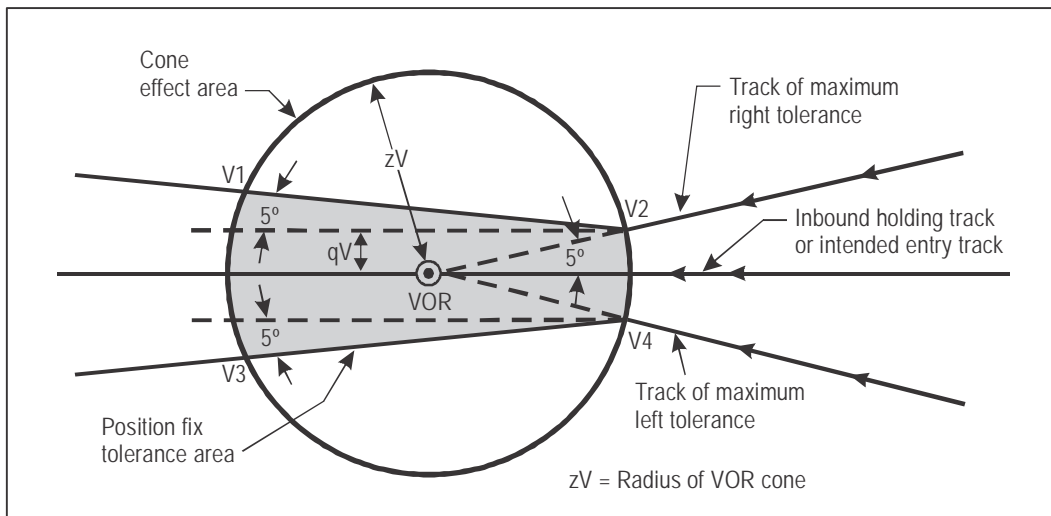

Figure I-2-2-3. Fix tolerance area overhead a VOR

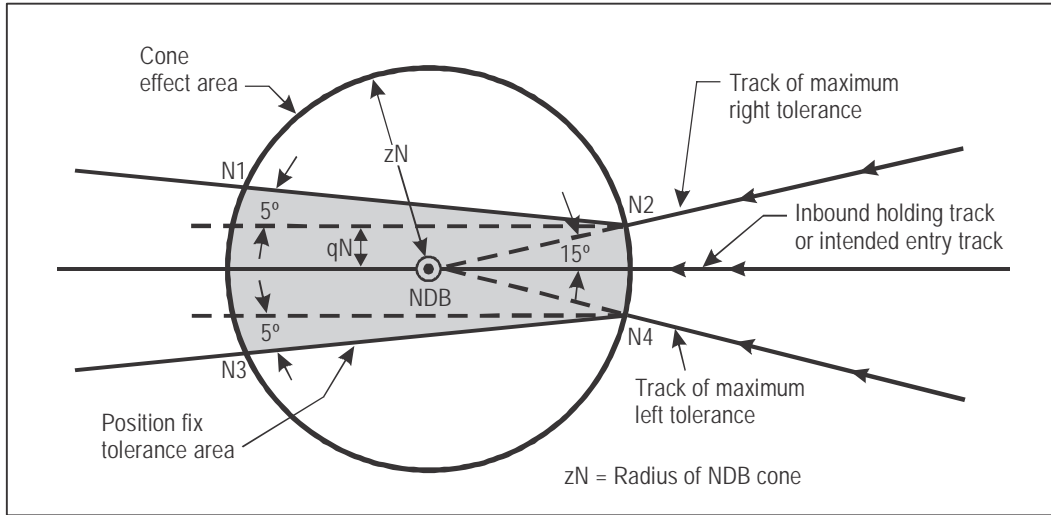

Figure I-2-2-4. Fix tolerance area overhead an NDB

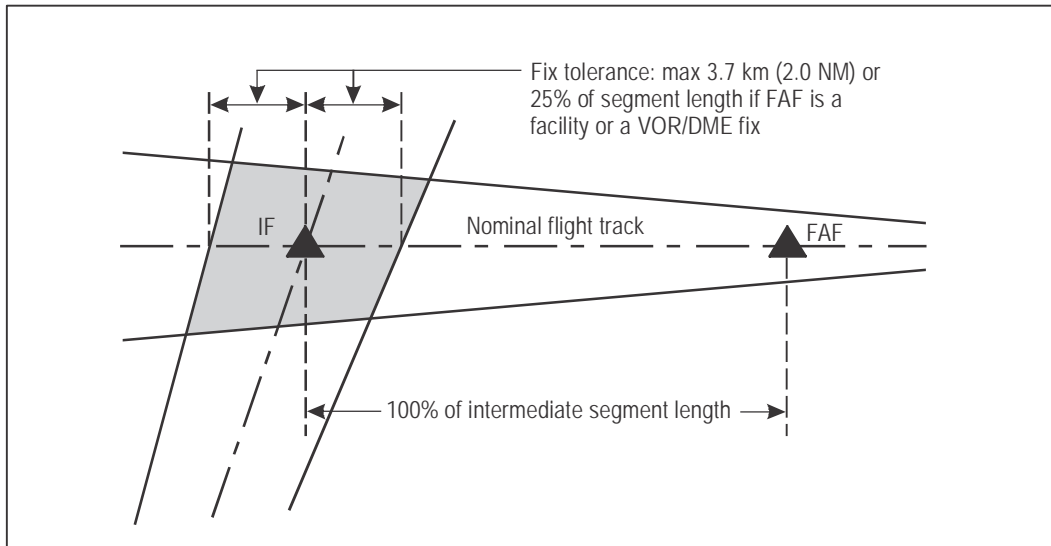

Figure I-2-2-5. Fix tolerance in the immediate approach segment

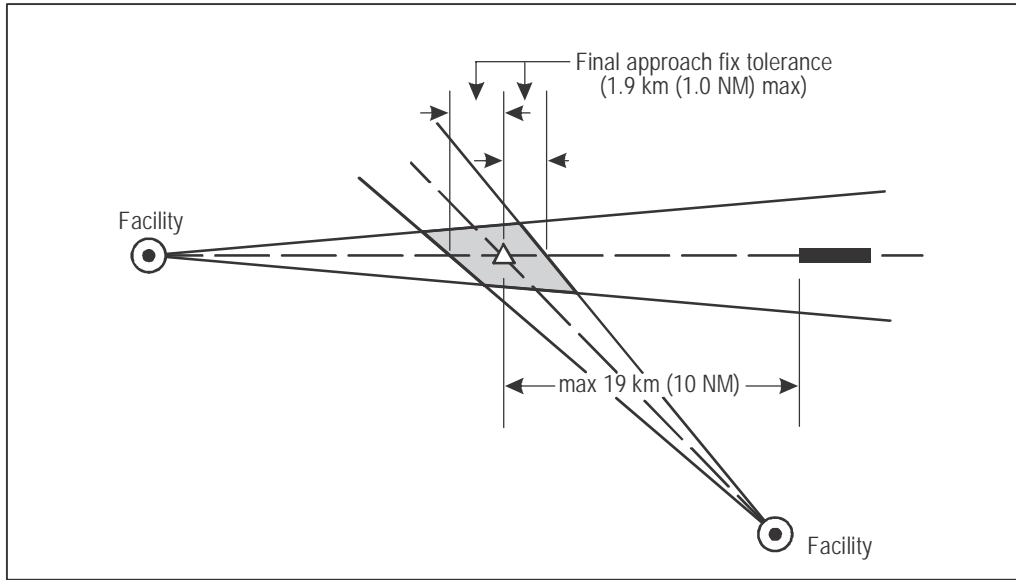

Figure I-2-2-6. Final approach fix (FAF) tolerance

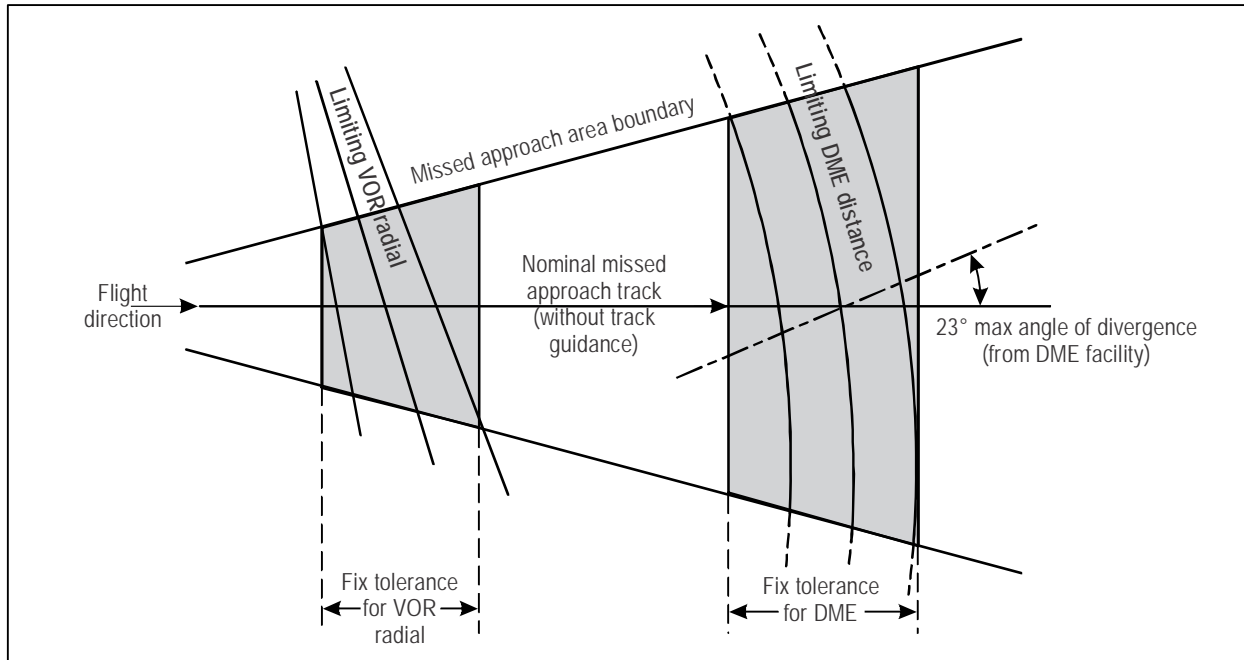

Figure I-2-2-7. Assumed fix tolerance areas for limiting radial/bearing or DME distance

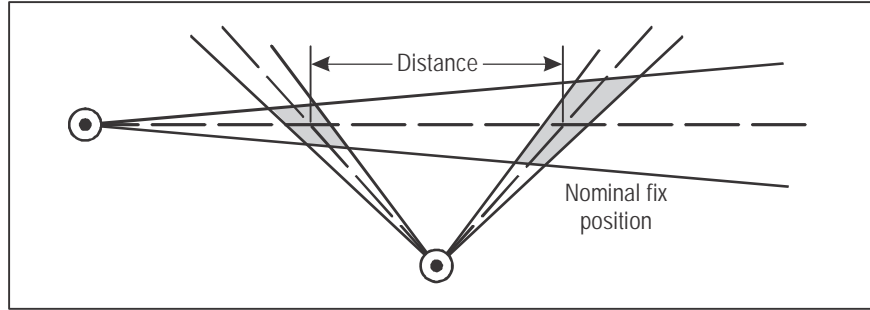

Figure I-2-2-8. Distance between fixes

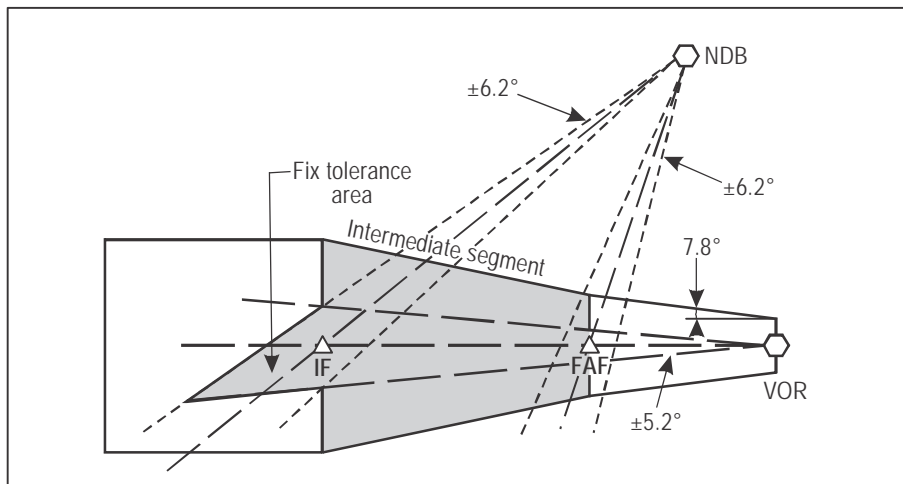

Figure I-2-2-9. Area requiring obstacle clearance

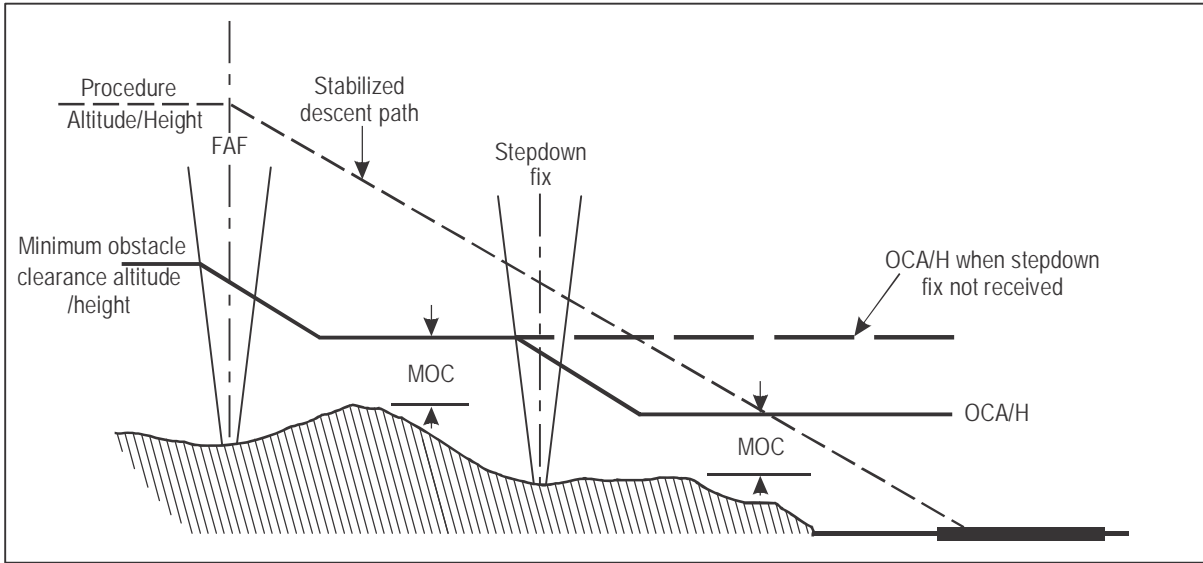

Figure I-2-2-10. Stepdown fix with dual OCA/H

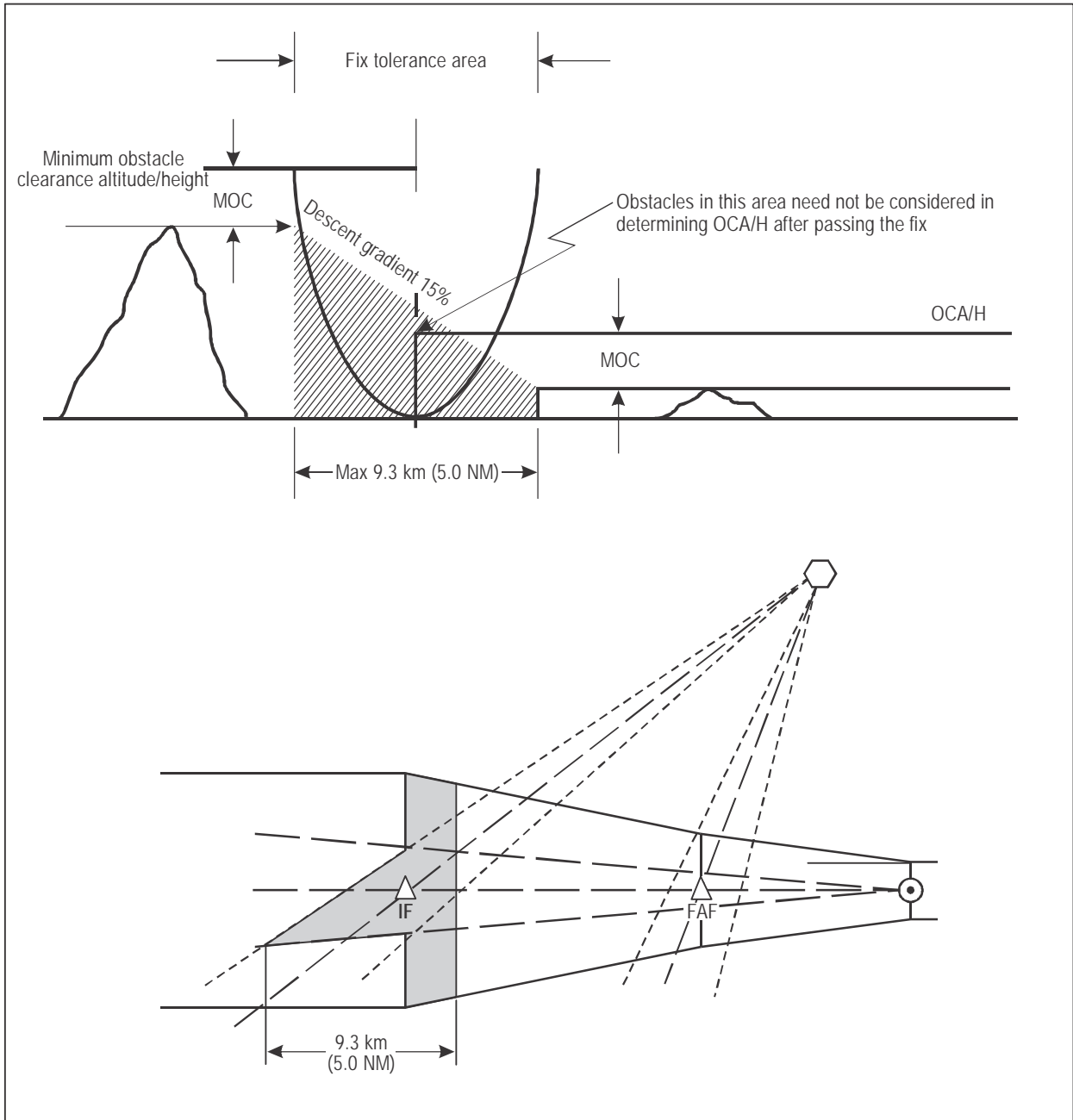

Figure I-2-2-11. Area where obstacles need not be considered

Chapter 3

TURN AREA CONSTRUCTION

3.1 GENERAL

3.1.1 This chapter describes the general criteria for the construction of turn areas for use in the different segments of instrument flight procedures. The methodologies presented — wind spiral and bounding circle — apply to the phases of flight shown below. All other turns are constructed by means of arcs (see the appropriate chapters).

- a) Departure.
- b) Missed approach.
- c) Final approach fix (turns > 10 degrees).
- d) RNAV turns at the IAF and IF (turns > 30 degrees).

3.1.2 Turn parameters

3.1.2.1 This section shows the parameters on which the turn areas are based, together with the variables which represent them in the drawings. The values for the following parameters vary according to the phase of flight. Their values are listed in Table I-2-3-1, “Turn construction parameter summary”. For the specific application of the parameters in the table, see the applicable chapters. Tables I-2-3-2 and I-2-3-3 show example calculations of various turning parameters for a selection of IAS.

- a) Altitude.
- b) Indicated airspeed (IAS).
- c) Wind.
- d) Bank angle (α).
- e) Flight technical tolerances.

3.1.2.2 Other turn factors and calculations used in turn construction

- a) *Fix tolerance*. As appropriate for the type of fix. See Section 2, Chapter 2, “Terminal area fixes”. See also Part II, Section 3, “En-route criteria”.
- b) *Rate of turn (R) in degrees/second*. This is calculated as follows:
 - 1) $R = (6\,355 \tan \alpha) / \pi V$, where V is the TAS in km/h; and

- 2) $R = (3\,431 \tan \alpha) / \pi V$, where V is the TAS in kt;
up to a maximum value of 3 degrees/second.
- c) *Radius of turn (r) at a designated angle of bank in still air, in km or NM as appropriate.* The turn radius for a given value of R is derived as follows:
 $r = V / (20 \pi R)$ where V is the TAS.
- d) *Wind effect (E_θ) for the time taken to change heading θ degrees, in km or NM as appropriate.*
- e) *Gravity.* The value used implicitly in the formulae is 9.80665 m/s^2 ($68\,625 \text{ NM/hour}^2$).
- f) c = pilot reaction time (see Table I-2-3-1 for values applicable to each phase of flight).

3.2 TURN INNER BOUNDARY CONSTRUCTION

3.2.1 Turn at an altitude/height

The inner boundary normally originates at the beginning of the turn initiation area from whichever edge of the area provides the best lateral protection (inner edge if turn $< 75^\circ$, outer edge if turn $\geq 75^\circ$). It then diverges outwards in the direction of the nominal track with a splay of 15 degrees (see Figures I-2-3-1 a) and b)).

3.2.2 Turns at a designated turning point

On the inner edge of the turn, the primary area boundary starts at the K-line. The edges of the primary and secondary areas are connected to their counterparts in the subsequent sections. For these connections, the following rules apply:

- a) if the point to connect is outside the protection area associated with the subsequent section, then the boundary converges with the nominal track after the turn at an angle equal to half the angle of turn ($A/2$); and
- b) if the point to connect is inside the protection area associated with the subsequent section, then the boundary diverges from the nominal track at an angle of 15 degrees.

3.3 TURN OUTER BOUNDARY CONSTRUCTION

3.3.1 General construction principles

Construction principles are as follows:

- a) The curve begins at Point A (see Figure I-2-3-2). The parameters that determine its location are:
 - 1) fix tolerance; and
 - 2) flight technical tolerance;

- b) from this point there are two methods for constructing the curving portion of the turn outer boundary:
 - 1) by calculating the wind spiral. (See 3.3.2, “Turn area using wind spiral”); or
 - 2) by drawing bounding circles (simplified method). See 3.3.3, “Turn area using bounding circles”; and
- c) at point P where the tangent of the area becomes parallel to the nominal track after the turn the boundary is formed as follows:
 - 1) if no track guidance is available, the outer boundary starts to splay at 15 degrees relative to the nominal track (see Figure I-2-3-3 a); and
 - 2) if track guidance is available, see 3.3.4, “Additional track guidance”.

3.3.2 Turn area using wind spiral

3.3.2.1 In the wind spiral method, the area is based on a radius of turn calculated for a specific value of true airspeed and bank angle. The outer boundary of the turn area is constructed using a spiral derived from the still air radius of turn (r). The resultant spiral is created from applying wind effect E_θ for the time taken to change heading by θ degrees using the formulae:

$$E_\theta = (\theta/R) * (w/3600) \text{km (NM)}$$

where θ is the angle of turn, R the rate of turn and w the wind speed.

Note.— An automated version of the wind effect calculation appears on the PANS-OPS Software CD ROM (CD-101) under the Tools menu.

3.3.2.2 The wind spiral is based on the calculation of E_θ at each specified interval (e.g. 30°). The accuracy can be increased by decreasing the interval. The construction is based on the following steps (See Figure I-2-3-4):

- 1) locate points b_1, c_1, \dots, n_1 by adding a distance of E_θ , perpendicular to the still air radius (r);
- 2) calculate points b_2, c_2, \dots, n_2 , located at an angle $\arcsin(w/V)$ prior b_1, c_1, \dots, n_1 and distance E_θ from point b, c, \dots, n respectively; and
- 3) the spiral result from tracing a curve starting at point “a”, located on the still air radius passing to b_2, c_2, \dots, n_2 .

3.3.3 Turn area using bounding circles

As an alternative to the wind spiral, a simplified method can be used in which circles are drawn to bound the turning area. See Figure I-2-3-5.

Unlike the wind spiral method, the wind effect (E) used here is always that of a course change of 90° .

The construction method is:

- 1. Start at point A on the outer edge of the area.
- 2. At a distance r from point A, abeam the nominal flight path, construct a circle having radius E .

3. From point X, draw an arc having the following radius:

$$\sqrt{r^2 + E^2}$$

This begins the boundary for turns between 0 and 90 degrees.

4. Start at point A' on the inner edge of the turn.
 5. At a distance r from point A' , abeam the nominal flight path, construct a second circle having radius E.
 6. From point X', draw an arc having the following radius:

$$\sqrt{r^2 + E^2}$$

This completes the boundary for turns between 0 and 90 degrees.

7. Connect the two arcs described in steps 3 and 6.
 8. From point Y, draw an arc having the following radius:

$$r + E$$

This extends the boundary for turns between 90 and 180 degrees.

9. From point Z, draw an arc having the following radius:

$$r + 2E$$

This extends the boundary for turns between 180 and 270 degrees.

Note.— An automated version of the wind effect calculation appears on the PANS-OPS Software CD ROM (CD-101) under the tools menu.

3.3.4 Additional track guidance

3.3.4.1 After the turn an operational advantage may be obtained by using suitably located facilities to reduce the dimensions of the area. Examples of typical turning areas with additional track guidance are shown in Figure I-2-3-3 b) to d).

3.3.4.2 If the point (P) where the tangent of the wind spiral or bounding circle becomes parallel to the nominal track after the turn is:

- a) outside the navigation aid tolerance:
- 1) for flights towards the navigation aid: connect the outer boundary to the edge of the navigation aid tolerance at the navigation aid location. (See Figure I-2-3-3 b));
 - 2) for flights away from the navigation aid: connect the outer boundary to the edge of the navigation aid tolerance with a line parallel to the nominal track. (See Figure I-2-3-3 c)); and
- b) inside the navigation aid tolerance: connect the outer boundary to the edge of the navigation aid tolerance with a line splayed from the nominal track at an angle of 15 degrees. (See Figure I-2-3-3 d).)

3.3.5 Secondary areas with additional track guidance

3.3.5.1 A secondary area can be created on the outer side of the turn as soon as the aircraft has track guidance. On the outer edge of the turn this area is based on a 30° line from the nominal track up to the point (P) where the tangent becomes parallel to the nominal track after the turn.

3.3.5.2 The same principle applies for the area on the inner side of the turn, except that the 30° line from the nominal track is up to the point from whichever edge of the area provides the best lateral protection. See Figure I-2-3-6.

Table I-2-3-1. Turn construction parameter

Segment or fix of turn location	Speed (IAS)*	Altitude/height	Wind	Bank angle**	FTT (seconds)			
					c (seconds)		Outbound timing tolerance	Heading tolerance
					Bank establishment time	Pilot reaction time		
Departure	Final missed approach IAS + 10%, see Table I-4-1-1 or I-4-1-2 ³	Turn at altitude/height: Specified altitude/height Turn at turn point: A/D elevation + height based on 10% climb from DER	95% omni-directional wind or 56 km/h (30 kt) for wind spirals	For turn area calculation: 15° For establishment of the average flight path only: 15° until 305 m (1 000 ft) 20° between 305 m (1 000 ft) and 915 m (3 000 ft) 25° above 915 m (3 000 ft)	3	3	N/A	N/A
En-route	585 km/h (315 kts)	Specified altitude	95% probability wind, or ICAO standard wind ⁴	15°	5	10	N/A	N/A
Holding	Table II-4-1-1 ²	Specified altitude	ICAO standard wind ⁴	For conventional and RNAV except RNP: 25° For RNP: 23° for FL < 245 and 15° for FL > 245	5	6	10	5°
					N/A	N/A	N/A	
Initial approach – reversal and racetrack procedures	Table I-4-1-1 or I-4-1-2	Specified altitude	ICAO standard wind ⁴ or statistical wind	25°	5	6	10	5

Segment or fix of turn location	Speed (IAS)*	Altitude/height	Wind	Bank angle**	FTT (seconds)			
					c (seconds)		Outbound timing tolerance	Heading tolerance
					Bank establishment time	Pilot reaction time		
Initial approach – DR track procedures	CAT A, B – 165 to 335 km/h (90 to 180 kts) CAT C, D, E – 335 to 465 km/h (180 to 250 kts)	CAT A, B — 1 500m (5 000 ft) CAT C, D, E — 3 000 m (10 000 ft)	ICAO standard wind [†] DR leg; 56 km/h (30 kts)	25°	5	6	N/A	5
IAF, IF FAF	See Table I-4-1-1 and I-4-1-2 Use initial approach speed for turn at IAF or IF Use maximum final approach speed for turn at FAF.	Specified altitude	95% omni-directional wind or 56 km/h (30 kt)	25°	5	6	N/A	N/A
Missed approach	Table I-4-1-1 or I-4-1-2 ¹	A/D elevation + 300 m (1 000 ft)	56 km/h (30 kt)	15°	3	3	N/A	N/A
Visual manoeuvring using prescribed track	See Table I-4-1-1 and I-4-1-2	A/D elevation + 300 m (1 000 ft)	46 km/h (25 kt)	25°	N/A	N/A	N/A	N/A
Circling	See Table I-4-1-1 and I-4-1-2	A/D elevation + 300 m (1 000 ft)	46 km/h (25 kt)	20°	N/A	N/A	N/A	N/A

GENERAL NOTES: * For the specific application of the parameters in the table, see the applicable chapters.

** The rate of turn associated with the stated bank angle values in this table shall not be greater than 3° /s, except for visual manoeuvring using prescribed track.

Note 1.— Where operationally required to avoid obstacles, reduced speeds as slow as the IAS for intermediate missed approach may be used, provided the procedure is annotated “Missed approach turn limited to _____ km/h (kt) IAS maximum.”

Note 2.— The conversion from IAS to TAS is determined using a temperature equal to ISA at the corresponding altitude plus 15° C. Holding procedures are an exception; the calculation formula includes correction for compressibility and appears in Part II, Section 4, Appendix to Chapter 1.

Note 3.— Where operationally required to avoid obstacles, reduced speeds as slow as the IAS tabulated for “intermediate missed approach” in Tables I-4-1-1 and I-4-1-2 increased by 10 per cent may be used, provided the procedure is annotated “Departure turn limited to _____ km/h (kt) IAS maximum”. In order to verify the operational effect of a desired speed limitation, the speed value should be compared with the statistical speed as published in Section 3, Appendix to Chapter 3.

Note 4.— ICAO standard wind = 12 h + 87 km/h (h in 1 000 m), 2 h + 47 kts (h in 1 000 ft)

Table I-2-3-2. Example of calculations of various turning parameters for a selection of IAS (calculated for 600 m MSL) (for abbreviations, see 3.1.2, “Turn parameters”)

<i>IAS</i> (<i>km/h</i>)	<i>TAS</i> (<i>600 m, ISA + 15</i>) <i>IAS conversion</i> <i>factor*</i> (<i>km/h</i>)	<i>c</i> <i>6 seconds</i> (<i>TAS + 56</i>) <i>6</i> <i>3 600</i> (<i>km</i>)	<i>R</i> <i>542</i> <i>TAS</i> (<i>deg/s</i>)	<i>r</i> <i>TAS</i> <i>62.8R</i> (<i>km</i>)	<i>E</i> <i>1.4</i> <i>R</i> (<i>km</i>)
205	217	0.46	2.50	1.38	0.56
280	296	0.59	1.83	2.57	0.76
345	364	0.70	1.49	3.89	0.94
400	422	0.80	1.28	5.23	1.09
445	470	0.88	1.15	6.49	1.21
490	518	0.96	1.05	7.85	1.34
510	539	0.99	1.01	8.54	1.39

* For conversion from IAS to TAS, see the Appendix to Chapter 1.

Table I-2-3-3. Example of calculations of various turning parameters for a selection of IAS (calculated for 2 000 ft MSL) (for abbreviations, see 3.1.2, “Turn parameters”)

<i>IAS</i> (<i>kt</i>)	<i>TAS</i> (<i>2 000 ft, ISA + 15</i>) <i>IAS conversion</i> <i>factor*</i> (<i>kt</i>)	<i>c</i> <i>6 seconds</i> (<i>TAS + 30</i>) <i>6</i> <i>3 600</i> (<i>NM</i>)	<i>R</i> <i>293</i> <i>TAS</i> (<i>deg/s</i>)	<i>r</i> <i>TAS</i> <i>62.8R</i> (<i>NM</i>)	<i>E</i> <i>0.75</i> <i>R</i> (<i>NM</i>)
110	116	0.24	2.53	0.73	0.30
150	159	0.32	1.84	1.37	0.41
185	195	0.38	1.50	2.07	0.50
200	211	0.40	1.39	2.42	0.54
240	254	0.47	1.15	3.51	0.65
265	280	0.52	1.05	4.25	0.72
275	291	0.54	1.01	4.60	0.74

* For conversion from IAS to TAS, see the Appendix to Chapter 1.

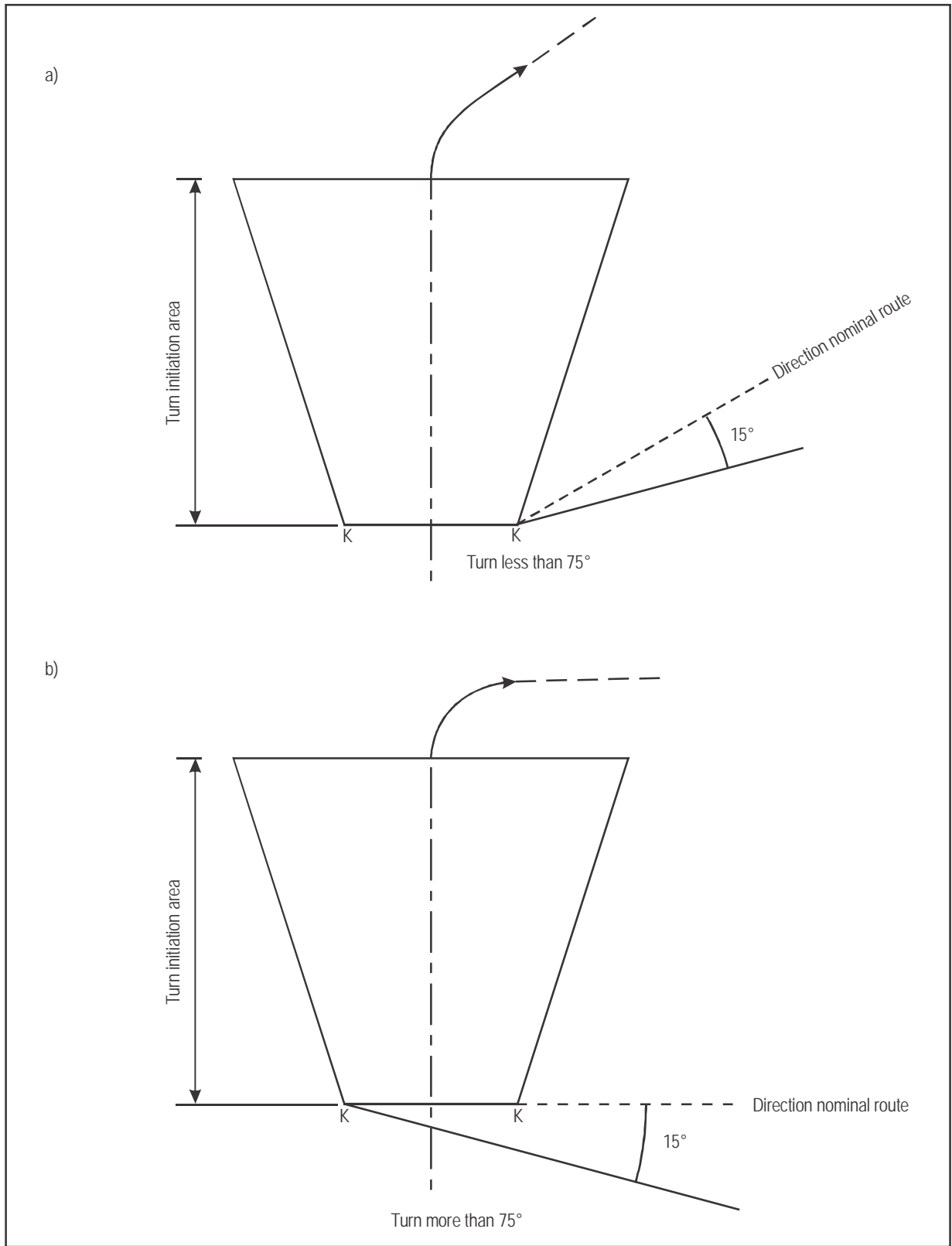

Figure I-2-3-1. Turn inner boundary protection

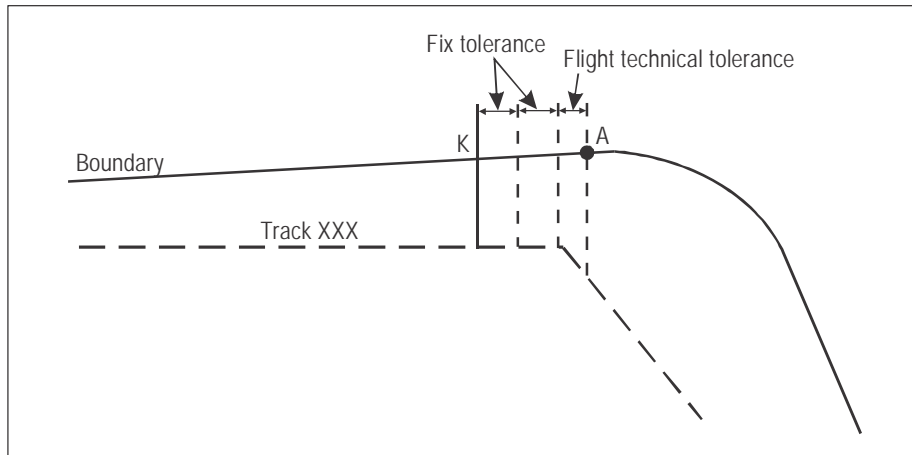

Figure I-2-3-2. Start of construction of outer boundary

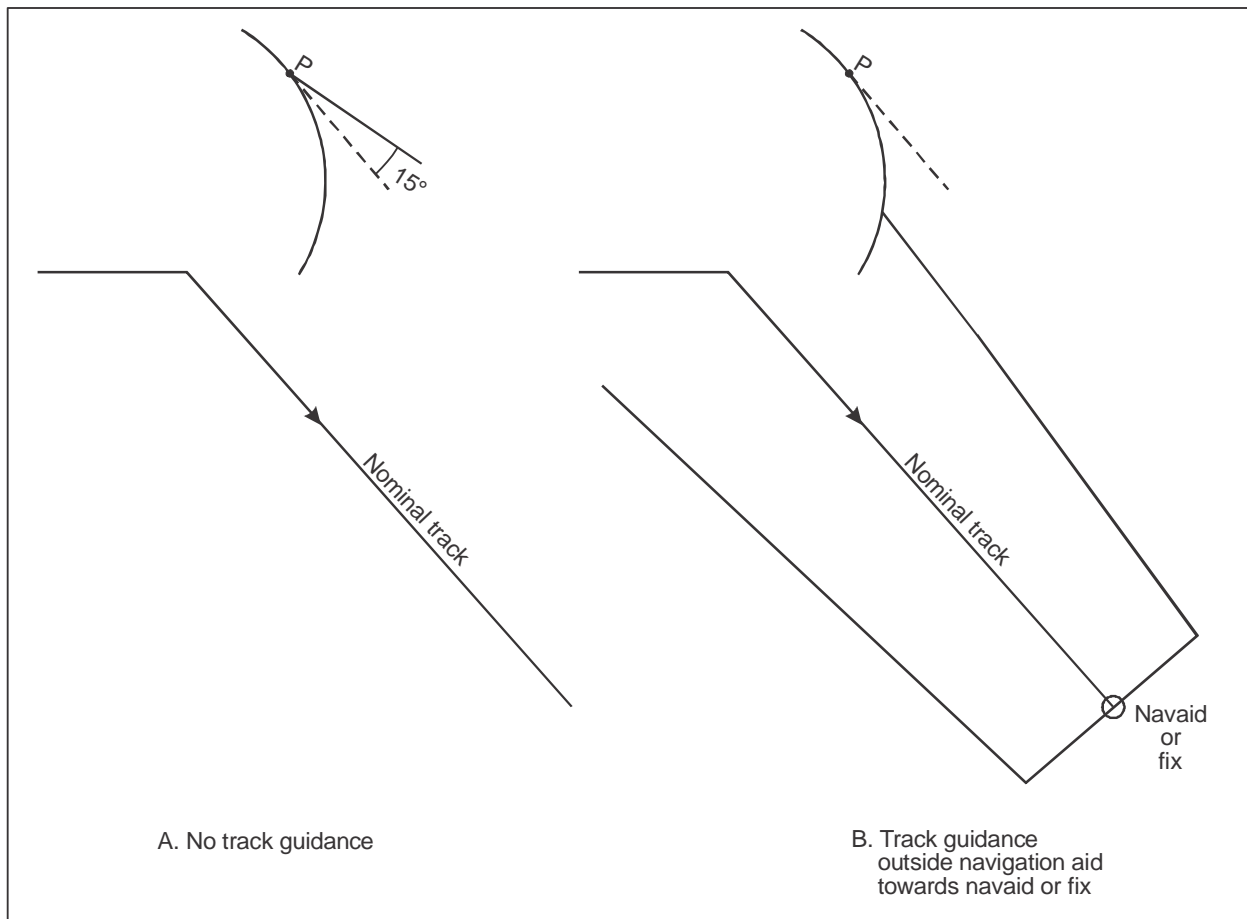
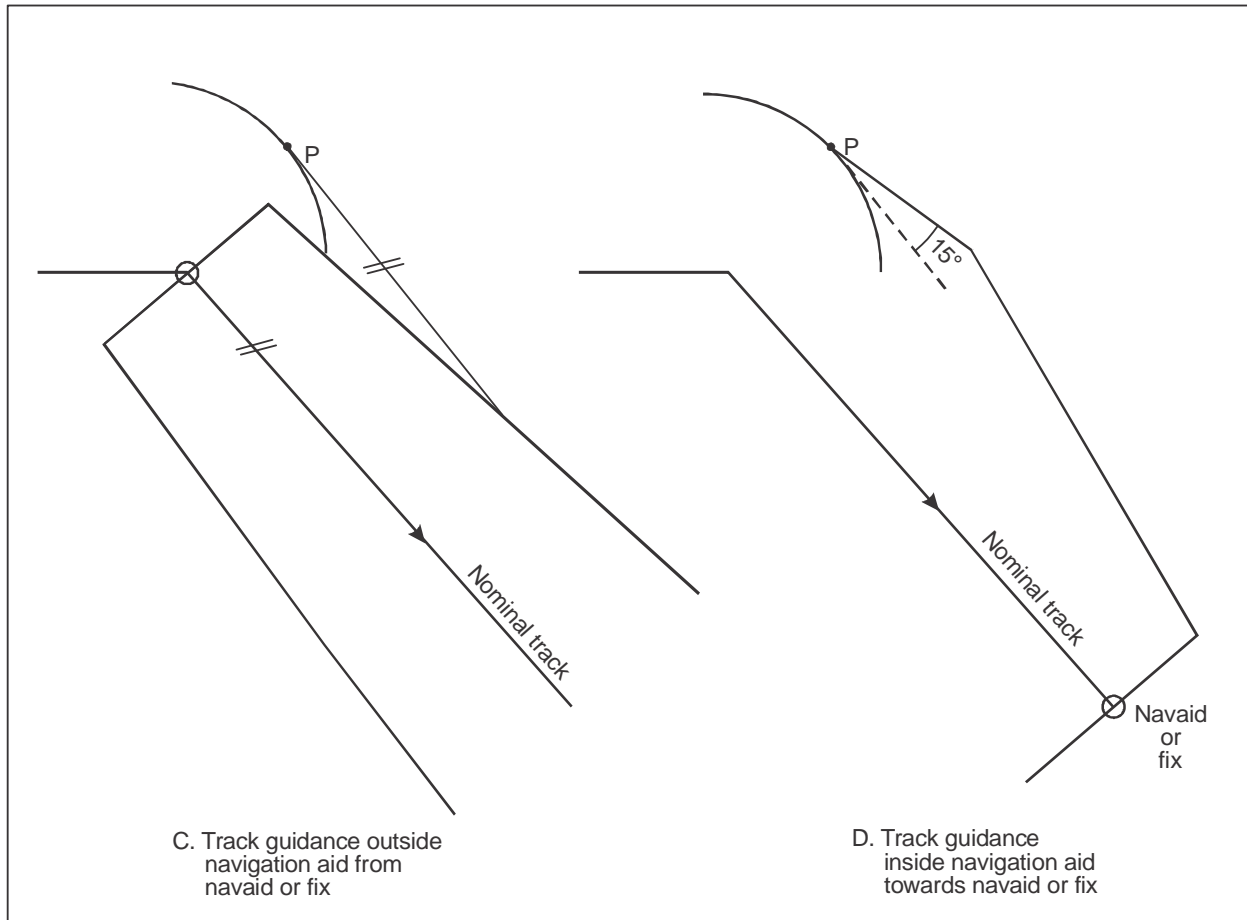

Figure I-2-3-3 a) and b). Turn outer boundary construction after Point P



**Figure I-2-3-3 c) and d). Track guidance outside navigation aid from navaid or fix/
Track guidance inside navigation aid or fix**

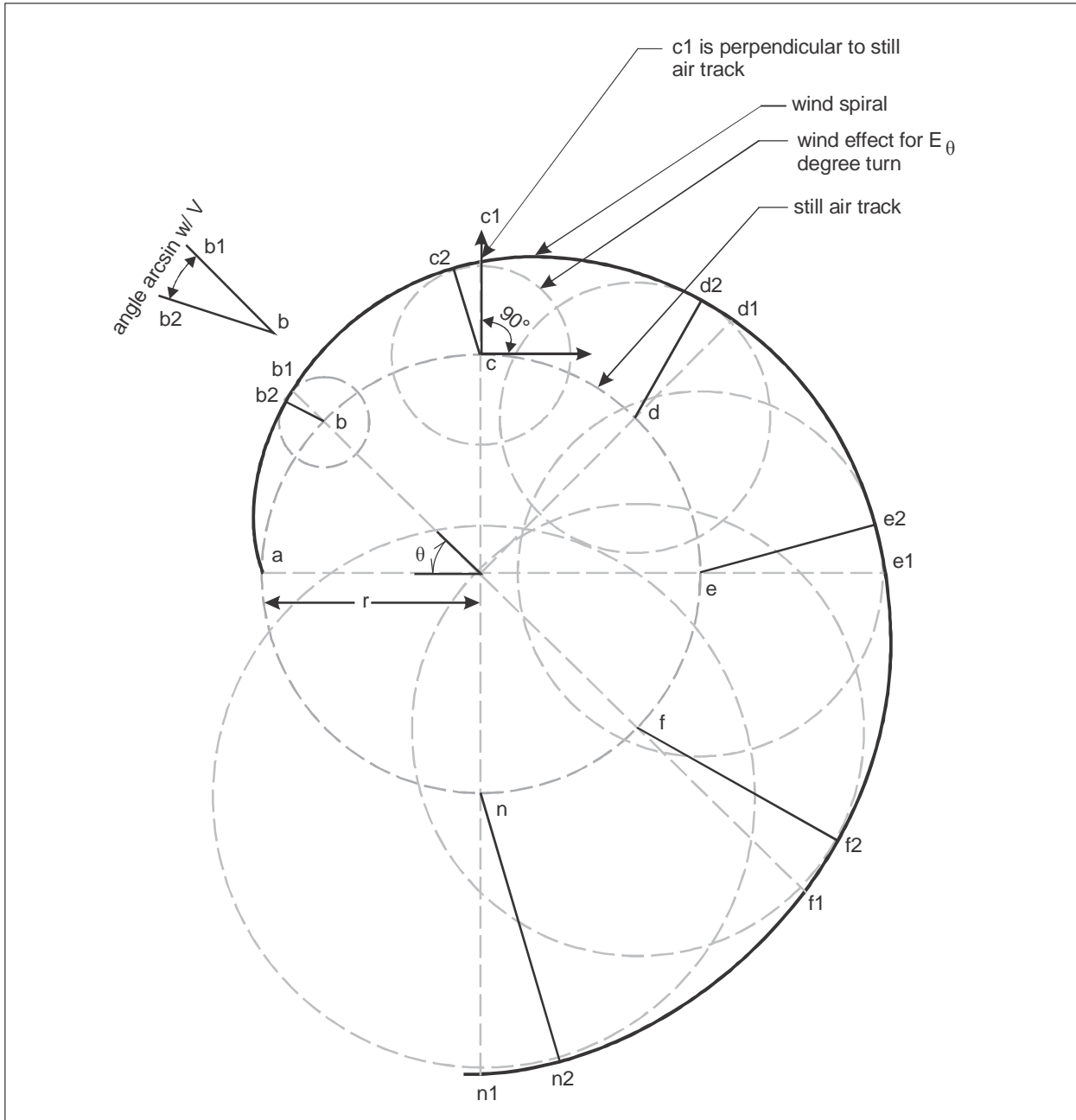

Figure I-2-3-4. Wind spiral

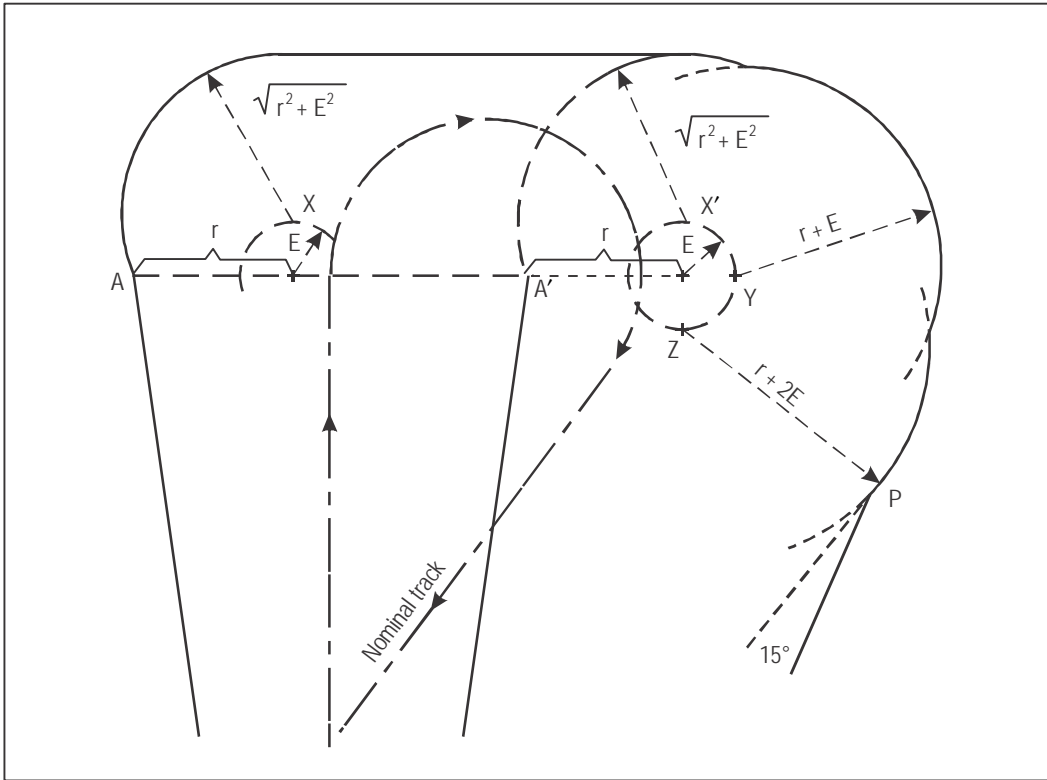

Figure I-2-3-5. Outer turn boundary construction

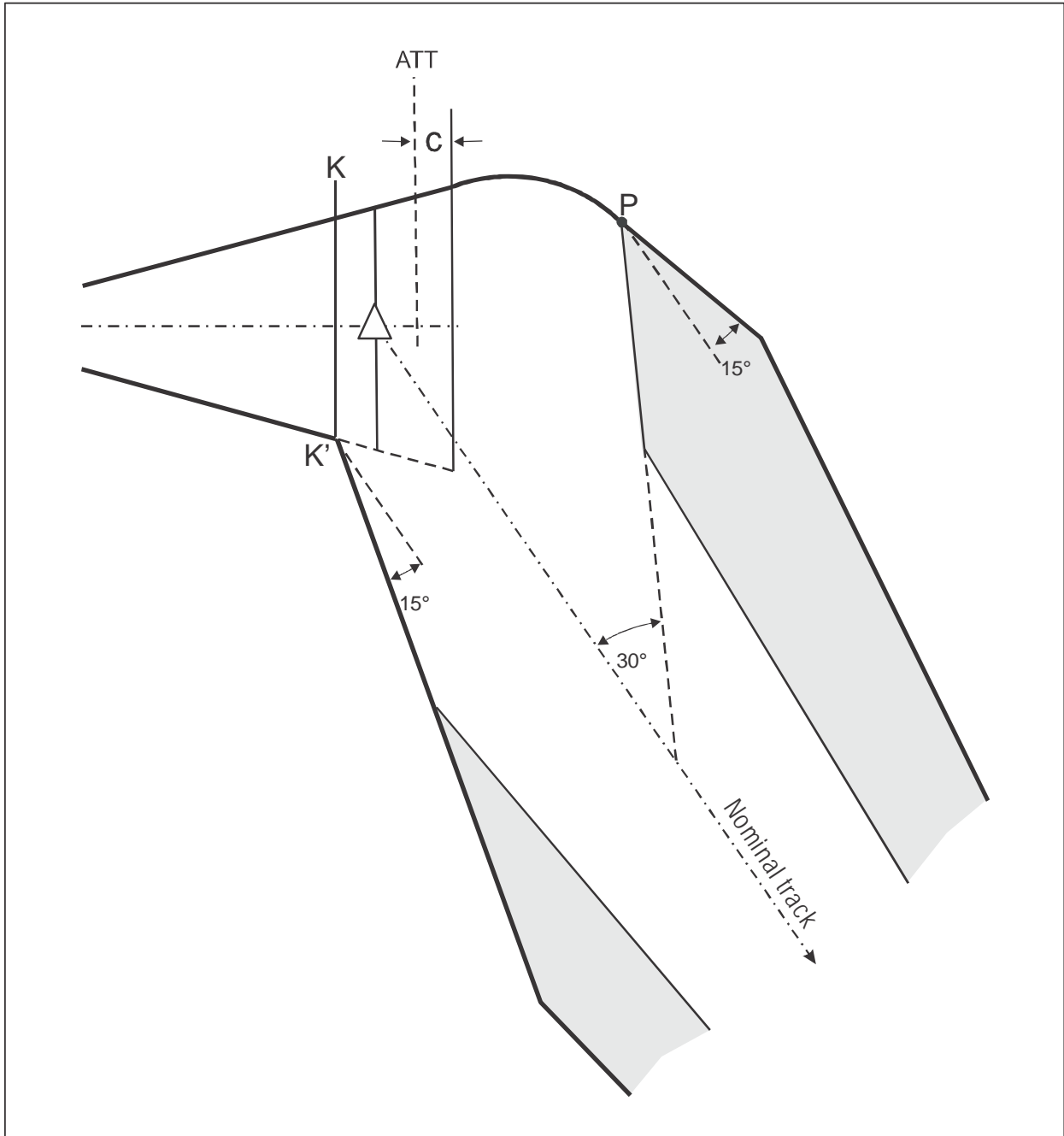

Figure I-2-3-6. Connection of secondary areas with additional track guidance

Chapter 4

QUALITY ASSURANCE

4.1 GENERAL

4.1.1 This chapter provides general provisions on quality assurance for the procedure design process. Detailed guidance can be found in the *Quality Assurance Manual for Flight Procedure Design* (Doc 9906).

4.1.2 The State is responsible to ensure that all published instrument flight procedures in their airspace can be flown safely by the relevant aircraft. Safety is not only accomplished by application of the technical criteria in PANS-OPS and associated ICAO provisions, but also requires measures that control the quality of the process used to apply that criteria, which may include regulation, air traffic monitoring, ground validation and flight validation. These measures shall ensure the quality and safety of the procedure design product through review, verification, coordination, and validation at appropriate points in the process, so that corrections can be made at the earliest opportunity in the process.

4.1.3 This chapter seeks to establish the framework for a quality process for procedure design, including inputs, key required elements, recommendations, and expected outputs.

4.1.4 In the interest of safety, and to promote a reasonable degree of standardization, it is desirable, to the greatest degree possible, to implement the provisions in PANS-OPS in a consistent manner, using processes that will minimize the possibility of errors, identify errors that do occur before they impact safety, and provide for continuous improvement of the procedure design process in order to eliminate or reduce future errors. This is especially important in the modern aviation environment, where increasing reliance is placed on computers and the data they process, for navigation and obstacle awareness.

4.1.5 The safety of air navigation is highly dependent on the quality of aeronautical data. Processes for data quality assurance, from data origination through to publication in the State's Aeronautical Information Publication (AIP), is detailed in the *Quality Assurance Manual for Flight Procedure Design* (Doc 9906).

4.2 THE INSTRUMENT FLIGHT PROCEDURE PROCESS

The Instrument Flight Procedure (IFP) process (see Figure I-2-4-1) encompasses the acquisition of data, design and promulgation of procedures. It starts with compilation and verification of the many inputs and ends with ground and/or flight validation of the finished product, and documentation for publication. The elements of the process encompass enablers, constraints, output, and post-publication feedback for the procedure under consideration. The IFP process should be followed both for original procedure designs and periodic reviews of existing IFPs.

4.3 PROCEDURE DESIGN INFORMATION ACQUISITION

The procedure design information shall be coordinated with all relevant stakeholders. As input for the procedure design process the following aspects need to be assessed:

- a) airport, navigation aid, obstacle, and terrain coordinate and elevation data, based on verified surveys and complying with ICAO Annex 11, 14 and 15 requirements;
- b) airspace requirements;
- c) user requirements: needs of Air Traffic Service provider and operators who will use this procedure;
- d) airport infrastructure such as runway classification, lighting, communications, runway markings, and availability of local altimeter setting;
- e) environmental considerations; and
- f) any other potential issue associated with the procedure.

4.4 PROCEDURE DESIGN

4.4.1 Procedures shall be designed according to State-approved criteria, taking into account all design inputs. Coordination with all concerned parties should continue throughout the procedure design and validation process to ensure that the procedure meets the needs of the user and the community.

4.4.2 Each new or revised procedure shall be verified by a qualified procedure designer other than the one who designed the procedure, to ensure compliance with applicable criteria.

4.4.3 Published procedures shall be subjected to a periodic review, including validation (4.6), to ensure that they continue to comply with changing criteria, to confirm continued adequate obstacle clearance and that they meet user requirements. The individual States shall establish the interval for periodic review of instrument flight procedures according to the needs of the State. The maximum interval for this review is five years.

4.5 PROCEDURE DESIGN DOCUMENTATION

4.5.1 The documentation provided by the procedure designer is divided into three categories and includes:

- a) documentation required for publication in the States' AIP in accordance with ICAO Annexes 4 and 15;
- b) documentation required to maintain transparency concerning the details and assumptions used by the procedure designer, which should include supporting information/data used in the design, such as:
 - 1) controlling obstacle for each segment of the procedure;
 - 2) effect of environmental considerations on the design of the procedure;
 - 3) infrastructure assessment;
 - 4) airspace constraints;
 - 5) the results of the periodic review and, for modifications or amendments to existing procedures, the reasons for any changes;
 - 6) for any deviation from existing standards, the reasons for such a deviation and details of the mitigations applied to assure continued safe operations; and

- 7) the results of the final verification for accuracy and completeness (quality assurance checks) prior to validation and then prior to publication;
- c) additional documentation required to facilitate ground and flight validation of the procedure and the results of the ground and flight validation.

4.5.2 All documentation should be retained in accordance with States' procedures to assist in recreating the procedure in the future in the case of incidents and for periodic review and maintenance. The period of retention shall not be less than the operational lifetime of the procedure.

4.6 GROUND AND FLIGHT VALIDATION

4.6.1 Validation

Validation is the necessary final quality assurance step in the procedure design process, prior to publication. The purpose of validation is the verification of all obstacle and navigation data, and assessment of flyability of the procedure. Validation normally consists of ground validation and flight validation. Ground validation shall always be undertaken. When the State can verify, by ground validation, the accuracy and completeness of all obstacle and navigation data considered in the procedure design, and any other factors normally considered in the flight validation (4.6.3), then the flight validation requirement may be dispensed with. The process for the validation of flight procedures is detailed in the *Quality Assurance Manual for Flight Procedure Design, Volume 5 — Validation of Instrument Flight Procedures* (Doc 9906).

4.6.2 Ground validation

Ground validation is a review of the entire instrument flight procedure package by a person(s) trained in procedure design and with appropriate knowledge of flight validation issues. It is meant to catch errors in criteria and documentation, and evaluate on the ground, to the extent possible, those elements that will be evaluated in a flight validation. Issues identified in the ground validation should be addressed prior to any flight validation. The ground validation will also determine if flight validation is needed for modifications and amendments to previously published procedures.

4.6.3 Flight validation

4.6.3.1 Flight validation of instrument flight procedures should be carried out as part of the initial certification and should also be included as part of the periodic quality assurance programme as established by the individual States to ensure that the procedure design process and its output, including the quality of aeronautical information/data, meet the requirements of Annex 15. It shall be accomplished by a qualified and experienced flight validation pilot, certified or approved by the State. The flight validation pilot shall occupy a seat in the cockpit with a field of view adequate to conduct the flight validation. The objectives of the flight validation of instrument flight procedures are to:

- a) provide assurance that adequate obstacle clearance has been provided;
- b) verify that the navigation data to be published, as well as that used in the design of the procedure, is correct;
- c) verify that all required infrastructure, such as runway markings, lighting, and communications and navigation sources, are in place and operative;
- d) conduct an assessment of flyability to determine that the procedure can be safely flown; and
- e) evaluate the charting, required infrastructure, visibility and other operational factors.

4.6.3.2 Flight validation should not be confused with flight inspection. Flight inspection of instrument flight procedures is required to assure that the appropriate radio navigation aids adequately support the procedure. This is carried out as part of a formal flight inspection programme and is performed by a qualified flight inspector using an appropriately equipped aircraft.

4.6.4 The procedure designer shall be the originator of all data applicable to conducting a flight validation provided to the flight validation or flight inspection operations activity. The procedure designer should be prepared to provide briefings to the flight validation or flight inspection crews in those cases where flight procedures have unique application or special features.

4.6.5 The procedure designer may participate in the initial validation flight to assist in its evaluation and obtain direct knowledge of issues related to the procedure's design from the flight inspection or validation pilot and/or inspector.

4.6.6 Flight validation pilot qualifications and training

4.6.6.1 The State shall establish a written policy requiring minimum qualifications, recency of experience, training and competency level standards for flight validation pilots, including those flight inspection pilots who perform flight validation of instrument flight procedures. Flight validation pilot qualifications shall include at least a commercial pilot licence with instrument rating, or an equivalent authorization from the State meeting the Annex 1 knowledge and skill requirements for issue of the commercial pilot licence and instrument rating, in the aircraft category (e.g. aeroplane or helicopter) appropriate for the procedure to be validated. In addition, flight validation pilots shall meet all the experience requirements for the airline transport pilot licence in the relevant category of aircraft (e.g. aeroplane or helicopter) as defined in Annex 1. If the flight validation pilot is not the pilot-in-command of the flight validation aircraft, then the provisions of this paragraph also apply to the pilot-in-command of the flight validation aircraft.

Note.— The provisions of Annex 1, 2.6.3.1.2 or 2.6.4.1.2, may be applicable with regard to meeting the experience requirements for the airline transport pilot licence.

4.6.6.2 In order to achieve the safety and quality assurance objectives of the flight validation, each State shall ensure that flight validation pilots have acquired and maintain the required competency level through training and supervised on-the-job training.

Note.— Recommended qualifications and training, as well as guidance concerning the skills, knowledge and attitudes to be addressed in the training and evaluation of flight validation pilots can be found in Appendix B of Volume 1 (Flight Procedure Design Quality Assurance System) of the Quality Assurance Manual for Flight Procedure Design (Doc 9906).

4.6.7 Additional detailed information and guidance concerning flight inspection, as well as qualifications and certification of flight inspectors, can be found in the ICAO *Manual on Testing of Radio Navigation Aids*, Volumes I, II, and III (Doc 8071).

4.7 PROCEDURE DESIGNER QUALIFICATIONS AND TRAINING

4.7.1 Each State shall establish standards for the required competency level for flight procedure design. Each State shall ensure that flight procedure designers have acquired and maintain this competency level through training and supervised on-the-job training (OJT). This is to ensure that the quality assurance in the procedure design process and its output, including the quality of aeronautical information/data, meets the requirements of Annex 15 — *Aeronautical Information Services*.

4.7.2 Training for flight procedure design should at least include an initial training and recurrent training at periodic intervals. The State should establish the appropriate interval for recurrent training.

4.7.3 Initial training shall ensure that the flight procedure designer is able to demonstrate a basic level of competency that includes at least the following elements:

- a) knowledge of information contained in the PANS-OPS, Volumes I and II and other related ICAO provisions relevant to the State; and
- b) skills in the design of procedures.

4.7.4 Recurrent training shall ensure that the flight procedure designer is able to demonstrate a basic level of competency that includes at least the following elements:

- a) knowledge about updates in ICAO provisions and other provisions pertaining to procedure design; and
- b) maintenance and enhancement of knowledge and skills in the design of procedures.

4.7.5 The State shall ensure that flight procedure designers have undergone an adequate, supervised OJT.

4.7.6 Competency of the flight procedure designer shall be evaluated by the State at regular intervals.

4.7.7 Guidance material for planning, implementing and evaluating flight procedure designer training is provided in the *Quality Assurance Manual for Flight Procedure Design, Volume 2 — Flight Procedure Designer Training* (Doc 9906).

4.8 PROCEDURE DESIGN AUTOMATION

4.8.1 Procedure design automation tools have the potential to greatly reduce errors in the procedure design process, as well as to standardize the application of the PANS-OPS criteria. For this reason States should use the available software packages to design their instrument flight procedures.

4.8.2 ICAO produces several tools automating elementary portions of the procedure design criteria, where the consequences of error are particularly significant to safety. Included in these tools are the PANS-OPS OAS Software and the PANS-OPS Software (CD-101), providing a means to evaluate the total risk of impact with an obstacle or the ground on precision approaches.

4.8.3 There are numerous other software packages available that automate, to varying degrees, the application of PANS-OPS criteria to the procedure design. The advantages are many, including maintaining the integrity of the source data throughout the design phase, reducing human errors, gaining the capability to develop “what-if” scenarios, and standardized application of the criteria. While software developers test their software extensively, there is no absolute guarantee as to the accuracy of any individual application of the criteria.

4.8.4 As States are responsible for the safety of instrument flight procedures, they should ensure that the software packages used in the design of procedures have been validated. The *Quality Assurance Manual for Flight Procedure Design, Volume 3 — Flight Procedure Design Software Validation* (Doc 9906) provides guidance to assist States in this task.

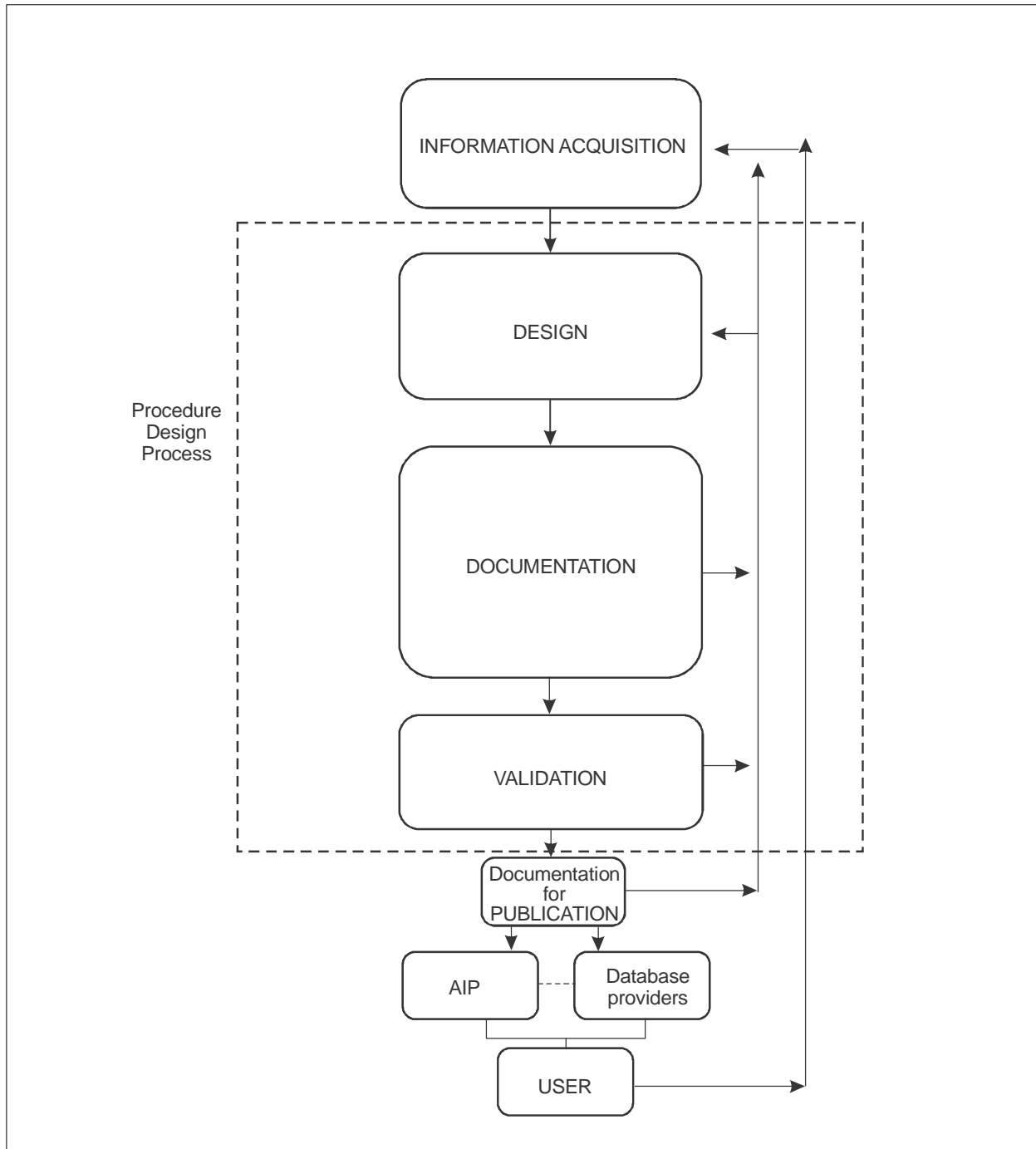

Figure I-2-4-1. Instrument flight procedure process

Section 3

DEPARTURE PROCEDURES

Chapter 1

INTRODUCTION TO DEPARTURE PROCEDURES

1.1 GENERAL

A departure procedure designed in accordance with this section provides obstacle clearance immediately after take-off until the aircraft intercepts an en-route segment. Departure procedures include, but are not limited to, standard departure routes and associated procedures (Annex 11, Appendix 3).

1.2 CONSULTATION

A departure procedure may also be required for air traffic control, airspace management or other reasons (e.g. noise abatement) and the departure route or procedure may not be determined by obstacle clearance requirements alone. Departure procedures should be developed in consultation with the operators, ATC and other parties concerned. (See Volume I, Part I, Section 7 for noise abatement considerations.)

1.3 STANDARDIZATION

The specifications contained in this section are based on conventional navigation equipment and operating practices and have been formulated with a view to achieving a reasonable degree of standardization. Exceptions should be permitted only after joint consideration by the State authority and the operators concerned. For RNAV departures, refer also to the requirements in Part III.

1.4 ECONOMY

In the interest of efficiency and economy, every effort should be made to ensure that procedures are designed, consistent with safety, to minimize both the time taken in executing a departure and the airspace required.

1.5 ROUTES

Departure procedures may be published as specific routes (see Chapter 3) or as omnidirectional departures (see Chapter 4).

1.6 RELATED MATERIAL

For the construction of obstacle clearance areas associated with turns, reference should be made to the standard techniques contained in Section 2, Chapter 3, “Turn area construction”. Navigation aid characteristics and fix tolerances are specified in Section 2, Chapter 2, “Terminal area fixes”.

1.7 ABNORMAL AND EMERGENCY OPERATIONS

1.7.1 The design of procedures in accordance with this section assumes normal operations and that all engines are operating.

1.7.2 It is the responsibility of the operator to conduct an examination of all relevant obstacles and to ensure that the performance requirements of Annex 6 are met by the provision of contingency procedures for abnormal and emergency operations. Where terrain and/or obstacle considerations permit, the contingency procedure routing should follow that of the departure procedure.

1.7.3 It is the responsibility of the State to make available the obstacle information described in Annexes 4 and 6, and any additional information used in the design of departures in accordance with this Section.

Chapter 2

GENERAL CONCEPTS FOR DEPARTURE PROCEDURES

2.1 ESTABLISHMENT OF A DEPARTURE PROCEDURE

2.1.1 For each runway at aerodromes where instrument departures are expected to be used, a departure procedure shall be established and promulgated.

2.1.2 A departure procedure should be designed to accommodate all aircraft categories where possible. Where departures are limited to specific categories, the departure chart shall clearly identify the applicable categories. (See Section 4, Chapter 1, 1.8.7, “Restrictions on category and IAS”).

2.2 DESIGN PRINCIPLES

2.2.1 Departures may be designed as straight departures or turning departures (see Chapter 3). Procedure design should consider the environmental and efficiency advantages afforded by implementation of a continuous climb operation (CCO).

Note.— The *Continuous Climb Operations (CCO) Manual (Doc 9993)* provides guidance on implementing CCO and balancing CCO within the context of other ATM operations.

2.2.2 An omnidirectional departure procedure may be designed that permits a turn in any direction after reaching a specified altitude/height (see Chapter 4).

2.2.3 A straight departure may permit a turn of 15° or less.

2.2.4 An aircraft will maintain the runway direction until reaching a minimum height of 120 m (394 ft) (Cat H, 90 m (295 ft)) above the runway/FATO before commencing a turn.

2.2.5 A turning departure will specify a turn either at a turn point or an altitude/height.

2.2.6 The standard procedure design gradient (PDG) is 3.3 per cent (Cat H, 5.0 per cent). The PDG begins at a point 5 m (16 ft) above the departure end of the runway (DER).

2.2.7 The standard PDG provides an additional clearance of 0.8 per cent of the distance flown from the DER, above an obstacle identification surface (OIS). The OIS has a gradient of 2.5 per cent (Cat H, 4.2 per cent).

2.2.8 Where an obstacle penetrates the OIS, a steeper PDG may be promulgated to provide obstacle clearance of 0.8 per cent of the distance flown from the DER.

2.2.9 Before any turn greater than 15 degrees may be executed, a minimum obstacle clearance of 75 m (246 ft) (CAT H, 65 m (213 ft)) must be reached. Alternatively, 0.8 per cent of the distance from the DER may be used, if this value is higher. This minimum obstacle clearance must be maintained during subsequent flight.

2.3 BEGINNING OF THE DEPARTURE PROCEDURE

2.3.1 Aeroplanes

2.3.1.1 For aeroplanes the departure procedure begins at the departure end of the runway (DER), which is the end of the area declared suitable for take-off (i.e. the end of the runway or, where a clearway is provided, the end of the clearway).

2.3.1.2 Since the point of lift-off will vary, and in order to protect for turns prior to the DER, the protected area begins at a point 600 m from the start of runway. This is based on the assumption that the minimum turn height of 120 m (394 ft) above the elevation of the DER could be reached 600 m from the start of runway.

Note.— The elevation of the DER is the elevation of the end of the runway or the elevation of the end of the clearway, whichever is higher.

2.3.2 Helicopters

2.3.2.1 For helicopters, the departure procedure begins at the departure end of the runway (DER). The DER is the end of the area declared suitable for take-off (i.e. end of the runway or clearway or the end of the final approach and take-off (FATO) area).

2.3.2.2 To account for the climb performance of helicopters, and to protect for early turns, the protected area commences at the beginning of the runway or area available for take-off based on the assumption that the minimum turn height of 90 m (295 ft) above the elevation of the DER could be reached overhead the start of take-off (see Figure I-3-2-1).

Note.— The elevation of the DER is the higher of the elevations of the beginning and end of the runway/FATO.

2.4 END OF THE DEPARTURE PROCEDURE

The departure procedure ends at the point where the route connects to the next segment and the PDG reaches the minimum altitude/height authorized for the next phase of flight (i.e. en-route, holding or approach).

2.5 MINIMUM OBSTACLE CLEARANCE (MOC)

2.5.1 The minimum obstacle clearance (MOC) in the primary area is 0.8 per cent of the distance flown from the DER. The MOC is zero at the DER.

2.5.2 The MOC is provided above an obstacle identification surface or, where an obstacle penetrates the OIS, above the elevation of the obstacle.

2.5.3 In addition to the above prior to the commencement of a turn of more than 15 degrees, MOC of 75 m (246 ft) (CAT H, 65 m (213 ft)) is required.

2.5.4 Where mountainous terrain is a factor, consideration shall be given to increasing the minimum obstacle clearance (see Section 2, Chapter 1, 1.7, “Increased altitudes/heights for mountainous areas”).

2.6 OBSTACLE IDENTIFICATION SURFACE (OIS)

2.6.1 The obstacle identification surface (OIS) is a sloping surface used to identify obstacles in the departure area. For straight departures the origin of the OIS is 5 m (16 ft) above the DER. For omnidirectional departures several OIS are considered as described in Chapter 4, “Omnidirectional Departures.” The OIS gradient is 2.5 per cent (Cat H, 4.2 per cent).

2.6.2 Survey of OIS

2.6.2.1 The OIS should be surveyed at regular intervals to validate obstacle information so that the minimum obstacle clearance is assured and the integrity of departure procedures is safeguarded. The competent authority should be notified whenever an object is erected that penetrates the OIS.

Note.— Yearly checks are considered to meet the requirement for “regular intervals.”

2.6.2.2 Distances to obstacles should be referenced to the DER.

2.7 PROCEDURE DESIGN GRADIENT (PDG)

2.7.1 The procedure design gradient (PDG) is the published climb gradient measured from the origin of the OIS (5 m (16 ft) above DER). Provided no obstacles penetrate the OIS the procedure design gradient (PDG) is the OIS gradient plus 0.8 per cent. (3.3 per cent, Cat H 4.2 per cent).

2.7.2 Where the 2.5 per cent OIS is penetrated, the departure route should be adjusted to avoid the penetration. If this is not possible then the PDG may be increased to provide the minimum obstacle clearance above the penetration (0.8 per cent of the distance from the DER). (See Figure I-3-2-2.)

2.7.3 A PDG in excess of 3.3 per cent and the altitude to which the increased gradient extends shall be promulgated.

2.7.4 Where the PDG is increased to avoid a penetrating obstacle, the PDG shall be reduced to 3.3 per cent at the point past the critical obstacle where obstacle clearance of 0.8 per cent of the distance from the DER can be provided. (See Figure I-3-2-2.)

2.7.5 An increased gradient that is required to a height of 60 m (200 ft) or less, (normally due to low, close-in obstacles) shall not be promulgated (see Figure I-3-2-3). The position and elevation/height of close-in obstacles penetrating the OIS shall be promulgated (see Chapter 5, “Published information for departure procedures”).

2.8 AVERAGE FLIGHT PATH

2.8.1 When close conformance to the nominal track is important (for noise abatement/ATC constraints, etc.), actual flight track data may be used to determine the average flight path.

2.8.2 Guidance material (based on statistical data) on how to establish an average flight path is given in Chapter 3, Appendix. The aircraft performance used to determine the average flight path must not be used for obstacle clearance calculation purposes.

2.9 CHARTING ACCURACY

Charting accuracy must be taken into account by applying vertical and horizontal tolerances, as described in Section 2, Chapter 1, 1.9, “Charting accuracy”. When the application of these tolerances creates an unacceptable operational penalty, additional survey information should be used to refine the obstacle location and height data.

2.10 ADDITIONAL SPECIFIC HEIGHT/DISTANCE INFORMATION

Whenever a suitably located DME exists, or when suitably located RNAV fixes can be established, additional specific height/distance information intended for obstacle avoidance should be published in order to provide a means of monitoring aircraft position relative to critical obstacles.

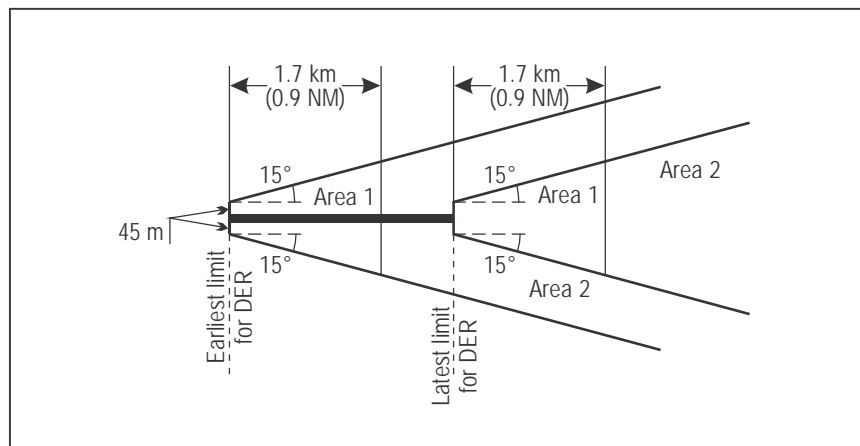

Figure I-3-2-1. Beginning of the departure procedure — helicopters

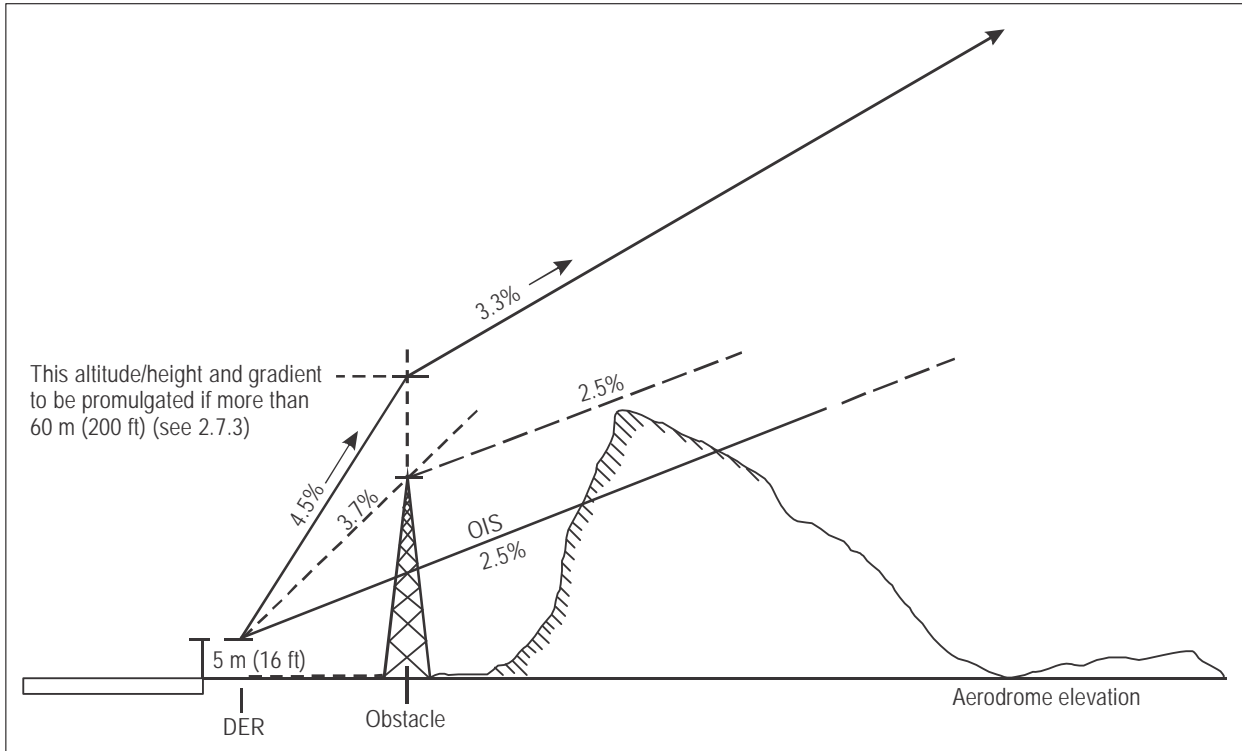

Figure I-3-2-2. Procedure design gradient

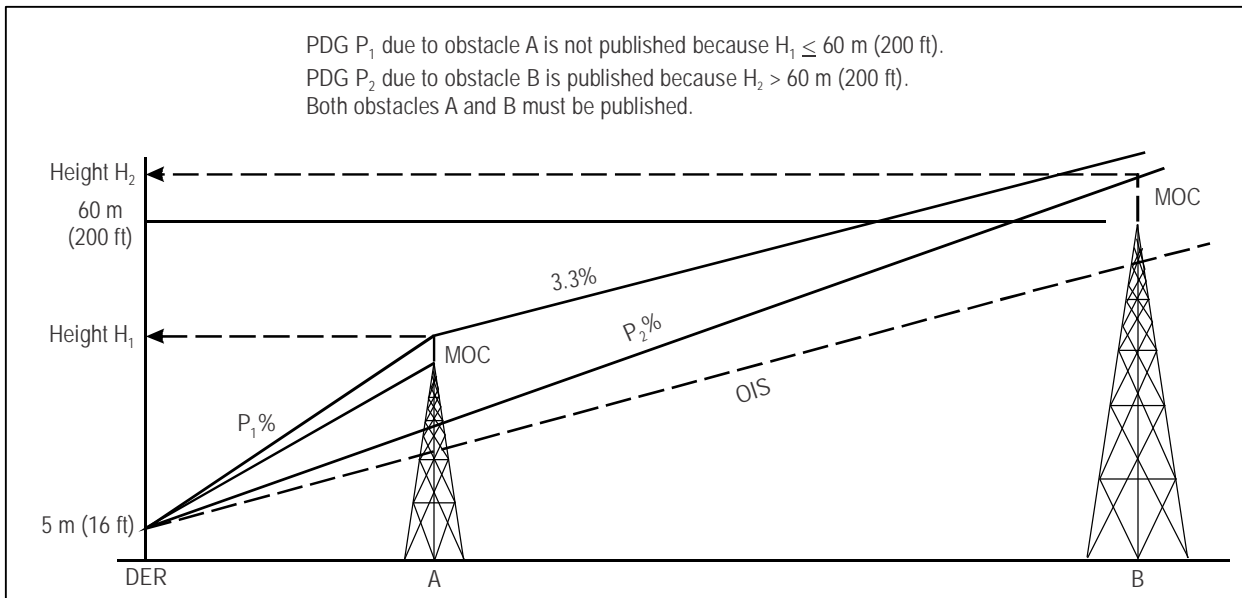

Figure I-3-2-3. Close-in obstacles

Chapter 3

DEPARTURE ROUTES

3.1 GENERAL

3.1.1 There are two basic types of departure route: straight and turning.

3.1.2 Track guidance shall be provided:

- a) within 20.0 km (10.8 NM) from the departure end of the runway (DER) for straight departures; and
- b) within 10.0 km (5.4 NM) after completion of turns for turning departures.

3.1.3 Surveillance radar may be used to provide track guidance.

3.2 STRAIGHT DEPARTURES

3.2.1 General

3.2.1.1 A departure in which the initial departure track is within 15° of the alignment of the runway centre line is a straight departure. Wherever practical, the departure track should be the extended runway centre line (see Figure I-3-3-1).

3.2.1.2 For helicopters, the departure track must intersect the runway centre line within 1.7 km (0.9 NM) from the DER, or the departure track must be within 90 m laterally from the runway centre line at the DER.

3.2.2 Types of straight departure

Straight departures are divided into two main categories, depending upon the availability of initial track guidance:

- a) straight departure without track guidance:
 - 1) departure with no track adjustment;
 - 2) departure with track adjustment (track adjustment point not specified); and
 - 3) departure with track adjustment (track adjustment point specified); and

- b) straight departure with track guidance:
 - 1) facility ahead or behind; and
 - 2) offset (track parallel/track offset/track crossing).

3.2.3 Track adjustment

In the construction of areas it is assumed that any track adjustments will take place no further along the track than a point at which the PDG reaches 120 m (394 ft) (Cat H, 90 m (295 ft)) above the elevation of the DER, or at a specified track adjustment point.

3.2.4 Straight departure without track guidance

3.2.4.1 *Departure with no track adjustment*

The area begins at the DER and has an initial width of 300 m (Cat H, 90 m). It is centred on the runway centre line and splays at an angle of 15° on each side of the extended runway center line (see Figure I-3-3-1). The area terminates at the end of the departure procedure as specified in Chapter 2, 2.4, “End of the departure procedure.”

3.2.4.2 *Departure with track adjustment*

3.2.4.2.1 The initial departure track may be adjusted by 15° or less. When adjusted, the splay of the area boundary on the side of the track adjustment is increased by the track adjustment angle, starting at the DER.

3.2.4.2.2 On the side opposite the track adjustment, the boundary is adjusted by the same amount at a point where the PDG reaches 120 m (394 ft) (Cat H, 90 m (295 ft)). This distance is nominally 3.5 km/1.9 NM (Cat H, 1.7 km/0.9 NM) from the DER for a 3.3 per cent PDG (Cat H, 5.0 per cent) (see Figure I-3-3-2).

3.2.4.2.3 *Track adjustment point specified.* If a track adjustment point is specified (see Figure I-3-3-3):

- a) the splay of the area boundary on the side of the track adjustment is increased by the track adjustment angle, from the earliest tolerance of the track adjustment point; and
- b) the splay of the area boundary on the side opposite the track adjustment is reduced by the track adjustment angle from the latest tolerance of the track adjustment point.

3.2.5 Straight departure with track guidance

3.2.5.1 *General*

The area is constructed as described in 3.2.4, “Straight departure without track guidance” and extended to the point where the boundaries intercept the area associated with the navigation aid providing the track guidance (see Figures I-3-3-4 to I-3-3-8).

3.2.5.2 Areas associated with a navigation aid

The areas associated with a navigation aid other than a localizer consist of appropriate portions of the trapezoids specified in Part II, Section 2, Chapters 4 and 6. The general principle of secondary areas is applied.

3.3 TURNING DEPARTURES

3.3.1 General

3.3.1.1 A departure incorporating a turn of more than 15° is a turning departure. Turns may be specified at an altitude/height, or at a fix or at a facility.

3.3.1.2 Straight flight is assumed until reaching a height of at least 120 m (394 ft) (Cat H, 90 m (295 ft)) above the elevation of the DER. No provision is made for turning departures which require a turn below 120 m (394 ft) (Cat H, 90 m (295 ft)) above the elevation of the DER. Where the location and/or height of obstacles makes it impossible to construct turning departures which satisfy the minimum turn height criterion, departure procedures should be developed on a local basis in consultation with the operators concerned.

3.3.1.3 The areas considered in the design of turning departures are defined as:

- a) the turn initiation area; and
- b) the turn area.

The turn initiation area is an area within which the aircraft conducts a straight climb in order to reach the MOC required prior to the beginning of a turn 75 m (246 ft) (CAT H, 65 m (213 ft)). The turn area is the area in which the aircraft is considered to be turning.

3.3.2 Turn initiation area

3.3.2.1 For aeroplanes, the turn initiation area starts at a point 600 m from the start of runway. For helicopters the turn initiation area starts at the beginning of the area available for runway or the start of runway. From the start of the turn initiation area to the DER, the area is 300 m wide (Cat H, 90 m).

3.3.2.2 Where the departure chart prohibits turns prior to the DER the turn initiation area starts at the DER. For helicopters, an earliest limit for a turning departure may be located at an appropriate position along the runway/FATO.

3.3.2.3 The turn initiation area terminates at the TP. The TP may be defined by:

- a) the earliest fix tolerance of the TP fix (turn at designated turn point); or
- b) the position at which the PDG reaches the specified turn altitude/height.

3.3.2.4 The TP may be located no closer to the DER than the distance required at the PDG to reach the higher of 120 m (394 ft) (Cat H, 90 m (295 ft)) or the specified turn altitude/height. The turn initiation area is identical to the area associated with a straight departure with no track guidance as described in 3.2.4, “Straight departure without track guidance.”

(See Figures I-3-3-9 and I-3-3-10.)

3.3.3 Turn area

The turn area is constructed in the same manner as the turning missed approach area (see Section 4, Chapter 6, 6.4, “Turning missed approach”). The inner and outer boundaries of the turn area are constructed as specified in 3.2, “Turn inner boundary construction” and 3.3, “Turn outer boundary construction” in Section 2, Chapter 3, “Turn area construction”.

3.3.4 Turn parameters

The parameters on which turn areas are based are:

- a) altitude:
 - 1) *turn designated at an altitude/height*: turn altitude/height;
 - 2) *turn at a designated turning point*: aerodrome elevation plus 10 per cent of the distance from the DER to the TP (i.e. allowing for a 10 per cent climb);
- b) temperature: ISA + 15°C corresponding to a) above;
- c) *indicated airspeed*: the speed tabulated for “final missed approach” in Section 4, Chapter 1, Tables I-4-1-1 and I-4-1-2 for the applicable aircraft category, increased by 10 per cent to account for increased aircraft mass at departure. However, where operationally required to avoid obstacles, reduced speeds not less than 1.1 times the IAS tabulated for “intermediate missed approach” in Section 4, Chapter 1, Tables I-4-1-1 and I-4-1-2 may be used, provided the procedure is annotated “Departure turn limited to _____ km/h (kt) IAS maximum”. In order to verify the operational effect of a speed limitation, the speed should be compared with the statistical speed as published in the Appendix to Chapter 3.
- d) *true airspeed*: the IAS in c) above adjusted for altitude a) and temperature b);
- e) *wind*: maximum 95 per cent probability wind on an omnidirectional basis, where statistical wind data are available. Where no wind data are available, an omnidirectional 56 km/h (30 kt) wind should be used;
- f) *bank angle*: 15° average achieved;
- g) *fix tolerance*: as appropriate for the type of fix;
- h) *flight technical tolerances*: a distance equivalent to 6 seconds of flight (3 second pilot reaction and 3 second bank establishing time) at the specified speed. (See c) above. This value is represented by the letter c in this chapter); and
- i) *secondary areas*: secondary areas are applied where track guidance is available.

3.3.5 Turn at a specified altitude/height

3.3.5.1 General

A turn may be prescribed upon reaching a specified altitude/height to accommodate the situation where there is:

- a) an obstacle located in the direction of the straight departure that must be avoided; and/or
- b) an obstacle located abeam the straight departure track that must be overflown after the turn.

3.3.5.2 Turning altitude or height calculations

A turn altitude/height is selected which results in a turning point that ensures that the aircraft avoids the straight ahead obstacle or overflies the abeam obstacle with the required MOC. Turn height (TNH) is computed by:

$$\text{TNH} = d_r \text{PDG} + 5 \text{ m (16 ft)}$$

where: d_r is the horizontal distance from DER to the TP; and

PDG is the procedure design gradient.

3.3.5.3 Obstacle clearance calculation

a) *Turn initiation area.* The minimum obstacle clearance in the turn initiation area is calculated using the horizontal distance from the DER measured along the nominal track, at the design PDG. (See Chapter 2, 2.5, “Minimum obstacle clearance”.) Note that a turn may be commenced at the specified turn altitude, and that normal aircraft performance will often result in this altitude being reached before the end of the turn initiation area (TP). Therefore, the minimum obstacle clearance for turning must also be provided above all obstacles in the turn initiation area. This criterion will be met if the maximum obstacle elevation in the turn initiation area is:

- 1) maximum obstacle elevation/height = TNA/H – 75 m (246 ft) for aeroplanes; and
- 2) maximum obstacle elevation/height = TNA/H – 65 m (213 ft) for helicopters.

b) *Turn area.* The minimum obstacle clearance in the turn area is calculated as follows:

- 1) *Obstacles located before the TP (K-line).* MOC is the greater of the minimum MOC for turning 75 m (246 ft) (CAT H, 65 m (213 ft)) and $0.008 (d_r^* + d_o)$ where:

d_r^* is the distance measured along the departure track corresponding to the point on the turn initiation area boundary where the distance d_o is measured, and

d_o is the shortest distance from the turn initiation area boundary to the obstacle.

- 2) *Obstacles located after the TP (K-line).* MOC is the greater of the minimum MOC for turning 75 m (246 ft) (CAT H, 65 m (213 ft)), and $0.008 (d_r + d_o)$ where:

d_r is the horizontal distance from DER to the K-line, and

d_o is the shortest distance from the turn initiation area boundary to the obstacle.

See Figures I-3-3-9 and I-3-3-10.

The maximum permissible elevation/height of an obstacle in the turn area can be computed by:

$$\text{Maximum obstacle elevation/height} = \text{TNA/H} + d_o \text{PDG} - \text{MOC}$$

3.3.6 Turn at a designated TP

3.3.6.1 General

A designated TP is selected to allow the aircraft to avoid an obstacle straight ahead. The straight departure criteria apply up to the earliest TP.

3.3.6.2 Turn point tolerance

3.3.6.2.1 The longitudinal limits of the TP tolerance are:

- a) earliest limit, the end of the turn initiation area (K-line); and
- b) latest limit, determined by:
 - 1) K-line plus;
 - 2) TP fix tolerance plus; and
 - 3) flight technical tolerance *c*, where *c* is calculated in accordance with 3.3.4 h).

3.3.6.2.2 Where the TP is defined by passage over a navigation aid, the fix tolerance is computed at the elevation of the DER plus 10 per cent of the distance from the DER to the TP (i.e. allowing for a 10 per cent climb gradient). Where the TP is defined by a DME distance, the maximum angle that a line joining the TP and the DME may make with the nominal departure track shall not be more than 23°. (See Section 2, Chapter 2, 2.4.3, “Fixes for VOR or NDB with DME” and Figure I-2-2-1.)

3.3.6.3 Construction

- a) *Inner boundary*. The inner boundary of the turn area is constructed in accordance with Section 2, Chapter 3, “Turn area construction”.
- b) *Outer boundary*. The outer boundary of the turn area:
 - 1) begins at the latest TP tolerance (see also Figures I-3-3-11, a) b) c) and d)); and
 - 2) continues along the wind spiral or bounding circles constructed in accordance with Section 2, Chapter 3, “Turn area construction”; and up to the point (P) where the tangent becomes parallel to the nominal track after the turn. Examples of turns with track guidance after the turn, flying to or from a facility are provided in Figures I-3-3-11 c) and d) respectively.
- c) *For turns more than 90°* the area after the turn is constructed as shown on Figure I-3-3-12.

3.3.6.4 Obstacle clearance in the turn area

In order to ensure that the minimum obstacle clearance in the turn area has been provided, use the following equation to check the maximum height of an obstacle in the turn area above the elevation of the DER

$$\text{Maximum height of obstacle} = \text{PDG}(d_r + d_o) + H - \text{MOC}$$

- where: d_o = shortest distance from obstacle to line K-K (see Figure I-3-3-11 c)
- d_r = horizontal distance from DER to line K-K (earliest TP)
- PDG = promulgated procedure design gradient
- H = OIS height at DER (5 m or 16 ft)
- MOC = the greater of $0.008 (d_r + d_o)$ and 75 m (246 ft) (CAT H, 65 m (213 ft))

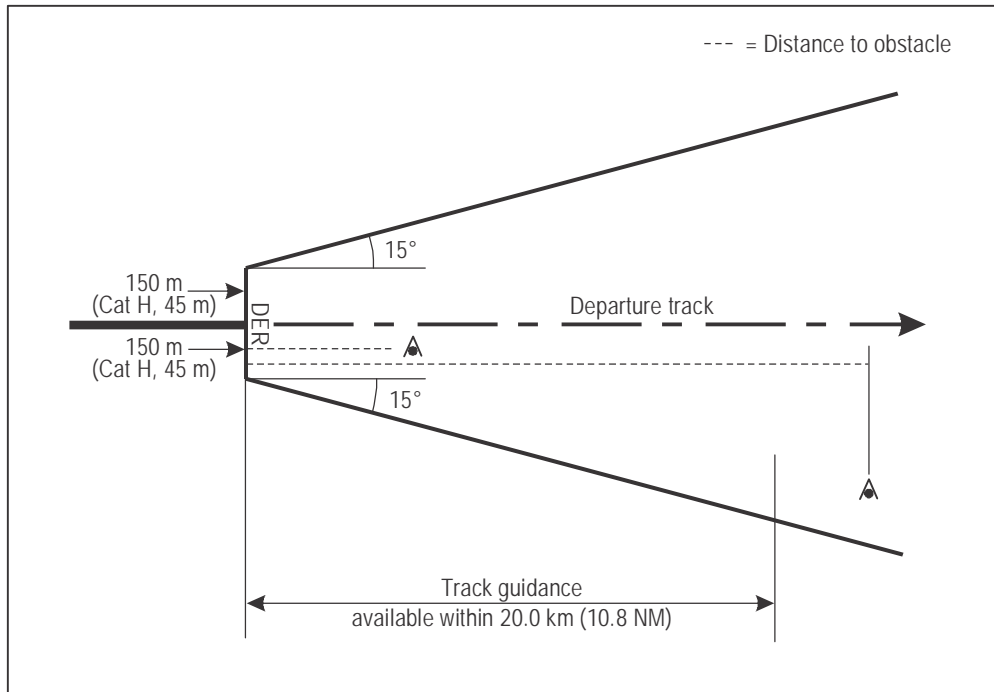

Figure I-3-3-1. Straight departure area without track guidance

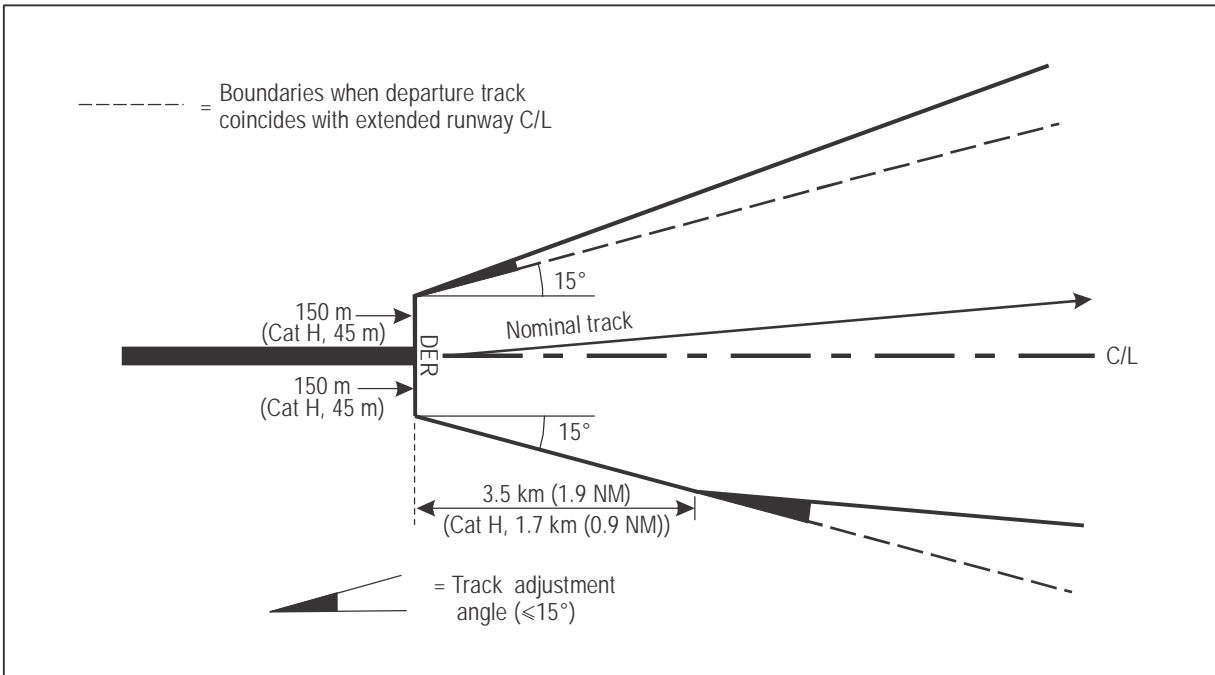

Figure I-3-3-2. Straight departure area with track adjustment (track adjustment point not specified)

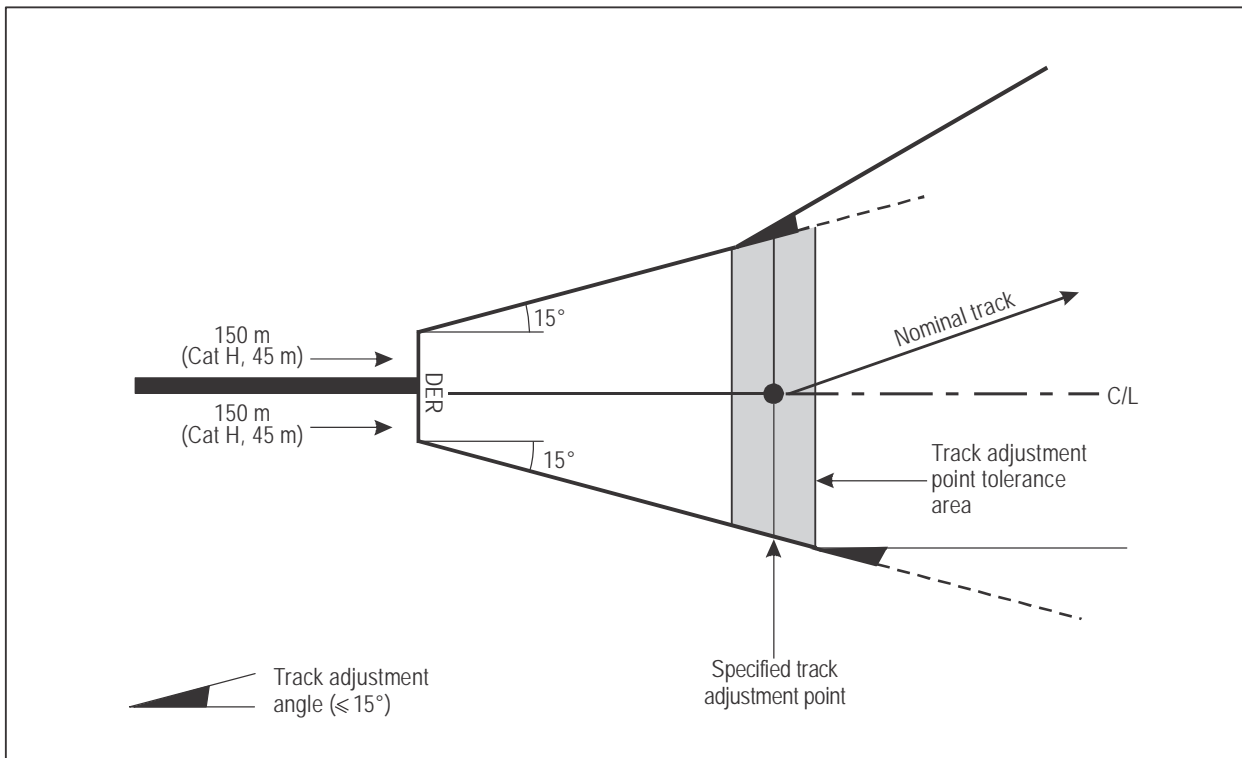

Figure I-3-3-3. Straight departure area with a specified track adjustment point

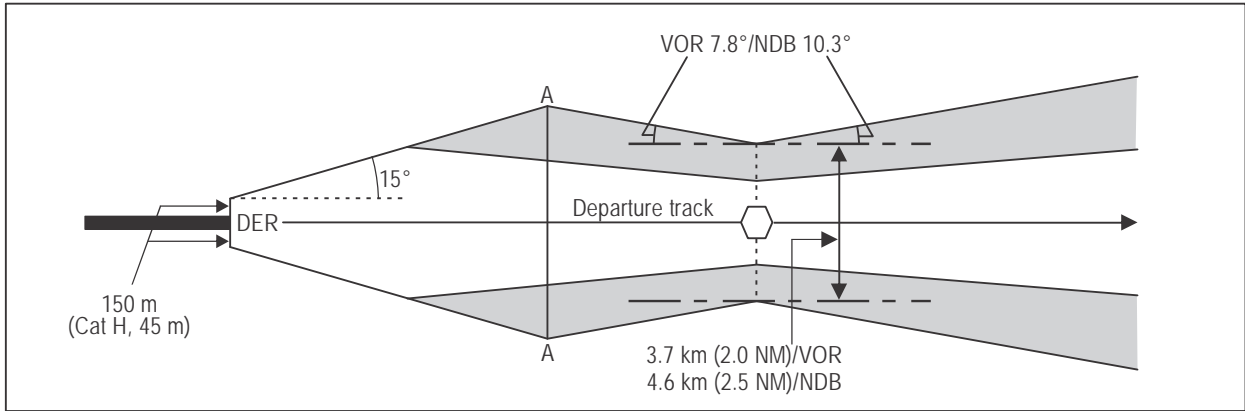

Figure I-3-3-4. Straight departure (facility ahead)

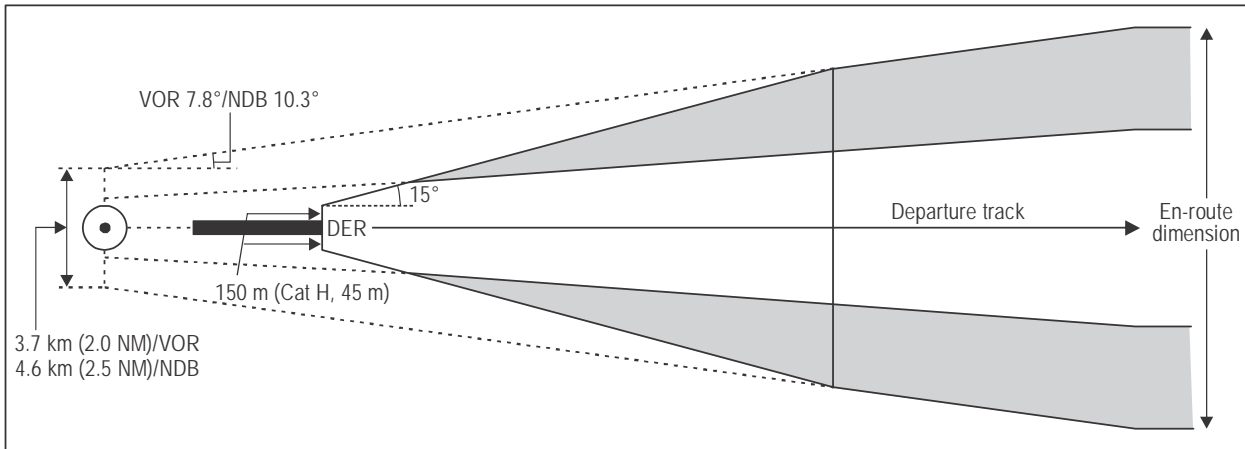

Figure I-3-3-5. Straight departure (facility behind)

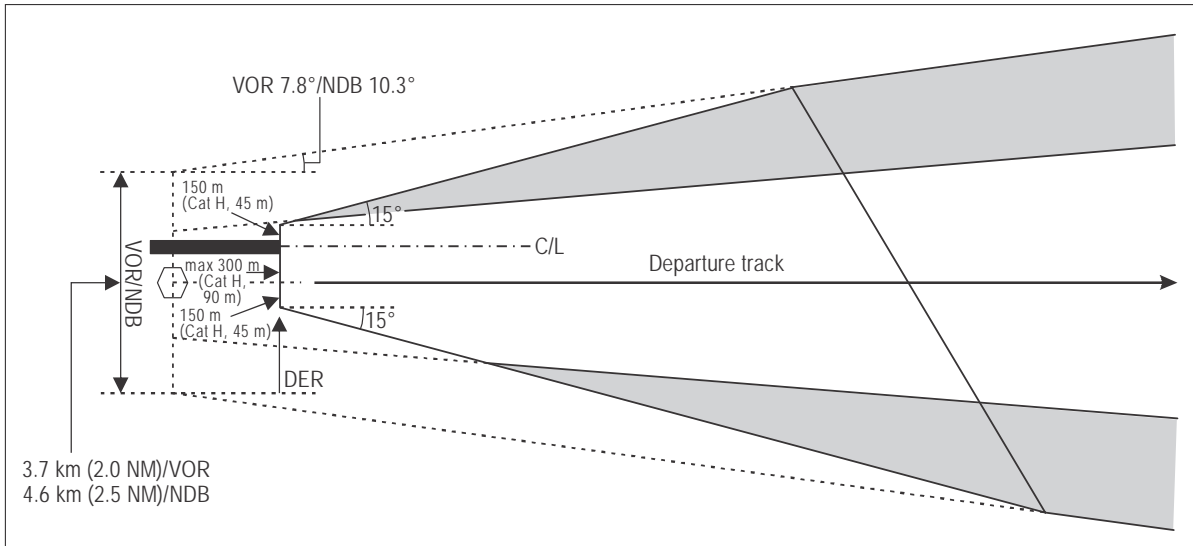

Figure I-3-3-6. Straight departure with offset departure track (track parallel to runway heading)

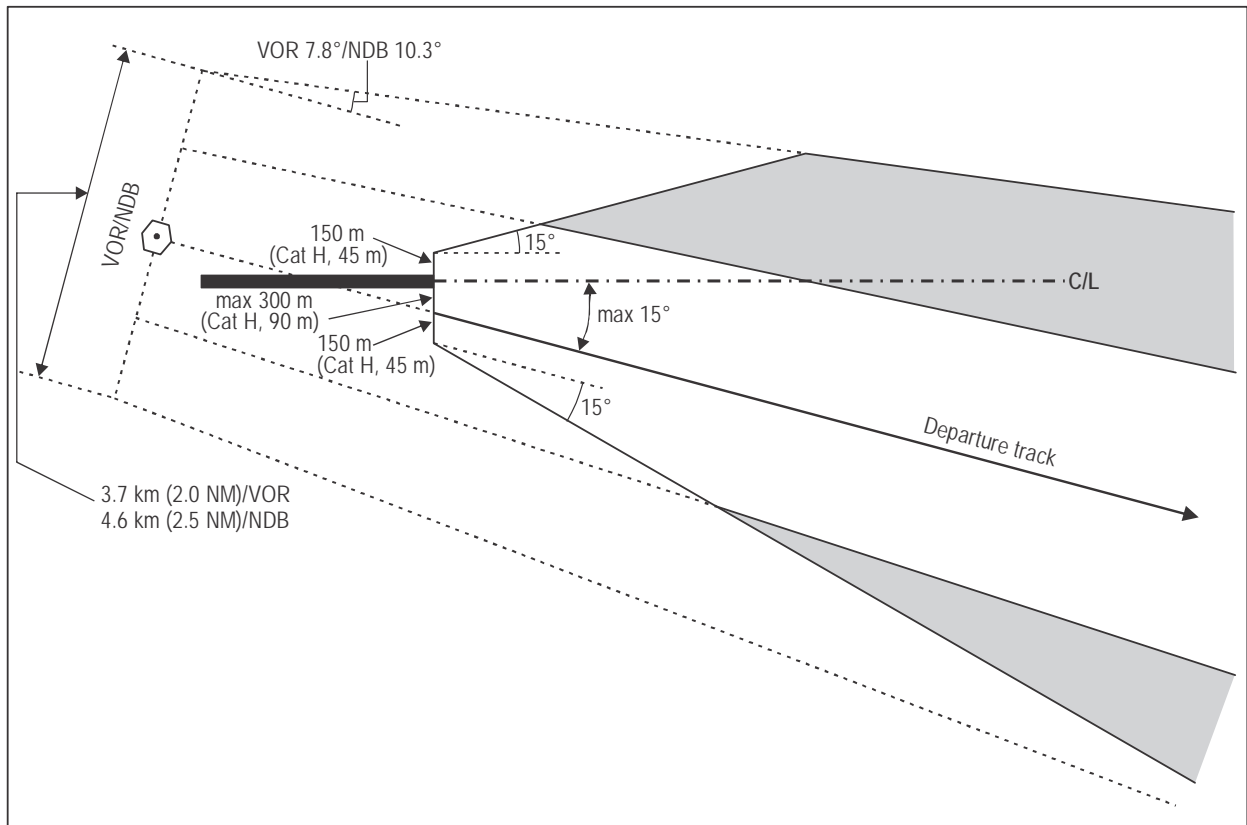

Figure I-3-3-7. Straight departure with offset departure track (track diverging from runway heading)

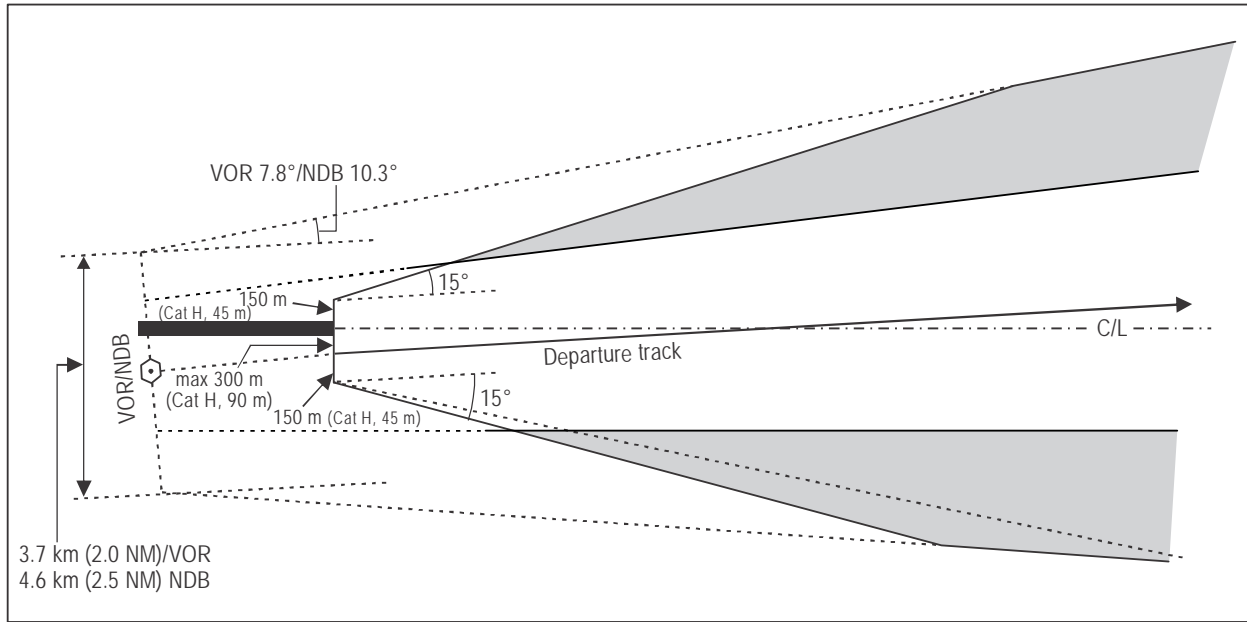

Figure I-3-3-8. Straight departure with offset departure track (track crossing runway heading)

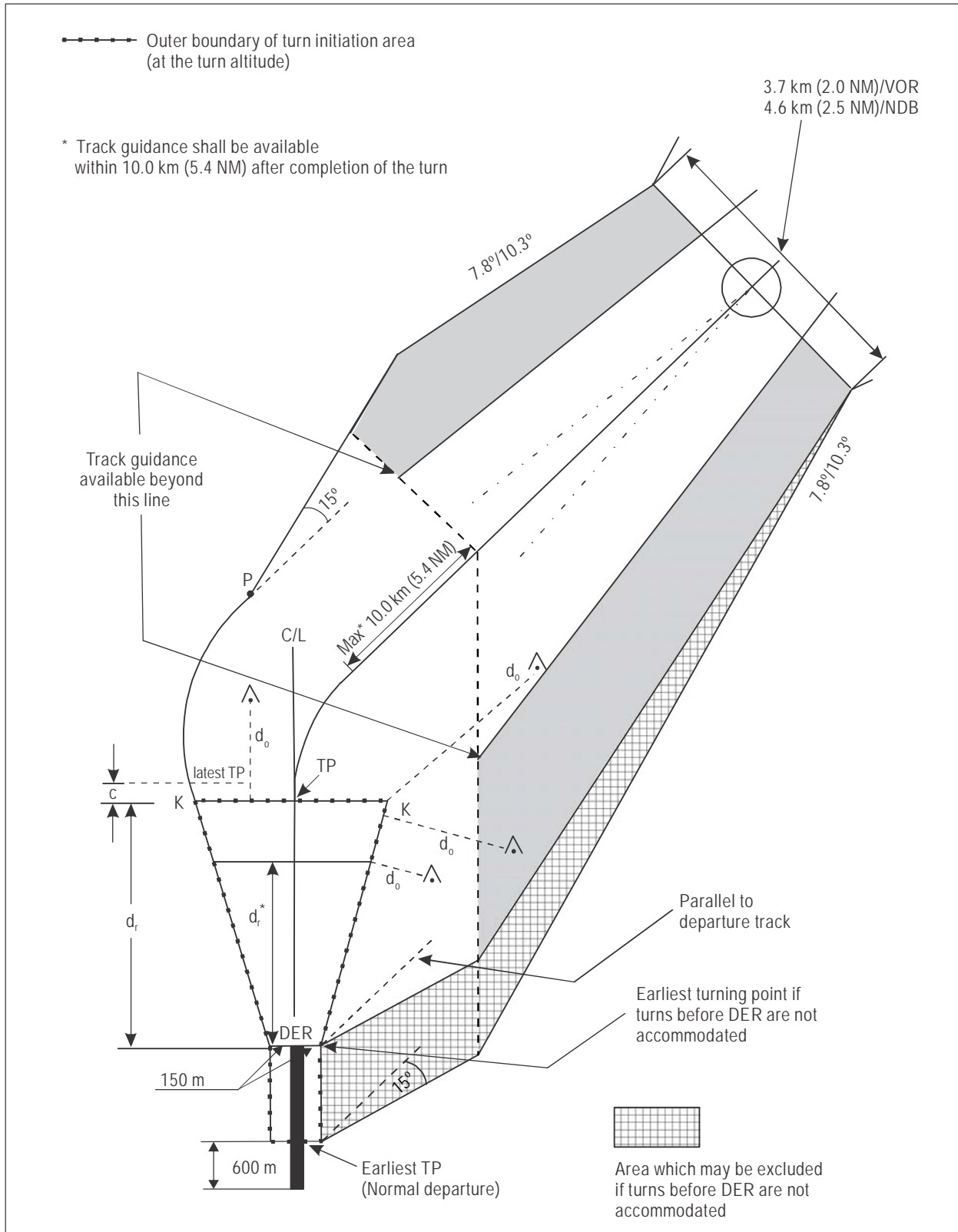

Figure I-3-3-9. Turning departure — turn at an altitude

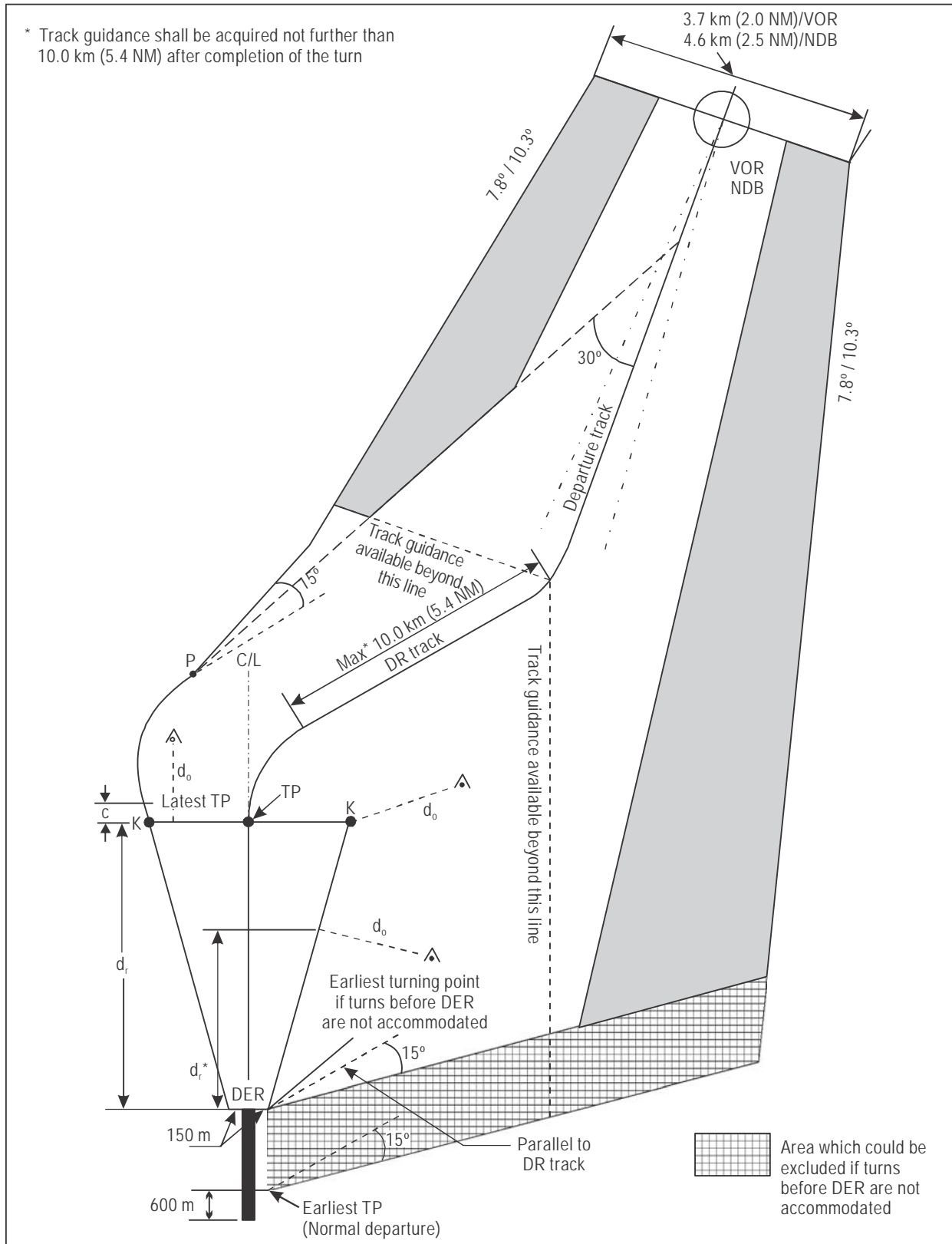

Figure I-3-3-10. Turning departure — turn at an altitude

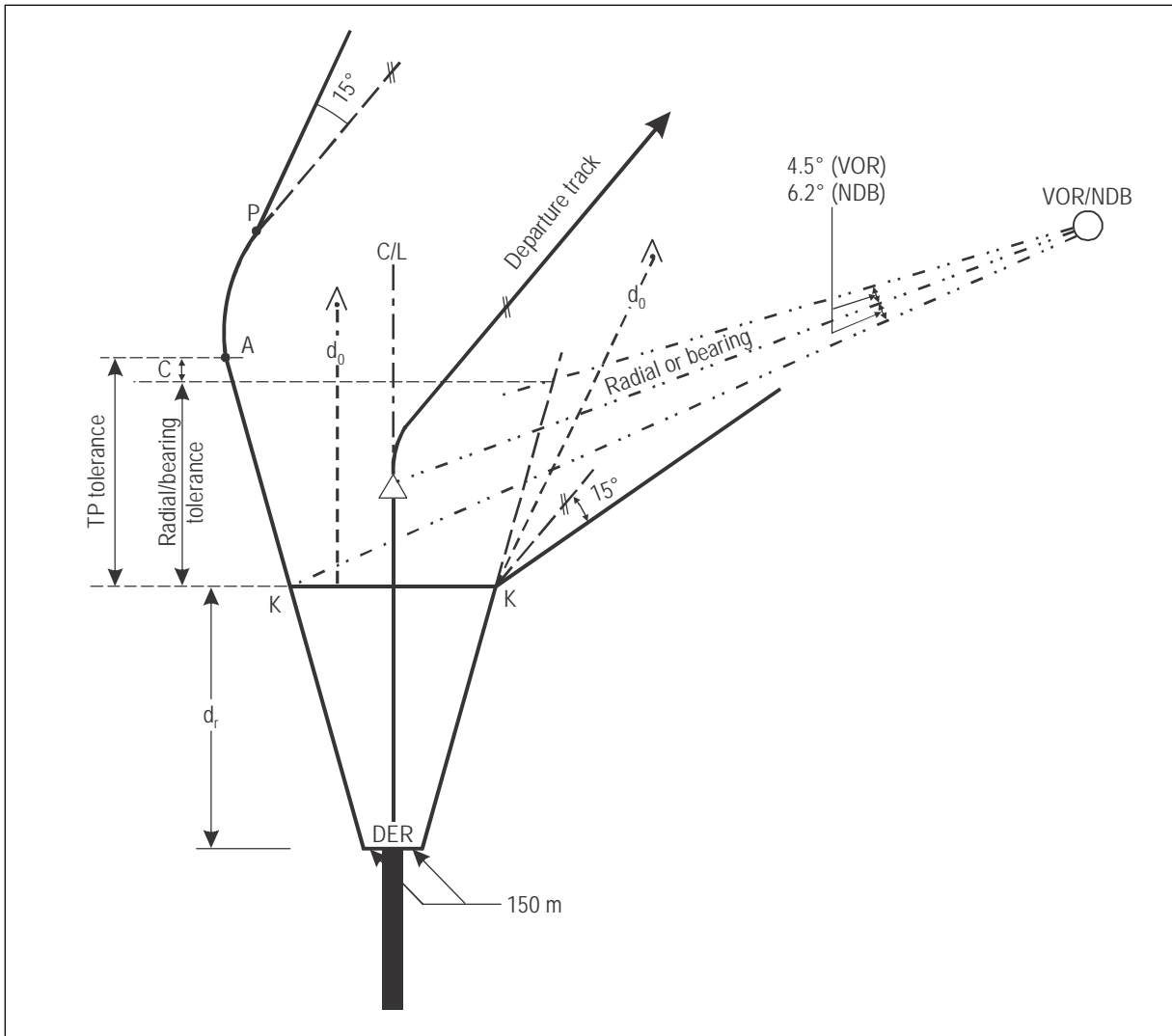

Figure I-3-3-11 a). Turning departure not overflying a facility — turning point tolerance area defined by intersecting radial

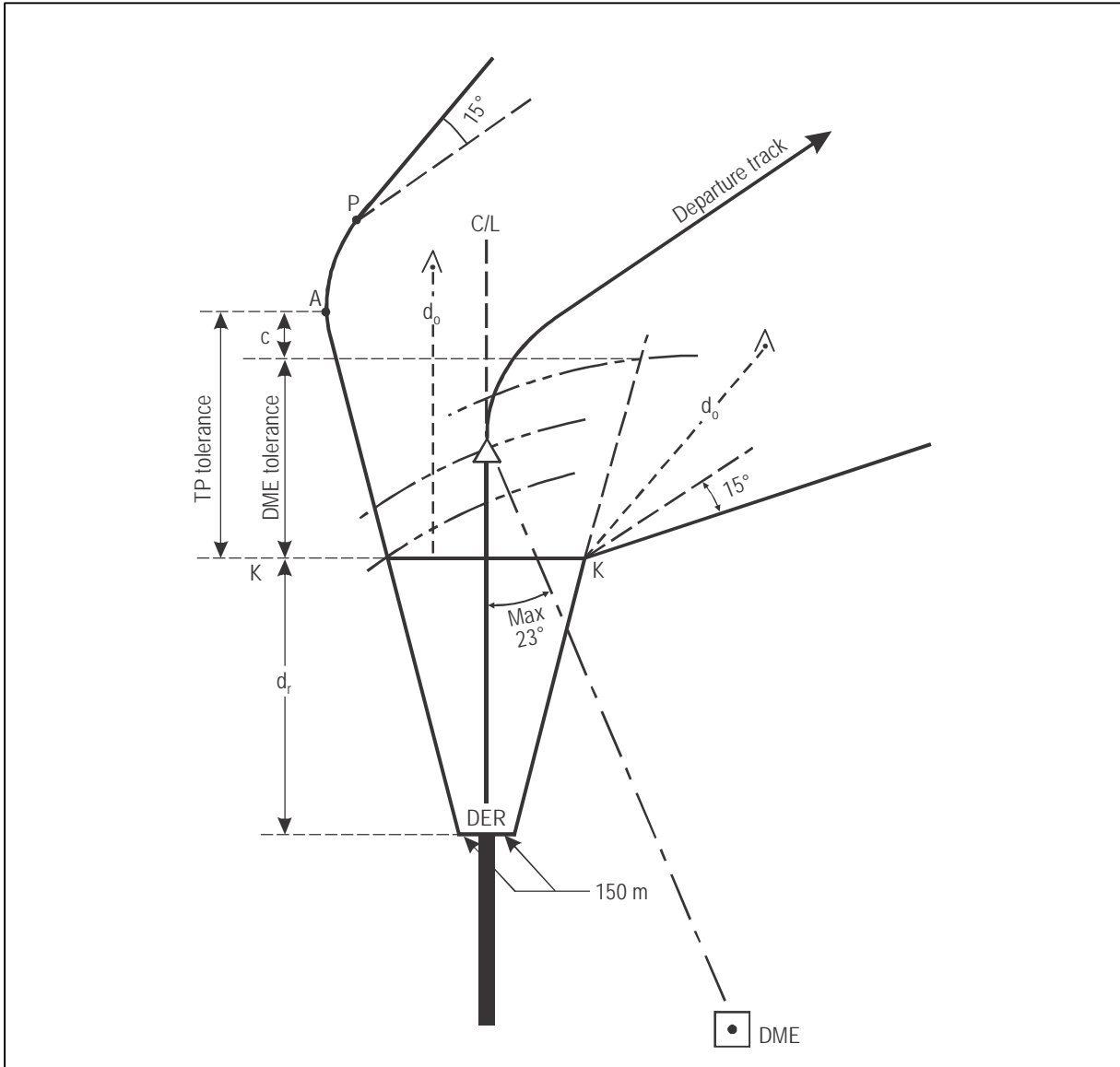

Figure I-3-3-11 b). Turning point not defined by overheading a facility (or RNAV fix)

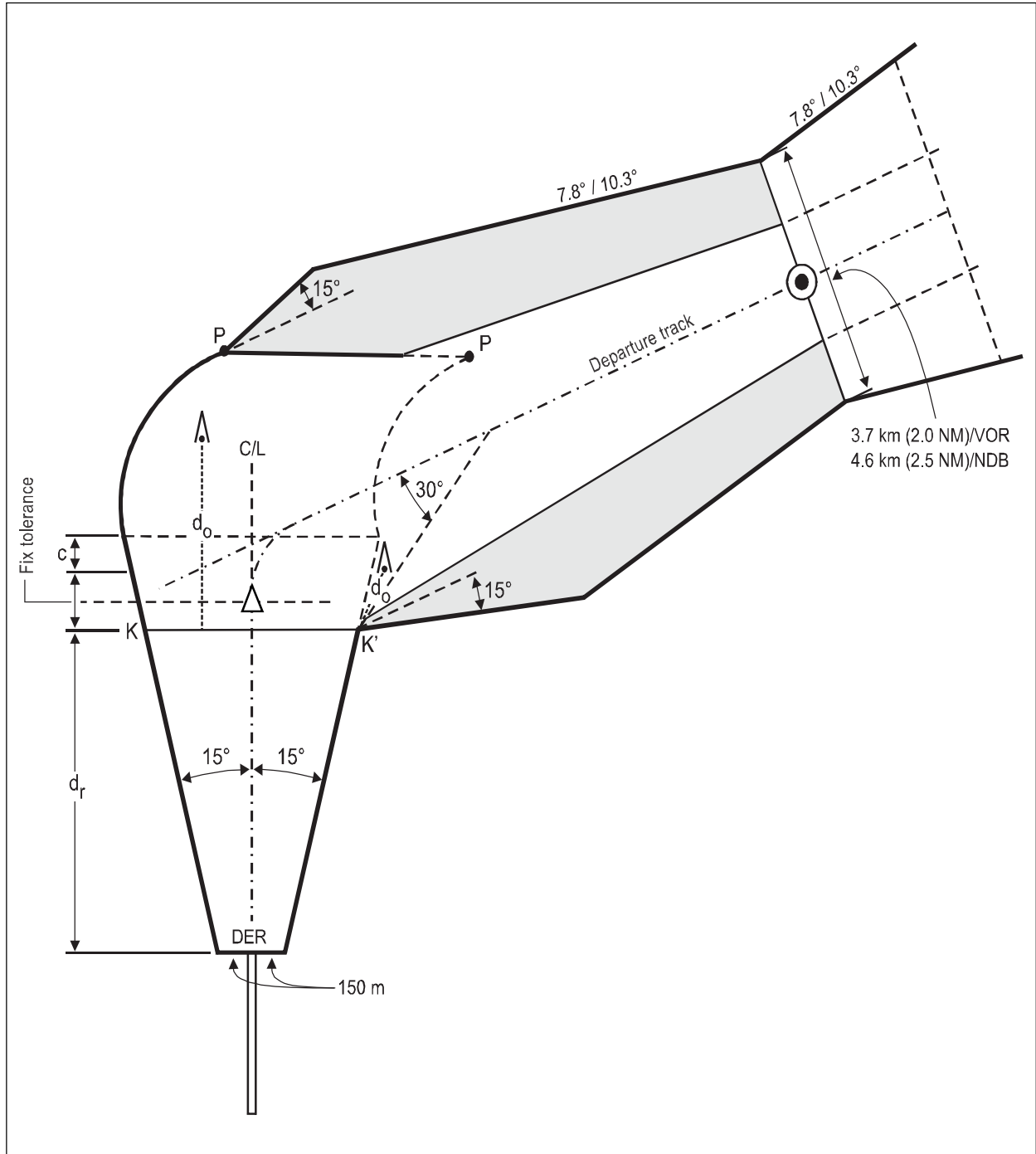

Figure I-3-3-11 c). Turning departure — turn at a fix

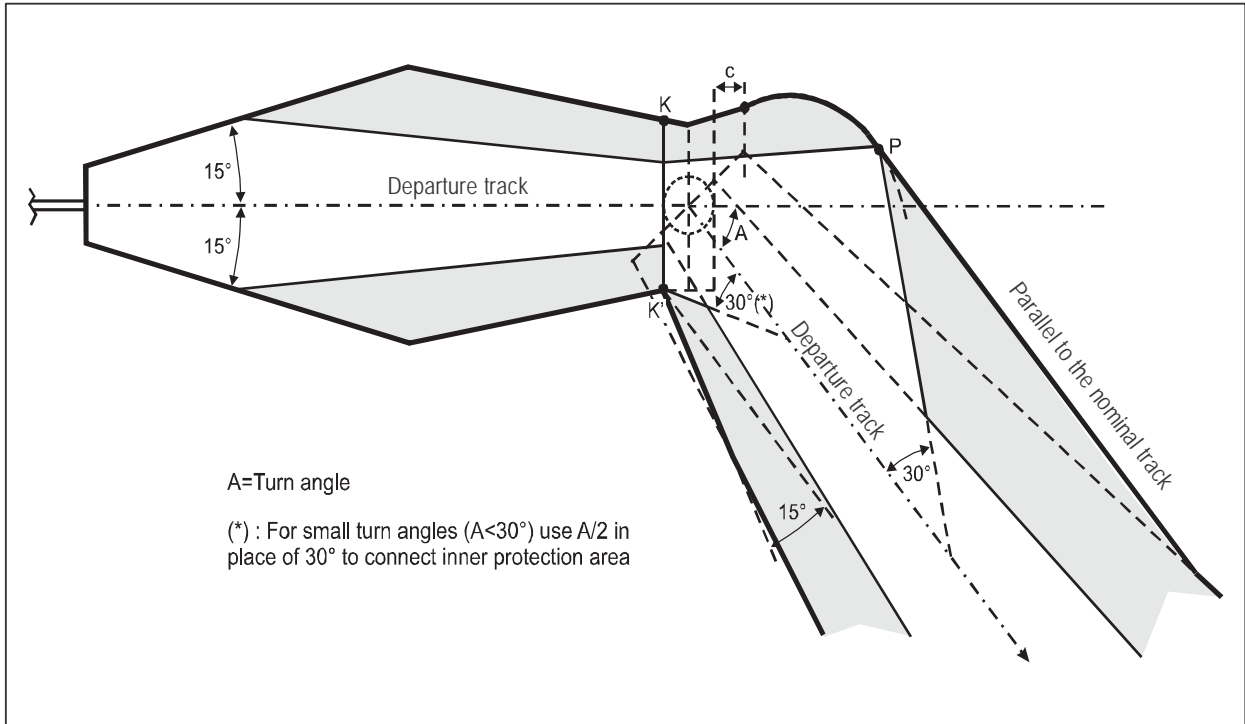

Figure I-3-3-11 d). Turning departure — turn over a facility

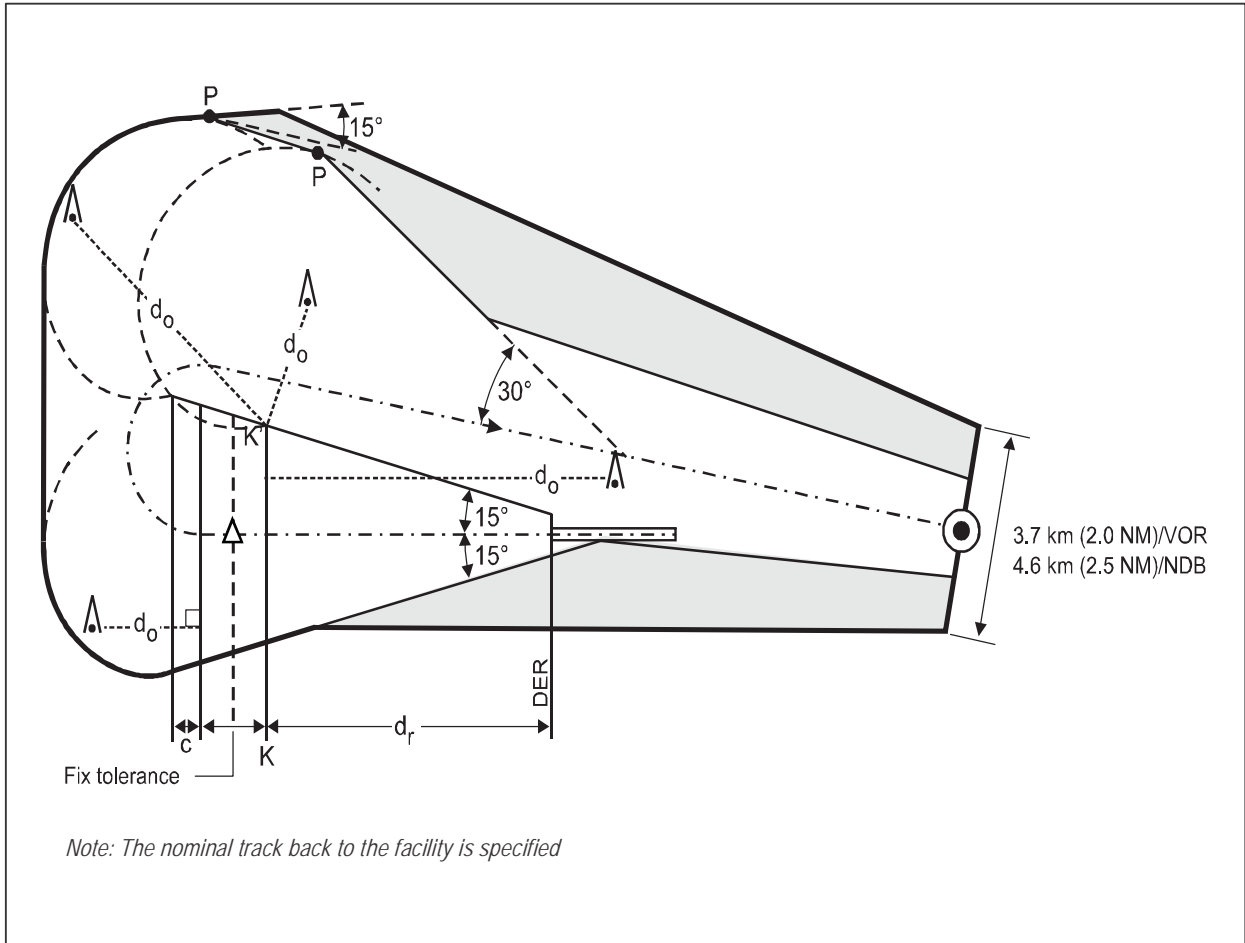

Figure I-3-3-12. Turning departure — turn at more than 90°

Appendix to Chapter 3

GUIDANCE ON ENVIRONMENTAL ISSUES

1. GENERAL

Although procedure designers are primarily concerned with obstacle clearance criteria, there are other important elements in procedure design, namely airspace requirements, ATS operational requirements and, in many cases, environmental requirements imposed by governmental organizations. This appendix provides guidance to the procedure designer to assist in meeting the increasing number of environmental constraints imposed on the design of new departure routes.

2. COOPERATION WITH NOISE ABATEMENT COMMITTEES IN PLANNING DEPARTURE ROUTES

2.1 In several States, committees have been established to minimize the disturbance to the local population caused by aircraft noise. Membership on these committees varies per State and may include citizens representing the populace of local communities/towns, local authorities and airport and airspace users such as the airport operator, air traffic services provider and airlines.

2.2 The tasks and importance of these committees also vary by State. Sometimes they may merely play a consultancy role, and in other cases they may act as a decision-making body. Also usually stipulated by law are the extent and required procedures by which the local noise abatement committees are included in the planning and introduction of new departure routes.

2.3 Safety shall always be the highest priority, however the competent authorities of each State could set subordinate priorities for capacity or environmental protection. When a noise abatement committee, which may lack adequate knowledge of procedure design, is involved in the development of departure procedures, it is essential that the importance to safety of the PANS-OPS criteria are made transparent to this committee. In cases where a State is required to deviate from PANS-OPS, it is strongly recommended that an aeronautical study be conducted to assess the effect on safety. This applies in all cases, even where political pressure for change is strong.

3. SPREADING NOISE VERSUS NOISE CONCENTRATION

3.1 General

3.1.1 When planning departure routes, it is generally feasible to define the aircraft containment area and its distribution. This allows the procedure designer either to concentrate or spread aircraft noise. Both methods are justifiable, depending on the population in the vicinity of the airport.

3.1.2 Concentrating aircraft on predictable flight paths has the advantage that noise-sensitive areas can be avoided. However, when applying this method, it is not always possible to avoid all populated areas, which could cause unfair

situations. This is especially the case with areas near the airport that are all densely populated to the same degree; therefore, sometimes spreading noise should be considered as an alternative.

3.1.3 The decision to spread or concentrate aircraft noise — or to combine both methods — should always be made for each individual airport, thereby taking into account the density of population and the recommendations of the affected noise abatement committee.

3.2 Methods to spread aircraft noise

In the planning of departure routes, the following methods can be used to achieve a natural distribution of aircraft and the spreading of aircraft noise:

- a) determination of different SID routes, e.g. by publishing the allocation of individual SIDs for use by certain aircraft types or aircraft categories;
- b) definition of turn at an altitude instead of turn at a turning point, to allow natural distribution of tracks due to different climb characteristics; and
- c) application of “omnidirectional departures” in connection with radar vectors.

3.3 Methods to concentrate aircraft noise

3.3.1 Aircraft noise can be concentrated when departure routes are flown as accurately as possible, therefore it is advantageous to use RNAV-equipped aircraft. Given that all departure routes (including conventional routes) are coded by the database providers for FMS systems in the aircraft, it is important that the information contained in the SID description be clearly and unequivocally coded for the FMS system.

3.3.2 In order for RNAV procedures to be flown accurately, they shall be designed to take into account the aircraft performance characteristics, and therefore PANS-OPS criteria shall be applied.

3.3.3 In addition, it is very important that the procedure designer be aware of the range of capabilities (performance and navigational) of the aircraft that are expected to use the procedure. For example, it may be impossible for a large, long-haul jet to follow a departure procedure designed for a small, short-haul turboprop. Also, specifically, radius-to-fix turns should be avoided if a significant percentage of the traffic will not have such a capability.

4. GUIDANCE MATERIAL ON THE ESTABLISHMENT OF THE AVERAGE FLIGHT PATH OF A DEPARTURE PROCEDURE

4.1 Introduction

When close conformance to an accurate track, especially for turning departures, is important (for noise abatement/ATC constraints, etc.), statistical data on aircraft performance can be used to determine the procedure with the average flight path. The aircraft performances used to determine the average flight path must not be used for obstacle clearance calculation purposes. Although the data in Table I-3-3-App-1 are based on Cat D type of aircraft, it may also be applied to procedures for aircraft of lower category, causing an acceptable additional margin. In order to show the effect of this method, the average flight path is drawn on Figures I-3-3-App-1, I-3-3-App-2, I-3-3-App-3 and I-3-3-App-4.

4.2 Construction of the desired average flight path

4.2.1 Purpose

For the departure, the desired average flight path to deal with restrictions such as noise or ATC constraints can be drawn according to the speed/distance/bank angle in Table I-3-3-App-1. The purpose of the table is to give guidance for a realistic speed. For example it can be verified whether a proposed speed limitation would cause an operational problem. For RNAV procedure design, this table can be used as guidance for the minimum stabilization distance determination.

4.2.2 Table description

4.2.1.1 The indicated airspeed (IAS), bank angle and height above aerodrome can be found as a function of the distance from the DER. Apply the “along track” distance from the DER to the turning point/waypoint. When a speed restriction lower than the speed corresponding to a given distance in the speed table is required, this speed supersedes the value in the table.

4.2.2.2 For conversion from IAS to TAS (using Section 2, Appendix to Chapter 1), the climb of the aircraft must be taken into account. Use the altitude value from Table I-3-3-App-1 in the Appendix to Chapter 1 to convert IAS to TAS. A seven per cent climb gradient is applied originating from the DER. If a procedure design gradient higher than 7 per cent is used for obstacle clearance purposes or if a higher air traffic services (ATS) climb gradient is required, that climb gradient supersedes the assumed gradient in the table.

4.2.2.3 Due to probable limitation of bank angles as a function of altitude in the initial phase of the departure procedure:

- a) a 15° bank angle is applied until 305 m (1 000 ft); and
- b) a 25° bank angle from 915 m (3 000 ft) onwards.

As the resulting turn radii are influenced by a different bank angle, for a smooth transition a 20° bank angle is used between 305 m (1 000 ft) and 915 m (3 000 ft).

5. SUPPORT BY SOFTWARE TOOLS

Software tools are available that can be used by the procedure designer to assist in noise abatement optimization of the departure route design. Features of such supporting tools may include:

- a) scientific consideration of population density and calculation of minimum noise routings;
- b) display of real flight tracks on topographical maps; and
- c) assessment of the flyability of a procedure by computer simulation.

Table I-3-3-App-1. Average flight path determination
(Distance in km (NM), height in m (ft), bank angle in degrees, speed in km/h (kt) IAS)

Distance from DER	1.9 (1)	3.7 (2)	5.6 (3)	7.4 (4)	9.3 (5)	11.1 (6)	13 (7)	14.8 (8)	16.7 (9)	18.5 (10)	20.4 (11)	22.2 (12)	24.1 (13)	25.9 (14)	27.8 (15)	29.6 (16)	31.5 (17)	33.3 (18)	35.2 (19)	37 (20)	38.9 (21)	40.7 (22)	42.6 (23)	44.4 (24)	46.3 (25)
Height above rwy	130 (425)	259 (850)	389 (1 275)	518 (1 700)	648 (2 125)	777 (2 550)	907 (2 976)	1037 (3 401)	1167 (3 827)	1296 (4 252)	1476 (4 677)	1556 (5 103)	1685 (5 528)	1815 (5 953)	1945 (6 379)	2074 (6 804)	2204 (7 229)	2334 (7 655)	2463 (8 080)	2593 (8 505)	2723 (8 931)	2892 (9 356)	2982 (9 781)	3112 (10 207)	3241 (10 632)
Bank angle	15	15	20	20	20	20	20	25	25	25	25	25	25	25	25	25	25	25	25	25	25	25	25	25	25
Speed	356 (192)	370 (200)	387 (209)	404 (218)	424 (229)	441 (238)	452 (244)	459 (248)	467 (252)	472 (255)	478 (258)	483 (261)	487 (263)	491 (265)	493 (266)	494 (267)	498 (269)	502 (271)	504 (272)	511 (276)	515 (278)	519 (280)	524 (283)	526 (284)	530 (286)

Note.— The speed shall not be higher than the maximum speed as indicated in Table I-4-1-1 and I-4-1-2.

Example:

Applicable data:

- 1 — Altitude aerodrome: 715 m (2 346 ft) MSL
- 2 — Required turn after 31.5 km (17 NM) track-miles flown

Find from the table:

- 1 — Assumed height aircraft: 2 204 m (7 229 ft) above field elevation
- 2 — Bank angle 25°
- 3 — Speed: 498 km/h (269 kt) IAS

Calculate turn radius:

- 1 — Altitude aircraft is 715 m (2 346 ft) (aerodrome elevation) + 2 204 m (7 229 ft) (height aircraft) = 2 919 m (9 575 ft) MSL
- 2 — TAS conversion factor (Section 2, Appendix to Chapter 1) rounded up to 10 000 ft: 1.1958
- 3 — TAS: 498 km/h (269 kt) × 1.1958 = 596 km/h (322 kt)
- 4 — Turn radius average flight path 6.00 km (3.24 NM) (refer to Section 2, Chapter 3, paragraph 2, “radius of turn”).

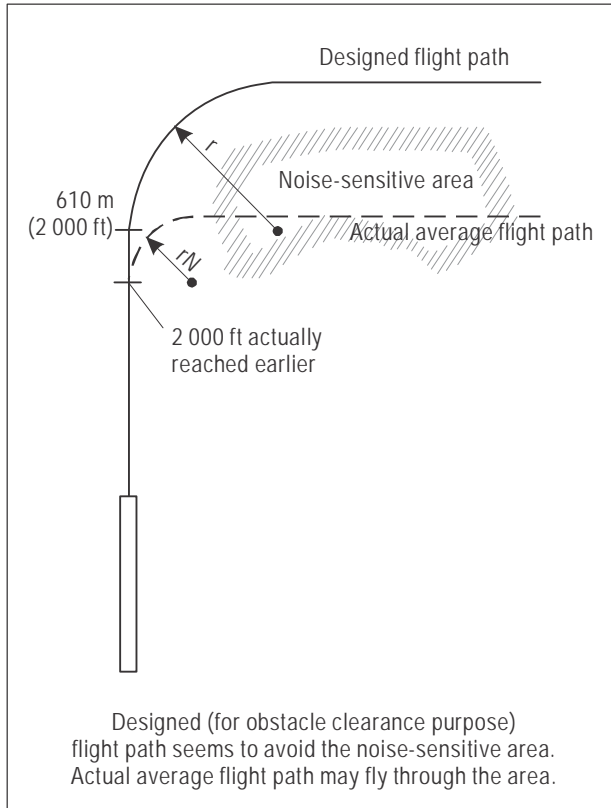

Figure I-3-3-App-1. Turn at a designated turning altitude — procedure without application of statistical data

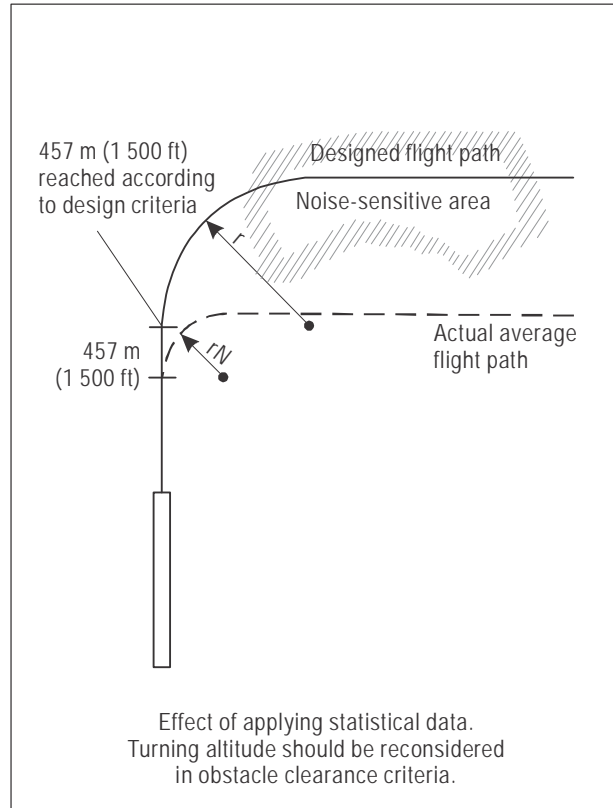

Figure I-3-3-App-2. Turn at a designated turning altitude — procedure with application of statistical data

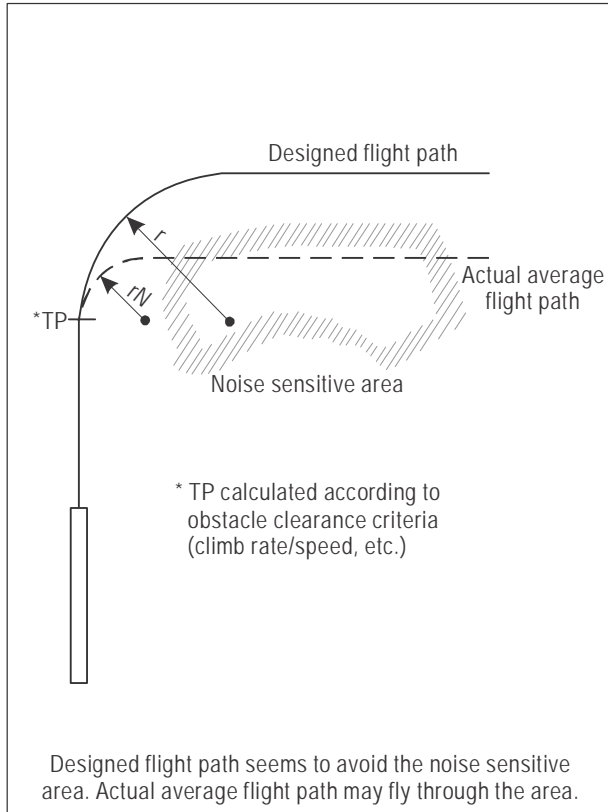

Figure I-3-3-App-3. Turn at a designated TP — procedure without application of statistical data

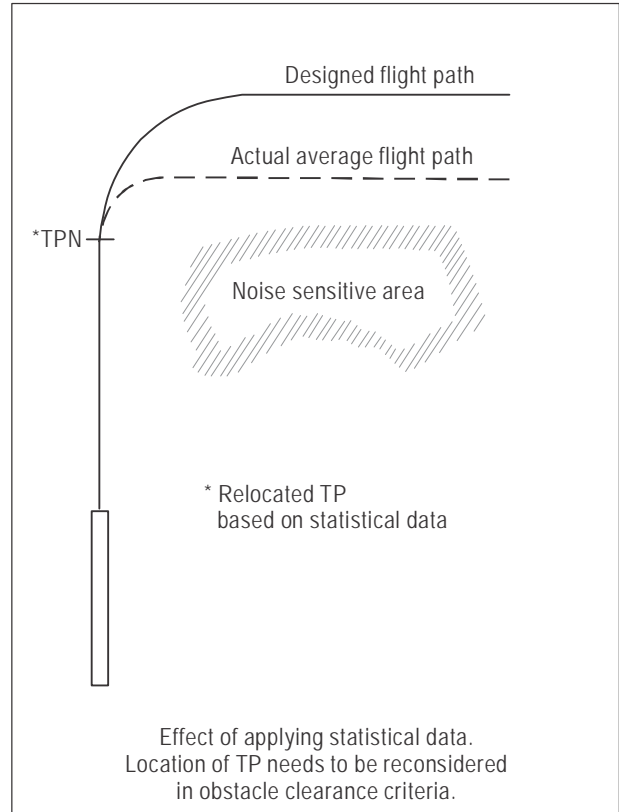

Figure I-3-3-App-4. Turn at a designated TPN — procedure with application of statistical data

Chapter 4

OMNIDIRECTIONAL DEPARTURES

4.1 GENERAL

4.1.1 At many aerodromes, a departure route is not required for ATC purposes or to avoid particular obstacles. Nevertheless, there may be obstacles in the vicinity of the aerodrome which affect departures and an omnidirectional departure procedure is a convenient and flexible method of ensuring g obstacle clearance.

4.1.2 An omnidirectional departure procedure is designed on the basis that an aircraft maintains runway direction until a height of 120 m (394 ft) (Cat H, 90 m (295 ft) above the elevation of the DER before commencing a turn.

4.1.3 Where additional height is required for obstacle clearance the straight departure is continued until reaching the required turn altitude/height. A turn of no more than 15° is permitted during this extension of the straight departure. On reaching the specified turn altitude/height a turn in any direction may be made to join an en-route segment.

4.1.4 An omnidirectional departure may specify sectors with altitude or PDG limitations or may specify sectors to be avoided. Omnidirectional departures shall be published in accordance with Chapter 5.

4.2 AREAS

4.2.1 Turn initiation area

In omnidirectional turns, the turn initiation area is divided into two areas: Area 1 and Area 2.

4.2.1.1 Area 1

The turn initiation area is as described in Chapter 3 up to the point at which the PDG reaches the minimum turn height (120 m/394 ft, Cat H, 90 m/295 ft). This is Area 1. (See Figure I-3-4-1.)

4.2.1.2 Area 2

Past that point the turn initiation area splays at an angle of 30° to the departure track until the specified turn altitude/height is reached. This is Area 2 (see Figure I-3-4-1). Track adjustments of 15° or less may be made.

4.2.2 Turn area (Area 3)

4.2.2.1 The turn area (Area 3) provides for departures involving turns more than 15° (see Figure I-3-4-2). It covers the remaining portion of a circle centred on a point on the runway centre line 600 m from the start of take-off (Cat H, the beginning of the runway or the FATO).

4.2.2.2 The radius of the circle is determined by the distance required at the PDG to reach the next en-route segment level or MSA.

4.3 OBSTACLE IDENTIFICATION

4.3.1 Turn initiation area OIS

A 2.5 per cent (Cat H, 4.2 per cent) OIS extends from 5 m (16 ft) above the elevation of the DER to the end of the turn initiation area.

4.3.2 Identification of obstacles in the turn area

4.3.2.1 An obstacle in the turn area shall be considered if it penetrates a 2.5 per cent gradient (CAT H, 4.2 per cent) which starts at the boundary of the turn initiation area at a height of 75 m (246 ft) (CAT H, 65 m (213 ft)) above the elevation of the DER. The gradient is computed using the shortest distance from the boundary of the turn initiation area to the obstacle.

4.3.2.2 Unless the procedure prohibits turns prior to the DER, an area beginning 600 m from the start of take-off to the DER extending 150 m either side of the runway centre line shall be included in the turn initiation area for this purpose. (For helicopters this area commences at the start of the runway or the area available for take-off and extends 45 m either side of the runway/FATO.) (See dotted boundary in Figure I-3-4-2.)

4.4 OBSTACLE CLEARANCE

4.4.1 Obstacle clearance in the turn initiation area

Obstacle clearance in the turn initiation area is as required in Chapter 3 for a turn at a specified altitude.

4.4.2 Obstacle clearance in the turn area

a) The minimum obstacle clearance in the turn area is the greater of:

- 1) 75 m (246 ft) (CAT H, 65 m (213 ft)); and
- 2) $0.008 (d_r^* + d_o)$, where:

d_r^* is the distance measured along the departure track corresponding to the point on the turn initiation area boundary where the distance d_o is measured; and

d_o is the shortest distance from the turn initiation area boundary to the obstacle.

b) The maximum permissible elevation/height of an obstacle in the turn area can be computed by:

$$\text{Maximum obstacle elevation/height} = \text{TNA/H} + d_o \text{ PDG} - \text{MOC}$$

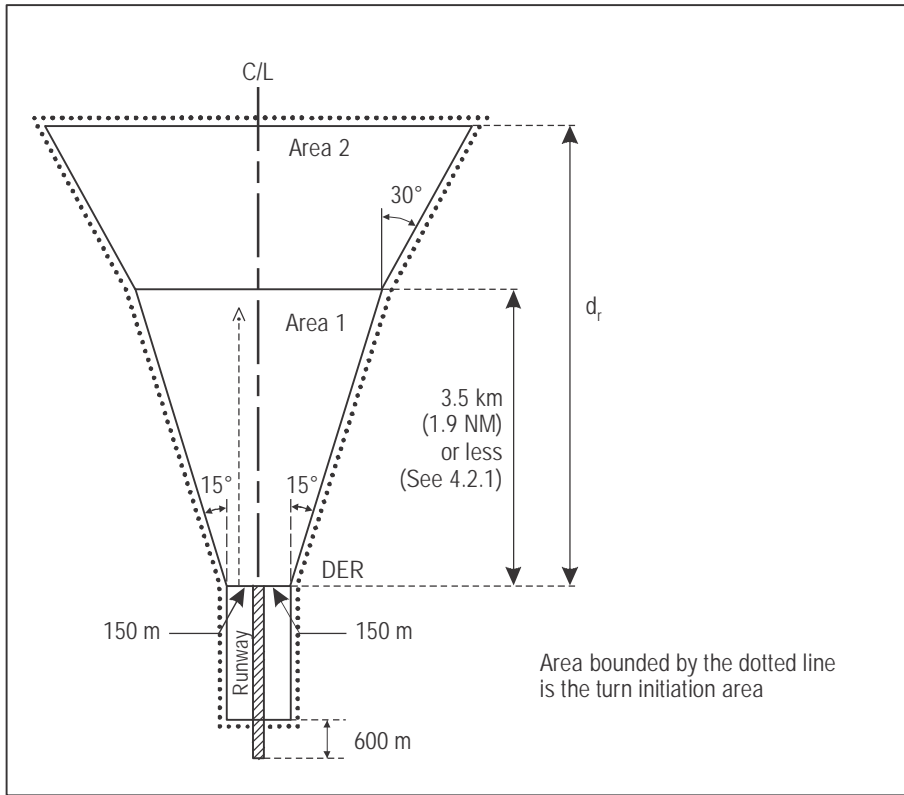

Figure I-3-4-1. Areas 1 and 2 and turn initiation area for omnidirectional departure

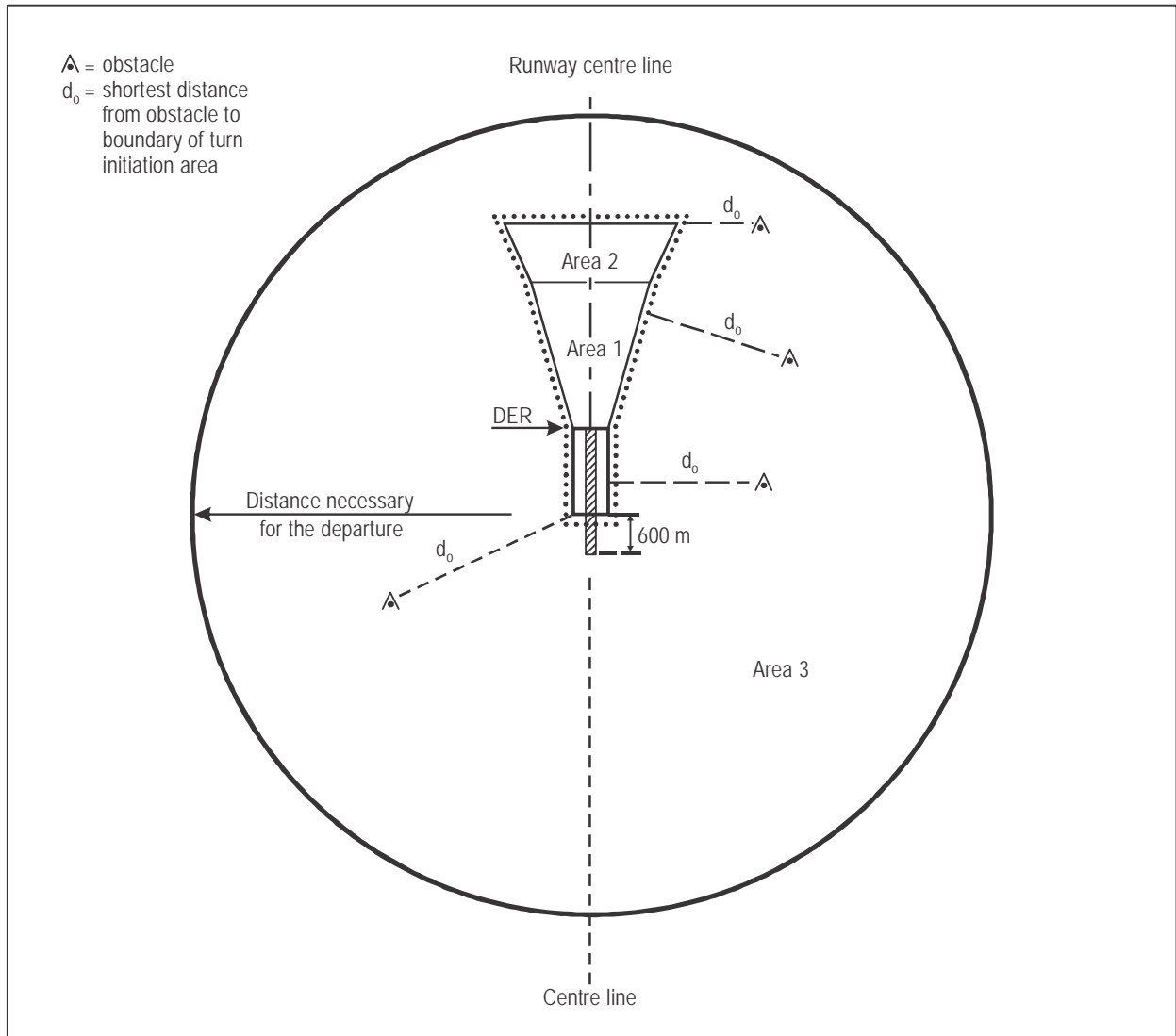

Figure I-3-4-2. Area 3 for omnidirectional departure

Chapter 5

PUBLISHED INFORMATION FOR DEPARTURE PROCEDURES

5.1 GENERAL

The minimum information to be published for a departure procedure is as follows:

- a) all tracks, points, fixes and altitudes/heights (including turn altitudes/heights) required by the procedure;
- b) all navigation facilities, fixes, waypoints, radials and DME distances used to define route segments;
- c) significant obstacles which penetrate the obstacle identification surfaces (OIS);
- d) the position and height of close-in obstacles penetrating the OIS. A note shall be included on the departure chart wherever close-in obstacles exist which were not considered in the determination of the published procedure design gradient (PDG) (see Figure II-3-2-3 in Chapter 2);
- e) the highest obstacle in the departure area, and any significant obstacle outside that area controlling the design of the procedure;
- f) a PDG greater than 3.3 per cent and the altitude/height to which it applies;
- g) the altitude/height or fix at which a gradient in excess of 3.3 per cent (Cat H, 5.0 per cent) ceases to be required (see Figure I-3-5-1);
- h) where an increased procedure design gradient is required by airspace restrictions only, a note stating that condition e.g. “4% climb gradient required due airspace restrictions only”;
- i) altitude/heights to be achieved at significant points in the departure, identified by navigation aids or fixes; and
- j) when close conformance to a track is important (e.g. noise abatement/ATC constraints) a note stating that the average flight path is designed using statistical aircraft performance data (for construction of the average flight path, see the Appendix to Chapter 3).

Note.— Principles governing the identification of standard departure routes are contained in Annex 11, Appendix 3. Specifications for standard instrument departure charts are contained in Annex 4.

5.2 OMNIDIRECTIONAL DEPARTURES

An omnidirectional departure that restricts turn altitudes/heights and/or procedure design gradients to sectors shall be promulgated as follows:

- a) restrictions shall be shown as sectors in which minimum altitudes and minimum turn altitudes/heights are specified, or in which stated procedure design gradients are required;

- b) sectors may be defined in which flight is not permitted;
- c) sectors shall be described by bearings and distance from the centre of the turn area;
- d) sectors shall diverge at least 15° either side of the controlling obstacle; and
- e) when more than one sector is published, the promulgated gradient shall be the highest PDG required in any sector that may be entered. The altitude/height to which the gradient applies must permit the subsequent use of a 3.3 per cent gradient (Cat H, 5.0 per cent) through that sector, a succeeding sector, or to an altitude/height authorized for another phase of flight (i.e. en-route holding or approach). A fix may also be designated to mark the point at which a gradient in excess of 3.3 per cent (Cat H, 5.0 per cent) ceases.

5.3 CHARTED ALTITUDES/FLIGHT LEVELS

Departure procedures may be developed to procedurally separate air traffic. In doing so, the procedure may be accompanied by altitudes/flight levels that are not associated with any obstacle clearance requirements, but are developed to separate arriving and departing air traffic procedurally. These altitudes/flight levels shall be charted as indicated in Table I-3-5-1. The method of charting of altitudes/flight levels to correctly depict the designed procedure may differ between avionics manufacturers.

5.4 OTHER REQUIREMENTS

- a) When departures are limited to a particular category(ies) of aircraft, the procedure shall be clearly annotated.
- b) Where a suitable fix is available, a procedure design gradient requirement may be promulgated by specifying a DME distance/altitude or position/altitude restriction (e.g. “reach 5 000 ft by DME 15” or “reach 3 500 ft by VWXYZ”).
- c) A turn may be specified at a fix or an altitude/height, e.g. “at DME 4 turn right, track 170°” or “at 2 500 ft turn left track to VWXYZ”.
- d) When it is necessary, after a turn, to track to intercept a specified radial/bearing, the procedure will specify:
 - 1) the turning point;
 - 2) the track to be made good; and
 - 3) the radial/bearing to be intercepted;(e.g. “at DME 4 turn left, track 340° to intercept BNE R020 (VOR)”; or “at DME 2 turn left, track 340° to intercept 010° track to STN (NDB)”).
- e) Where a PDG in excess of the standard gradient is required to provide obstacle clearance, an alternative procedure using a lower PDG may be published for operations in VMC only.
- f) Gradients to a height of 60 m (200 ft) or less due to close-in obstacles shall not be promulgated. A note shall be published stating that close-in obstacles exist.

- g) Where a suitably located DME exists, or when suitably located RNAV fixes can be established, additional specific height/distance information intended for obstacle avoidance should be published in order to provide a means of monitoring aircraft position relative to critical obstacles.
- h) Where turns prior to the DER are not accommodated, and the procedure design is based upon the turn initiation area commencing at the DER, the departure procedure shall include a note that turns are not permitted prior to the DER.

Table I-3-5-1. Charted altitudes/flight levels

Altitude/Flight level “Window”	<u>17 000</u>	<u>FL220</u>
	<u>10 000</u>	<u>10 000</u>
“At or above” altitude/flight level	<u>7 000</u>	<u>FL60</u>
“At or below” altitude/flight level	<u>5 000</u>	<u>FL50</u>
“Mandatory” altitude/flight level	<u>3 000</u>	<u>FL30</u>
“Recommended” procedure altitude/flight level	5 000	FL50
“Expected” altitude/flight level	Expect 5 000	Expect FL50

Because of obstacle B, the gradient cannot be reduced to 3.3% (2.5% + 0.8%) (Cat H, 5.0 per cent) just after passing obstacle A. The altitude/height or fix at which a gradient in excess of 3.3% (Cat H, 5.0 per cent) is no longer required is promulgated in the procedure.

Obstacles A and B will be promulgated. Mountain promulgated on Aerodrome Obstacle Chart Type C.

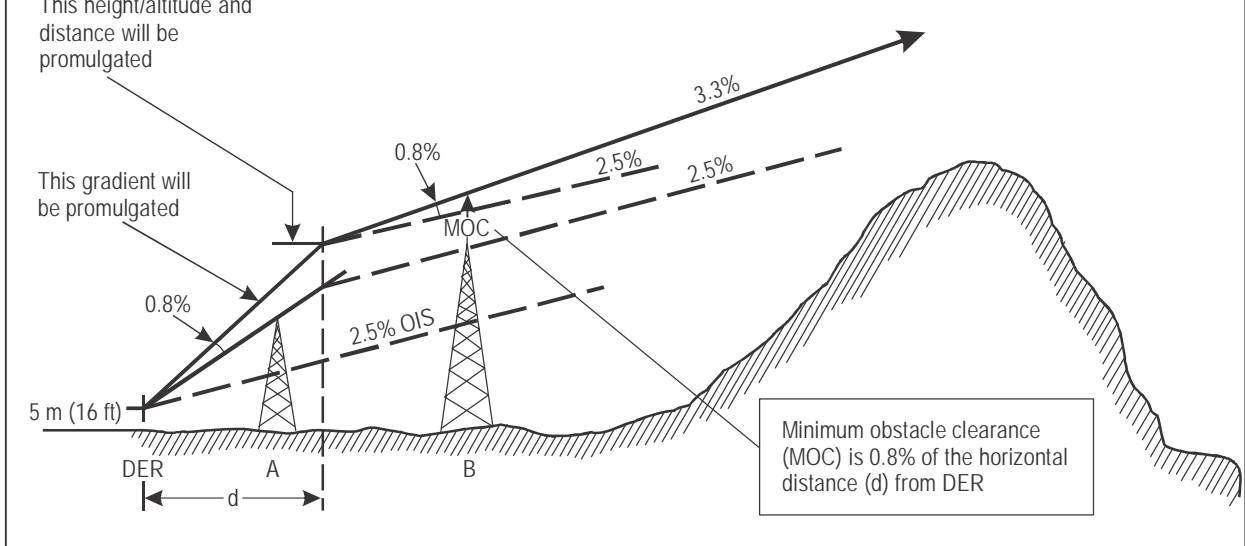

Figure I-3-5-1. Climb gradient reduction in departure

Chapter 6

SIMULTANEOUS OPERATIONS ON PARALLEL OR NEAR-PARALLEL INSTRUMENT RUNWAYS

Note.— *Guidance material is contained in the Manual on Simultaneous Operations on Parallel or Near-Parallel Instrument Runways (Doc 9643).*

6.1 INSTRUMENT DEPARTURES FROM PARALLEL RUNWAYS

When it is intended to use two instrument departure procedures from parallel runways simultaneously, the nominal departure tracks shall diverge by at least 15 degrees immediately after take-off (see Chapter 3, “Departure routes”).

6.2 SEGREGATED OPERATIONS ON PARALLEL RUNWAYS

When it is intended to use an instrument departure procedure and an instrument approach procedure in the same direction on parallel runways simultaneously, the nominal tracks of the departure procedure and of the missed approach procedure shall diverge by at least 30 degrees as soon as practicable (see Part II, Section 1, Chapter 1, “ILS”).

Section 4

ARRIVAL AND APPROACH PROCEDURES

Chapter 1

GENERAL CRITERIA FOR APPROACH/ARRIVAL PROCEDURES

1.1 SCOPE

Section 4 contains criteria common to all types of instrument arrival and approach procedures. Criteria which apply to specific types of facilities, such as ILS, are located in the chapters which deal with these kinds of guidance. Criteria which are specific to their implementation, as well as additions and exceptions to the general criteria, can be found in Part II, “Conventional procedures”, and in Part III, “RNAV procedures and satellite-based procedures”. Criteria for helicopters to runways are found in Parts I, II and III. Criteria for helicopters to heliports are found in Part IV.

Where characteristics of radio facilities are provided in this document, they are intended solely for the construction of procedures, and they do not replace or supplement corresponding material in Annex 10.

1.2 PROCEDURE CONSTRUCTION

An instrument approach procedure may have five separate segments. They are the arrival, initial, intermediate, final and missed approach segments. In addition, an area for circling the aerodrome under visual conditions should be considered. The approach segments begin and end at designated fixes. However, under some circumstances certain segments may begin at specified points where no fixes are available (or necessary). For example, the final approach segment of a precision approach may originate at the point of intersection of the designated intermediate flight altitude/height with the nominal glide path; the intermediate segment may begin at the end of the inbound turn.

1.3 FIX NAMES

The fixes are named according to the segment they precede. For example, the intermediate segment begins at the intermediate fix. Where no fix is available, as mentioned above in 1.2, “Procedure construction”, the segments begin and end at specified points (e.g. the point where the glide path intersects the nominal intermediate altitude and the point where the glide path intersects the nominal DA/H). This document discusses the segments in the order in which the pilot would fly them in a complete procedure, that is from arrival through initial and intermediate to a final approach and, if necessary, the missed approach.

1.4 SEGMENT APPLICATION

Only those segments that are required by local conditions need be included in a procedure. In constructing the procedure, the final approach track should be identified first because it is the least flexible and most critical of all the segments. When the final approach has been determined, the other necessary segments should be blended with it to produce an orderly manoeuvring pattern which is responsive to the local traffic flow. See Figure I-4-1-1.

1.5 PROCEDURE ALTITUDE/HEIGHT

1.5.1 The aviation industry has identified that the majority of large aircraft accidents occur lined up with and within 19 km (10 NM) of the landing runway. To support the Controlled Flight Into Terrain (CFIT) prevention initiatives, instrument approach charts shall not only provide altitudes/heights to ensure appropriate obstacle clearance but also procedure altitudes/heights. Procedure altitudes/heights are intended to place the aircraft above any minimum altitude associated with obstacle clearance and to support a stabilized prescribed descent gradient/angle in the final segment.

1.5.2 All non-precision instrument approach procedures shall be developed to include not only the minimum altitudes/heights to ensure obstacle clearance, but also procedure altitudes/heights. Procedure altitudes/heights shall be developed to place the aircraft at altitudes/heights that would normally be flown to intercept and fly the prescribed descent gradient/angle in the final approach segment to a 15 m (50 ft) threshold crossing. In no case shall a procedure altitude/height be less than any OCA/H.

1.6 TRACK GUIDANCE

1.6.1 Track guidance should normally be provided for all phases of flight through the arrival, initial, intermediate, final and missed approach segments. When track guidance is provided, the appropriate segment shall lie within the established coverage of the navigation facility on which the track guidance is based.

1.6.2 When track guidance is not provided the obstacle clearance area shall be expanded as prescribed for dead reckoning (DR) segments in Chapter 3, “Initial approach segment” and in Appendix A to Chapter 3, “Initial approach using dead reckoning (DR)”. Terminal area surveillance radar (TAR), when available, may be used to provide vectors to the final approach (see Part II, Section 2, Chapter 6, “SRE”). En-route surveillance radar (RSR) may be used to provide track guidance through initial approach segments up to and including the intermediate fix. Criteria for the construction of areas for missed approaches without track guidance are provided in Chapter 6, “Missed approach segment”.

Note.— Detailed procedures regarding the use of primary radar in the approach control service are set forth in the PANS-ATM, Doc 4444, Procedures for Air Navigation Services — Air Traffic Management.

1.7 DESCENT GRADIENTS

1.7.1 Throughout the document, optimum and maximum descent gradients are specified. The optimum is the operationally preferred descent gradient. This should only be exceeded where alternative means of satisfying obstacle clearance requirements are impracticable. The maximum gradient shall not be exceeded. (See also Section 4, Chapter 9.)

1.7.2 Optimum and maximum descent gradients are specified depending on the type of procedure and the segment of the approach. At least in the case of the final approach segment for non-precision approach procedures and, preferably, also for other approach segments where appropriate, the descent gradient(s) used in the construction of the procedure shall be published.

1.8 CATEGORIES OF AIRCRAFT

1.8.1 Aircraft performance differences have a direct effect on the airspace and visibility required for manoeuvres such as circling approach, turning missed approach, final approach descent and manoeuvring to land (including base and procedure turns). The most significant factor in performance is speed. Accordingly, five categories of typical aircraft (see 1.8.4) have been established to provide a standardized basis for relating aircraft manoeuvrability to specific instrument approach procedures.

1.8.2 The criteria taken into consideration for the classification of aeroplanes by categories is the indicated airspeed at threshold (V_{at}) which is equal to the stall speed V_{so} multiplied by 1.3 or stall speed V_{s1g} multiplied by 1.23 in the landing configuration at the maximum certificated landing mass. If both V_{so} and V_{s1g} are available, the higher resulting V_{at} shall be used.

1.8.3 The landing configuration which is to be taken into consideration shall be defined by the operator or by the aeroplane manufacturer.

1.8.4 Aircraft categories will be referred to throughout this document by their letter designations as follows:

- Category A — less than 169 km/h (91 kt) indicated airspeed (IAS)
- Category B — 169 km/h (91 kt) or more but less than 224 km/h (121 kt) IAS
- Category C — 224 km/h (121 kt) or more but less than 261 km/h (141 kt) IAS
- Category D — 261 km/h (141 kt) or more but less than 307 km/h (166 kt) IAS
- Category E — 307 km/h (166 kt) or more but less than 391 km/h (211 kt) IAS
- Category H — see 1.8.8, “Helicopters”.

1.8.5 The ranges of speeds (IAS) in Tables I-4-1-1 and I-4-1-2 are to be used in calculating procedures. For conversion of these speeds to TAS, see Part I, Section 1, Appendix to Chapter 1.

1.8.6 *Permanent change of category (maximum landing mass).* An operator may impose a permanent, lower, landing mass, and use of this mass for determining V_{at} if approved by the State of the Operator. The category defined for a given aeroplane shall be a permanent value and thus independent of changing day-to-day operations.

1.8.7 *Restrictions on category and IAS.* Where airspace requirements are critical for a specific category of aircraft, procedures may be based on lower speed category aircraft, provided use of the procedure is restricted to those categories. Alternatively the procedure may be designated as limited to a specific maximum IAS for a particular segment without reference to category.

1.8.8 Helicopters

- a) The stall speed method of calculating aircraft category does not apply to helicopters. Where helicopters are operated as aeroplanes, the procedure may be classified as Category A. However, specific procedures may be developed for helicopters and these shall be clearly designated “H”. Category H procedures shall not be promulgated on the same instrument approach chart (IAC) as joint helicopter/aeroplane procedures.
- b) Helicopter-only procedures should be designed using most of the same conventional techniques and practices as those pertaining to Category A aeroplanes. Some criteria such as minimum or maximum airspeed, descent gradients, and missed approach/departure climb gradients may be different, but the principles are the same.

- c) The specifications for Category A aeroplane procedure design apply equally to helicopters, except as specifically modified herein. The criteria that are changed for helicopter-only procedures are appropriately indicated throughout the text.

1.8.9 For precision approach procedures, the dimensions of the aircraft are also a factor for the calculation of the OCH. For Category D_L aircraft, additional OCA/H is provided, when necessary, to take into account the specific dimensions of these aircraft (see Part II, Section 1, Chapters 1 and 3 and Part III, Section 3, Chapter 6 (GBAS Cat I)).

Table I-4-1-1. Speeds (IAS) for procedure calculations in kilometres per hour (km/h)

Aircraft category	V_{at}	Range of speeds for initial approach	Range of final approach speeds	Max speeds for visual manoeuvring (circling)	Max speeds for missed approach	
					Intermediate	Final
A	<169	165/280(205*)	130/185	185	185	205
B	169/223	220/335(260*)	155/240	250	240	280
C	224/260	295/445	215/295	335	295	445
D	261/306	345/465	240/345	380	345	490
E	307/390	345/467	285/425	445	425	510
H	N/A	130/220**	110/165***	N/A	165	165
Cat H (PinS)***	N/A	130/220	110/165	N/A	130 or 165	130 or 165

V_{at} Speed at threshold based on 1.3 times stall speed V_{so} or 1.23 times stall speed V_{slg} in the landing configuration at maximum certificated landing mass. (Not applicable to helicopters.)

* Maximum speed for reversal and racetrack procedures.

** Maximum speed for reversal and racetrack procedures up to and including 6 000 ft is 185 km/h and maximum speed for reversal and racetrack procedures above 6 000 ft is 205 km/h.

*** Helicopter point-in-space procedures based on GNSS may be designed using maximum speeds of 220 km/h for initial and intermediate segments and 165 km/h on final and missed approach segments or 165 km/h for initial and intermediate segments and 130 km/h on final and missed approach depending on the operational need. Refer to Part IV, Chapter 2.

Note.— The V_{at} speeds given in column 2 of this table are converted exactly from those in Table I-4-1-2, since they determine the category of aircraft. The speeds given in the remaining columns are converted and rounded to the nearest multiple of five for operational reasons and from the standpoint of operational safety are considered to be equivalent.

Table I-4-1-2. Speeds (IAS) for procedure calculations in knots (kt)

Aircraft category	V_{at}	Range of speeds for initial approach	Range of final approach speeds	Max speeds for visual manoeuvring (circling)	Max speeds for missed approach	
					Intermediate	Final
A	<91	90/150(110*)	70/100	100	100	110
B	91/120	120/180(140*)	85/130	135	130	150
C	121/140	160/240	115/160	180	160	240
D	141/165	185/250	130/185	205	185	265
E	166/210	185/250	155/230	240	230	275
H	N/A	70/120**	60/90***	N/A	90	90
Cat H (PinS)***	N/A	70/120	60/90	NA	70 or 90	70 or 90

V_{at} Speed at threshold based on 1.3 times stall speed V_{so} or 1.23 times stall speed V_{slg} in the landing configuration at maximum certificated landing mass. (Not applicable to helicopters.)

* Maximum speed for reversal and racetrack procedures.

** Maximum speed for reversal and racetrack procedures up to and including 6 000 ft is 100 kt and maximum speed for reversal and racetrack procedures above 6 000 ft is 110 kt.

*** Helicopter point-in-space procedures based on GNSS may be designed using maximum speeds of 120 KIAS for initial and intermediate segments and 90 KIAS on final and missed approach segments or 90 KIAS for initial and intermediate segments and 70 KIAS on final and missed approach depending on the operational need. Refer to Part IV, Chapter 2.

Note.— The V_{at} speeds given in column 2 of Table I-4-1-1 are converted exactly from those in this table, since they determine the category of aircraft. The speeds given in the remaining columns are converted and rounded to the nearest multiple of five for operational reasons and from the standpoint of operational safety are considered to be equivalent.

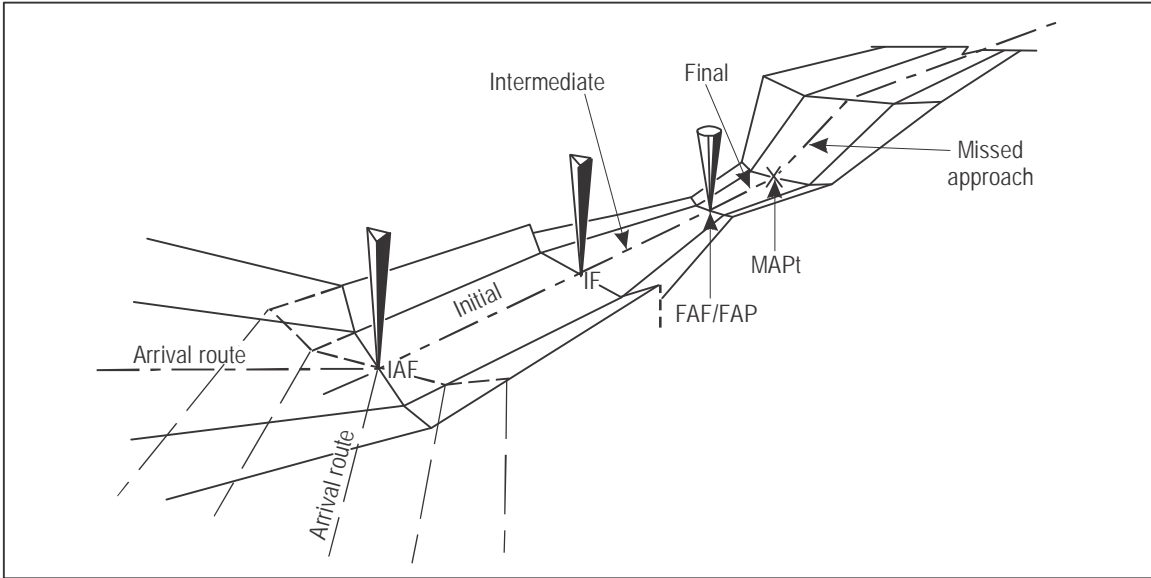

Figure I-4-1-1. Segment of instrument approach

Chapter 2

ARRIVAL SEGMENT

2.1 STANDARD INSTRUMENT ARRIVALS

2.1.1 General

This section contains criteria applicable to all standard instrument arrivals.

2.1.1.1 In some cases it is necessary to designate arrival routes from the en-route structure to the initial approach fix. Only those routes which provide an operational advantage shall be established and published. These should take local air traffic flow into consideration. The length of the arrival route shall not exceed the operational service range of the facilities which provide navigation guidance.

2.1.1.2 Standard instrument arrival routes (STARs) should be simple and easily understood and only those navigation facilities, fixes or waypoints essential to define the flight path of an aircraft and for Air Traffic Services (ATS) purposes will be included in the procedure.

2.1.1.3 A STAR should accommodate as many aircraft categories as possible.

2.1.1.4 A STAR should begin at a fix, e.g. radio navigation facility, intersection, distance measuring equipment (DME) fix or waypoint.

2.1.1.5 A STAR should permit transition from the en-route phase to the approach phase by linking a significant point normally on an ATS route with a point from which an instrument approach procedure is initiated.

2.1.1.6 A STAR should be designed to permit aircraft to navigate along the routes reducing the need for radar vectoring.

2.1.1.7 A STAR may serve one or more airports within a terminal area.

2.1.1.8 Procedure design should consider the environmental and efficiency advantages afforded by implementation of a continuous descent operation (CDO). Airspeed and altitude/level restrictions, if any, should be included. These should take into account the operational capabilities of the aircraft category involved, in consultation with the operators.

Note.— The Continuous Descent Operations (CDO) Manual (Doc 9931) provides guidance on implementing CDO and balancing CDO within the context of other ATM operations.

2.1.1.9 Whenever possible, STARs should be designed with DME fixes or waypoints instead of intersections.

Note 1.— Material relating to the principles governing the identification of standard arrival routes and associated procedures are contained in Annex 11, Appendix 3.

Note 2.— Material relating to the publication of the Standard Arrival Chart — Instrument (STAR) — ICAO is contained in Annex 4, Chapter 10.

2.1.1.10 A DME arc may provide track guidance for all or a portion of an arrival route. The minimum arc radius shall be 18.5 km (10.0 NM).

An arc may join a straight track at or before the initial approach fix. In this case, the angle of intersection of the arc and the track should not exceed 120°.

When the angle exceeds 70°, a lead radial which provides at least a distance “d” of lead shall be identified to assist in leading the turn ($d = r \cdot \tan \frac{(\alpha)}{2}$; r = radius of turn; α = angle of turn).

2.1.2 Area construction

2.1.2.1 Arrival routes 46 km or longer (25 NM)

When the length of the arrival route is greater than or equal to 46 km (25 NM), en-route criteria apply to the 46 km (25 NM) prior to the initial approach fix (IAF). The area width decreases from 46 km (25 NM) with a convergence angle of 30° each side of the axis, until reaching the width determined by the initial approach criteria. See Figure I-4-2-1.

2.1.2.2 Arrival routes less than 46 km (25 NM)

When the length of the arrival route is less than 46 km (25 NM), the area width decreases from the beginning of the arrival route with a convergence angle of 30° each side of the axis, until reaching the width determined by the initial approach criteria. See Figure I-4-2-2.

2.1.2.3 Turn protection

Turns will be protected by using:

- a) en-route criteria for distances greater than 46 km (25 NM) from the IAF; and
- b) initial approach criteria for distances of 46 km (25 NM) or less from the IAF.

2.1.2.4 Arrival based on a DME arc

In case of an arrival based on a DME arc, 2.1.2.1 and 2.1.2.2 apply with the following exceptions:

- a) the distance is measured along the DME arc; and
- b) the tapering is over a distance of 9.6 km (5.2 NM), measured along the DME arc.

The construction method is as follows. From the centre of the DME arc (point O), draw lines OA and OB which intersect the limits at A1, A2, A3, A4 and B1, B2, B3, B4. Then, draw lines joining corresponding points A to B. See Figures I-4-2-3 and I-4-2-4.

2.1.2.5 GNSS receivers

2.1.2.5.1 In addition to the general arrival criteria, the following criteria apply. Cross-track tolerance (XTT), along-track tolerance (ATT) and area semi-width for GNSS receivers are determined according to the formulae defined in Part III, Section 1, Chapter 2, 2.5, “XTT, ATT and area semi-width”.

2.1.2.5.2 The area width tapers at an angle of 30° each side of the axis, perpendicular to the point where the 30 NM (56 km) arc from the aerodrome reference point (ARP) intercepts the nominal track. Contrary to the general arrival criteria, the en-route width shall be used when more than 30 NM (56 km) from the ARP. See Figures I-4-2-5 and I-4-2-6.

2.1.3 Obstacle clearance

The obstacle clearance in the primary area shall be a minimum of 300 m (984 ft). In the secondary area 300 m (984 ft) of obstacle clearance shall be provided at the inner edge, reducing linearly to zero at the outer edge. See Figure I-2-1-1 in Chapter 1. For calculating obstacle clearance at a given point see Section 2, Chapter 1, 1.3, “Obstacle clearance”.

2.1.4 Procedure altitude/height

The procedure altitude/height shall not be less than the MOCA and shall be developed in coordination with air traffic control requirements. The arrival segment procedure altitude/height may be established to allow the aircraft to intercept the prescribed final approach segment descent gradient/angle from within the intermediate segment.

2.2 OMNIDIRECTIONAL OR SECTOR ARRIVALS

Omnidirectional or sector arrivals can be provided taking into account the minimum sector altitudes (MSA) (see Chapter 8, “Minimum sector altitudes”), or terminal arrival altitudes (TAA) (see Part III, Section 2, Chapter 4, “Terminal arrival altitude (TAA)”).

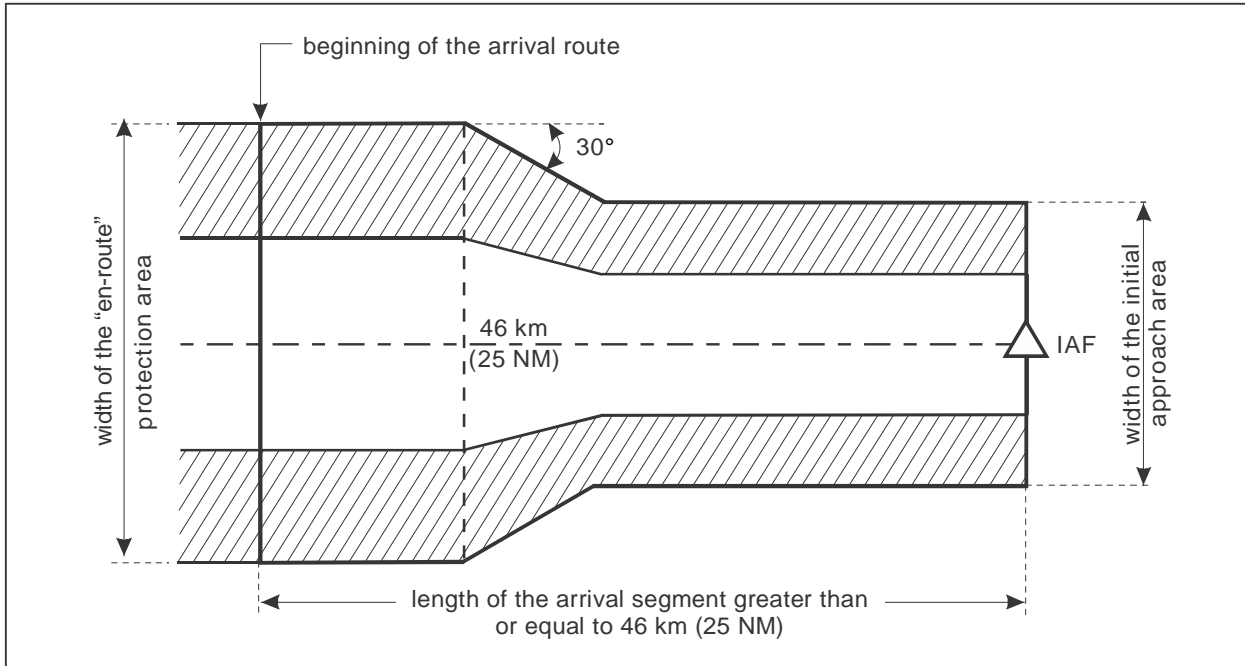

Figure I-4-2-1. Arrival segment — protection area (length of the arrival segment greater than or equal to 46 km (25 NM))

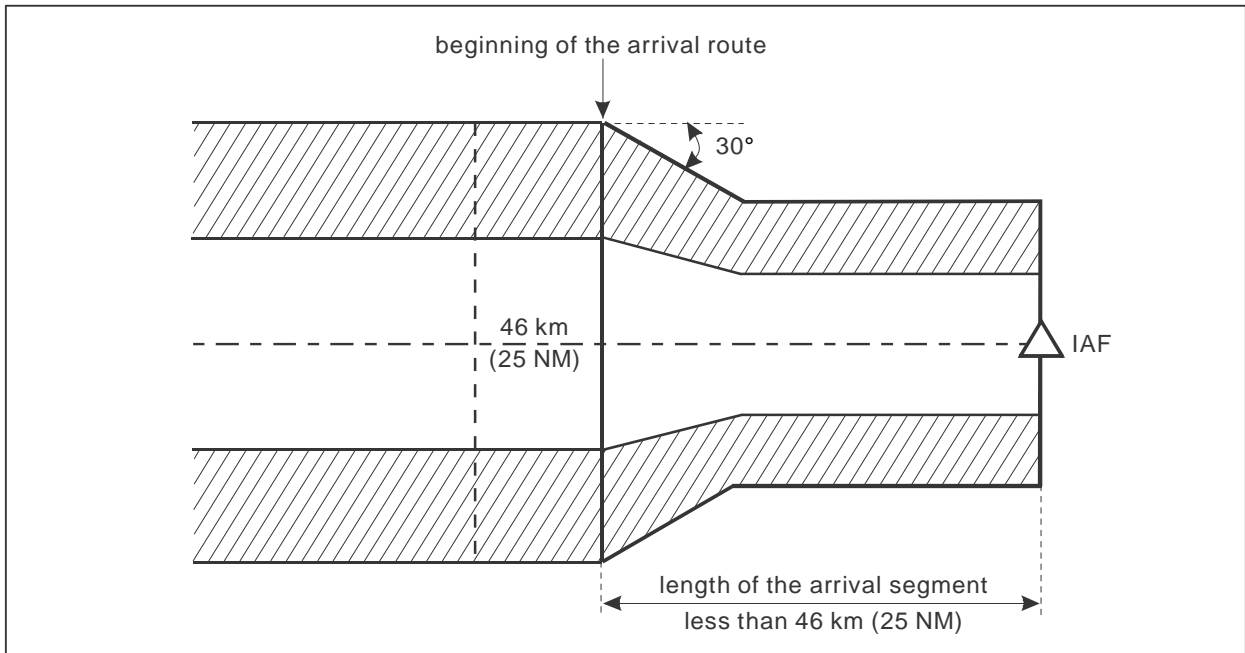

Figure I-4-2-2. Arrival segment — protection area (length of the arrival segment less than 46 km (25 NM))

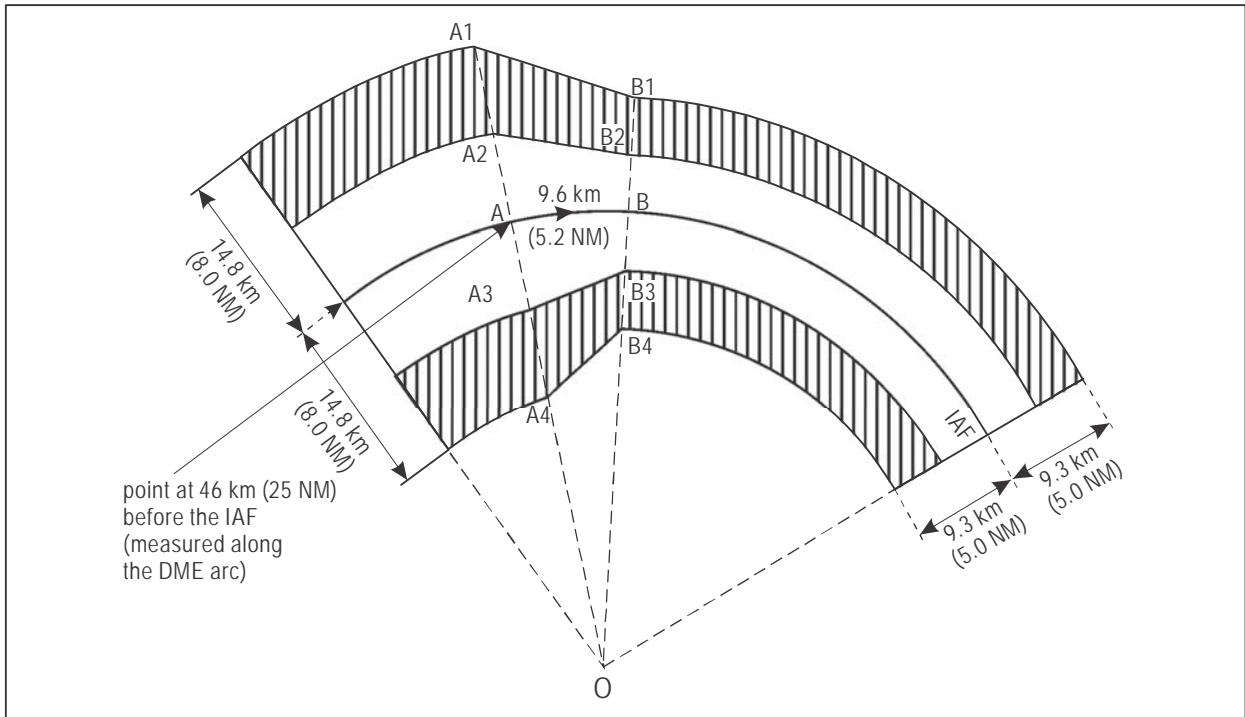

Figure I-4-2-3. DME arc — length of the arrival segment greater than or equal to 46 km (25 NM)

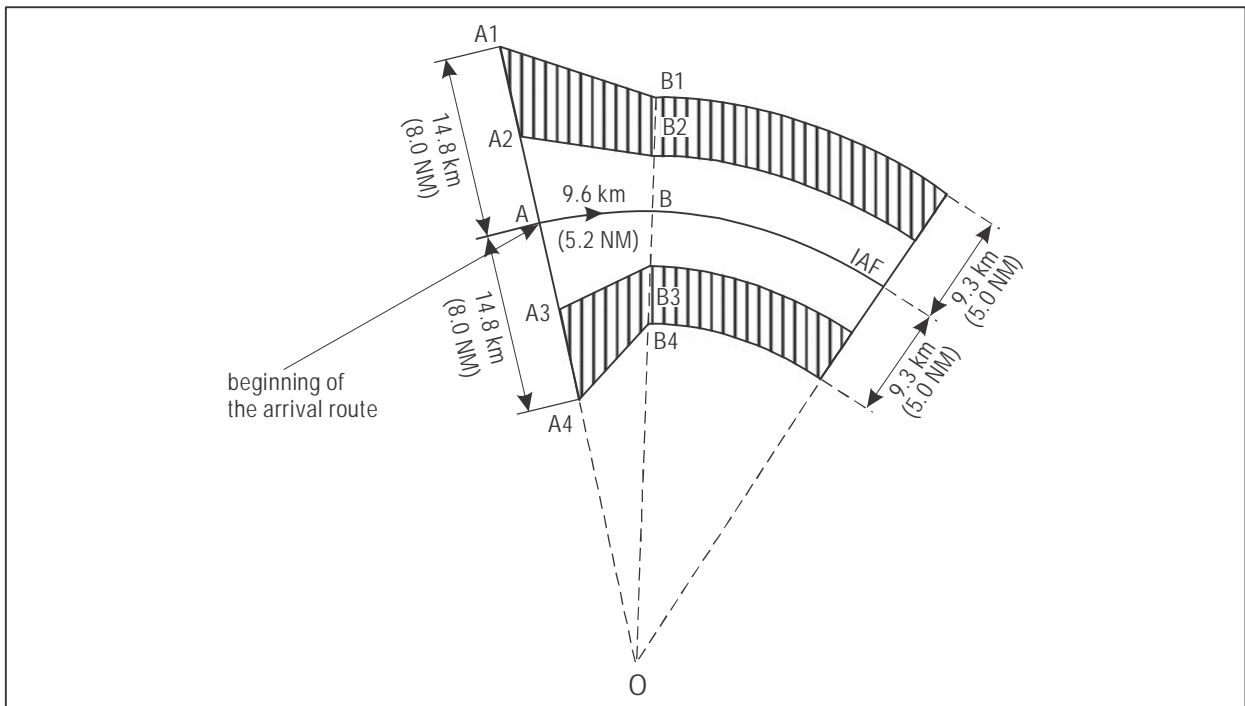

Figure I-4-2-4. DME arc — length of the arrival segment less than 46 km (25 NM)

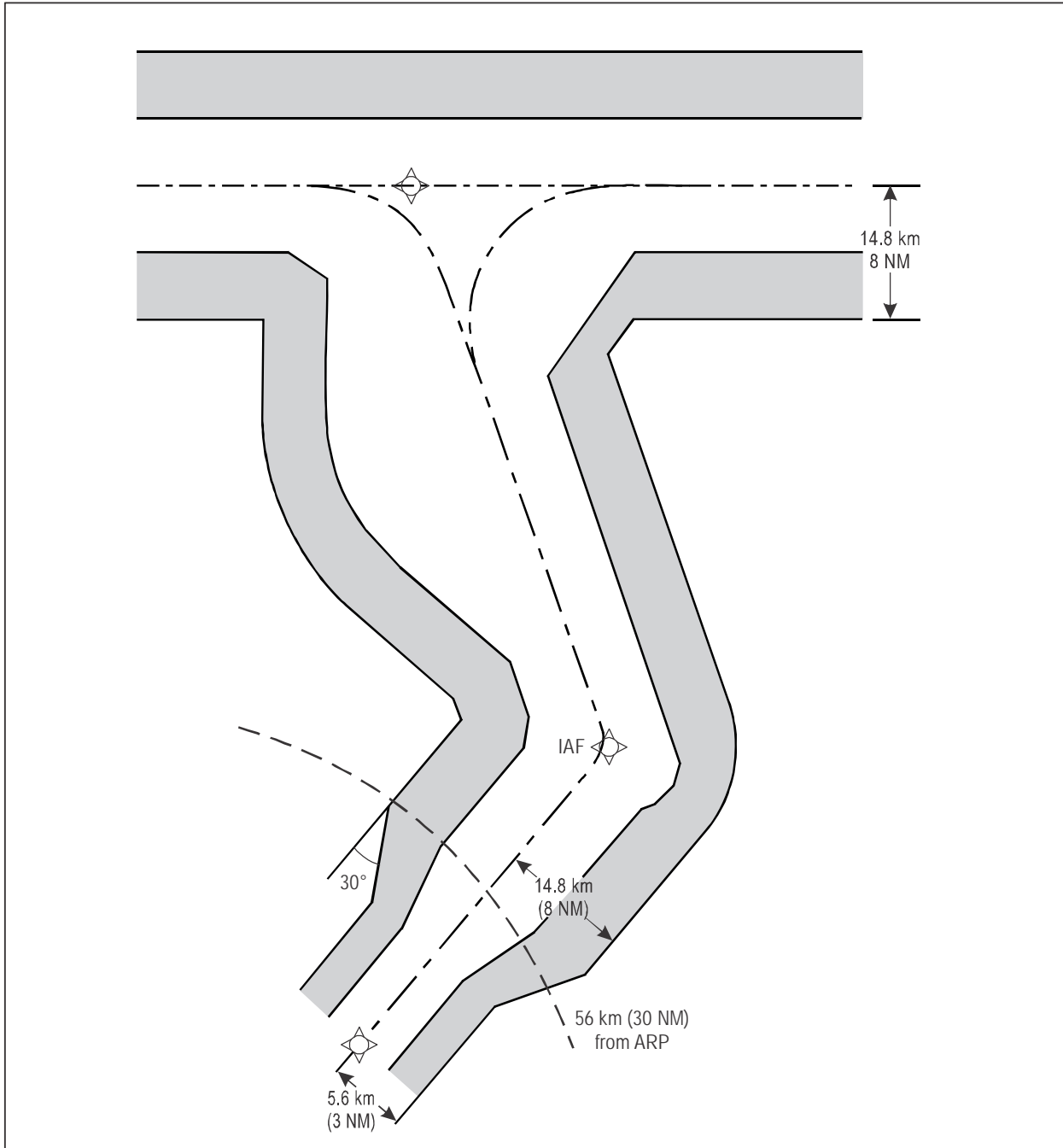

Figure I-4-2-5. GNSS arrival criteria, IAF beyond 56 km (30 NM) ARP: 14.8 km (8 NM) 1/2 AW prior to 56 km (30 NM) from ARP then 5.6 km (3 NM) 1/2 AW

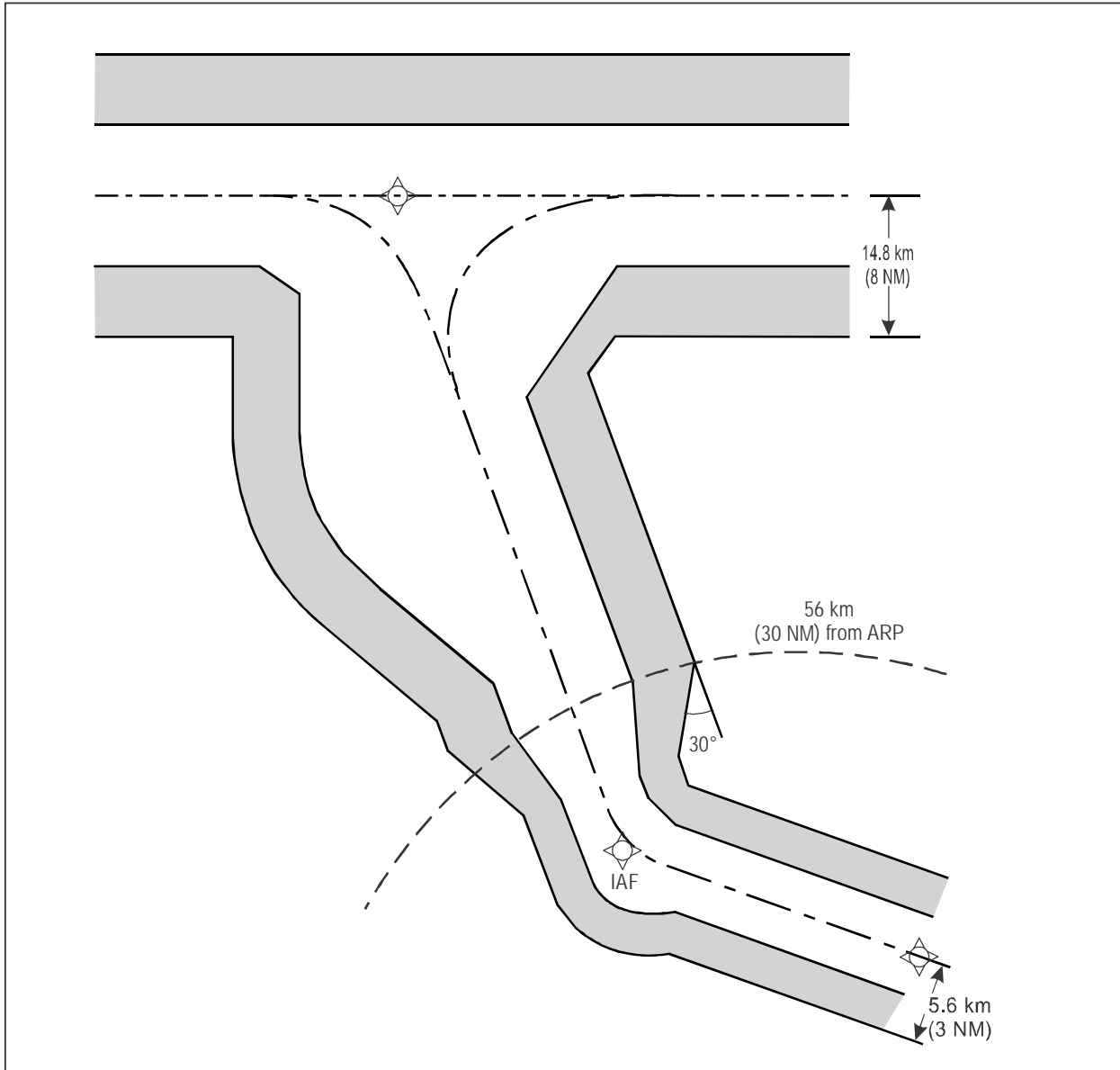

Figure I-4-2-6. GNSS arrival criteria, IAF within 56 km (30 NM) ARP: 14.8 km (8 NM) $\frac{1}{2}$ AW prior to 56 km (30 NM) from ARP then 5.6 km (3 NM) $\frac{1}{2}$ AW

Chapter 3

INITIAL APPROACH SEGMENT

3.1 GENERAL

3.1.1 The initial approach segment starts at the initial approach fix (IAF). In the initial approach the aircraft is manoeuvring to enter the intermediate segment. When the intermediate fix (IF) is part of the en-route structure, it may not be necessary to designate an initial approach segment. In this case the instrument approach procedure begins at the intermediate fix and intermediate segment criteria apply. An initial approach may be made along a VOR radial, NDB bearing, specified radar vector or a combination thereof. Where none of these is possible, a DME arc or a specified heading may be used.

3.1.2 Reversal and racetrack procedures as well as holding pattern descents are considered initial segments until the aircraft is established on the intermediate approach track. Where holding is required prior to entering the initial approach segment, the holding fix and initial approach fix should coincide. When this is not possible, the initial approach fix shall be located within the holding pattern on the inbound holding track.

3.1.3 Normally track guidance is required except that dead reckoning tracks may be used for distances not exceeding 19 km (10 NM). Although more than one initial approach may be established for a procedure, the number should be limited to that which is justified by traffic flow or other operational requirements.

3.2 ALTITUDE SELECTION

3.2.1 Minimum altitudes

Minimum altitudes in the initial approach segment shall be established in 100-ft or 50-m increments as appropriate. The altitude selected shall not be below the reversal or racetrack procedure altitude where such a procedure is required. In addition, altitudes specified in the initial approach segment must not be lower than any altitude specified for any portion of the intermediate or final approach segments.

3.2.2 Minimum altitudes for different aircraft categories

When different minimum altitudes are specified for different categories of aircraft, separate procedures shall be published.

3.2.3 Procedure altitude/height

All initial approach segments shall have procedure altitudes/heights established and published. Procedure altitudes/heights shall not be less than the MOCA and shall be developed in coordination with air traffic control requirements. The initial segment procedure altitude/height should be established to allow the aircraft to intercept the final approach segment descent gradient/angle from within the intermediate segment.

3.3 INITIAL APPROACH SEGMENTS (OTHER THAN RADAR VECTORS) UTILIZING STRAIGHT TRACKS AND DME ARCS

3.3.1 Tracks

The angle of intersection between the initial approach track and the intermediate track should not exceed 120°. When the angle exceeds 70°, a radial, bearing, radar vector or DME information providing at least 4 km (2 NM) of lead (Cat H, 1.9 km (1 NM)) shall be identified to assist in leading the turn onto the intermediate track (see Figure I-4-3-1). When the angle exceeds 120°, the use of a racetrack or reversal procedure or dead reckoning (DR) track should be considered. Criteria for such procedures are in 3.4, “Initial approach segment using a racetrack procedure”, 3.5, “Initial approach segment using a reversal procedure” and 3.3.3.3, “Area associated with dead reckoning (DR) track procedures”.

3.3.2 DME arcs

An arc may provide track guidance for all or for a portion of an initial approach. The minimum arc radius shall be 13 km (7 NM) (Cat H, 9.3 km (5 NM)). An arc may join a track at or before the intermediate fix. When joining a track, the angle of intersection of the arc and the track should not exceed 120°. When the angle exceeds 70°, a radial which provides at least 4 km (2 NM) (Cat H, 1.9 km (1 NM)) of lead shall be identified to assist in leading the turn onto the intermediate track.

3.3.3 Area

3.3.3.1 The initial approach segment has no standard length. The length shall be sufficient to permit the altitude change required by the procedure. The width is divided into:

- a) a primary area which extends laterally 4.6 km (2.5 NM) on each side of the track; and
- b) a secondary area which adds an additional 4.6 km (2.5 NM) on each side of the primary area.
(See Figure I-4-3-2.)

3.3.3.2 Area splay

Where, because of an operational requirement, any portion of the initial approach is more than 69 km (37 NM) from the VOR or 52 km (28 NM) from the NDB providing track guidance, the area will start splaying at these distances at an angle of 7.8° for VOR or 10.3° for NDB. Within this splayed area, the width of the primary area shall remain one half of the total width of the area. (See Figure I-4-3-3.) For calculating secondary area width at a given point, see Section 2, Chapter 1, 1.2.1, “Calculating secondary area width at a given point”.

Note.— See also Appendix B, “Reduction of the width of a straight initial approach area after the IAF and interface between straight initial approach area and reversal procedure areas” for possible reduction of the width of straight initial approach area.

3.3.3.3 Area associated with dead reckoning (DR) track procedures

Where DR track procedures are utilized, the area allocated for the turning portions of the dead reckoning segment shall be calculated to accommodate omnidirectional wind speed (w) derived by the following equation:

$w = (12h + 87)$ km/h, where h is altitude in thousands of metres; or

$w = (2h + 47)$ kt, where h is altitude in thousands of feet.

The area associated with the straight portion shall be expanded to account for the maximum drift from an unrecognized beam wind component of ± 56 km/h (± 30 kt) in addition to $\pm 5^\circ$ heading tolerance, since the pilot is expected to have appraised the wind speed within ± 30 kt (56 km/h) on the previous segments. The minimum length of the intermediate track being intercepted shall provide sufficient additional distance to accommodate these tolerances and the associated fix tolerances. See Appendix A, “Initial approach using dead reckoning (DR)”.

3.3.4 Obstacle clearance

The obstacle clearance in the initial approach primary area shall be a minimum of 300 m (984 ft). In the secondary area, 300 m (984 ft) of obstacle clearance shall be provided at the inner edge, reducing linearly to zero at the outer edge. See Figure I-2-1-1 in Section 2, Chapter 1. For calculating obstacle clearance at a given point, see Section 2, Chapter 1, 1.3, “Obstacle clearance”.

3.3.5 Descent gradient

The optimum descent gradient in the initial approach is 4.0 per cent (Cat H, 6.5 per cent). Where a higher descent gradient is necessary to avoid obstacles, the maximum permissible is 8.0 per cent (Cat H, 10 per cent or, if the initial approach speed is restricted to 165 km/h IAS (90 kt IAS), 13.2 per cent).

3.4 INITIAL APPROACH SEGMENT USING A RACETRACK PROCEDURE

3.4.1 General

Racetrack procedures are used where sufficient distance is not available in a straight segment to accommodate the required loss of altitude and when entry into a reversal procedure is not practical. Racetrack procedures may also be specified as an alternative to reversal procedures to increase operational flexibility.

3.4.2 Shape of a racetrack procedure

The racetrack procedure has the same shape as a holding pattern but with different operating speeds and outbound timing. The inbound track normally becomes the intermediate or final segment of the approach procedure.

3.4.3 Starting point

The racetrack procedure starts at a designated facility or fix.

3.4.4 Entry

3.4.4.1 Entry into a racetrack procedure shall be similar to entry procedures for holding patterns as specified in Part II, Section 4, Chapter 1, 2.1, with the following additional considerations:

- a) offset entry from Sector 2 shall limit the time on the 30° offset track to 1 min 30 s. After this time the pilot should turn to a heading parallel to the outbound track for the remainder of the outbound time. If the outbound time is only 1 min, the time on the 30° offset track shall be 1 min also; and
- b) parallel entry shall not return directly to the facility without first intercepting the inbound track (when proceeding onto the final approach segment).

3.4.4.2 *Restricted entry*

Where necessary to conserve airspace (or for other reasons), entry may be restricted to specific routes. When so restricted, the entry route(s) shall be specified in the procedure. Examples of restricted entries are shown in Appendix C.

3.4.5 **Outbound time**

3.4.5.1 The duration of the outbound flight of a racetrack procedure may be 1 to 3 minutes (specified in 1/2 min increments) to allow increased descent. This time may vary according to aircraft categories (see Tables I-4-1-1 and I-4-1-2 of Section 4, Chapter 1 in order to reduce the overall length of the protected area in cases where airspace is critical (see 3.4.5.2, “Timings for different categories of aircraft”). If airspace is critical and extension beyond 1 minute is not possible, the descent may involve more than one orbit in the racetrack according to descent/time relationship specified in 3.7 (Table I-4-3-1).

3.4.5.2 *Timings for different categories of aircraft*

Where different timings are specified for different categories of aircraft, separate procedures shall be published.

3.4.6 **Limitation of length of outbound track**

The length of the outbound track of a racetrack procedure may be limited by specifying a DME distance or a radial/bearing from a suitably located facility (see 3.6.6, “Use of DME or intersecting radial/bearing”).

3.5 **INITIAL APPROACH SEGMENT USING A REVERSAL PROCEDURE**

3.5.1 **General**

Reversal procedures are used to establish the aircraft inbound on an intermediate or final approach track at the desired altitude. There are two types of reversal procedure: procedure turns and base turns. Both of these consist of an outbound track followed by a turning manoeuvre which reverses direction onto the inbound track. Reversal procedures are used when:

- a) the initial approach is initiated from a facility (or fix in the case of a procedure turn) that is located on or near the aerodrome; or
- b) a turn of more than 70° would be required at the IF, and a radial, bearing, radar vector, DR track, or DME information is not available to assist in leading the turn on to the intermediate track; or

- c) a turn of more than 120° (90° for ILS, see Part II, Section 1, Chapter 1, 1.2.2, “Initial approach segment alignment” would be required at the IF.

Specifics of each reversal procedure are described below.

3.5.2 Starting point

The starting point for a base turn shall be a facility. The starting point for a procedure turn shall be a facility or a fix. The reversal procedure may be preceded by manoeuvring in a suitably located holding pattern.

3.5.3 Entry

Entry into a reversal procedure should be from a track within $\pm 30^\circ$ of the outbound track (see Figures I-4-3-4 and I-4-3-5). Where entry is desired from tracks outside these limits, suitably protected airspace must be provided to allow the pilot to manoeuvre onto the outbound track. This manoeuvring will be in accordance with the entry procedures associated with a suitably located holding pattern, which must be shown on the approach chart (see Figure I-4-3-6).

3.5.4 Types of reversal procedures

The types of procedures permitted are illustrated in Figure I-4-3-7 and are described as follows.

3.5.4.1 *45°/180° procedure turns* start at a facility or fix and consist of:

- a) a straight leg with track guidance; this straight leg may be timed or may be limited by a radial or DME distance (see 3.5.5, “Outbound time” and 3.5.6, “Limitation of length of outbound tracks”);
- b) a 45° turn;
- c) a straight leg without track guidance. This straight leg is timed; it shall be:
 - 1) 1 minute from the start of the turn for Categories A, B and H aircraft; and
 - 2) 1 minute and 15 seconds from the start of the turn for Categories C, D and E aircraft; and
- d) a 180° turn in the opposite direction to intercept the inbound track.

3.5.4.2 *80°/260° procedure turns* start at a facility or fix and consist of:

- a) a straight leg with track guidance; this straight leg may be timed or may be limited by a radial or DME distance (see 3.5.5, “Outbound time” and 3.5.6, “Limitation of length of outbound tracks”);
- b) an 80° turn; and
- c) a 260° turn in the opposite direction to intercept the inbound track.

CAUTION: The 45°/180° and the 80°/260° procedure turns are alternatives to each other and the protection area should be constructed to accommodate both procedures unless one is specifically excluded (see 3.6.4).

3.5.4.3 *Base turns* consist of a specified outbound track which may be timed or may be limited by a radial or DME distance (see 3.5.5, “Outbound time” and 3.5.6, “Limitation of length of outbound tracks”), followed by a turn to intercept the inbound track. The divergence between the outbound and inbound track (ϕ) shall be calculated as follows:

a) for true airspeed (TAS) less than or equal to 315 km/h (170 kt): $\phi = 36/t$; and

b) for TAS exceeding 315 km/h (170 kt):

$$\phi = (0.116 \times \text{TAS})/t \text{ where TAS is in km/h}$$

$$\phi = (0.215 \times \text{TAS})/t \text{ where TAS is in kt}$$

where t is the time in minutes specified for the outbound leg, and TAS corresponds to the maximum indicated airspeed (IAS) specified for the procedure.

3.5.4.4 *Outbound tracks or timing for different aircraft categories.* Where different outbound tracks or timing are specified for different categories of aircraft, separate procedures shall be published.

3.5.5 Outbound time

Where appropriate, outbound time of reversal procedures shall be specified. Normally it should be specified as a time between 1 and 3 minutes using 1/2 minute increments. It may be varied in accordance with aircraft categories (see Tables I-4-1-1 and I-4-1-2 of Section 4, Chapter 1) in order to reduce the overall length of the protected area in cases where airspace is critical. Extension of the outbound timing beyond 3 minutes must only be considered in exceptional circumstances.

3.5.6 Limitation of length of outbound tracks

The length of the outbound track of a reversal procedure may be limited by specifying a DME distance or a radial/bearing from a suitably located facility (see 3.6.6, “Use of DME or intersecting radial/bearing”).

3.6 RACETRACK AND REVERSAL PROCEDURE AREAS

3.6.1 General

The areas required to accommodate both the racetrack and reversal procedures described in 3.4 and 3.5 shall be based on the application of the area parameters specified in 3.6.2 below. These may be applied either on an additive tolerance basis or using statistical methods.

3.6.2 Area parameters

The parameters on which both racetrack and reversal procedures are based are:

- a) *altitude (h)*: the specified altitude for which the area is designed;
- b) *temperature*: International standard atmosphere (ISA) for the specified altitude plus 15°C;
- c) *indicated airspeed (IAS)*: the highest procedural speed category for which the area is designed (see Tables I-4-1-1 and I-4-1-2 of Section 4, Chapter 1);

- d) *true airspeed (TAS)*: the IAS in c) above adjusted for altitude a) and temperature b);
- e) *wind speed (w)*: omnidirectional for the specified altitude h;

$w = (12 h + 87) \text{ km/h}$ where h is in thousands of metres

$w = (2 h + 47) \text{ kt}$ where h is in thousands of feet *or*

provided adequate statistical data are available, the maximum 95 per cent probability omnidirectional wind may be used (see Part II, Section 4, Chapter 1, 1.3.6, “Wind velocity”);

- f) *average achieved bank angle*: 25° or the bank angle giving a turn rate of 3° per second, whichever is the lesser;

Note.— *If the TAS is greater than 315 km/h (170 kt), the bank angle will always be 25° .*

- g) *fix tolerance area*: as appropriate to the type of facility or fix and type of entry; and
- h) *flight technical tolerance* which is comprised of the following variables (see Figure I-4-3-8):
 - 1) outbound timing tolerance of ± 10 s;
 - 2) pilot reaction time of 0 to + 6 s;
 - 3) establishment of bank angle, + 5 s; and
 - 4) heading tolerance $\pm 5^\circ$.

3.6.3 Operational assumptions

The operational assumptions associated with procedure design criteria for racetrack and reversal procedures are:

- a) *start of outbound timing — racetrack procedures*:
 - 1) for racetrack procedures using a facility — outbound timing starts from abeam the facility or on attaining the appropriate outbound heading, whichever comes later; and
 - 2) for racetrack procedures using a fix — appropriate outbound timing starts from obtaining the outbound heading;
- b) *outbound track adjustment — racetrack procedures*. The outbound track for racetrack procedures will always be adjusted to avoid crossing the nominal inbound track before the final turn; and
- c) *pilot correction for wind effects*:
 - 1) for racetrack procedures, the area should be calculated and drawn for the fastest aircraft category to be accommodated. Although the area based on the slow speed (i.e. 165 km/h (90 kt)) aircraft in strong winds may in some places be larger than the area so constructed, it is considered that the normal operational adjustments made by pilots of such aircraft are such that the aircraft will be contained within the area; and
 - 2) for base and procedure turns, however, the area for 165 km/h (90 kt) should be checked.

3.6.4 Area construction

3.6.4.1 Statistical area construction

If statistical methods are used to combine the variables and then to extrapolate distributions to develop areas, the probability level associated with that extrapolation should meet an acceptable level of safety.

3.6.4.2 Additive tolerance area construction

A variety of methods may be used to construct areas. Whichever method is selected, the procedure design criteria specified in 3.5, “Initial approach segment using a reversal procedure”, and the area parameters specified in 3.6.2, “Area parameters”, apply. One additive tolerance method, the template tracing technique (TTT), is described in Appendix C.

Note.— For applications where airspace is not critical, a method of constructing a simplified rectangular area (based on the TTT areas) is also contained in Appendix C.

3.6.5 Area reduction

The area may be reduced under special circumstances. Methods of reduction include:

- a) reduction of the maximum speed(s) specified for the procedure. Speeds below the minimum value for initial approach in a given aircraft category shall not be specified (see Tables I-4-1-1 and I-4-1-2 of Section 4, Chapter 1). If procedures are developed which exclude specific aircraft categories due to speed, this must be stated explicitly;
- b) restricting use of the procedure to specified categories of aircraft;
- c) restricting procedure entry to specific track(s); and
- d) use of DME or radial/bearing to limit outbound track (see 3.6.6, “Use of DME or intersecting radial/bearing”).

3.6.6 Use of DME or intersecting radial/bearing

If a DME distance or an intersecting radial or bearing is used to limit the outbound leg, the area may be reduced by applying the appropriate adjustments described in Appendix C, in this case the limiting distance or radial/bearing shall allow adequate time for the descent specified. The distance on the outbound track is thereby limited by the timing or by reaching the limiting DME distance or radial/bearing, whichever occurs first.

3.6.7 Secondary areas

Secondary areas shall be added to the outer boundary of all areas calculated using the criteria in 3.6.4, “Area construction”. The width of the secondary area is 4.6 km (2.5 NM).

Note.— See Appendix B, “Reduction of the width of a straight initial approach area after the IAF and interface between straight initial approach area and reversal procedure areas” for possible reduction of secondary area width.

3.7 MAXIMUM DESCENT/NOMINAL OUTBOUND TIMING RELATIONSHIP FOR A REVERSAL OR RACETRACK PROCEDURE

3.7.1 General

Because the actual length of the track will vary, it is not possible to specify a descent gradient for the racetrack or reversal procedures. Instead, the maximum descents which can be specified on the outbound and inbound tracks of the procedure are listed in Table I-4-3-1 as a function of nominal outbound time.

Note.— Where a 45° procedure turn is specified, an additional 1 minute may be added to the nominal outbound time in calculating the maximum descent outbound.

Example: Reversal procedure with 2.5 minutes outbound track (Category A and B aircraft):

- a) maximum descent to be specified on outbound track = 612 m (2 010 ft); and
- b) maximum descent to be specified on inbound track = 500 m (1 638 ft).

3.7.2 Turns

In calculating maximum descents, no descent shall be considered as having taken place during turns.

3.8 OBSTACLE CLEARANCE

The prescribed minimum altitudes for either the racetrack or the reversal procedure shall not be less than 300 m (984 ft) above all obstacles within the appropriate primary areas. In the secondary area the minimum obstacle clearance shall be 300 m (984 ft) at the inner edge, reducing linearly to zero at the outer edge. See Chapter 1, 1.6, “Obstacle clearance”.

Table I-4-3-1. Maximum/minimum descent to be specified on a reversal or racetrack procedure

		<i>Maximum*</i>	<i>Minimum*</i>
Outbound track	Cat A/B	245 m/min (804 ft/min)	N/A
	Cat C/D/E/H	365 m/min (1 197 ft/min)	N/A
Inbound track	Cat A/B	200 m/min (655 ft/min)	120 m/min (394 ft/min)
	Cat H	230 m/min (755 ft/min)	N/A
	Cat C/D/E	305 m/min (1 000 ft/min)	180 m/min (590 ft/min)

* *Maximum/minimum descent for 1 minute nominal outbound time in m(ft). For maximum descent rates related to a final approach segment, see Chapter 5, 5.3.*

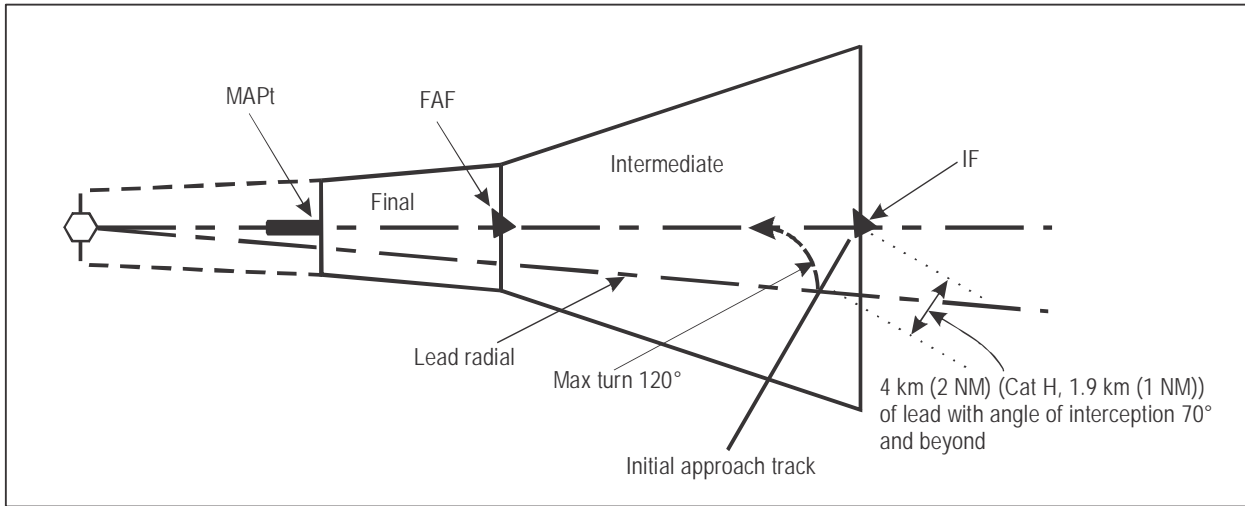

Figure I-4-3-1. Lead radial for turns greater than 70°

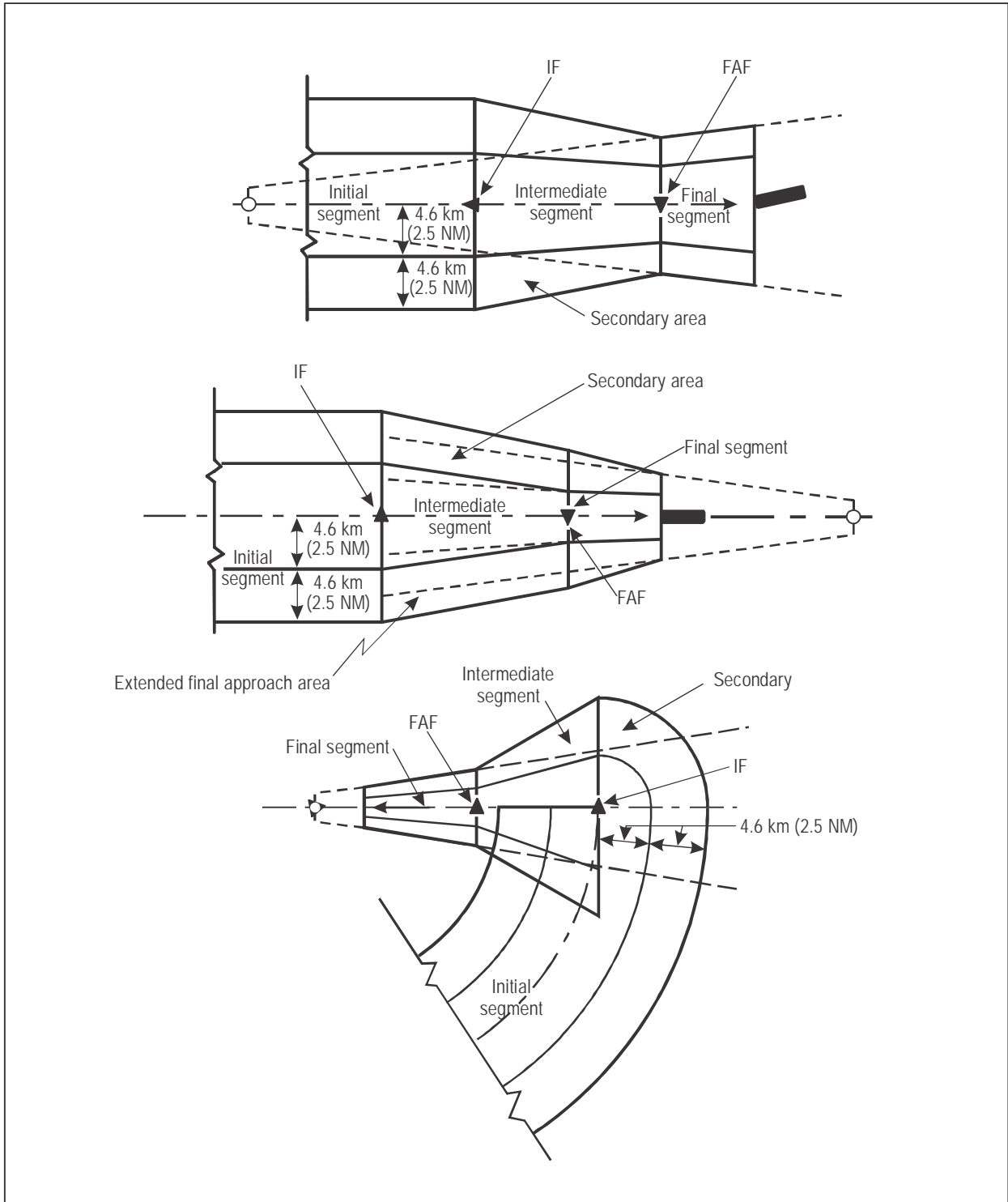

Figure I-4-3-2. Typical segments (plan view)

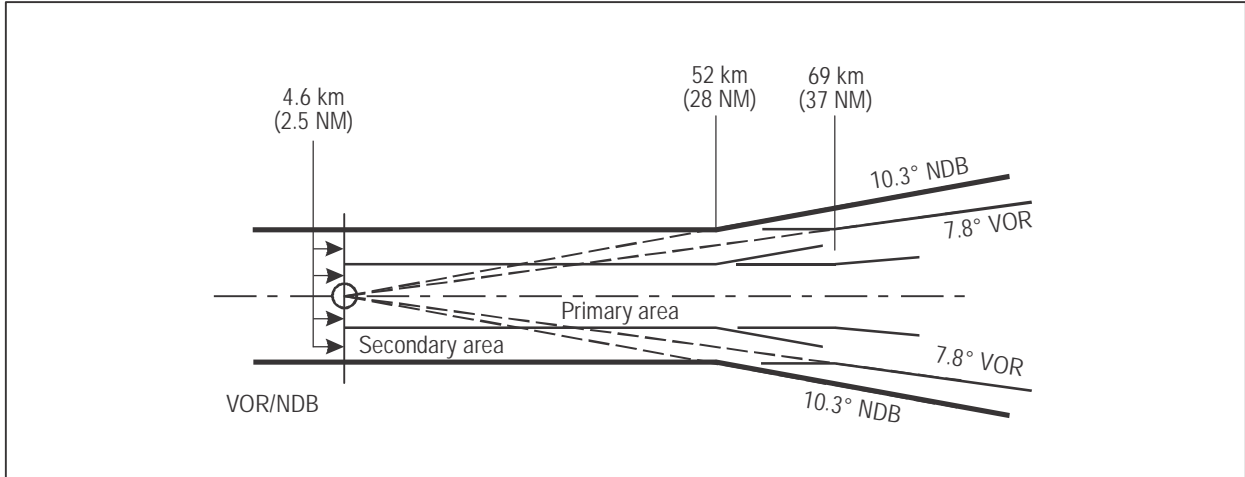

Figure I-4-3-3. Initial approach area utilizing straight tracks

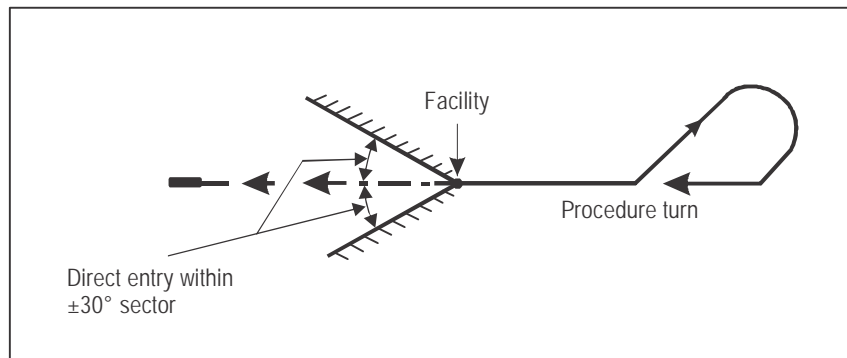

Figure I-4-3-4. Entry to procedure turn

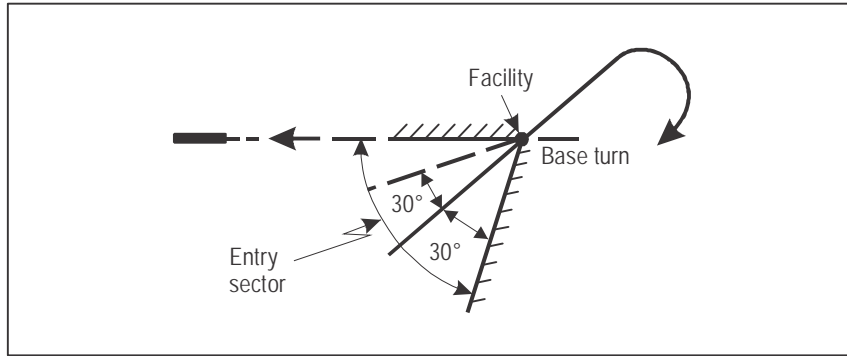

Figure I-4-3-5. Entry to base turn

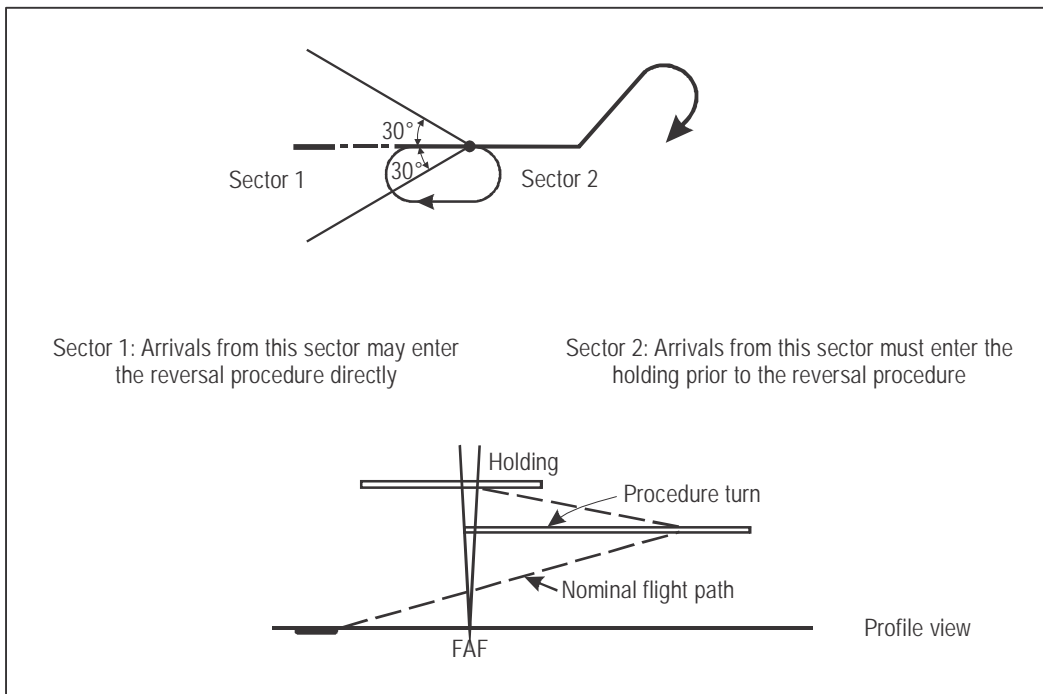

Figure I-4-3-6. Example of omnidirectional arrival using a holding procedure in association with a reversal procedure

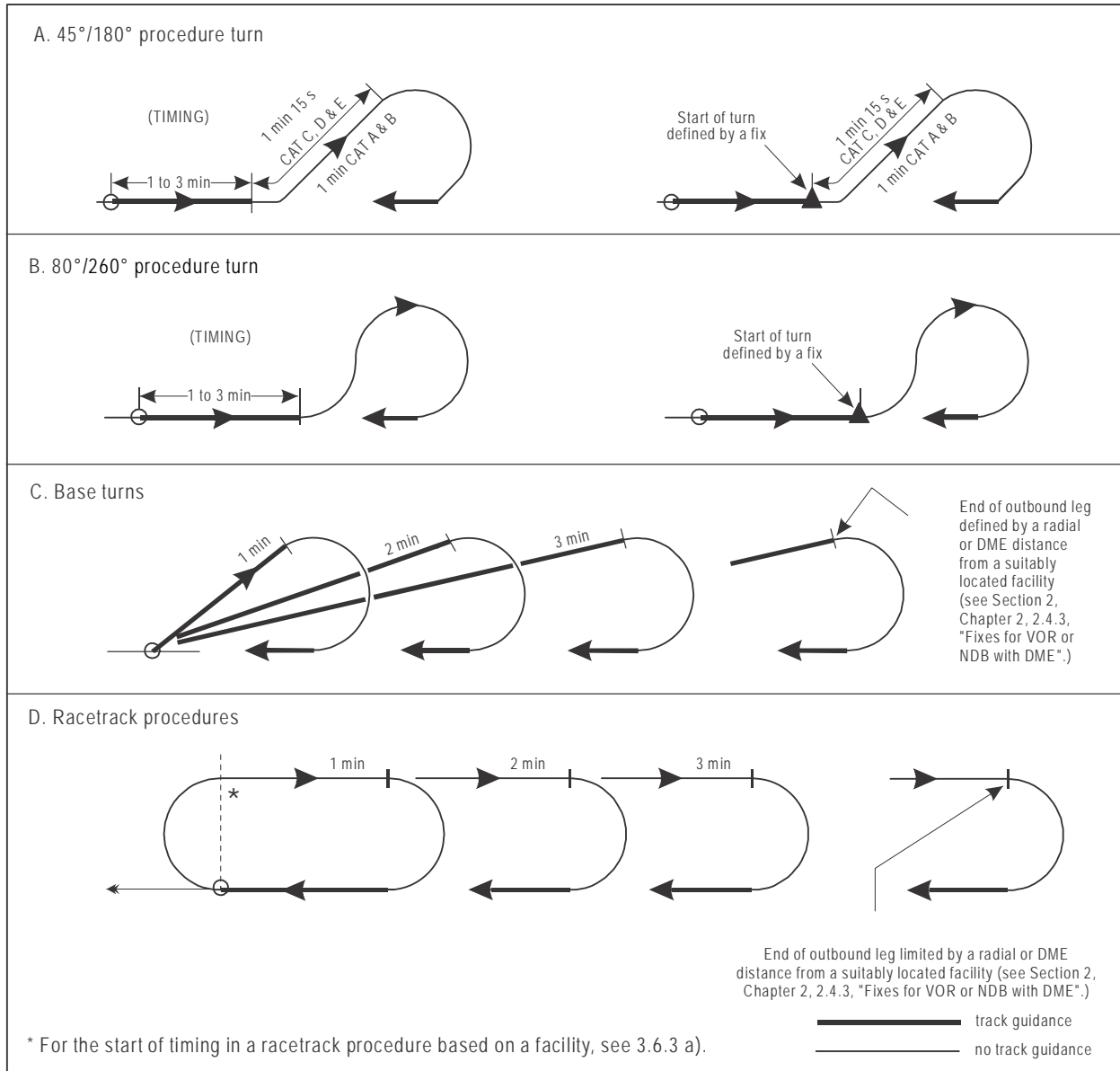

Figure I-4-3-7. Types of reversal and racetrack procedures

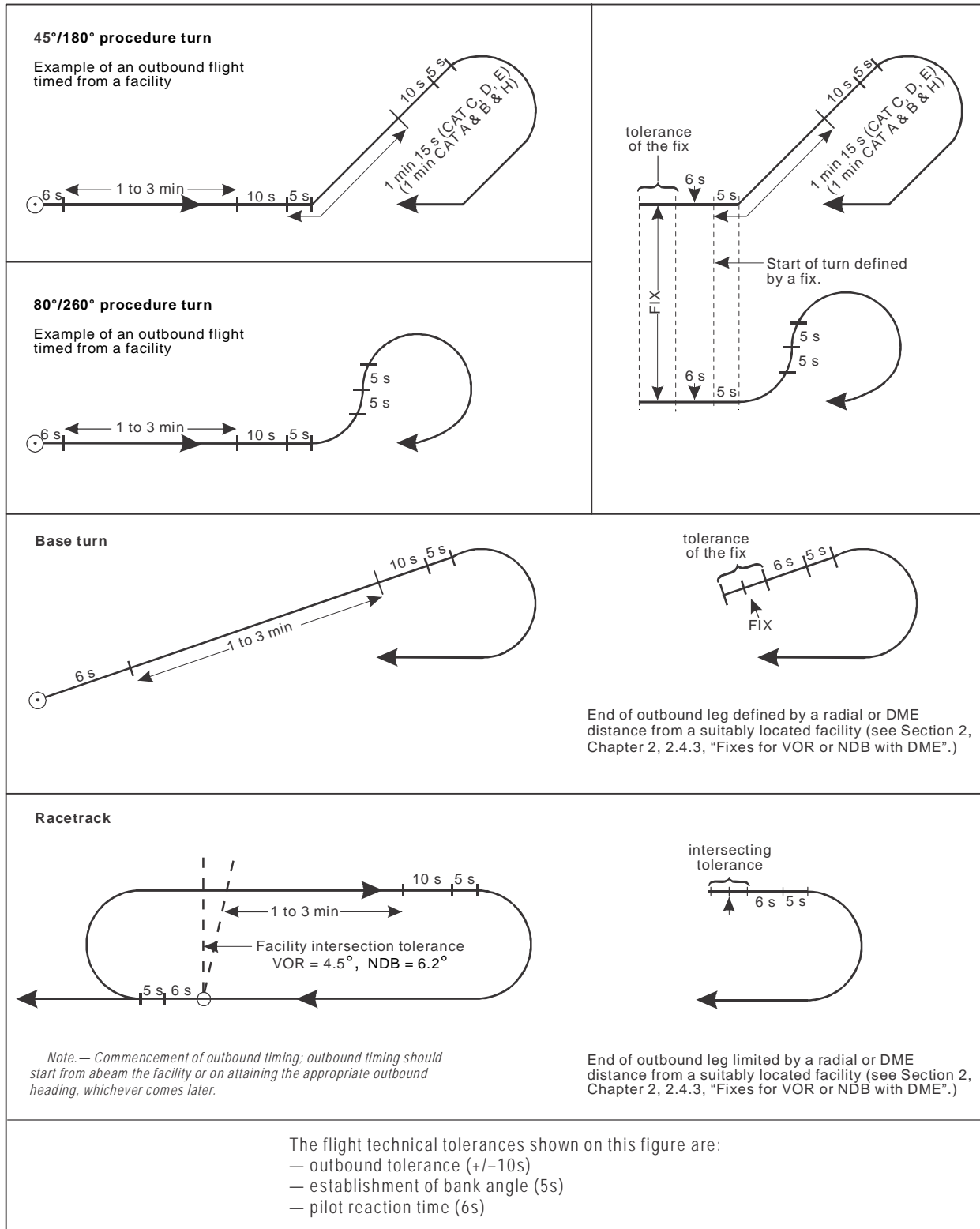

Figure I-4-3-8. Application of flight technical tolerance

Appendix A to Chapter 3

INITIAL APPROACH USING DEAD RECKONING (DR)

1. GENERAL

1.1 Purpose

1.1.1 A dead reckoning (DR) track procedure may be used to reduce the angle of turn onto the final approach track where such a turn would otherwise exceed the limits specified in Part II, Section 1, Chapter 1, 1.2.2, “Initial approach segment alignment”. Its main purposes are:

- a) to save time and airspace by avoiding a reversal manoeuvre;
- b) to provide pilots with a comfortable flight pattern. The chances of overshooting the final approach track in case of a suitably designed intercepting DR track are less than in the case of a large turn initiated by a lead radial; and
- c) to provide air traffic control (ATC) with flexibility by designing DR track segments of different length to accommodate two ranges of speeds. This will allow a slower aircraft followed by a faster one to be assigned to a shorter track to the advantage of both aircraft.

1.1.2 Several DR tracks may be designed using the criteria in this attachment. This allows ATC to vary the initial track of the aircraft under radar surveillance by assigning a track number to the aircraft. And if radar vectoring is required, this track will provide the ATC with a reference (on the radar scope) which shows the most appropriate way to proceed from the initial approach fix (IAF) to the final approach point (FAP).

1.2 Required navigation facilities

This type of procedure requires either two VORs or a VOR/DME to define the fix from which the DR track begins. Track guidance on final and intermediate approach may be provided either by VOR, NDB or localizer (LOC). Because this procedure is intended for use at major airports, it has been illustrated for the instrument landing system (ILS) case. When any portion of DR segment between the nominal position of start point and the localizer course lies outside of the service volume of the localizer, a homing facility close to the final approach track (for example at the airport) is required.

Note.— In case of non-precision approach, the areas shall be adapted to the type of facility providing guidance on final approach.

2. PARAMETERS

2.1 Aircraft speed

- Aircraft Categories A and B: Indicated airspeed (IAS) from 165 to 335 km/h (90 to 180 kt); and
- Aircraft Categories C, D and E: IAS from 335 to 465 km/h (180 to 250 kt).

The corresponding true airspeeds (TAS) are calculated taking into account the following factors:

- a) temperature: International standard atmosphere (ISA) + 15°C; and
- b) altitude: 1 500 m (5 000 ft) and 3 000 m (10 000 ft).

2.2 Wind speed

An omnidirectional wind shall be used. The wind speed (w) in km/h (kt) is determined by the formula:

$$w = (12 h + 87) \text{ km/h where } h \text{ is in thousands of metres}$$

$$w = (2 h + 47) \text{ kt where } h \text{ is in thousands of feet.}$$

However, for the straight part of the dead reckoning segment an omnidirectional wind of 56 km/h (30 kt) shall be taken into account. This assumes that the pilot is given the wind speed at the aerodrome and has appraised the wind within 56 km/h (30 kt) on the previous leg, the length of which shall be specified on approach charts.

2.3 Flight technical tolerances

- a) *Bank angle*. 25° or the angle corresponding to a rate of turn of 3° per second, whichever is the lesser.
- b) *Tolerances*:
 - 1) pilot reaction time: 0 to + 6 s;
 - 2) bank establishment time: + 5 s; and
 - 3) heading tolerance: ±5°.

2.4 Fix tolerances

These are established taking into account the accuracy of the facility used:

- a) VOR facility providing track guidance: ±5.2°;
- b) VOR intersecting facility: ±4.5°; and
- c) DME distance indications: 0.46 km (0.25 NM) + 1.25 per cent of the distance to the antenna.

2.5 Table of basic values

See Table I-4-3-App A-1.

3. TRACK CONSTRUCTION

3.1 General

3.1.1 *Types of procedures.* A distinction should be made between two types of procedures:

- a) the U-type procedures (see Figure I-4-3-App A-1) in which the turn preceding the dead reckoning segment and the turn joining the final approach track are made in the same direction; and
- b) the so-called S-type procedures (see Figure I-4-3-App A-2) in which these two turns are in opposite directions.

3.1.2 *Components of procedures.* These two procedures can be broken down as follows.

- a) *First leg of the initial approach.* This track is defined by a VOR radial. In order to limit the tolerance area associated with the start point of the turn preceding the dead reckoning segment, the length of this track should not exceed 56 km (30 NM).
- b) *Dead reckoning segment*
 - 1) *Orientation.* In all cases the angle between the dead reckoning track and the final approach path shall be 45°.
 - 2) *Length.* The maximum length is 19 km (10 NM). The minimum length is calculated so that an aircraft meeting the most adverse wind conditions is able to complete the turn preceding the dead reckoning segment before initiating the turn onto the final approach track. The minimum length depends on the type of procedure.
- c) *Intermediate approach segment.* The intermediate approach segment begins where the DR track intercepts the intermediate approach track. An intermediate fix is required at this point. The minimum length of the intermediate approach segment depends upon speed and altitude (see Table I-4-3-App A-3). The minimum length of this segment is calculated to allow an aircraft arriving at an angle of 45° — without any indication of the start of the joining turn other than the ILS information — to join and stabilize on the intermediate approach track even in the most adverse conditions.

3.2 Characteristics of the S-type procedures

3.2.1 This type of procedure introduces fewer constraints than the preceding one (see Figure I-4-3-App A-2).

3.2.2 *Start point of the turn onto the DR track.* The start point shall be defined by a fix for which the tolerance shall not exceed ± 3.7 km (± 2.0 NM).

3.2.3 *Minimum length of the DR segment.* The minimum length of the dead reckoning segment to be adopted will be one of the two following values:

- a) start point of the turn defined by VOR intersection: 9 km (5 NM); and

- b) start point of the turn defined by VOR/DME indication: 7 km (4 NM).

These values are adequate provided that the length of the first leg does not exceed 19 km (10 NM); otherwise, they should be increased by 15 per cent of the distance in excess of 19 km (10 NM). **Example:** Start point of the turn defined by VOR intersection; for a 37 km (20 NM) first leg, the length of the DR segment shall not be less than 10.5 km or 6.5 NM.

3.3 Characteristics of the U-type procedures

3.3.1 *Position of the initial approach fix (IAF).* The IAF can be a facility (VOR or VOR/DME) or a fix from which track guidance is available. This fix or facility shall be located outside a sector contained between the final approach path and a straight line L (see Figure I-4-3-App A-1). Line L is determined as follows:

- a) from the FAP draw line D at an angle Ψ to the final approach path.

The length of D varies with the type of facility. Lengths for each type appear in Table I-4-3-App A-3; and

- b) at the end point of line D, draw line L perpendicular to line D.

3.3.1.1 Values for Ψ were determined as follows:

- a) take the angle (45°) between the dead reckoning segment and the ILS axis;
- b) add the maximum angle between the first leg of the initial segment and the dead reckoning segment:
 - 1) $45^\circ + 120^\circ = 165^\circ$ for VOR/DME; and
 - 2) $45^\circ + 105^\circ = 150^\circ$ for VOR/VOR;
- c) take the total from steps 1 and 2, and subtract this from 180. This gives the minimum angle between the first leg of the initial segment and the reverse of ILS axis:
 - 1) $180^\circ - 165^\circ = 15^\circ$ for VOR/DME; and
 - 2) $180^\circ - 150^\circ = 30^\circ$ for VOR/VOR;
- d) subtract the value obtained in c) from 90° in order to have the direction of the perpendicular:
 - 1) $90^\circ - 15^\circ = 75^\circ$ for VOR/DME; and
 - 2) $90^\circ - 30^\circ = 60^\circ$ for VOR/VOR; and
- e) subtract a buffer value of 5° for technical tolerance to give the following values:
 - 1) 70° for VOR/DME; and
 - 2) 55° for VOR/VOR.

3.3.2 Limitation of the angle of turn preceding the dead reckoning segment

- a) Start point of turn defined by an intersection of VOR radials. The angle between the first leg of the initial approach and the dead reckoning segment should not exceed 105°. The angle of intersection of VOR radials should not be less than 45° (See Figure I-4-3-App A-1); and
- b) Start point of turn defined by a VOR/DME fix. In this case the angle of turn should not exceed 120°.

Note.— If a homing facility located on the final approach track in the vicinity of the FAP allows the pilot to control the development of the turn preceding the DR segment, the conditions specified in 3.3.1, “Position of the initial approach fix (IAF)” and 3.3.2, “Limitation of the angle of turn preceding the dead reckoning segment” may be relaxed.

3.3.3 Minimum length of the dead reckoning segment

The minimum length of the dead reckoning segment depends on the following parameters:

- a) the speed of the aircraft;
- b) the angle of turn;
- c) the definition of the point of start of turn;
- d) the altitude; and
- e) the length of the first leg of the initial approach.

Segment lengths appropriate for selected angles of turn are shown in Tables I-4-3-App A-4 through I-4-3-App A-7. Linear interpolation can be applied to determine intermediate values.

Note.— All values shown in the tables are adequate provided the length of the first leg does not exceed 19 km (10 NM). Otherwise these values should be increased by 10 per cent of the distance in excess of 19 km (10 NM). Example: Table I-4-3-App A-7, angle of turn: $\leq 45^\circ$. If the first leg is 22 km (12 NM) long, the minimum lengths of the DR segment become 6.3 and 9.3 km or 3.7 and 5.2 NM.

4. AREAS

4.1 Areas associated with the U-type procedures (see Figures I-4-3-App A-3 and I-4-3-App A-4)

4.1.1 *Initial approach area for the first leg.* This is established according to the criteria in Part III, Chapter 3, 3.3.3, “Area”.

4.1.2 Area for the turn and for the dead reckoning segment.

- a) *Inner edge, primary area.* Join point A to point B.
 - 1) Point A is on the OAS “X” surface abeam the FAP, on the side of the DR segment.
 - 2) Point B is located on the first leg of the initial approach at a distance D before the nominal start point of the turn where:

D = 4.6 km (2.5 NM) when it is defined by the intersection of VOR radials;

D = 1.9 km (1.0 NM) when it is defined by the VOR/DME indication.

- b) *Inner edge, secondary area.* The secondary area associated with the first leg of the initial approach will end on the inside of the turn over this straight line.
- c) *Outer edge, primary area.* This is defined by:
- 1) an arc of a circle centred on the start point of the turn whose radius R is a function of aircraft speed and altitude. Tables I-4-3-App A-8 and I-4-3-App A-9 give the values of the radius R;
 - 2) a straight line which is tangent to the arc of circle and which splays outward at an angle θ to the dead reckoning track according to speed where:

$\theta = 22^\circ$ for IAS 165/335 km/h (90/180 kt);

$\theta = 14^\circ$ for IAS 335/465 km/h (180/250 kt);
 - 3) a straight line from point A to point C, splayed at an angle of 15° from the intermediate approach track where:

Point A is on the OAS X surface abeam the final approach point (FAP); and

Point C is abeam the intermediate approach fix (IF); and
 - 4) a straight line originating from point C parallel to the intermediate approach track.
- d) *Outer edge, secondary area.* The secondary area is located outside of the turn preceding the dead reckoning segment. It is extended up to the outer limit of the protection area defined above.

4.2 Areas associated with the S-type procedures (see Figures I-4-3-App A-5 and I-4-3-App A-6)

- a) *Area for the first leg of the initial approach.* See Part I, Section 4, Chapter 3, 3.3.3, “Area”.
- b) *Area for the turn and the dead reckoning segment.*
- 1) *Outer edge.* This is formed by a straight line joining point A to point S. Point A is located abeam the FAP on the OAS X surface; point S is located abeam the start point of turn on the outer edge of the initial approach area.
 - 2) *Inner edge.*
 - i) First locate point B' on the first leg at a distance from the start point of the turn equal to:

1.9 km (1.0 NM) if the start point is defined by VOR/DME reference;

3.7 km (2.0 NM) if the start point is defined by VOR intersection.
 - ii) Identify point B abeam B' at a distance of 9.3 km (5.0 NM).

- iii) From point B, draw a straight line splaying apart from the DR track at a 22° angle (heading tolerance plus maximum drift angle for the lowest speed category).
- iv) Locate A' on the OAS X surface abeam the FAF.
- v) From A' draw a straight line splaying at 15° from the intermediate approach track to a point C abeam the IF.
- vi) From C draw a straight line parallel to the intermediate approach track.

Table I-4-3-App A-1. Basic values

<i>IAS km/h (kt)</i>	<i>165 (90)</i>	<i>335 (180)</i>	<i>465 (250)</i>		
TAS at 1 500 m (5 000 ft) km/h (kt)	185 (100)	370 (199)	510 (276)		
TAS at 3 000 m (10 000 ft) km/h (kt)		400 (216)	555 (299)		
Turn radius km (NM)	1.05 (0.57)	2.30 (1.24)	2.70 (1.46)	4.42 (2.39)	5.18 (2.80)
Bank angle	17°	25°	25°	25°	25°
Rate of turn (°/s)	3	2.55	2.35	1.84	1.70
Maximum drift for a wind of 56 km/h (30 kt)	17°	9°	8°	6°	6°
Heading tolerance + max drift angle	22°	14°	13°	11°	11°
11 s of flight at km (TAS + W)(NM)	0.89 (0.48)	1.35 (0.78)	1.61 (0.87)	1.89 (1.02)	2.07 (1.12)

Table I-4-3-App A-2. Length of the intermediate approach segment

<i>Altitude</i>	<i>IAS km/h (kt)</i>	
	<i>165/335 (90/180)</i>	<i>335/465 (180/250)</i>
1 500 m (5 000 ft)	11 km (6 NM)	17 km (9 NM)
3 000 m (10 000 ft)	12 km (6.5 NM)	20 km (11 NM)
<i>Note.— For the intermediate altitudes, linear interpolation can be applied.</i>		

Table I-4-3-App A-3. Lengths of line D for types of facility and airspeed

Facility	Ψ	D for IAS < 335 km/h (180 kt)	D for IAS < 465 km/h (250 kt)
VOR/VOR	55°	16 km (8.5 NM)	23 km (12.5 NM)
VOR/DME	70°	12 km (6.5 NM)	18 km (9.5 NM)

**Table I-4-3-App A-4. Minimum length of the DR segment
Start point defined by VOR intersection — Altitude: 1 500 m (5 000 ft)**

IAS km/h (kt)	Angle of turn			
	$\leq 45^\circ$	60°	90°	105°
165/335 km/h (90/180 kt)	10 km (5.5 NM)	11 km (6 NM)	12 km (6.5 NM)	12 km (6.5 NM)
335/465 km/h (180/250 kt)	13 km (7 NM)	14 km (7.5 NM)	15 km (8 NM)	16 km (8.5 NM)

**Table I-4-3-App A-5. Minimum length of the DR segment
Start point defined by VOR intersection — Altitude: 3 000 m (10 000 ft)**

IAS km/h (kt)	Angle of turn			
	$\leq 45^\circ$	60°	90°	105°
165/335 km/h (90/180 kt)	11 km (6 NM)	12 km (6.5 NM)	13 km (7 NM)	14 km (7.5 NM)
335/465 km/h (180/250 kt)	15 km (8 NM)	16 km (8.5 NM)	18 km (9.5 NM)	19 km (10 NM)

**Table I-4-3-App A-6. Minimum length of the DR segment
Start point defined by VOR/DME fix — Altitude: 1 500 m (5 000 ft)**

IAS km/h (kt)	Angle of turn			
	$\leq 45^\circ$	60°	90°	105°
165/335 km/h (90/180 kt)	6 km (3.5 NM)	8 km (4.5 NM)	9 km (5 NM)	10 km (5.5 NM)
335/465 km/h (180/250 kt)	9 km (5 NM)	11 km (6 NM)	13 km (7 NM)	15 km (8 NM)

**Table I-4-3-App A-7. Minimum length of the DR segment
Start point defined by VOR/DME fix — Altitude: 3 000 m (10 000 ft)**

IAS km/h (kt)	Angle of turn			
	≤45°	60°	90°	105°
165/335 km/h (90/180 kt)	6 km (3.5 NM)	9 km (5 NM)	11 km (6 NM)	12 km (6.5 NM)
335/465 km/h (180/250 kt)	9 km (5 NM)	11 km (6 NM)	15 km (8 NM)	18 km (9.5 NM)

Note.— All values shown in the tables are adequate provided the length of the first leg does not exceed 19 km (10 NM). Otherwise these values should be increased by 10 per cent of the distance in excess of 19 km (10 NM). Example: Table I-4-3-App A-7, angle of turn: ≤45°. If the first leg is 22 km (12 NM) long the minimum lengths of the DR segment become 6.3 and 9.3 km or 3.7 and 5.2 NM.

**Table I-4-3-App A-8. R values for a start point of turn
defined by VOR intersection**

IAS km/h (kt)	Altitude	
	1 500 m (5 000 ft)	3 000 m (10 000 ft)
165/335 km/h (90/180 kt)	10.2 km (5.5 NM)	11.1 km (6 NM)
335/465 km/h (180/250 kt)	12.0 km (6.5 NM)	13.9 km (7.5 NM)

**Table I-4-3-App A-9. R values for a start point of turn
defined by VOR/DME**

IAS km/h (kt)	Altitude	
	1 500 m (5 000 ft)	3 000 m (10 000 ft)
165/335 km/h (90/180 kt)	9.3 km (5.0 NM)	9.3 km (5.0 NM)
335/465 km/h (180/250 kt)	10.2 km (5.5 NM)	12.0 km (6.5 NM)

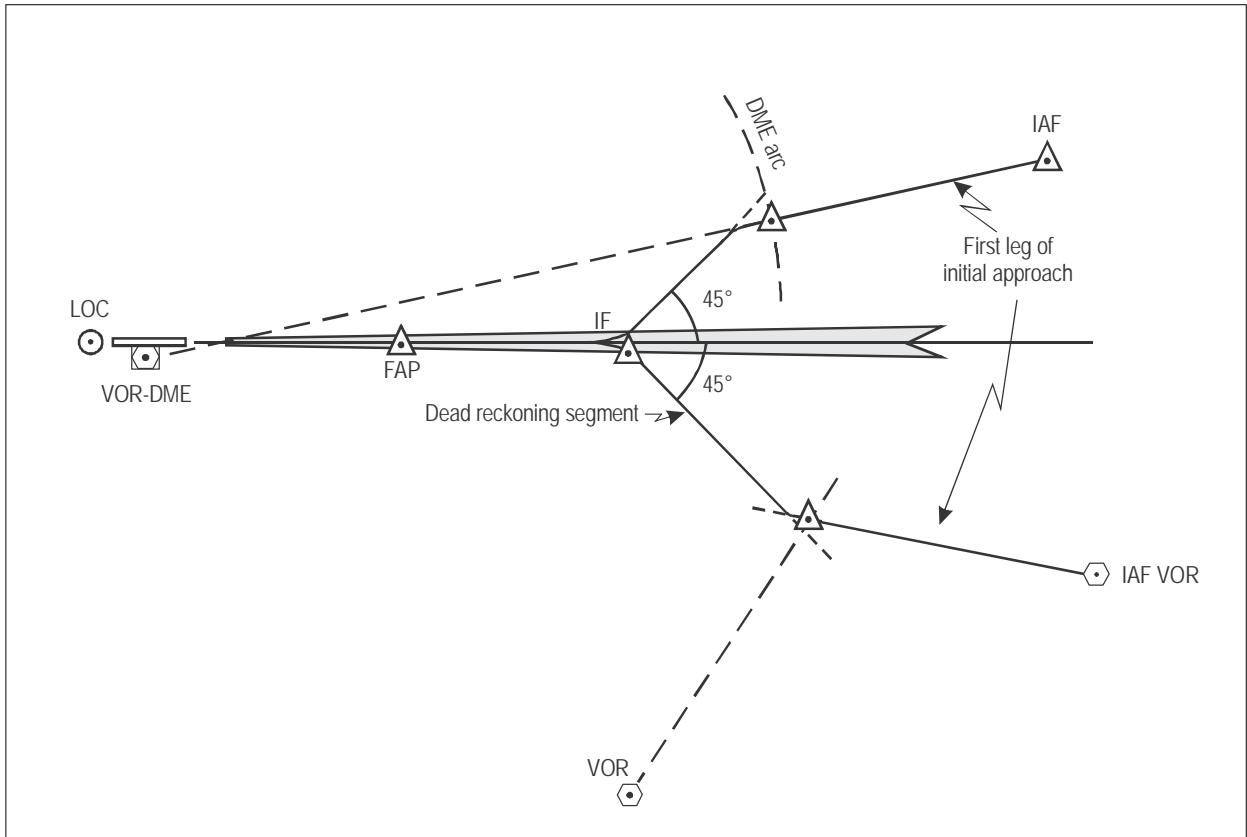

Figure I-4-3-App A-2. S-type procedure

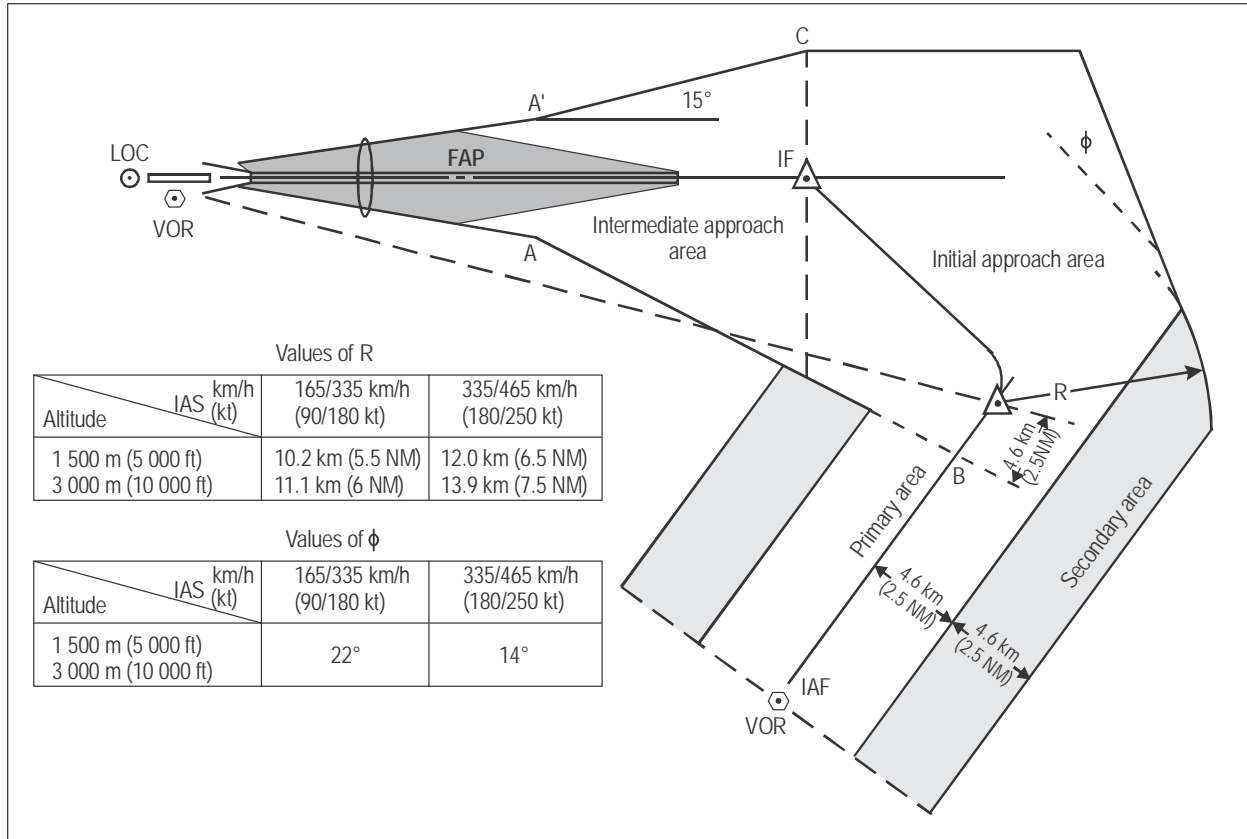

Figure I-4-3-App A-3. U-type VOR/VOR procedure construction of protection areas

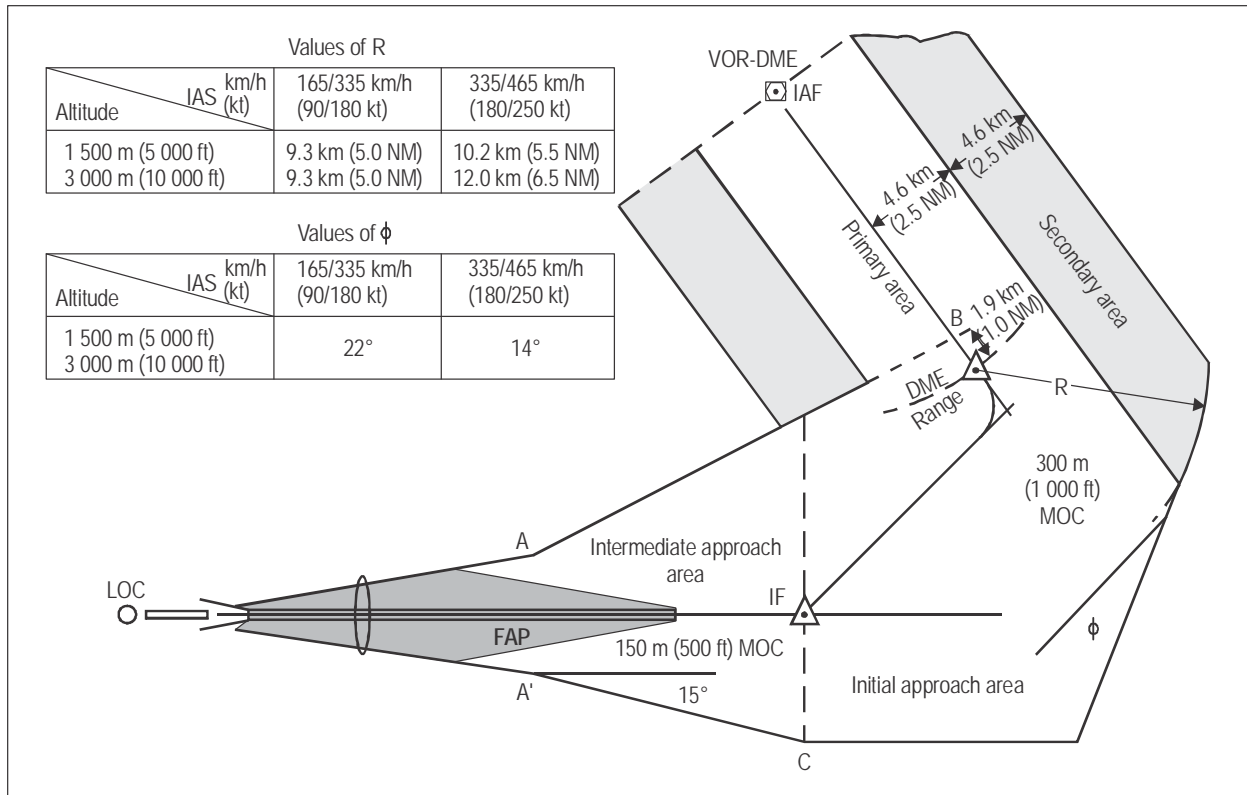

Figure I-4-3-App A-4. U-type VOR/DME procedure construction of protection areas

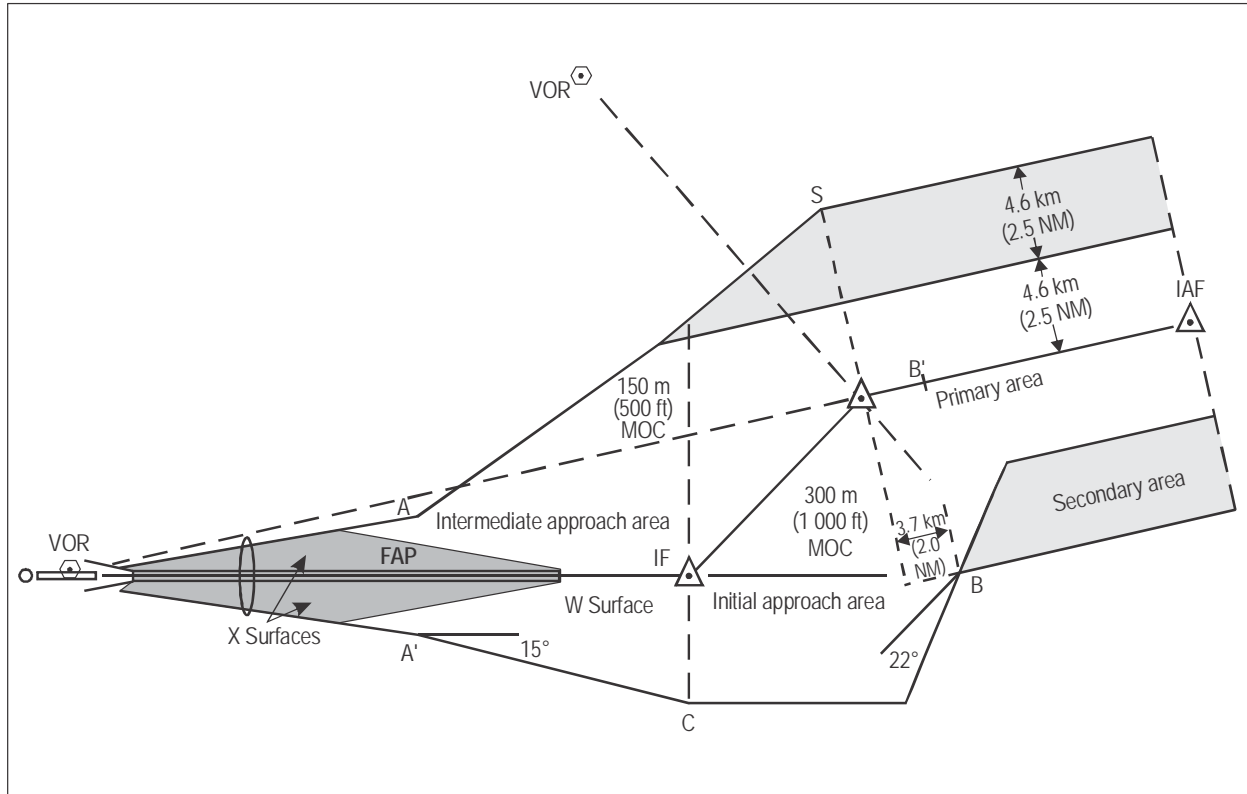

Figure I-4-3-App A-5. S-type VOR/VOR procedure construction of protection areas

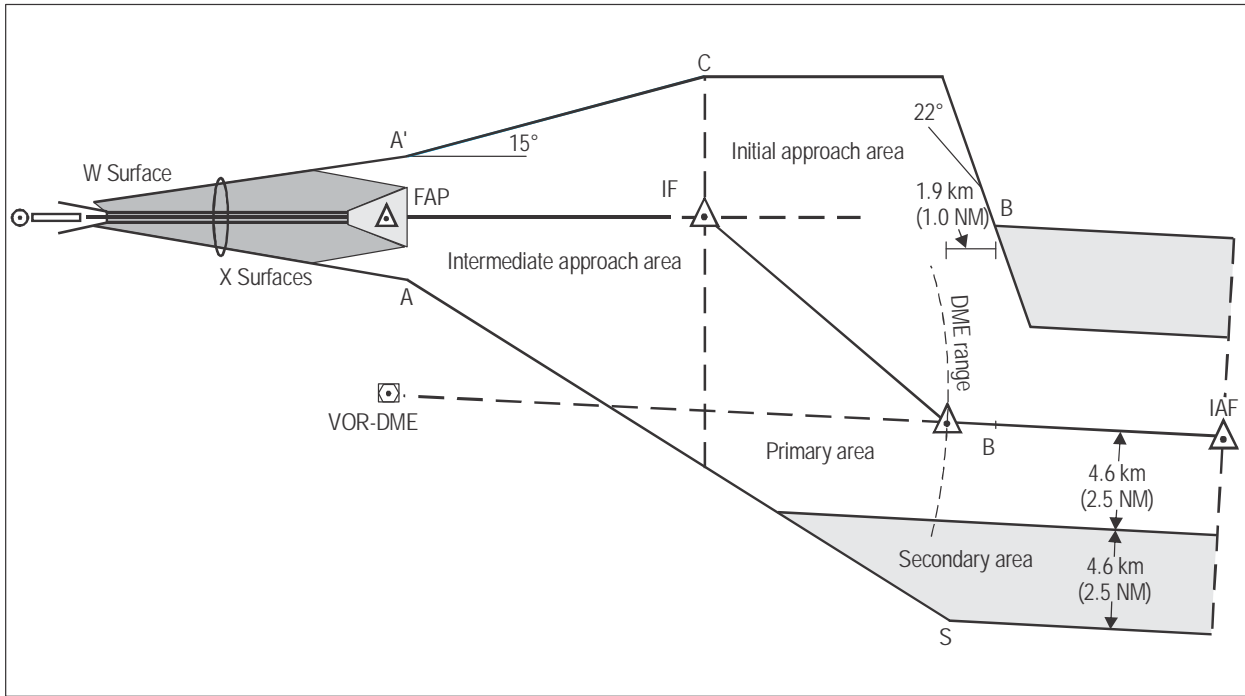

Figure I-4-3-App A-6. S-type VOR/DME procedure construction of protection areas

Appendix B to Chapter 3

REDUCTION OF THE WIDTH OF A STRAIGHT INITIAL APPROACH AREA AFTER THE IAF AND INTERFACE BETWEEN STRAIGHT INITIAL APPROACH AREA AND REVERSAL PROCEDURE AREAS

(see Chapter 3, 3.3.2)

1. REDUCTION OF THE WIDTH OF A STRAIGHT INITIAL APPROACH AREA AFTER THE IAF

1.1 General

Where the initial approach includes a straight segment ending at an intermediate approach fix (IF) defined by a VOR, NDB or RNAV waypoint, its width at the IF is reduced from the appropriate en-route width to:

- a) ± 3.7 km (2.0 NM) at a VOR;
- b) ± 4.6 km (2.5 NM) at an NDB; or
- c) the calculated area width for an RNAV waypoint.

1.2 Justification

The guidance provided is considered sufficient. The cone effect area radius is:

- a) 3.7 km (2.0 NM) for a VOR at 3 000 m (10 000 ft); and
- b) 4.6 km (2.5 NM) for an NDB at 5 500 m (18 000 ft).

The area width at the IF for the RNAV case can be calculated. It is assumed that the flight technical tolerance is diminishing after the aircraft has passed the initial approach fix (IAF).

1.3 VOR cases

1.3.1 *The IAF is at a distance of more than 40.5 km (21.9 NM) from the VOR.* From a distance of 40.5 km (21.9 NM) from the VOR and up to the VOR, the width of the area on each side of the nominal track is reduced linearly from 9.3 km (5.0 NM) to 3.7 km (2.0 NM), the outer boundary of the area converging at an angle of 7.8° with the nominal track (Figure I-4-3-App B-1).

1.3.2 *The IAF is at a distance of less than 40.5 km (21.9 NM) from the VOR.* The width of the area on each side of the nominal track is reduced linearly from 9.3 km (5.0 NM) at the IAF to 3.7 km (2.0 NM) at the VOR (Figure I-4-3-App B-2).

1.4 NDB cases

1.4.1 *The IAF is at a distance of more than 25.5 km (13.8 NM) from the NDB.* From a distance of 25.5 km (13.8 NM) from the NDB and up to the NDB the width of the area on each side of the nominal track is reduced linearly from 9.3 km (5.0 NM) to 4.6 km (2.5 NM), the outer boundary of the area converging at an angle of 10.3° with the nominal track (Figure I-4-3-App B-3).

1.4.2 *The IAF is at a distance of less than 25.5 km (13.8 NM) from the NDB.* The width of the area on each side of the nominal track is reduced linearly from 9.3 km (5.0 NM) at the IAF to 4.6 km (2.5 NM) at the NDB (Figure I-4-3-App B-4).

2. PROTECTION OF A TURN AT THE IF

Where a turn at the IF greater than 10° is specified, the intermediate approach area should be widened on the outer side of the turn, using the method described in Chapter 6, 6.4.6.3.3 based on a bank angle of 25° (or on that angle giving a turn rate of 3°/s, whichever is the lesser) and on the maximum initial speed for the aircraft category. Figure I-4-3-App B-5 shows an example of this additional area to protect the turn.

3. INTERFACE BETWEEN STRAIGHT INITIAL APPROACH AREA AND REVERSAL PROCEDURE AREAS

The secondary area width of a reversal procedure is:

- a) 1.9 km (1.0 NM) if it is based on a VOR; and
- b) 2.3 km (1.25 NM) if it is based on an NDB.

The corresponding areas are related as shown in Figure I-4-3-App B-6.

Note.— In Figure I-4-3-App B-6 the VOR facility marks the turning point in the initial approach segment. The intermediate approach segment starts only after completion of the reversal procedure turn.

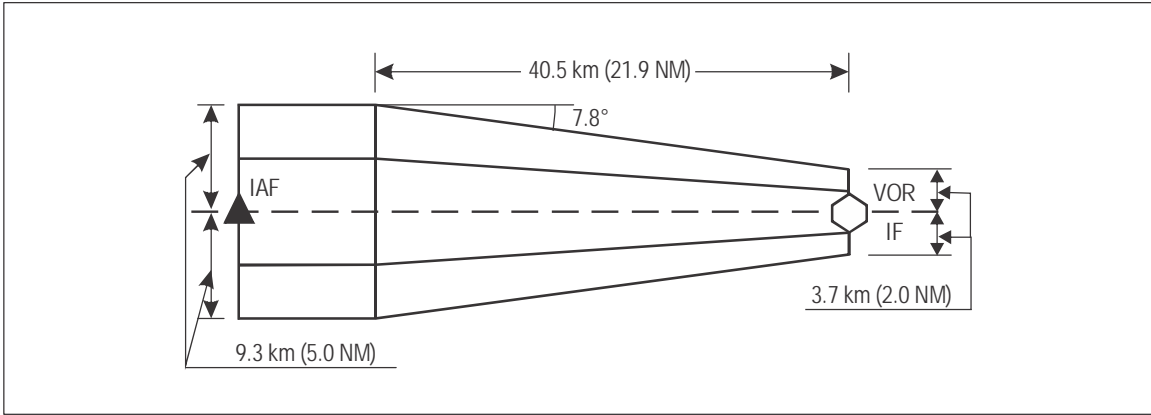

Figure I-4-3-App B-1. Case where the IAF is more than 40.5 km (21.9 NM) from the VOR

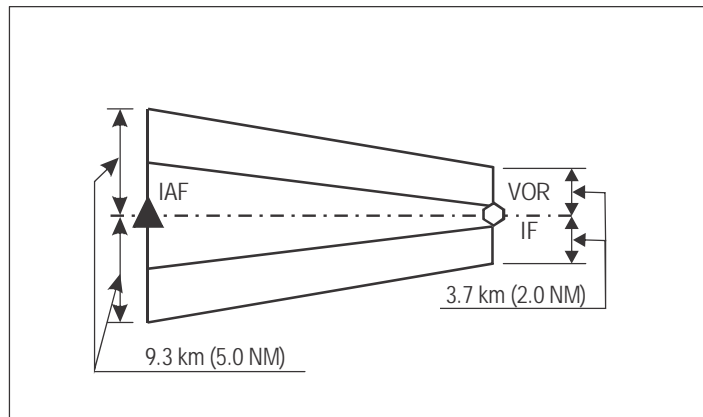

Figure I-4-3-App B-2. Case where the IAF is less than or equal to 40.5 km (21.9 NM) from the VOR

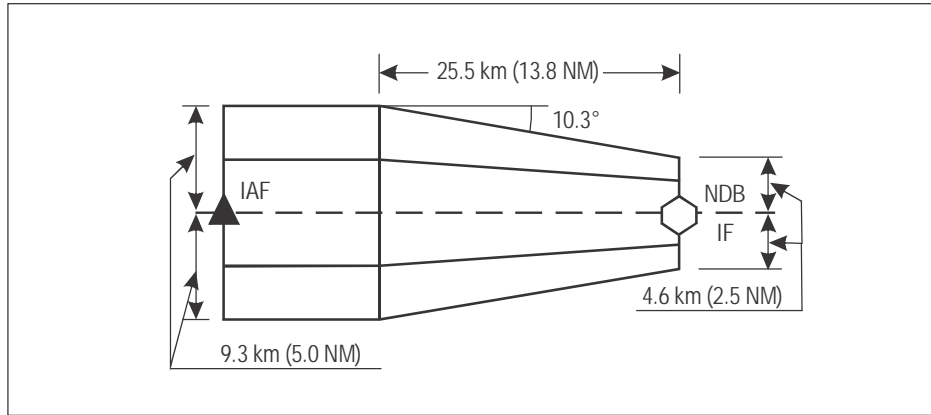

Figure I-4-3-App B-3. Case where the IAF is more than 25.5 km (13.8 NM) from the NDB

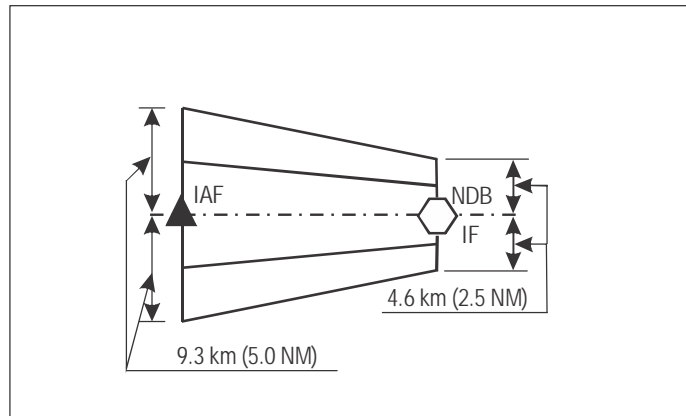

Figure I-4-3-App B-4. Case where the IAF is less than or equal to 25.5 km (13.8 NM) from the NDB

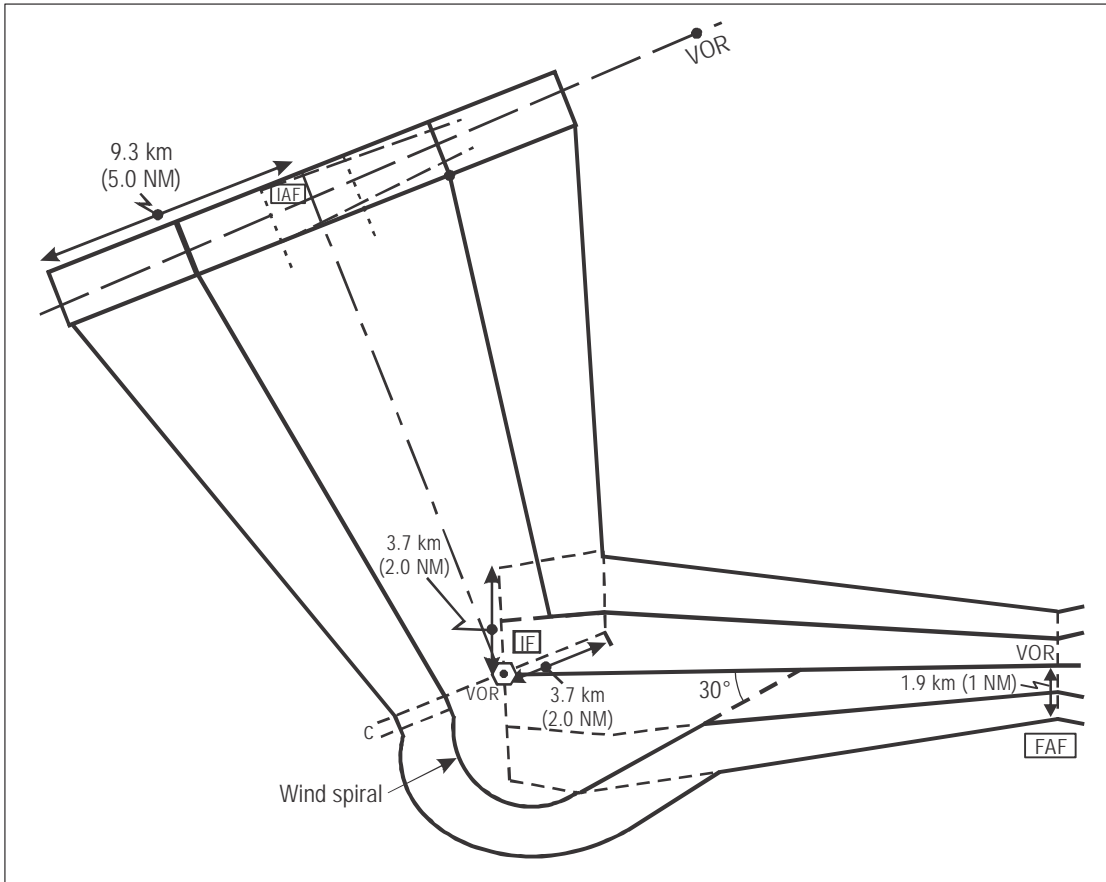

Figure I-4-3-App B-5. Reduction in area widths — initial segment jointed to intermediate segment by a turn

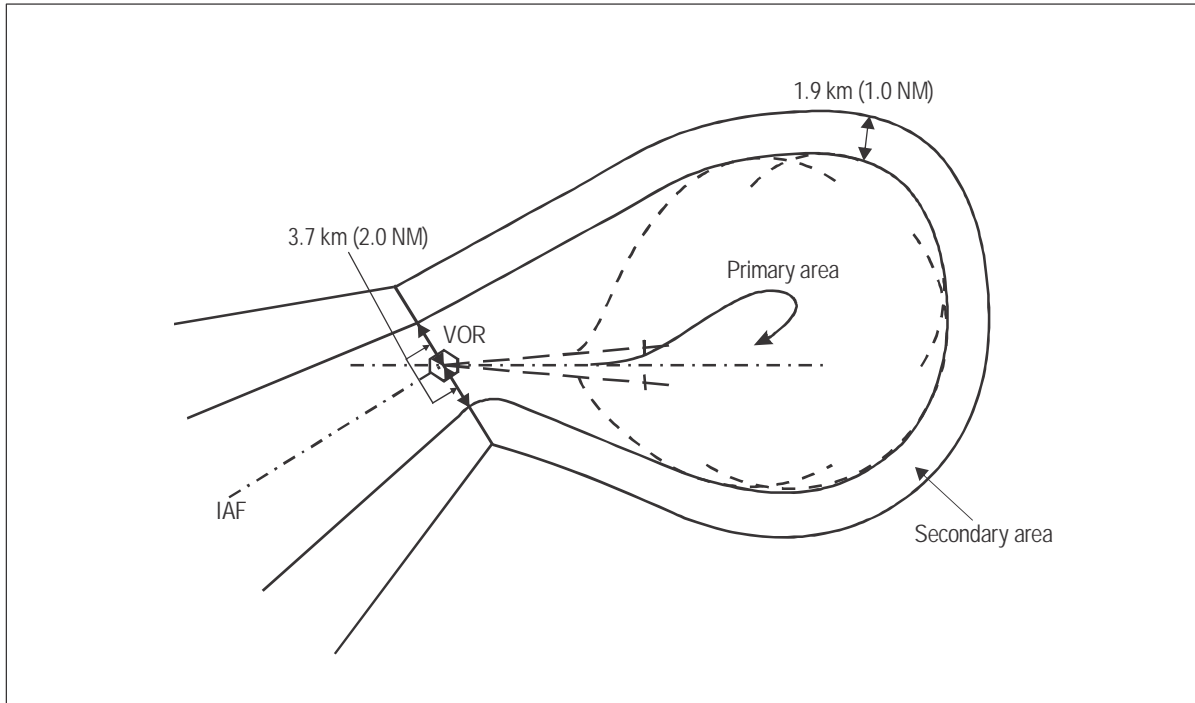

Figure I-4-3-App B-6. Interface between primary and secondary areas of initial approach and reversal procedures (example with a VOR)

Appendix C to Chapter 3

CONSTRUCTION OF OBSTACLE CLEARANCE AREAS FOR REVERSAL AND HOLDING PROCEDURES

1. INTRODUCTION

The construction of obstacle clearance areas for reversal procedures (Part III, Section 3, Chapter 7) is based on the direct application of the tolerance criteria specified in Part I, Section 2, Chapter 2. These may be applied either on an additive tolerance basis, or using statistical methods.

2. STATISTICAL AREA CONSTRUCTION

If statistical methods are used to combine the variables and then to extrapolate distributions to develop areas, the probability level associated with that extrapolation should meet an acceptable level of safety.

3. ADDITIVE TOLERANCE AREA CONSTRUCTION

A variety of methods may be used; whichever method is used, the criteria and parameters given in 3.5 of Part III, Section 3, Chapter 7 apply. The method described in this attachment is the template tracing technique (TTT).

3.1 Protection area of a base turn

3.1.1 *General*

The primary area of a base turn can be drawn by applying the construction method of the template specified in 3.1.2 of this appendix for the appropriate timing, speed and altitude. This template caters for all factors which can cause an aircraft to deviate from the nominal track, tolerances of the navigational facility, flight technical tolerances and wind effect, so that it represents the primary area of the base turn.

3.1.2 *Construction of the base turn template* (Reference Table I-4-3-App C-1 and Diagram I-4-3-App C-1)

3.1.2.1 Draw a line representing the axis of the procedure and locate point “a” on the fix — draw the nominal outbound leg and inbound turn:

— *angle between outbound leg and procedure axis:* θ (Table I-4-3-App C-1, line 10)

— *outbound leg length*: L (Table I-4-3-App C-1, line 13)

— *radius of turn*: r (Table I-4-3-App C-1, line 5).

3.1.2.2 *Protection of the outbound leg* From “a” draw two lines at an angle of 5.2° for a VOR and 6.9° for an NDB on each side of the nominal outbound leg. Locate points b1, b2, b3 and b4 on these lines (Table I-4-3-App C-1, lines 14 and 15). These points determine the area containing the beginning of the inbound turn.

3.1.2.3 *Protection of the inbound turn*

3.1.2.3.1 With a centre on c2 at a distance r from b2 on the perpendicular to the nominal outbound leg and a radius r, draw an arc beginning at b2. Locate points d and e after 50 and 100 degrees of turn after b2. Similarly, draw an arc beginning at b4 and locate point f after 100 degrees of turn after b4 and draw an arc beginning at b3 and locate points i and j after 190 and 235 degrees of turn after b3.

3.1.2.3.2 *Influence of the wind*

- a) The wind effect is calculated for each point of the turn by multiplying E, the wind effect during one degree, by the number of degrees of turn;
- b) draw arcs with centres d, e, f, i and j and radii W_d , W_e , W_f , W_i and W_j (Table I-4-3-App C-1, lines 16 to 19). The arc centred on f is called arc f;
- c) draw a line tangent to the arc centred on e (or f if more conservative) making an angle d (Table I-4-3-App C-1, line 20) with the perpendicular to the inbound track and locate point k at its intersection with the inbound track. With a centre on C5 at a distance r from k on the nominal inbound track, and a radius r, draw an arc beginning at k. Locate points g and h after 50 and 100 degrees of turn after k; and
- d) draw arcs with centres g and h and radii W_g and W_h (Table I-4-3-App C-1, lines 16 and 17).

3.1.2.4 *Drawing of the protection area of the base turn.* The outline of the protection area is composed of:

- a) the spiral envelope of the arcs centred on “d” and “e”;
- b) the spiral envelope of the arcs centred on “g” and “h”;
- c) the spiral envelope of the arcs centred on “i” and “j”;
- d) the tangent to the spiral a) passing through “a”;
- e) the tangent to the spirals a) and b) or the tangent to the spiral a) and arc f, a portion of arc f, and the tangent to arc f and b);
- f) the tangent to the spirals b) and c); and
- g) the tangent to the spiral c) passing through “a”.

Note.— If point a lies within spiral c), the outbound time should be increased.

3.1.2.5 Protection of the entry

3.1.2.5.1 Entry along a straight segment (see 3.2.5)

3.1.2.5.2 Entry along a holding or racetrack procedure (see Diagram I-4-3-App C-2)

3.1.2.5.2.1 Let ϕ be the angle between the inbound track of the holding or racetrack procedure and the outbound track of the base turn. From a, draw line E making an angle ϕ from the nominal outbound track and draw the position fix tolerance area with reference to that line, as described in 3.3.2.2.4.4 for a VOR and 3.3.2.2.4.5 for an NDB.

3.1.2.5.2.2 Draw line E' parallel to E passing through V_3 (respectively N_3) and locate point l (Table I-4-3-App C-1, line 21). Draw an arc of 100° with a radius r tangent to line E' at l and locate points m and n after 50° and 100° of turn from l . Draw arcs with centres l , m and n and radii W_l , W_m and W_n (Table I-4-3-App C-1, lines 22, 23 and 24).

3.1.2.5.2.3 Draw the spiral envelope of the arcs centred on l , m and n and its tangent from V_3 (respectively N_3).

3.1.2.5.2.4 Draw the tangent between the entry spiral above and the protection area of the base turn.

3.1.3 Secondary area

Draw the secondary area limit at a distance of 4.6 km (2.5 NM) from the boundary of the primary area.

Note.— See Appendix B to Chapter 3 for a possible reduction of the width of the secondary area.

3.2 Protection area of a procedure turn

3.2.1 General

The construction of the protection area of a procedure turn is made in two steps.

- The first is to construct a procedure turn template (see 3.2.2 or 3.2.3) for the appropriate speed and altitude. This template caters for all factors which can cause an aircraft to deviate from the nominal track, except those which define the tolerance area of the beginning of the outbound track.
- The second step is to draw the protection area of the procedure turn by moving the template point “a” around the tolerance area of the beginning of the outbound turn as described in 3.2.4 of this appendix.

3.2.2 Construction of the 45° — 180° procedure turn template (Reference Table I-4-3-App C-2 and Diagram I-4-3-App C-3)

3.2.2.1 *Nominal track.* Draw a line representing the axis of the procedure and locate points “a” and “b” on it (Table I-4-3-App C-2, line 10). Beginning at “b” and ending at “c”, draw the nominal outbound turn of 45° . Draw between “c” and “d” the nominal outbound leg and beginning at “d” the nominal inbound turn of 180° .

— *radius of the turns:* r (Table I-4-3 App C-2, line 5)

— *outbound leg length:* cd (Table I-4-3 App C-2, line 11).

3.2.2.2 Influence of the flight technical tolerances

- a) From “c” draw two lines at 5 degrees on each side of the nominal outbound leg.
- b) Locate points “d1”, “d2”, “d3” and “d4” on these lines (Table I-4-3 App C-2, lines 12 and 13).
- c) With a centre on “e2” at a distance r from “d2” on the perpendicular line to the nominal outbound leg (line passing through d2 and d4), and a radius r, draw the inbound turn beginning at “d2”. Locate points “f” and “g” after 50 and 100 degrees of turn from “d2”. With centres on “e3” and “e4”, draw the corresponding arcs beginning at “d3” and “d4”. Locate points “h”, “i” and “j” after 100, 150 and 200 degrees from “d4” and points “k” and “l” after 200 and 250 degrees of turn from “d3”.

3.2.2.3 Influence of the wind

- a) The wind effect is calculated for each point by multiplying the wind speed w by the flying time from point “a”.
- b) Draw arcs with centres “c”, “d2”, “f”, “g”, “h”, “i”, “j”, “k” and “l” and radii W_c , W_{d2} , W_f , W_g , W_h , W_i , W_j , W_k and W_l (Table I-4-3 App C-2, lines 14 to 21).

3.2.2.4 Drawing of the outline of the template. The outline of the template is composed of:

- a) the tangent passing through “a” to the arc centred on “c”;
- b) the common tangent to the arcs centred on “c” and “d2”;
- c) the spiral envelope of the arcs centred on “d2”, “f” and “g”;
- d) the spiral envelope of the arcs centred on “h”, “i” and “j”;
- e) the spiral envelope of the arcs centred on “k” and “l”;
- f) the common tangent to the spirals c) and d);
- g) the common tangent to the spirals d) and e); and
- h) the tangent passing through “a” to the spiral e).

3.2.3 Construction of the 80° — 260° procedure turn template (Reference Table I-4-3-App C-3 and Diagram I-4-3-App C-4)

3.2.3.1 *Nominal track.* Draw a line representing the axis of the procedure and locate points “a” and “b” on it (Table I-4-3-App C-3, line 10). With a centre “c” at a distance r (Table I-4-3-App C-3, line 5) from “b” on the perpendicular line to the procedure axis passing through “b”, draw the nominal outbound turn of 80° and locate point “d” at the end of this turn. From “d” draw the tangent to the nominal outbound turn and locate point “e” on this tangent (Table I-4-3-App C-3, line 11). With a centre on “f” and a radius r, draw the nominal inbound turn of 260° beginning at “e”.

3.2.3.2 *Influence of the flight technical tolerances*

- a) On the nominal outbound turn, locate points “d1” and “d2” after 75 and 85 degrees of turn from “b”.
- b) From “d1” and “d2”, draw the tangents to the outbound turn and locate points “e1” and “e2” on these tangents (Table III-C-3, line 11).
- c) With a centre on “f2” at a distance r from “e2” on the perpendicular line to d2e2, draw the inbound turn at “e2”. Locate points “g”, “h”, “i” and “j” after 45, 90, 135 and 180 degrees of turn from “e2”.
- d) With a centre on “f1”, draw the inbound turn beginning at “e1” and locate points “k”, “l” and “m” after 180, 225 and 270 degrees of turn from “e1”.

3.2.3.3 *Influence of the wind*

- a) The wind effect is calculated for each point by multiplying the wind speed w by the flying time from the point “a”, beginning of the turn.
- b) Draw arcs with centres “e2”, “g”, “h”, “i”, “j”, “k”, “l” and “m” and radii W_{e2} , W_g , W_h , W_i , W_j , W_k and W_l (Table I-4-3-App C-3, lines 12 to 19).

3.2.3.4 *Drawing of the outline of the template.* The outline of the template is composed of:

- a) the spiral envelope of the arcs centred on “e2”, “g”, “h”, “i” and “j”;
- b) the spiral envelope of the arcs centred on “k”, “l” and “m”;
- c) the common tangent to the spirals a) and b);
- d) the tangent passing through “a” to the spiral a); and
- e) the tangent passing through “a” to the spiral b).

3.2.4 *Drawing of the protection area of the procedure turn*
(Reference Diagram I-4-3-App C-5)3.2.4.1 *Tolerance area of the beginning of the outbound turn*

3.2.4.1.1 From the facility, point 0, draw the radial of the procedure and its two protection lines. These lines make an angle of 6.9° if the facility is NDB, 5.2° if the facility is a VOR, or 2.4° if the facility is a localizer, on each side of the radial.

3.2.4.1.2 Locate point A on the nominal beginning of the outbound turn.

3.2.4.1.3 According to the type of facility at 0 and eventually at A or 0, draw the tolerance area of point A A1 A2 A3 A4 as described on the Figures I-4-3-App C-1 to I-4-3-App C-5.

Note.— Units in following formulas:

	SI units	Non-SI units
<i>t</i>	<i>s</i>	<i>s</i>
<i>v and w'</i>	<i>km/s</i>	<i>NM/s</i>
<i>Distances</i>	<i>Km</i>	<i>NM</i>

The values of *v*, *w'* and *h* are given by Table I-4-3-App C-1 (lines 3, 8 and 6 respectively). *D* is the specified DME distance expressed in km (NM) and *d1* is the tolerance of this DME indication:

$$d1 = 0.46 \text{ km (0.25 NM)} + 0.0125 D$$

3.2.4.2 Primary area

- Place the template point “a” on “A1”, with the template procedure axis parallel to the inbound track, and draw the curve “1” (part of the outline of the template).
- In the same manner, place the template point “a” successively on “A2”, “A3” and “A4” to draw curves “2”, “3” and “4”.
- Draw the common tangents to curves “1” and “2”, “2” and “4”, “3” and “4” and the tangent from “0” to curve “1” and from “0” to curve “3”.

3.2.4.3 *Secondary area.* Draw the secondary area limit at a distance of 4.6 km (2.5 NM) from the boundary of the primary area.

3.2.5 Interface between initial segment area and base and procedure turn areas

3.2.5.1 *General.* The primary area of the initial segment, the boundaries of which are 4.6 km (2.5 NM) apart from the nominal path, shall be blended with the primary area of the turn procedure, which is described above in 3.1.2 (base turn) and 3.2.4 (procedure turn). The secondary areas of the two phases of the procedure shall be blended so that a constant width of 4.6 km (2.5 NM) is respected.

3.2.5.2 *Construction of the secondary area outerboundary (see Figures I-4-3-App C-6 and I-4-3-App C-7).* On one side of the initial segment path the outer boundaries of the two secondary areas will intersect. On the other side of the initial segment path, the outer boundary of the secondary area consists of an arc of circle, 9.2 km (5 NM) from the facility, and the tangent to that circle and the outer boundary of the secondary area of the turn.

3.2.5.3 *Construction of the primary area boundary.* The boundary of the primary area is drawn in 4.6 km (2.5 NM) from the outer boundary of the secondary area.

3.3 Protection area of racetrack and holding procedures

3.3.1 General

Note.— The methods described in this paragraph are related to right turn procedures. For left turn procedures, the corresponding areas are symmetrical with respect to the inbound track.

3.3.1.1 The protection area of a racetrack procedure consists of a primary area and a secondary area; the protection area of a holding procedure consists of an area and a buffer area. Since the construction of the primary area of a racetrack and of the area of a holding is the same, they are referred to by the same term hereafter — *the basic area of the procedure*.

3.3.1.2 The construction of the basic area of the procedure is made in two steps.

3.3.1.2.1 The first step is to construct a template for the appropriate time, speed and altitude. This template caters for all factors which can cause an aircraft to deviate from the nominal pattern except those related to the fix tolerance area. It is applicable to all types of procedures including VOR or NDB overhead, intersection of VOR radials, VOR/DME and their entries.

3.3.1.2.2 The second step is to draw the basic area of the procedure by moving the template-origin around the fix tolerance area for procedures overhead a facility or at the intersection of VOR radials, or by using it as described in 3.3.4 for VOR/DME procedures, and by adding areas to protect entries as required.

3.3.1.3 Finally, a secondary area of 4.6 km (2.5 NM) is added around the basic area for a racetrack, and a buffer area of 9.3 km (5.0 NM) is added around the basic area for a holding.

3.3.2 *First step: construction of the template* (Reference Table I-4-3-App C-4 and Diagram I-4-3-App C-6)

3.3.2.1 The parameters used in the construction of the template are contained in Chapter 3, 3.6.2 for the racetrack and in Part II, Section 4, Chapter 1, 1.3, “Construction of holding areas”, for the holding procedures.

3.3.2.2 After completion of the calculations indicated in Table I-4-3-App C-4, the template is constructed as follows.

3.3.2.2.1 Draw a line representing the axis of the procedure and the nominal pattern. Locate point “a” at the procedure fix. (The radius of turn r is given at line 5 and the outbound length L is given at line 11 of Table I-4-3-App C-4.)

3.3.2.2.2 *Influence of the navigation tolerances*

3.3.2.2.2.1 Locate points “b” and “c” on the procedure axis (Table I-4-3-App C-4, lines 12 and 13); “b” and “c” represent the earliest (5 s after “a”) and the latest (11 s after “a”) still air positions of the beginning of the outbound turn.

3.3.2.2.2.2 Draw an arc of 180° with a radius r tangent to the procedure axis at “c”, which represents the latest still air outbound turn. Locate points “d”, “e”, “f” and “g” after 45, 90, 135 and 180° of turn from “c”.

3.3.2.2.2.3 Draw an arc of 270° with a radius r tangent to the procedure axis at “b”, which represents the earliest still air outbound turn. Locate points “h”, “o” and “p” after 180, 225 and 270° of turn from “b”.

3.3.2.2.2.4 From “g” draw two lines at 5° on each side of the nominal outbound leg. Locate points “i1”, “i2”, “i3” and “i4” on these lines (Table I-4-3-App C-4, lines 14 and 15). “i1” and “i3” are plotted $(60T - 5)$ seconds after “g”; “i2” and “i4” should be $(60T + 15)$ seconds after “h”, but for the sake of simplification they are plotted $(60T + 21)$ seconds after “g”. i1 i2 i3 i4 determine the area containing the still air position of the beginning of the inbound turn.

3.3.2.2.2.5 With a centre at a distance r below “i2” on the perpendicular line to the nominal outbound leg, and a radius r draw an arc of 180° beginning at “i2” and ending at “n2”. Locate points “j” and “k” after 45° and 90° of turn from “i2”. Draw the corresponding arc beginning at “i4” and ending at “n4”. Locate points “l” and “m” after 90° and 135° of turn from “i4”.

3.3.2.2.2.6 The end of the inbound turn in still air conditions is contained in the area $n1\ n2\ n3\ n4$ reduced from $il\ i2\ i3\ i4$ by a translation of one diameter of nominal turn.

3.3.2.2.3 *Influence of the wind*

3.3.2.2.3.1 The wind effect is calculated for each point by multiplying the wind speed (Table I-4-3-App C-4, line 7) with the flying time from “a” to the point.

3.3.2.2.3.2 *Influence of the wind during the outbound turn:* Draw arcs with centres “b”, “c”, “d”, “e” and “f” and radii W_b , W_c , W_d , W_e and W_f (Table I-4-3-App C-4, lines 16 to 20).

3.3.2.2.3.3 The area containing the end of the outbound turn is determined by two arcs with centres “g” and “h” and radii W_g and W_h (Table I-4-3-App C-4, lines 21 and 22) and their common tangents.

3.3.2.2.3.4 The area containing the beginning of the inbound turn is determined by the four arcs with the centres “i1”, “i2”, “i3” and “i4” and radii W_{i1} , W_{i2} , W_{i3} and W_{i4} (Table I-4-3-App C-4, lines 25 and 26) and their four common tangents.

3.3.2.2.3.5 *Influence of the wind during the inbound turn:* Draw arcs with centres “j”, “k”, “l”, “m”, “n4” and “n3” and radii W_j , W_k , W_l , W_m , W_{n4} and W_{n3} (Table I-4-3-App C-4, lines 27 to 31).

3.3.2.2.3.6 Draw arcs with centres “o” and “p” and radii W_o and W_p (Table I-4-3-App C-4, lines 23 and 24).

3.3.2.2.4 *Drawing of the template*

3.3.2.2.4.1 The outline of the template is composed of:

- a) the spiral envelope of the arcs centred on “c”, “d”, “e”, “f” and “g”;
- b) the arc centred on “il” and the common tangent to this arc and the spiral a);
- c) the common tangent to the arcs centred on “i1” and “i2”;
- d) the spiral envelope of the arcs centred on “i2”, “j” and “k”, the spiral envelope of the arc centred on “l”, “m” and “n4” and their common tangent;
- e) the arcs centred on “n3” and “n4” and their common tangent; and
- f) the tangent to the arc centred on “n3” and to the spiral a), except when the arc fails to intersect the spiral (an occurrence in certain combinations of low TAS and high wind speed). In this case a geometric solution is used and the arc terminates at its intersection with the AC axis. From this intersection, a second arc centred on point a is drawn to intersect the spiral a). A common tangent is then drawn between the arc and spiral a) to enclose the area. See Diagram 1-4-3-App C-6 a).

3.3.2.2.4.2 The protection of the outbound leg in the direction of the D axis is represented by the common tangents to the arcs centred on “g”, “i3” and “i4”, called line “3” (see Diagrams I-4-3-App C-6, I-4-3-App C-7 and I-4-3-App C-8).

3.3.2.2.4.3 The protection of a turn of more than 180° is represented by:

- a) the spiral envelope of the arcs centred on “c”, “d”, “e”, “f” and the tangent to this spiral passing through “a”; and
- b) the spiral envelope of the arcs centred on “h”, “o” and “p” and the tangent to this spiral and to the area drawn in 3.3.2.2.3.3.

3.3.2.2.4.4 *VOR position fix tolerance area*: See Section 2, Chapter 2, 2.5.1.

3.3.2.2.4.5 *NDB position fix tolerance area*: See Section 2, Chapter 2, 2.5.2.

3.3.2.2.4.6 *Point “R”*. This point is used to determine the lowest position of the limiting radial, so that this radial does not cross the area containing the end of the outbound turn. It is located as follows:

- a) draw the tangent to the area containing the end of the outbound turn passing through the intersection point of the outline of the template with the C axis; and
- b) locate point “R” at the intersection of this tangent with the curve drawn in 3.3.2.2.4.3 b).

3.3.2.2.4.7 *Point “E”*. This point is used to determine the omnidirectional entry area in the direction of the C and D axis. It is located by its coordinates XE and YE from the outline of the template:

- a) draw a line perpendicular to the inbound track at a distance XE (Table I-4-3-App C-4, line 32) from the extreme position of the outline of the template in the direction of the C axis (common tangent to the circles centred on “k” and “l”);
- b) draw a line parallel to the inbound track at a distance YE (Table I-4-3-App C-4, line 33) from the extreme position of the outline of the template in the direction of the D axis (circle centred on “n4”); and
- c) locate point “E” at the intersection of these two lines.

Explanation:

XE is the greatest displacement along the C axis of an aeroplane making an entry procedure. This occurs for a sector 3 entry at an angle of 90° with the procedure axis and a wind along the C axis (see Figure I-4-3-App C-8).

The maximum displacement along the C axis due to wind effect occurs at point E_{\max} , after that portion of turn corresponding to the drift angle. For simplicity this angle has a value of 15° in the formula.

$$XE = 2r + (t + 15)v + (11 + 90/R + t + 15 + 105/R)w'$$

YE is the greatest displacement along the D axis of an aeroplane making an entry procedure. This occurs for a sector 1 entry at an angle of 70° with the procedure axis and a wind along the D axis (see Figure I-4-3-App C-9).

The maximum displacement along the D axis due to wind effect occurs at point E_{\max} , after that portion of turn corresponding to the drift angle. For simplicity, this angle has a value of 15° in the formula.

$$YE = 11v \cos 20^\circ + r \sin 20^\circ + r + (t + 15)v \tan 5^\circ + (11 + 20/R + 90/R + t + 15 + 15/R)w'$$

3.3.3 *Second step: construction of the basic area and the associated omnidirectional entry area overhead a VOR or NDB or at the intersection of VOR radials*

3.3.3.1 *Construction of the basic area (Reference Diagram I-4-3-App C-7)*

3.3.3.1.1 *Procedure fix tolerance area*

3.3.3.1.1.1 *Procedure overhead a VOR*

- a) Locate point “A” on the VOR; and
- b) draw around “A” the position fix tolerance area of the VOR given by the template (area VI V2 V3 V4) and locate points “A1”, “A2”, “A3” and “A4” on the four corners of this area.

3.3.3.1.1.2 *Procedure overhead an NDB*

- a) Locate point “A” on the NDB; and
- b) draw around “A” the position fix tolerance area of the NDB given by the template (area NI N2 N3 N4) and locate points “A1”, “A2”, “A3” and “A4” on the four corners of this area.

3.3.3.1.1.3 *Procedure at the intersection of VOR radials*

- a) Locate point “A” at the intersection of the homing and intersecting radials; and
- b) draw around “A” the position fix tolerance area determined by the tolerances of the homing and intersecting radials Part I, Section 2, Chapter 2, 2.3.3, “System use accuracy” and locate points “A1”, “A2”, “A3” and “A4” on the four corners of this area.

3.3.3.1.2 *Construction of the procedure area*

3.3.3.1.2.1 Place the template point “a” on A3, with the template procedure axis parallel to the inbound track, and draw the curve “3” (part of the outline of the template) and the line “3” (protection of the outbound leg in the direction of the D axis).

3.3.3.1.2.2 Place the template point “a” successively on “A1”, “A2” and “A4” to draw curves “1”, “2” and “4”.

3.3.3.1.2.3 Draw the common tangents to curves “1” and “2”, “2” and “4”, “3” and “4”, “3” and “1”.

3.3.3.2 *Construction of the entry area*

3.3.3.2.1 *Construction of the entry area assuming omnidirectional entry overhead a VOR or an NDB (Reference Diagrams I-4-3-App C-8, I-4-3-App C-9 and I-4-3-App C-10)*

3.3.3.2.1.1 Draw the circle centred on “A” passing through “A1” and “A3”.

3.3.3.2.1.2 Locate point “E” on a series of points along this circle (with the template axis parallel to the inbound track) and for each point draw a curve at the outer limit of the template in the direction of the C and D axis; curve “5” is the envelope of these curves.

3.3.3.2.1.3 Draw the limit of the entry sectors 1 and 3 (line making an angle of 70° with the inbound track). With the template axis on this line, draw the entry fix tolerance area E1 E2 E3 E4 given by the template for the VOR or the NDB.

3.3.3.2.1.4 Place the template point “a” on E1 and E3 (with the template axis parallel to the separating line of the sectors 1 and 3) and draw curves “6” and “7” and their common tangent.

3.3.3.2.1.5 With a centre on “A”, draw the arc tangent to curve “6” until intersecting curve “1”.

3.3.3.2.1.6 Line 8 is the symmetric of lines 6 and 7 about the 70° dividing line. Draw common tangents to curves “5”, “6”, “7” and “8” as appropriate.

3.3.3.2.2 *Construction of the entry area assuming entries along the homing and intersecting radial in the case of a procedure based on the intersection of VOR radials (Reference Diagram I-4-3-App C-12)*

3.3.3.2.2.1 *Protection of the entry along the reciprocal of the inbound track.* Place the template point “E” on “A2” and “A4” (with the template axis parallel to the inbound track) and draw curves “5” and “6” (parts of the outline of the template) and their common tangent.

3.3.3.2.2.2 *Protection of the entries along the intersecting radial.* In addition to the area provided by the curves “5” and “6” above, if the intersecting VOR is located in sector 2 or in the part of sector 3 opposite to sector 2 the protection area is determined as follows.

3.3.3.2.2.2.1 Determine the entry fix tolerance area E1 E2 E3 E4 by applying the tolerance for a homing VOR (Part I, Section 2, Chapter 2, Table I-2-2-1) to the intersecting radial and the tolerance for an intersecting VOR (Part I, Section 2, Chapter 2, Table I-2-2-1) to the homing radial.

3.3.3.2.2.2.2 Place the template point “a” on E3 and E4 (with the template axis parallel to the intersecting radial) and draw curves “7” and “8” (protection of a turn of more than 180°: inner curve of the template) and their common tangent.

3.3.3.3 *Area reduction for a procedure overhead a facility when entries from Sector 1 are not permitted (Reference Diagram I-4-3-App C-11)*

3.3.3.3.1 If the aircraft intercepts the procedure radial before the end of the outbound leg, the pilot is assumed to follow the indications of this radial without drifting any further from the procedure axis.

3.3.3.3.2 If line 3 intersects the protection line of the procedure axis (VOR or NDB along track errors) the area may be reduced as shown on Diagram I-4-3-App C-11; rotate the template 180° and place point “a” on the protection line of the procedure axis, tangent to the area in the direction of the C axis; draw a parallel line to the protection line, tangent to the entry curve. The area under that parallel, in the direction of the D axis, may be eliminated.

3.3.3.3.3 This reduction is allowed only when entries from Sector 1 are not permitted.

3.3.4 Construction of the basic area and the associated along-the-radial entry area for VOR/DME procedure

3.3.4.1 Procedure towards the station (Reference Diagram I-4-3-App C-13)

3.3.4.1.1 Construction of the basic area

3.3.4.1.1.1 Selection and calculation of the distance parameters (see Figure I-4-3-App C-10). The distance parameters are chosen and calculated in the following sequence:

- a) choice of the nominal distance: D

D is the slant range between the VOR/DME facility and the procedure point at the specified altitude;

- b) choice of the outbound distance: ds

ds is the horizontal length of the outbound leg; ds should conform to the relationship $ds > vt$, where t is the outbound timing, as specified in Chapter 3, 3.5.5, “Outbound time” for racetrack procedures and in Part II, Section 4, Chapter 1, 1.3.2.2, “Outbound timing” for holding procedures;

- c) calculation of the horizontal distance: Ds

Ds is the distance between the VOR/DME facility (S) and the projection of the procedure point on the horizontal plane passing through S (point A)

$$D_s = \sqrt{D^2 - h_l^2}$$

(Ds, D and hl in km); or

$$D_S = \sqrt{D^2 - 0.027 h_l^2}$$

(Ds and D in NM and hl in thousands of feet)

- d) calculation of the limiting outbound distance: DL

DL is the slant range between the VOR/DME facility and the end of the outbound track at the specified altitude

$$D_L = \sqrt{(D_s + d_s)^2 + 4r^2 + h_l^2}$$

(DL, Ds, ds, r, hl in km); or

$$D_L = \sqrt{(D_s + d_s)^2 + 4r^2 + 0.027 h_l^2}$$

(DL, Ds, ds, r in NM and hl in thousands of feet)

DL is then rounded to the next higher km (or NM), unless the decimal part is less than 0.25 km (or NM) in the case of a procedure at or below 4 250 m (or 14 000 ft) or 0.5 km (or NM) in the case of a procedure above 4 250 m (or 14 000 ft), in which case it is rounded to the next lower km (or NM);

- e) calculation of the horizontal limiting outbound distance: DLs

DLs is the distance between the VOR/DME facility and the vertical projection of the end of the outbound track onto the horizontal plane passing through S

$$DLs = \sqrt{DL^2 - hl^2}$$

(DLs, DL, hl in km); or

$$DLs = \sqrt{DL^2 - 0.027 hl^2}$$

(DLs, DL in NM and hl in thousands of feet)

3.3.4.1.1.2 Fix tolerance area and limiting outbound distance

- a) Draw from S the procedure radial “RP” and two lines “RP1” and “RP2” making an angle (tolerance for a homing VOR, Part I, Section 2, Chapter 2, Table I-2-2-1) with RP on each side of it;
- b) with a centre on S, draw arcs “Ds” with a radius Ds, “D1” with a radius Ds – dl, “D2” with a radius Ds + dl, “DLs”, “DL1” and “DL2” with radii DLs, DLs – d2 and DLs + d2

where dl and d2 are the DME tolerance associated with D and DL:

dl is 0.46 km (0.25 NM) + 0.0125 D;

d2 is 0.46 km (0.25NM) + 0.0125 DL

- c) locate points “A” at the intersection of “RP” and “Ds”
 “A1” and “A2” at the intersections of “RP1”
 with “D1” and “D2”
 “A3” and “A4” at the intersections of “RP2”
 with “D1” and “D2”.

3.3.4.1.1.3 Protection of the outbound turn and outbound leg

- a) Place racetrack template point “a” on A1, with axis parallel to the inbound track, and draw curve “1” (part of the outline of the template);
- b) place template point “a” on A3, with axis parallel to the inbound track, and draw curve “2” (part of the outline of the template) and line “3” (protection of the outbound leg on the non-maneuvring side); and
- c) draw the common tangent to curves “1” and “2” and extend the straight part of curve “1” and the line “3” in the direction of the outbound end.

3.3.4.1.1.4 Area containing the end of the outbound leg

- a) Locate points C1 and C’3 at the intersection of the extension of curve “1” with the arcs DL1 and DL2;
- b) locate point C2 between C1 and C’3 at a distance (dl + d2 – 0.93) km or (dl + d2 – 0.5) NM from C’3;
- c) draw a parallel line to the inbound track through C2 and locate points C3 at the intersection of this line with arc DL2;

- d) do the same thing as in a), b) and c) with the line “3” instead of curve “1” and points C4, C’6, C5 and C6 instead of C1, C’3, C2 and C3 (see Figure I-4-3-App C-11 a)); and
- e) if the aircraft intercepts the VOR radial before reaching the limiting outbound distance, the pilot is assumed to follow the indications of the VOR without drifting any further from the procedure axis, so:

where C5 and C6 are further from the procedure axis than RP2 (see Figure I-4-3-App C-11 b)), replace C5 and C6 by the intersections of RP2 with line “3” and DL2, and the end of the outbound leg is contained in the area C1, C2, C3, C4, C5 and C6; and

where C4, C5 and C6 are further from the procedure axis than RP2 (see Figure I-4-3-App C-11 c)), replace C4 and C6 by the intersections of RP2 with DL1 and DL2, and the end of the outbound leg is contained in the area C1, C2, C3, C4 and C6.

3.3.4.1.1.5 *Protection of the inbound turn.* Rotate the template 180°, then:

- a) place template point “a” on C2 and C3, with axis parallel to the inbound track, and draw curves “4” and “5” (part of the protection line of a turn of more than 180°) and their common tangent;
- b) move the template point “a” along arc DL2 from C3 to C6 (with axis parallel and opposite to the inbound track) and draw curve “6”;
- c) place template point “a” on C6, C4 and eventually on C5 and draw curves “7”, “8” and eventually “9” and their common tangent; and
- d) draw the tangent to curves “8” and “2”.

3.3.4.1.2 *Construction of the entry areas*

3.3.4.1.2.1 *Arrival to a VOR/DME holding pattern may be:*

- along the axis of the inbound track;
- along a published track;
- by radar vectoring, when aircraft must be established on prescribed protected flight paths;

and the entry point may be either:

- a) the holding fix; or
- b) the fix at the end of the outbound leg.

When the entry point is at the holding fix, two cases may be considered:

Case 1.1 — arrival via the VOR radial for the inbound leg;

Case 1.2 — arrival via the DME arc defining the holding fix.

When the entry point is at the fix at the end of the outbound leg, the only case is arrival via the VOR radial passing through the fix at the end of the outbound leg.

3.3.4.1.2.2 It is also possible to make use of guidance from another radio facility (e.g. NDB); in that case, protection of the entry should be the subject of a special study based on general criteria.

3.3.4.1.2.3 The radius of a DME arc used as guidance for arrival at a VOR/DME holding should be not less than 18.5 km (10 NM).

3.3.4.1.2.4 The minimum length for the last segment of the arrival track terminating at the entry point is a function of the angle (θ) between the penultimate segment or radar path and the last segment. The values are shown in the following table:

	θ			
	0° – 70°	71° – 90°	91° – 105°	106° – 120°
Minimum distance in km (NM)	7.5 (4)	9.5 (5)	13 (7)	16.5 (9)

3.3.4.1.2.5 *Method of arrival at a VOR/DME holding and the corresponding entry procedures.* The methods are described in more detail as follows:

Case 1 — entry at the holding fix;

Case 1.1 — entry at the holding fix via a radial forming the fix:

- a) *Arrival on the VOR radial for the inbound leg, on the same heading as the inbound track.* The arrival path (or last segment thereof) is aligned with the inbound track and follows the same heading. The entry consists of following the holding pattern (see Figure I-4-3-App C-12 a)).

Protection of the entry: The entry is protected by the holding protection area.

- b) *Arrival on the VOR radial for the inbound leg, on a heading reciprocal to the inbound track.* On arrival over the holding fix, the aircraft turns onto the holding side on a track making an angle of 30° with the reciprocal of the inbound track, until reaching the DME outbound limiting distance, at which point it turns to intercept the inbound track. In the case of a VOR/DME holding entry away from the facility with a limiting radial, if the aircraft encounters the radial ahead of the DME distance, it must turn and follow it until reaching the DME outbound limiting distance, at which point it turns to join the inbound track (see Figure I-4-3-App C-12 b)).

Case 1.2 — entry at the holding fix via the DME arc forming the fix:

- a) *Arrival on the DME arc defining the holding fix, from the holding side.* On arrival over the holding fix, the aircraft turns and follows a track parallel to and reciprocal to the inbound track, until reaching the DME limiting outbound distance, at which point it turns to intercept the inbound track (see Figure I-4-3-App C-12 c)).
- b) *Arrival on the DME arc defining the holding fix, from the non-holding side.* On arrival over the holding fix, the aircraft turns and follows a track parallel to and on the same heading as the outbound track, until reaching the DME outbound limiting distance, at which point it turns to intercept the inbound track (see Figure I-4-3-App C-12 d)).

An arrival track leading to a Case 1.2 a) entry should not be specified unless absolutely necessary, particularly in a VOR/DME holding procedure away from the facility. If an appropriate DME distance is chosen, this type of arrival can actually be replaced by one on a DME arc terminating in the extension of the inbound track (see Figures I-4-3-App C-12 e) and f)).

Case 2 — entry at the fix at the end of the outbound leg via a radial forming the limiting fix:

- a) outbound from the facility;
- b) inbound from the facility.

On arrival over the fix at the end of the outbound leg, the aircraft turns and follows the holding pattern.

3.3.4.1.2.6 The sector 1 entry along the DME arc is protected as follows:

- a) take a tracing of the template, turn it over and place point “a” on A3 with axis on the line A1, A3 to draw curve “13”;
- b) draw the line “14” parallel to line “3” (used in the construction of the basic area) and tangent to curve “13”, and locate point C10 at the intersection of this line with arc DL2;
- c) place point “a” of the tracing on C10, with axis parallel and opposite to the inbound track and move it along DL2 up to the intersection of DL2 and RP1 to draw curve “15”.

3.3.4.1.2.7 *Protection of sector 2 entry procedure*

3.3.4.1.2.7.1 It is assumed that having passed the fix, the pilot makes good ($\pm 5^\circ$ error) a track making an angle of 30° with the inbound track on the manoeuvring side and reaching the limiting outbound distance, turns inbound. In addition, the flying time on the 30° offset track is limited to 1 min 30 s after which the pilot is expected to turn to a heading parallel to the outbound track until reaching the limiting outbound distance, where the pilot turns inbound.

3.3.4.1.2.7.2 For a procedure with outbound of more than 1 min 30 s the protection of sector 2 entry procedure is assured by the basic area.

3.3.4.1.2.7.3 For a procedure with outbound of 1 min or 1 min 30 s, the protection area of sector 2 entry is drawn as follows:

- a) from A1 draw a line making an angle of $30^\circ + 5^\circ$ with RP and locate C7 at its intersection with DL2;
- b) from A4 draw a line making an angle of $30^\circ - 5^\circ$ with RP and locate C8 at its intersection with DL2;
- c) place template point “a” on C7 and move it along DL2 to C8, with axis making an angle of 30° with RP, to draw curve “11”;
- d) draw the common tangents to the curves “10” and “11” and to the basic area.

3.3.4.1.3 *Construction of the entry area for a reciprocal direct entry to a secondary point*
(Reference Diagram I-4-3-App C-14)

3.3.4.1.3.1 It is assumed that reciprocal direct entries are made along the entry radial (RE) joining the VOR/DME station (S) to the secondary point (I) where the turn to inbound is initiated.

3.3.4.1.3.2 This direct entry area is drawn as follows:

- a) measure the angle made by the procedure radial (RP) and the radial joining the VOR/DME station to the end of the nominal outbound leg (line SC) and round its value to the nearest entire degree to obtain the entry radial (RE) to be published;

- b) locate point “I” at the intersection of RE and DLs;
- c) from S draw the lines “RE1” and “RE2” making an angle α (tolerance for homing VOR; Part I, Section 2, Chapter 2, Table I-2-2-1) with RE on each side of it;
- d) locate points “I1” and “I2” at the intersections of RE1 with DL1 and DL2 and points “I3” and “I4” at the intersections of RE2 with DL1 and DL2; and
- e) place template point “a” on I2, with axis parallel to RE and move it along DL2 from I2 to I4 to draw curve “13”.

3.3.4.2 *Procedure away from the station*
(Reference Diagram I-4-3-App C-15)

3.3.4.2.1 *Construction of the basic area*

3.3.4.2.1.1 *Selection and calculation of the distance parameters* (see Figure I-4-3-App C-13). The distance parameters are chosen and calculated in the following sequence:

- a) choice of the nominal distance: D

D is the slant range between VOR/DME facility and the procedure point at the specified altitude;

- b) choice of the outbound distance: ds

ds is the horizontal length of the outbound leg

ds should conform to the relationship $ds \geq vt$, where t is the outbound timing, as specified in Chapter 3, 3.5.5, “Outbound time” for racetrack procedures and in Part II, Section 4, Chapter 1, 1.3.2.2, “Outbound timing”, for holding procedures;

- c) calculation of the horizontal distance: Ds

Ds is the distance between the VOR/DME facility (S) and the vertical projection of the procedure point on the horizontal plane through S

$$D_s = \sqrt{D^2 - h^2}$$

(Ds, D and h in km); or

$$D_S = \sqrt{D^2 - 0.027 h^2}$$

(Ds and D in NM and h in thousands of feet)

- d) calculation of the limiting outbound distance: DL

DL is the slant range between the VOR/DME facility and the end of the outbound track at the specified altitude

$$DL = \sqrt{(D_s - ds)^2 + 4r^2 + h^2}$$

(DL, Ds, ds, r, hl in km); or

$$DL = \sqrt{(Ds - ds)^2 + 4r^2 + 0.027 hl^2}$$

(DL, Ds, ds, r in NM and hl in thousands of feet)

DL is then rounded to the next lower km or NM, unless the decimal part is greater than 0.25 km or NM in the case of a procedure at or below 4 250 m (or 14 000 ft) or 0.5 km or NM in the case of a procedure above 4 250 m (or 14 000 ft), in which case it is rounded to the next higher km or NM;

- e) calculation of the horizontal limiting outbound distance: DLs

DLs is the distance between the VOR/DME facility and the vertical projection of the end of the outbound track onto the horizontal plane passing through S

$$DLs = \sqrt{DL^2 - hl^2}$$

(DL, hl in km); or

$$DLs = \sqrt{DL^2 - 0.027 hl^2}$$

(DLs, DL in NM and hl in thousands of feet)

3.3.4.2.1.2 *Fix tolerance area and limiting outbound distance*

- Draw from S the procedure radial “RP” and two lines, “RP1” and “RP2”, making an angle α (tolerance for a homing VOR, Part I, Section 2, Chapter 2, Table I-2-2-1) with RP on each side of it;
- with a centre on S, draw arcs “Ds” with a radius Ds, “D1” with a radius Ds + d1, “D2” with a radius Ds – d1, “DLs”, “DL1” and “DL2” with radii DLs, DLs + d2 and DLs – d2

where d1 and d2 are the DME tolerances associated with D and DL:

d1 is 0.46 km (0.25 NM) + 0.0125 D; and

d2 is 0.46 km (0.25 NM) + 0.0125 DL; and

- locate points “A” at the intersection of RP and Ds:
 “A1” and “A2” at the intersections of RP1 with D1 and D2; and
 “A3” and “A4” at the intersections of RP2 with D1 and D2.

3.3.4.2.1.3 *Protection of the outbound turn and outbound leg*

- Place template point “a” on A1, with axis parallel to the inbound track, and draw curve “1” (part of the outline of the template);

- b) place template point “a” on A3, with axis parallel to the inbound track, and draw curve “2” (part of the outline of the template) and line “3” (protection of the outbound leg in the direction of the non-maneuvring side); and
- c) draw the common tangent to curves “1” and “2” and extend the straight part of curve “1” and the line “3” in the direction of the outbound end.

3.3.4.2.1.4 Area containing the end of the outbound leg

- a) Locate points C1 and C’3 at the intersections of the extensions of curve “1” with the arcs DL1 and DL2. If no intersection occurs a limiting radial shall be specified (see 3.3.4.3 of this appendix);
- b) locate point C2 between C1 and C’3 at a distance $(d1 + d2 - 0.93)$ km or $(d1 + d2 - 0.5)$ NM from C’3;
- c) draw a parallel line to the inbound track through C2 and locate point C3 at the intersection of this line with arc DL2;
- d) do the same thing as in a), b) and c) above, with the line “3” instead of curve “1” and points C4, C’6, C5 and C6 instead of C1, C’3, C2 and C3 (see Figure I-4-3-App C-14 a)); and
- e) if the aeroplane intercepts the VOR radial before reaching the limiting outbound distance, the pilot is assumed to follow the indications of the VOR without drifting any further from the procedure axis, so:

where C5 and C6 are further from the procedure axis than RP2 (see Figure I-4-3-App C-14 b)), replace C5 and C6 by the intersections of RP2 with line “3” and DL2, and the end of the outbound leg is contained in the area C1, C2, C3, C4, C5, and C6;

where C4, C5 and C6 are further from the procedure axis than RP2 (see Figure I-4-3-App C-14 c)), replace C4 and C6 by the intersections of RP2 with DL1 and DL2, and the end of the outbound leg is contained in the area C1, C2, C3, C4, and C6.

3.3.4.2.1.5 Protection of the inbound turn. Rotate the template 180°, then:

- a) place template point “a” on C2 and C3, with axis parallel to the inbound track, and draw curves “4” and “5” (part of the protection line of a turn of more than 180°) and their common tangent;
- b) move the template point “a” along arc DL2 from C3 to C6, with axis parallel to the inbound track, and draw curve “6”;
- c) place template point “a” on C6, C4 and eventually on C5 and draw curves “7”, “8” and eventually “9” and their common tangents; and
- d) draw the tangent to curves “8” and “2”.

3.3.4.2.2 *Construction of the entry area.* It is assumed that all entries are executed along the VOR radial or the DME arc defining the fix. The entries made along the radial inbound to the fix or along the DME arc from the non-maneuvring side are protected by the basic area. The protection of the entries made along the reciprocal to inbound or along the DME arc from the manoeuvring side needs, in addition to the basic area, the area constructed as follows. The entry along the DME arc from the manoeuvring side is a sector 1 entry procedure. As the reciprocal to the inbound track is the dividing line between entry sectors 1 and 2, it is assumed that both sector 1 and sector 2 entry procedures may be executed when entering along the reciprocal to inbound.

3.3.4.2.2.1 *Protection of sector 1 entry procedure.* When entering along the DME arc, it is assumed that having passed the fix the aircraft turns and follows a track parallel to the inbound track and on reaching the DME limiting outbound distance, turns inbound onto the manoeuvring side. For entries along the DME arc, the entry area is drawn as follows:

- a) take a tracing of the template, turn it over and place point “a” on A3 with axis on the line A1 A3 to draw curve “14”;
- b) draw the line “15” parallel to line “3” (used in the construction of the basic area) and tangent to curve “14”, and locate point C10 at the intersection of this line with arc DL2; and

Note.— If no intersection occurs, either the specified DME distances should be adjusted or the sector 1 entry along the DME arc shall not be allowed.

- c) place point “a” of the tracing on C10, with axis parallel and opposite to the inbound track, and move it along DL2 up to the intersection of DL2 and RP1 to draw curve “16”.

3.3.4.2.2.2 *Protection of sector 2 entry procedure.* It is assumed that having passed the fix, the pilot makes good (with $\pm 5^\circ$ error) a track making an angle of 30° with the inbound track on the manoeuvring side and reaching the limiting outbound distance, turns inbound. In addition, the flying time on the 30° offset track is limited to 1 min 30 s after which the pilot is expected to turn to a heading parallel to the outbound track until reaching the limiting outbound distance, where the pilot turns inbound.

3.3.4.2.2.2.1 For a procedure with outbound of more than 1 min 30 s the protection of sector 2 entry procedure is assured by the basic area.

3.3.4.2.2.2.2 For a procedure with outbound of 1 min or 1 min 30 s, the protection area of sector 2 entry is drawn as follows:

- a) from A1 draw a line making an angle of $30^\circ + 5^\circ$ with RP and locate C7 at its intersection with DL2. If no intersection occurs, a limiting radial must be specified according to 3.3.4.3;
- b) from A4 draw a line making an angle of $30^\circ - 5^\circ$ with RP and locate C8 at its intersection with DL2;
- c) place template point “a” on C7 and move it along DL2 to C8, with axis making an angle of 30° with RP, to draw curve “10”; and
- d) draw the common tangents to the curve “10” and to the basic area.

3.3.4.2.3 *Construction of the entry area for a reciprocal direct entry to a secondary point* (Reference Diagram I-4-3-App C-16)

3.3.4.2.3.1 The reciprocal direct entry is made along the entry radial (RE) joining the VOR/DME station (S) to the secondary point (I) where the turn to inbound is initiated.

3.3.4.2.3.2 The protection of this entry procedure is assured by the basic area.

3.3.4.2.3.3 The entry radial is determined as follows: Measure the angle made by the procedure radial (RP) and the radial joining the VOR/DME station to the end of the nominal outbound leg (line SC) and round its value to the nearest entire degree to obtain the entry radial (RE) to be published.

3.3.4.3 Procedure away from the station with a limiting radial (Reference Diagram I-4-3-App C-17)

3.3.4.3.1 Construction of the basic area

3.3.4.3.1.1 *Selection and calculation of the distance parameters (see Figure I-4-3-App C-13).* The distance parameters are chosen and calculated in the same manner as in 3.3.4.2.1.1 above.

3.3.4.3.1.2 *Fix tolerance area, limiting outbound distance and limiting radial.* The fix tolerance area and the limiting outbound distance are drawn in the same manner as in 3.3.4.2.1.2:

- a) place template point “a” on A2 and locate the point “R” given by the template;
- b) measure the angle between the line joining R and S and RP, add (tolerance for an intersecting VOR, see Part I, Section 2, Chapter 2, Table I-2-2-1) and round the result to the next higher degree; and
- c) from S draw line RL making an angle of the rounded value of c) with RP and line RL2 making the angle β with RL.

3.3.4.3.1.3 *Protection of the outbound turn and outbound leg.* Protection of the outbound turn and outbound leg is drawn in the same manner as in 3.3.4.2.1.3 above.

3.3.4.3.1.4 Area containing the end of the outbound leg

- a) If the intersection of extension of curve 1 and RL2 is nearer to A1 than the intersection of extension of curve 1 and DL1 (case of Diagram I-4-3-App C-17), locate point C1 at the intersection of extension of curve 1 with line RL2 and C2 and C3 at the intersections of RL2 with DL1 and DL2;
- b) if the intersection of extension of curve 1 and RL2 is between the intersections of the same extension with DL1 and DL2, locate points C1 and C2 at the intersections of the extension of curve 1 with arc DL1 and line RL2 and point C3 at the intersection of RL2 with DL2;
- c) if the intersection of extension of curve 1 and RL2 is further from A1 than the intersection of the same extension with DL2, do the same as in 3.3.4.2.1.4 a), b) and c); and
- d) locate points C4, C6 and eventually C5 in the same manner as explained in 3.3.4.2.1.4 d) and e).

3.3.4.3.1.5 Protection of the inbound turn. Rotate the template 180°, then:

- a) place the template point “a” on C1, C2 and C3, with axis parallel to the inbound track, and draw curves “4”, “5” and “6” (part of the protection line of a turn of more than 180°) and their common tangents;
- b) move template point “a” along arc DL2 from C3 to C6, with axis parallel to the inbound track, and draw curve “7”;
- c) place template point “a” on C6, C4 and eventually on C5, with axis parallel to the inbound track, and draw curves “8”, “9” and eventually “10” and their common tangents; and
- d) draw the tangent to curves “9” and “2”.

3.3.4.3.2 Construction of the entry area

3.3.4.3.2.1 *Protection of sector 1 entry procedures.* For the protection of sector 1 entry procedure see 3.3.4.2.2.1 above.

3.3.4.3.2.2 *Protection of sector 2 entry procedures.* It is assumed that having passed the fix, the pilot makes good a track (with $\pm 5^\circ$ error) making an angle of 30° with the inbound track on the manoeuvring side and reaching the limiting outbound distance, turns inbound. In addition, the flying time on the 30° offset track is limited to 1 min 30 s after which the pilot is expected to turn a heading parallel to the inbound track until reaching the limiting outbound distance, where the pilot turns inbound.

3.3.4.3.2.2.1 For a procedure with outbound of more than 1 min 30 s the protection of sector 2 entry procedure is assured by the basic area.

3.3.4.3.2.2.2 For a procedure with outbound of 1 min or 1 min 30 s, the protection area of sector 2 entry is drawn as follows:

- a) from A1 draw a line making an angle of $30^\circ + 5^\circ$ with RP and locate C7 at its intersection with DL2 or RL2, whichever is the nearer to A1;
- b) from A4 draw a line making an angle of $30^\circ - 5^\circ$ with RP and locate C8 at its intersection with DL2;
- c) place template point “a” on C7, with axis making an angle of 30° with RP, and draw curve “11” (part of the protection line of a turn of more than 180°);
- d) move template point “a” from C7 to C8 along arc DL2, or along line RL2 and then arc DL2 if C7 is on RL2, keeping the axis of the template making an angle of 30° with RP, to draw curve “12”; and
- e) draw the common tangents to the curves “11” and “12” and to the basic area.

3.4 Area reduction for holding and racetrack procedures

3.4.1 *Area reduction by use of DME or limiting radial/bearing.* If a DME distance or an intersection of radial or bearing is used to limit the outbound leg of a procedure, the area may be reduced by applying the racetrack or holding template for the altitude in question in the following way:

- a) construct the protection area in accordance with 3.3;
- b) with the centre on S (= position of the DME station) draw arcs “DL” and “DL2” on the end of the outbound leg. The radius DL is the distance from S to the end of the nominal outbound legs. The radius DL2 is DL plus DME tolerance d2; d2 is 0.46 km (0.25 NM) + 0.0125 DL;
- c) from S (= position of VOR or NDB) draw line “RL” through the end of the nominal outbound leg representing the intersecting radial or bearing. Draw line “RL2” by adding the respective tolerance of the intersecting facility (Part I, Section 2, Chapter 2, 2.3); and
- d) place template point “a” on the intersection of “DL2” or “RL2” with the boundary of the protection area constructed in a).

The axis of the template has to be parallel to the nominal outbound track. Move template point “a” along “DL2” or “RL2” respectively drawing curve “R”. The area between curve “R” and the outbound end of the area protected in accordance with a) can be deleted (see Figure I-4-3-App C-15).

3.4.2 *Area reduction for racetrack or holding procedures by limitation of entry routes.* If entry to a procedure is restricted to entry along the inbound radial, the basic area may be used without the additional areas required for omnidirectional entry (see examples in Figures I-4-3-App C-16 and I-4-3-App C-17).

3.5 Simplified area construction method for reversal and racetrack procedures

3.5.1 *General.* Reversal and racetrack procedure areas may be defined by simple rectangles. The dimensions of the rectangle for each type of procedure may easily be calculated from the equations given in this section. The rectangle will, in all cases, include or be slightly larger than the area constructed using the more detailed TTT method. The TTT method should be used to obtain maximum benefit wherever airspace is critical.

3.5.2 *Frame of reference.* The dimensions of the rectangles are related to a conventional x, y coordinate system, with its origin at the facility (see Figure I-4-3-App C-18). The x axis is parallel to the inbound track. Negative values of x are measured from the facility in the direction of the inbound track, positive values are measured from the facility against the direction of the inbound track. Positive values of y are measured on that side of the x axis containing the outbound track or manoeuvre of the reversal procedure/racetrack. The y axis is at right angles to the x axis.

3.5.3 *Area calculation.*

- a) Decide the values of IAS and height for the reversal/racetrack procedure. Calculate the TAS at ISA + 15°C for the specified height (Part I, Section 2, Chapter 1, Appendix). Calculate the wind speed (ICAO or statistical wind for the height specified).
- b) Decide the type of procedure required:
 - Procedure turn (45/180) — Table I-4-3-App C-5 a)
 - Procedure turn (80/260) — Table I-4-3-App C-5 b)
 - Base turn — Table I-4-3-App C-5 c)
 - Racetrack — Table I-4-3-App C-5 d).
- c) Note the equations from Table I-4-3-App C-5.
- d) Substitute the values of TAS and wind speed calculated in a) above into the equations and calculate the required x and y values.
- e) Adjust the values to account for fix tolerance.
- f) Plot the area rectangle to the scale required.
- g) Add the appropriate buffer area.

Table I-4-3-App C-1. Calculations associated with the construction of the base turn template

	DATA	
	SI UNITS	NON-SI UNITS
IAS	260 km/h	140 kt
Altitude	1 850 m	6 000 ft
T	2 min	2 min
NDB	at 0 m	at 0 ft
Temperature	ISA + 15°C	ISA + 15°C

Line	Parameter	CALCULATIONS USING SI UNITS		CALCULATIONS USING NON-SI UNITS	
		Formula	Value	Formula	Value
1	K	Conversion factor for 1 850 m and ISA + 15°C (see Part I, Section 2, Chapter 1, Appendix)	1.1244	Conversion factor for 6 000 ft and ISA + 15°C (see Part I, Section 2, Chapter 1, Appendix)	1.1231
2	V	$V = K \times \text{IAS}$	292.34 km/h	$V = K \times \text{IAS}$	157.23 kt
3	v	$v = V \div 3\,600$	0.0812 km/s	$v = V \div 3\,600$	0.0437 NM/s
4	R	$R = 943.27 \div V$, or $3^\circ/\text{s}$, whichever is less	(3.23) $3^\circ/\text{s}$	$R = 509.26 \div V$, or $3^\circ/\text{s}$, whichever is less	(3.24) $3^\circ/\text{s}$
5	r	$r = V \div 62.83 R$	1.55 km	$r = V \div 62.83 R$	0.83 NM
6	h	in thousands of metres	1.85	in thousands of feet	6
7	w	$w' = 12h + 87$	109.2 km/h	$w = 2h + 47$	59 kt
8	w'	$w' = w \div 3\,600$	0.03 km/s	$w' = w \div 3\,600$	0.0164 NM/s
9	E	$E = w' \div R$	0.01 km/°	$E = w' \div R$	0.00546 NM/°
10	ϕ	for $V \leq 315$ km/h: $\theta = 36 \div T$ for $V > 315$ km/h: $\theta = 0.116 V \div T$	18°	for $V \leq 170$ kt: $\phi = 36 \div T$ for $V > 170$ kt: $\phi = 0.215 V \div T$	18°
11	zN	$*zN = h \tan 40^\circ$	1.55 km	$**zN = 0.164 h \tan 40^\circ$	0.83 NM
12	t	$t = 60T$	120 s	$t = 60T$	120 s
13	L	$L = vt$	9.74 km	$L = vt$	5.24 NM
14	ab1 = ab3	$***ab1 = ab3 = (t - 5)(v - w') - zN$	4.34 km	$***ab1 = ab3 = (t - 5)(v - w') - zN$	2.31 NM
15	ab2 = ab4	$***ab2 = ab4 = (t + 21)(v + w') + zN$	17.23 km	$***ab2 = ab4 = (t + 21)(v + w') + zN$	9.30 NM
16	$W_d = W_g$	$W_d = W_g = 50 E$	0.5 km	$W_d = W_g = 50 E$	0.27 NM
17	$W_e = W_f = W_h$	$W_e = W_f = W_h = 100 E$	1.0 km	$W_e = W_f = W_h = 100 E$	0.55 NM
18	W_i	$W_i = 190 E$	1.9 km	$W_i = 190 E$	1.04 NM
19	W_j	$W_j = 235 E$	2.35 km	$W_j = 235 E$	1.28 NM

		CALCULATIONS USING SI UNITS		CALCULATIONS USING NON-SI UNITS	
Line	Parameter	Formula	Value	Formula	Value
20	drift angle d	$d = \arcsin (w \div V)$	23°	$d = \arcsin (w \div V)$	23°
21	N_{3l}	$N_{3l} = 11 v$	0.9 km	$N_{3l} = 11 v$	0.48 NM
22	W_l	$W_l = 11 w'$	0.33 km	$W_l = 11 w'$	0.18 NM
23	W_m	$W_m = W_l + 50 E$	0.83 km	$W_m = W_l + 50 E$	0.45 NM
24	W_n	$W_n = W_l + 100 E$	1.33 km	$W_n = W_l + 100 E$	0.73 NM
<p>* In case of a VOR base turn, line 11 reads $zV = h \tan 50^\circ$.</p> <p>** In case of a VOR base turn, line 11 reads $zV = 0.164 h \tan 50^\circ$.</p> <p>*** In case of VOR/DME base turn, where D is the specified DME distance limiting the outbound leg and d1 is the tolerance of the DME indication (d1 is 0.46 km (0.25 NM) + 0.0125 D), lines 14 and 15 read: $ab1 = ab3 = D - d1 + 5 (v - w')$ $ab2 = ab4 = D + d1 + 11 (v + w')$</p> <p>In case of a VOR base turn, lines 14 and 15 read: $ab1 = ab3 = (t - 5) (v - w)' - zV$ $ab2 = ab4 = (t + 21) (v + w)' + zV$</p>					

Table I-4-3-App C-2. Calculations associated with the construction of the 45°-180° procedure turn template

	DATA	
	SI UNITS	NON-SI UNITS
IAS	260 km/h	140 kt
Altitude	1 850 m	6 000 ft
T	60 s (1 min for Cat A and B; 1.25 min for Cat C, D and E)	60 s (1 min for Cat A and B; 1.25 min for Cat C, D and E)
Temperature	ISA + 15°C	ISA + 15°C

Line	Parameter	CALCULATIONS USING SI UNITS		CALCULATIONS USING NON-SI UNITS	
		Formula	Value	Formula	Value
1	K	Conversion factor for 1 850 m and ISA + 15°C (see Part I, Section 2, Chapter 1, Appendix)	1.1244	Conversion factor for 6 000 ft and ISA + 15°C (see Part I, Section 2, Chapter 1, Appendix)	1.1231
2	V	$V = K \text{ IAS}$	292.34 km/h	$V = K \text{ IAS}$	157.23 kt
3	v	$v = V \div 3\,600$	0.0812 km/s	$v = V \div 3\,600$	0.0437 NM/s
4	R	$R = 943.27 \div V$, or 3°/s, whichever is less	(3.23) 3°/s	$R = 509.26 \div V$, or 3°/s, whichever is less	(3.24) 3°/s
5	r	$r = V \div 62.83 R$	1.55 km	$r = V \div 62.83 R$	0.83 NM
6	h	in thousands of metres	1.85	in thousands of feet	6
7	w	$w = 12h + 87$	109.2 km/h	$w = 2h + 47$	59 kt
8	w'	$w' = w \div 3\,600$	0.03 km/s	$w' = w \div 3\,600$	0.0164 NM/s
9	E	$E = w' \div R$	0.01 km/°	$E = w' \div R$	0.00546 NM/°
10	ab	$ab = 5v$	0.41 km	$ab = 5v$	0.22 NM
11	cd	$cd = (t - 5 - 45 \div R) v$	3.25 km	$cd = (t - 5 - 45 \div R) v$	1.75 NM
12	cd1, cd3	$cd1 = cd3 = cd - 5v$	2.84 km	$cd1 = cd3 = cd - 5v$	1.53 NM
13	cd2, cd4	$cd2 = cd4 = cd + 15v$	4.47 km	$cd2 = cd4 = cd + 15v$	2.41 NM
14	W _c	$W_c = 5w' + 45 E$	0.60 km	$W_c = 5w' + 45 E$	0.33 NM
15	W _{d2} , W _{d4}	$W_{d2} = W_{d4} = (t + 15) w'$	2.25 km	$W_{d2} = W_{d4} = (t + 15) w'$	1.23 NM
16	W _f	$W_f = W_{d2} + 50 E$	2.75 km	$W_f = W_{d2} + 50 E$	1.50 NM
17	W _g , W _h	$W_g = W_h = W_{d2} + 100 E$	3.25 km	$W_g = W_h = W_{d2} + 100 E$	1.78 NM
18	W _i	$W_i = W_{d2} + 150 E$	3.75 km	$W_i = W_{d2} + 150 E$	2.05 NM
19	W _j	$W_j = W_{d2} + 200 E$	4.25 km	$W_j = W_{d2} + 200 E$	2.32 NM
20	W _k	$W_k = (t - 5)w' + 200 E$	3.65 km	$W_k = (t - 5)w' + 200 E$	1.99 NM
21	W _l	$W_l = W_k + 50 E$	4.15 km	$W_l = W_k + 50 E$	2.27 NM

Table I-4-3-App C-3. Calculations associated with the construction of the 80°-260° procedure turn template

	DATA	
	SI UNITS	NON-SI UNITS
IAS	405 km/h	220 kt
Altitude	1 850 m	6 000 ft
Temperature	ISA + 15°C	ISA + 15°C

Line	Parameter	CALCULATIONS USING SI UNITS		CALCULATIONS USING NON-SI UNITS	
		Formula	Value	Formula	Value
1	K	Conversion factor for 1 850 m and ISA + 15°C (see Part I, Section 2, Chapter 1, Appendix)	1.1244	Conversion factor for 6 000 ft and ISA + 15°C (see Part I, Section 2, Chapter 1, Appendix)	1.1231
2	V	$V = K \times \text{IAS}$	455.38 km/h	$V = K \times \text{IAS}$	247.08 kt
3	v	$v = V \div 3\,600$	0.1265 km/s	$v = V \div 3\,600$	0.0686 NM/s
4	R	$R = 943.27 \div V$, or 3°/s, whichever is less	2.07°/s	$R = 509.26 \div V$, or 3°/s, whichever is less	2.06°/s
5	r	$r = V \div 62.83 R$	3.5 km	$r = V \div 62.83 R$	1.91 NM
6	h	in thousands of metres	1.85	in thousands of feet	6
7	w	$w = 12h + 87$	109.2 km/h	$w = 2h + 47$	59 kt
8	w'	$w' = w \div 3\,600$	0.03 km/s	$w' = w \div 3\,600$	0.0164 NM/s
9	E	$E = w' \div R$	0.0145 km/°	$E = w' \div R$	0.00796 NM/°
10	ab	$ab = 5v$	0.63 km	$ab = 5v$	0.34 NM
11	d _e , d _{1e1} , d _{2e2}	$d_e = d_{1e1} = d_{2e2} = 10v$	1.27 km	$d_e = d_{1e1} = d_{2e2} = 10v$	0.69 NM
12	W _{e2}	$W_{e2} = 15w' + 85 E$	1.68 km	$W_{e2} = 15w' + 85 E$	0.92 NM
13	W _g	$W_g = 15w' + 130 E$	2.34 km	$W_g = 15w' + 130 E$	1.28 NM
14	W _h	$W_h = 15w' + 175 E$	2.99 km	$W_h = 15w' + 175 E$	1.64 NM
15	W _i	$W_i = 15w' + 220 E$	3.64 km	$W_i = 15w' + 220 E$	2.00 NM
16	W _j	$W_j = 15w' + 265 E$	4.29 km	$W_j = 15w' + 265 E$	2.36 NM
17	W _k	$W_k = 15w' + 255 E$	4.15 km	$W_k = 15w' + 255 E$	2.28 NM
18	W _l	$W_l = 15w' + 300 E$	4.80 km	$W_l = 15w' + 300 E$	2.63 NM
19	W _m	$W_m = 15w' + 345 E$	5.45 km	$W_m = 15w' + 345 E$	2.99 NM

Table I-4-3-App C-4. Calculations associated with the construction of the holding and racetrack template

	DATA	
	SI UNITS	NON-SI UNITS
IAS	405 km/h	220 kt
Altitude	3 050 m	10 000 ft
T	1 min	1 min
Temperature	ISA + 15°C	ISA + 15°C

Line	Parameter	CALCULATIONS USING SI UNITS		CALCULATIONS USING NON-SI UNITS	
		Formula	Value	Formula	Value
1	K	Conversion factor for 3 050 m and ISA + 15°C (see Part I, Section 2, Chapter 4, Appendix)	1.1960	Conversion factor for 10 000 ft and ISA + 15°C (see Part I, Section 2, Chapter 4, Appendix)	1.1958
2	V	$V = K \times \text{IAS}^*$	484.38 km/h	$V = K \times \text{IAS}^*$	263.08 kt
		* The true airspeed may also be deduced from Part II, Section 4, Chapter 1, Appendix A.		* The true airspeed may also be deduced from Part II, Section 4, Chapter 1, Appendix A.	
3	v	$v = V \div 3\,600$	0.1346 km/s	$v = V \div 3\,600$	0.07308 NM/s
4	R	$R = 943.27 \div V$, or $3^\circ/\text{s}$, whichever is less	$1.95^\circ/\text{s}$	$R = 509.26 \div V$, or $3^\circ/\text{s}$, whichever is less	$1.94^\circ/\text{s}$
5	r	$r = V \div 62.83 R$	3.96 km	$r = V \div 62.83 R$	2.16 NM
6	h	in thousands of metres	3.05	in thousands of feet	10
7	w	$w = 12h + 87$	123.6 km/h	$w = 2h + 47$	67 kt
8	w'	$w' = w \div 3\,600$	0.03433 km/s	$w' = w \div 3\,600$	0.0186 NM/s
9	E ₄₅	$E_{45} = 45w' \div R$	0.792 km	$E_{45} = 45w' \div R$	0.431 NM
10	t	$t = 60T$	60 s	$t = 60T$	60 s
11	L	$L = v t$	8.08 km	$L = v t$	4.38 NM
12	ab	$ab = 5v$	0.67 km	$ab = 5v$	0.37 NM
13	ac	$ac = 11v$	1.48 km	$ac = 11v$	0.80 NM
14	g _{i1} = g _{i3}	$g_{i1} = g_{i3} = (t - 5)v$	7.40 km	$g_{i1} = g_{i3} = (t - 5)v$	4.02 NM
15	g _{i2} = g _{i4}	$g_{i2} = g_{i4} = (t + 21)v$	10.90 km	$g_{i2} = g_{i4} = (t + 21)v$	5.92 NM
16	W _b	$W_b = 5w'$	0.17 km	$W_b = 5w'$	0.09 NM
17	W _c	$W_c = 11w'$	0.38 km	$W_c = 11w'$	0.20 NM
18	W _d	$W_d = W_c + E_{45}$	1.17 km	$W_d = W_c + E_{45}$	0.64 NM
19	W _e	$W_e = W_c + 2E_{45}$	1.96 km	$W_e = W_c + 2E_{45}$	1.07 NM
20	W _f	$W_f = W_c + 3E_{45}$	2.75 km	$W_f = W_c + 3E_{45}$	1.50 NM
21	W _g	$W_g = W_c + 4E_{45}$	3.55 km	$W_g = W_c + 4E_{45}$	1.93 NM

Line	Parameter	CALCULATIONS USING SI UNITS		CALCULATIONS USING NON-SI UNITS	
		Formula	Value	Formula	Value
22	W_h	$W_h = W_b + 4E_{45}$	3.34 km	$W_h = W_b + 4E_{45}$	1.82 NM
23	W_o	$W_o = W_b + 5E_{45}$	4.13 km	$W_o = W_b + 5E_{45}$	2.25 NM
24	W_p	$W_p = W_b + 6E_{45}$	4.92 km	$W_p = W_b + 6E_{45}$	2.69 NM
25	$W_{i1} = W_{i3}$	$W_{i1} = W_{i3} = (t + 6)w' + 4E_{45}$	5.43 km	$W_{i1} = W_{i3} = (t + 6)w' + 4E_{45}$	2.96 NM
26	$W_{i2} = W_{i4}$	$W_{i2} = W_{i4} = W_{i1} + 14w'$	5.91 km	$W_{i2} = W_{i4} = W_{i1} + 14w'$	3.22 NM
27	W_j	$W_j = W_{i2} + E_{45}$	6.71 km	$W_j = W_{i2} + E_{45}$	3.65 NM
28	$W_k = W_l$	$W_k = W_l = W_{i2} + 2E_{45}$	7.50 km	$W_k = W_l = W_{i2} + 2E_{45}$	4.08 NM
29	W_m	$W_m = W_{i2} + 3E_{45}$	8.29 km	$W_m = W_{i2} + 3E_{45}$	4.51 NM
30	W_{n3}	$W_{n3} = W_{i1} + 4E_{45}$	8.60 km	$W_{n3} = W_{i1} + 4E_{45}$	4.68 NM
31	W_{n4}	$W_{n4} = W_{i2} + 4E_{45}$	9.08 km	$W_{n4} = W_{i2} + 4E_{45}$	4.94 NM
32	XE	$XE = 2r + (t + 15)v + (t + 26 + 195 \div R)w'$	24.38 km	$XE = 2r + (t + 15)v + (t + 26 + 195 \div R)w'$	13.27 NM
33	YE	$YE = 11 v \cos 20^\circ + r(1 + \sin 20^\circ) + (t + 15)v \tan 5^\circ + (t + 26 + 125 \div R)w'$	12.73 km	$YE = 11 v \cos 20^\circ + r(1 + \sin 20^\circ) + (t + 15)v \tan 5^\circ + (t + 26 + 125 \div R)w'$	6.93 NM

Table I-4-3-App C-5. Rectangle equations

WARNING: This table is based on a range of TAS values from 165 to 540 km/h (90 to 290 kt), wind speeds up to 120 km/h (65 kt), and for nominal outbound timing between 1 and 3 minutes. This table should not be used outside these ranges.

	<i>SI UNITS</i> (distances in km; speeds in km/h; time in minutes)	<i>NON-SI UNITS</i> (distances in NM; speeds in kt; time in minutes)
<i>a) equations for 45/180 procedure turn</i>		
x_{\max}	$TAS(0.0165t + 0.0431) + W(0.0165t + 0.0278) + 3.4$	$TAS(0.0165t + 0.0431) + W(0.0165t + 0.0278) + 1.8$
y_{\max}	$TAS(0.002t + 0.022) + W(0.002t + 0.0333) - 0.74$	$TAS(0.002t + 0.022) + W(0.002t + 0.0333) - 0.4$
y_{\min}	$TAS(-0.002t - 0.0137) + W(0.002t - 0.0594) + 1.67$	$TAS(-0.002t - 0.0137) + W(-0.002t - 0.0594) + 0.9$
<i>b) equations for 80/260 procedure turn</i>		
x_{\max}	$TAS(0.0165t + 0.0421) + W(0.0165t + 0.0489) - 3.34$	$TAS(0.0165t + 0.0421) + W(0.0165t + 0.0489) - 1.8$
y_{\max}	$TAS(0.002t + 0.0263) + W(0.002t + 0.0322) - 1.85$	$TAS(0.002t + 0.0263) + W(0.002t + 0.0322) - 1.0$
y_{\min}	$TAS(-0.002t - 0.01) + W(0.002t - 0.0591) + 1.3$	$TAS(-0.002t - 0.01) + W(-0.002t - 0.0591) + 0.7$
<i>c) equations for base turn</i>		
x_{\max}	$TAS(0.0173t + 0.0181) + W(0.0166t + 0.0209) - 0.93$	$TAS(0.0173t + 0.0181) + W(0.0166t + 0.0209) - 0.5$
y_{\max}	$TAS(-0.0004t + 0.0373) + W(-0.0072t + 0.0404) + 0.164t - 3.15$	$TAS(-0.0004t + 0.0373) + W(-0.0072t + 0.0404) + 0.0887t - 1.7$
y_{\min}	$TAS(-0.0122) + W(0.0151t - 0.0639) - 0.1845t + 1.48$	$TAS(-0.0122) + W(0.0151t - 0.0639) - 0.0996t + 0.8$
<i>d) equations for racetrack</i>		
x_{\max}	$TAS(0.0167t + 0.0297) + W(0.0167t + 0.0381) - 1.67$	$TAS(0.0167t + 0.0297) + W(0.0167t + 0.0381) - 0.9$
x_{\min}	$TAS(-0.0241) + W(-0.037) + 2.04$	$TAS(-0.0241) + W(-0.037) + 1.1$
y_{\max}	$TAS(0.0012t + 0.0266) + W(0.0158t + 0.0368) + 0.843t - 5.37$	$TAS(0.0012t + 0.0266) + W(0.0158t + 0.0368) + 0.455t - 2.9$
y_{\min}	$TAS(-0.0015t - 0.0202) + W(-0.0167t - 0.027) + 1.3$	$TAS(-0.0015t - 0.0202) + W(-0.0167t - 0.027) + 0.7$

EXAMPLE (SI UNITS)

Specification: 2 min base turn for 260 km/h IAS, altitude 1 850 m, ICAO wind, VOR facility with a cone of ambiguity of 50°:

$$TAS = 260 \times 1.1243 = 292 \text{ km/h}$$

$$W = 12 \times 1.85 + 87 = 109 \text{ km/h}$$

$$\text{Fix error} = 1.85 \times \tan 50 = 2.20 \text{ km}$$

Calculation (equations from c) above):

$$x_{\max} = 292(0.0173 \times 2 + 0.0181) + 109(0.0166 \times 2 + 0.0209) - 0.93 = 20.36 \text{ km/h}$$

$$y_{\max} = 292(-0.0004 \times 2 + 0.0373) + 109(-0.0072 \times 2 + 0.0404) + 0.164 \times 2 - 3.15 = 10.67 \text{ km/h}$$

$$y_{\min} = 292(-0.0122) + 109(0.0151 \times 2 - 0.0639) - 0.1845 \times 2 + 1.48 = -6.12 \text{ km}$$

Template plotting values (including addition for fix error of 2.20 km):

$$x_{\max} = 22.6 \text{ km}$$

$$y_{\max} = 12.9 \text{ km}$$

$$y_{\min} = -8.3 \text{ km}$$

EXAMPLE (NON-SI UNITS):

Specification: 1 min 45/180 procedure turn for 140 kt IAS, altitude 6 000 ft, ICAO wind, NDB facility.

TAS = $140 \times 1.1231 = 157$ kt

W = $2 \times 6 + 47 = 59$ kt

Fix error = $0.164 \times 6 \tan 40 = 0.83$ NM

Calculation (equations from a) above):

$x_{\max} = 157(0.0165 \times 1 + 0.0431) + 59(0.0165 \times 1 + 0.0278) + 1.8 = 13.77$ NM

$y_{\max} = 157(0.002 \times 1 + 0.022) + 59(0.002 \times 1 + 0.0333) - 0.4 = 5.45$ NM

$y_{\min} = 157(-0.002 \times 1 - 0.0137) + 59(-0.002 \times 1 - 0.0594) + 0.9 = -5.19$ NM

Template plotting values (including addition of fix error of 0.83 NM):

$x_{\max} = 14.6$ NM

$y_{\max} = 6.3$ NM

$y_{\min} = -6.0$ NM

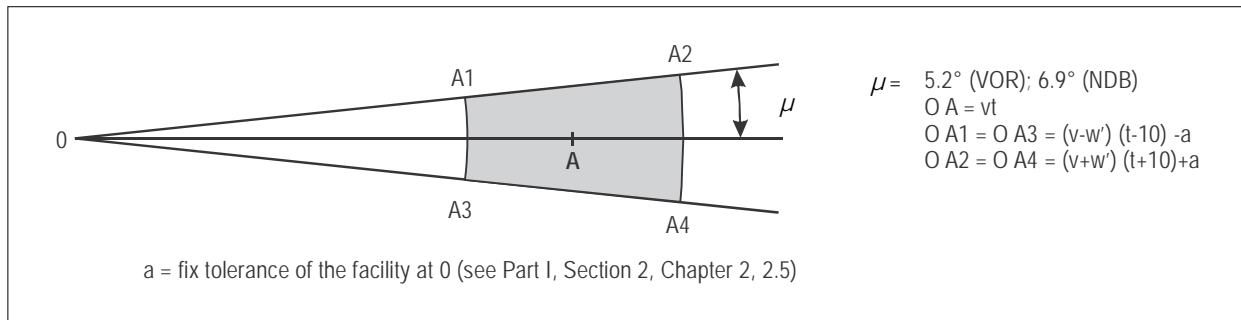

Figure I-4-3-App C-1. VOR or NDB at 0 — time from 0 to A

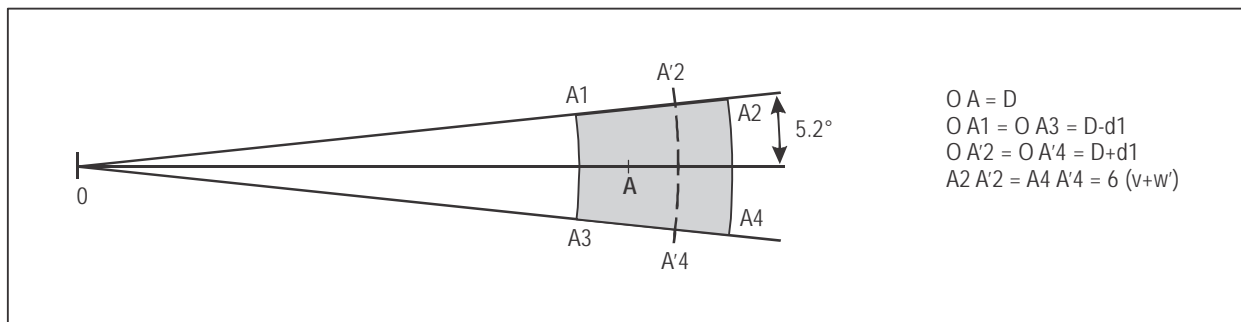

Figure I-4-3-App C-2. VOR/DME at 0

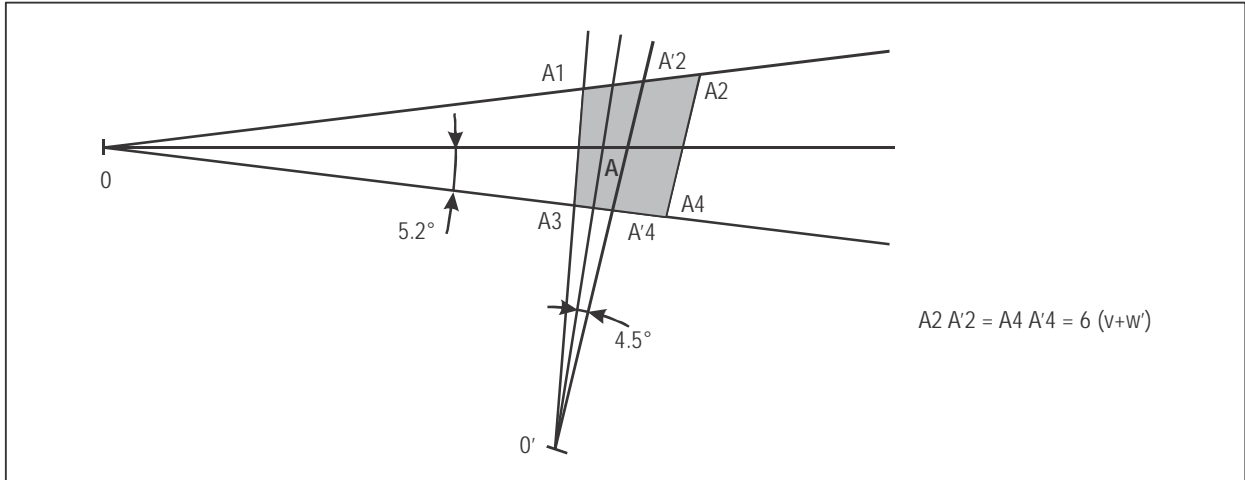

Figure I-4-3-App C-3. VOR at 0 and VOR at 0'

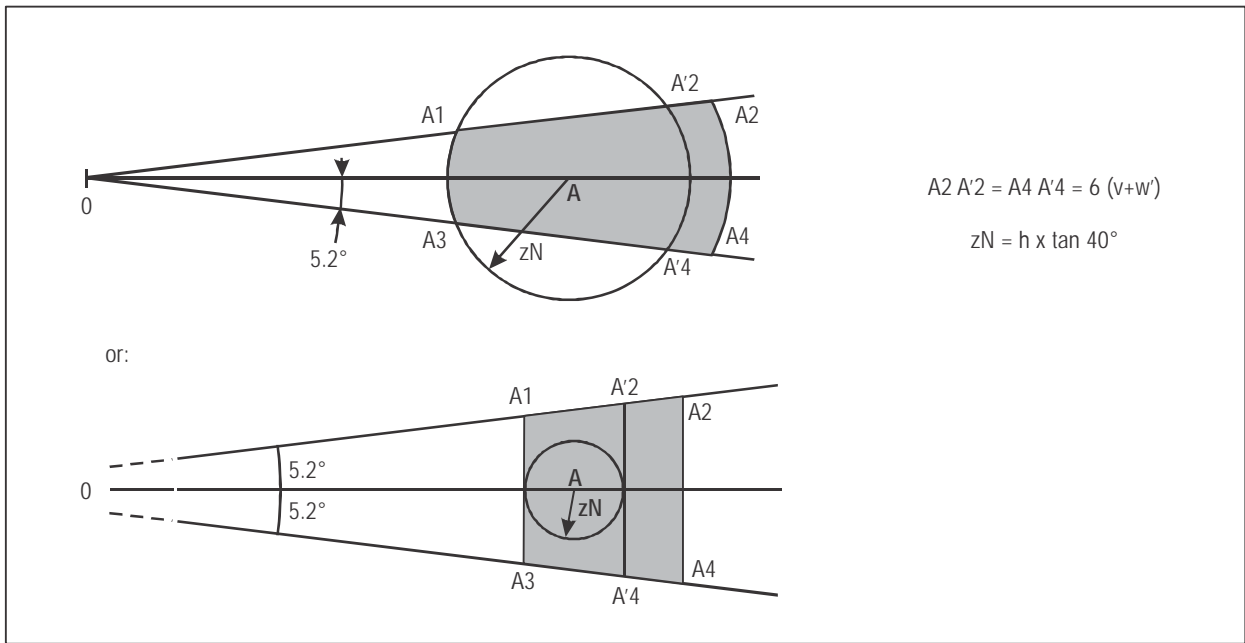

Figure I-4-3-App C-4. VOR at 0 and NDB or locator at A

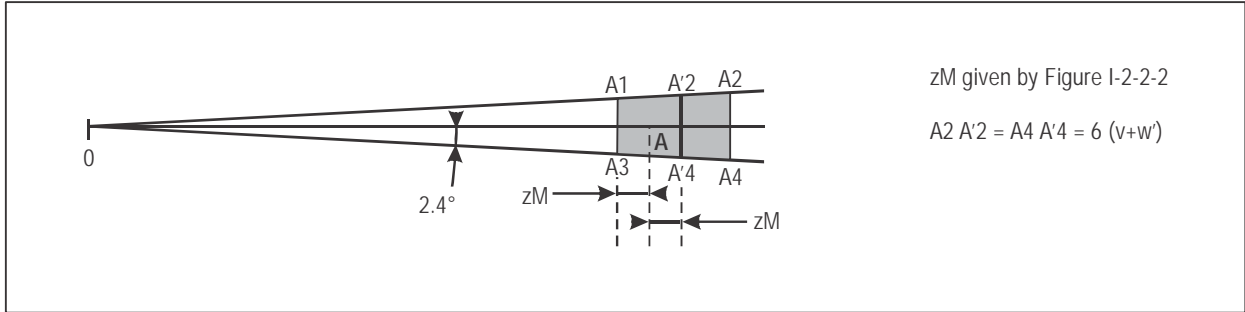

Figure I-4-3-App C-5. Localizer at 0 and marker at A

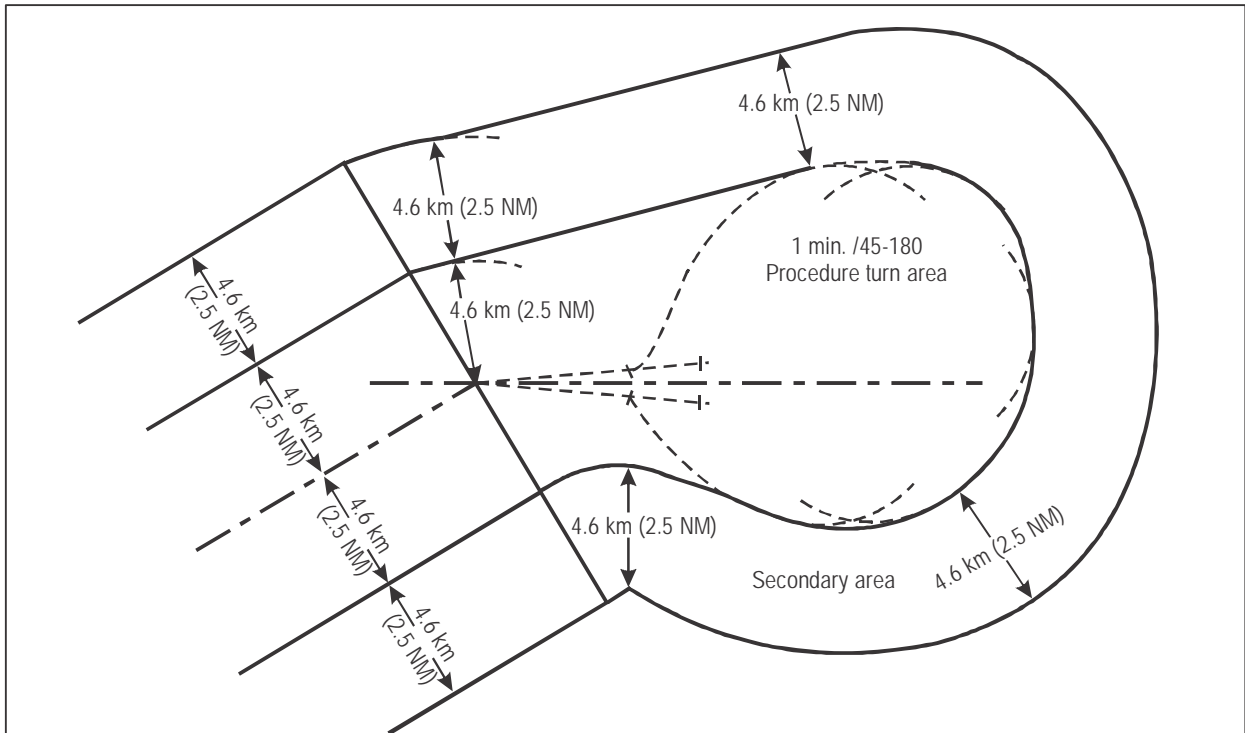

Figure I-4-3-App C-6. Interface between initial segment areas and procedure turn areas

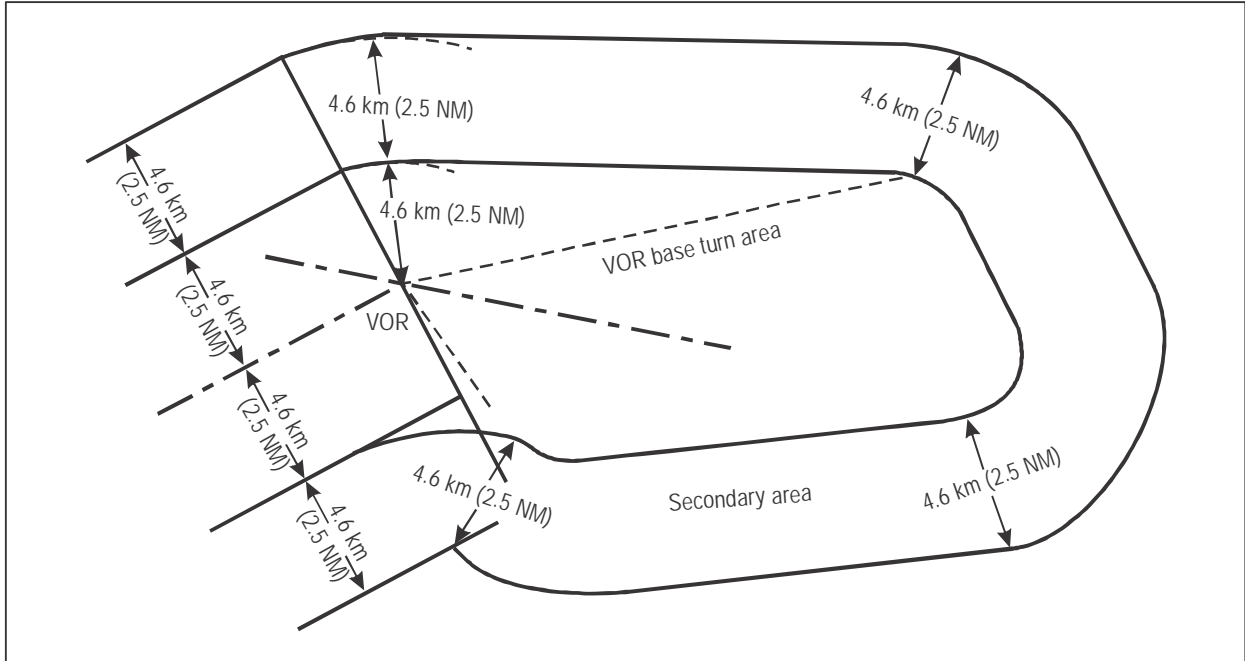

Figure I-4-3-App C-7. Interface between initial segment areas and base turn areas

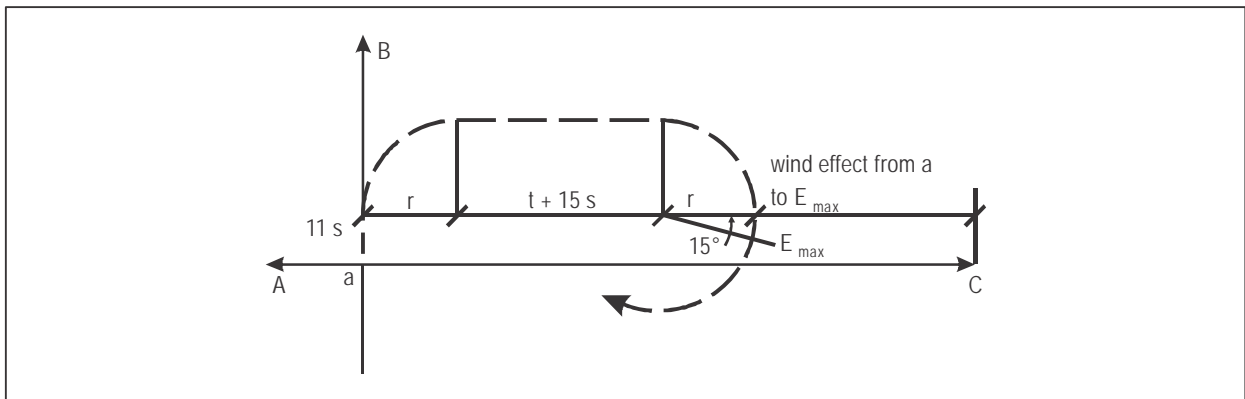

Figure I-4-3-App C-8.

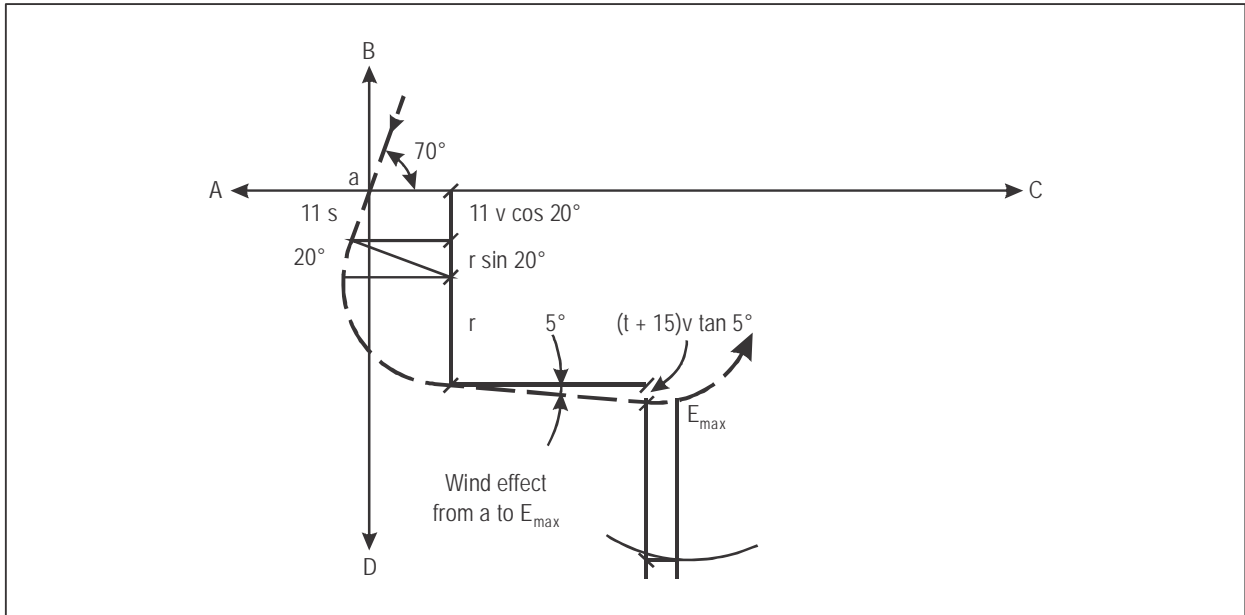

Figure I-4-3-App C-9.

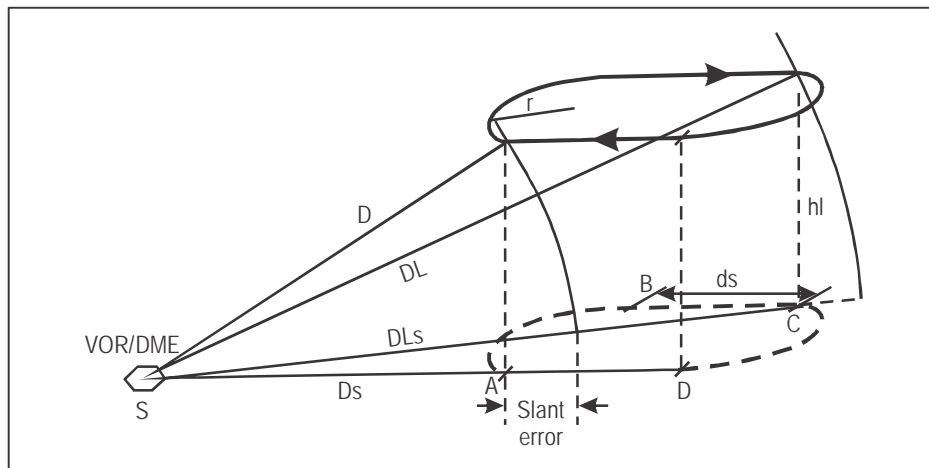

Figure I-4-3-App C-10.

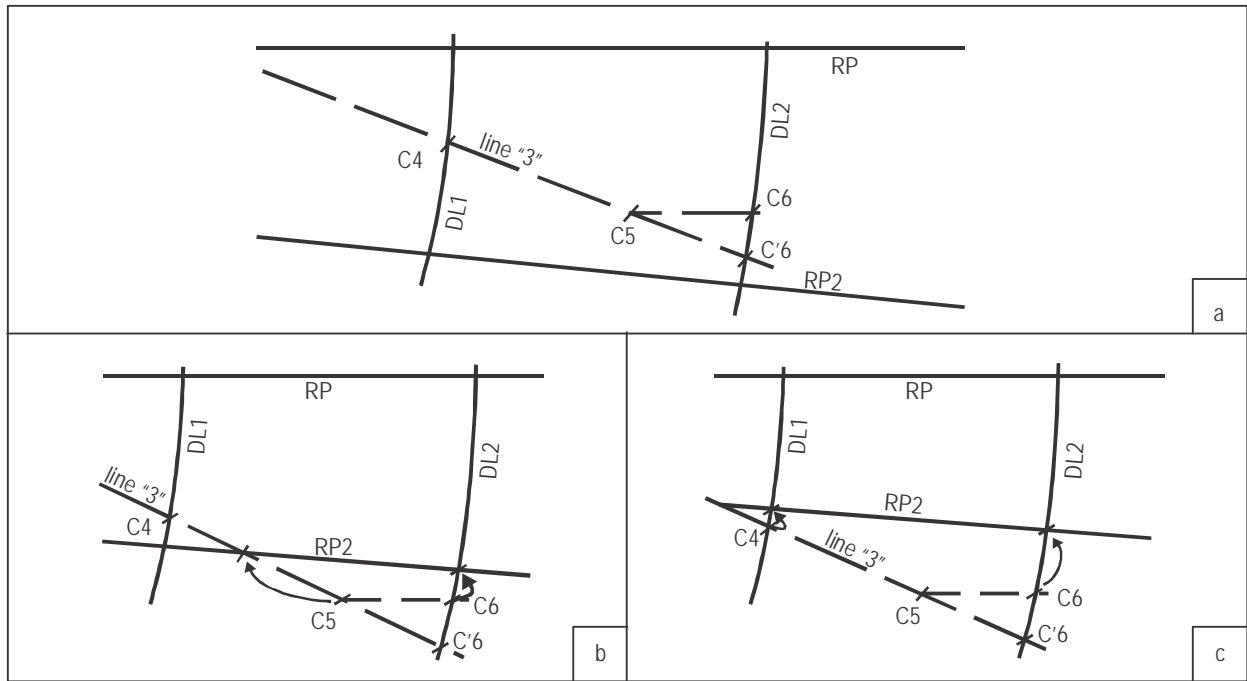

Figure I-4-3-App C-11.

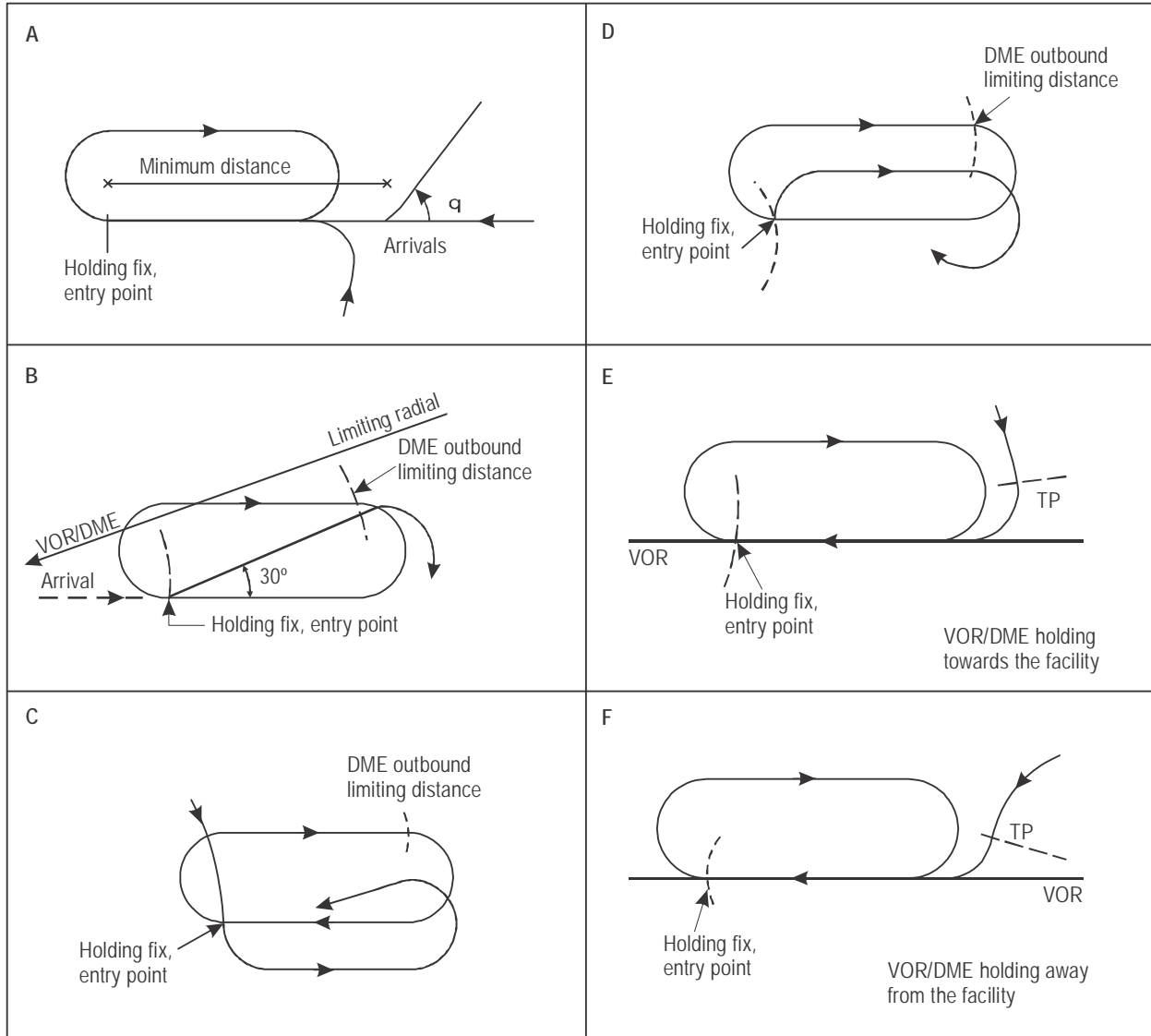

Figure I-4-3-App C-12.

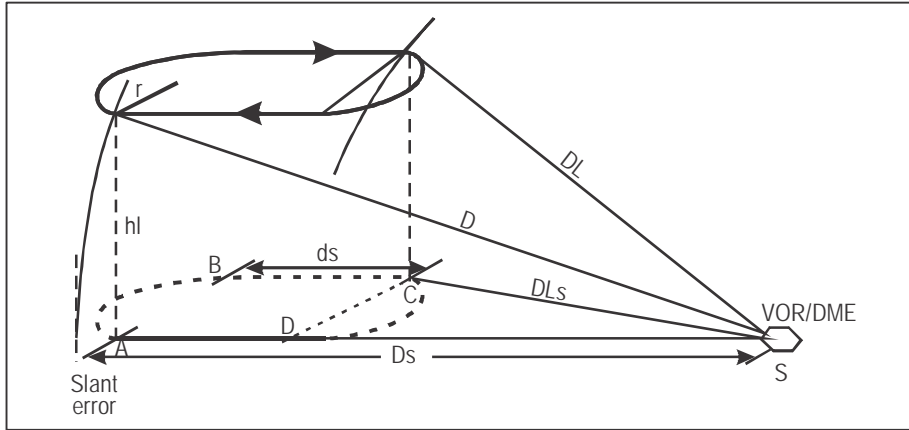

Figure I-4-3-App C-13.

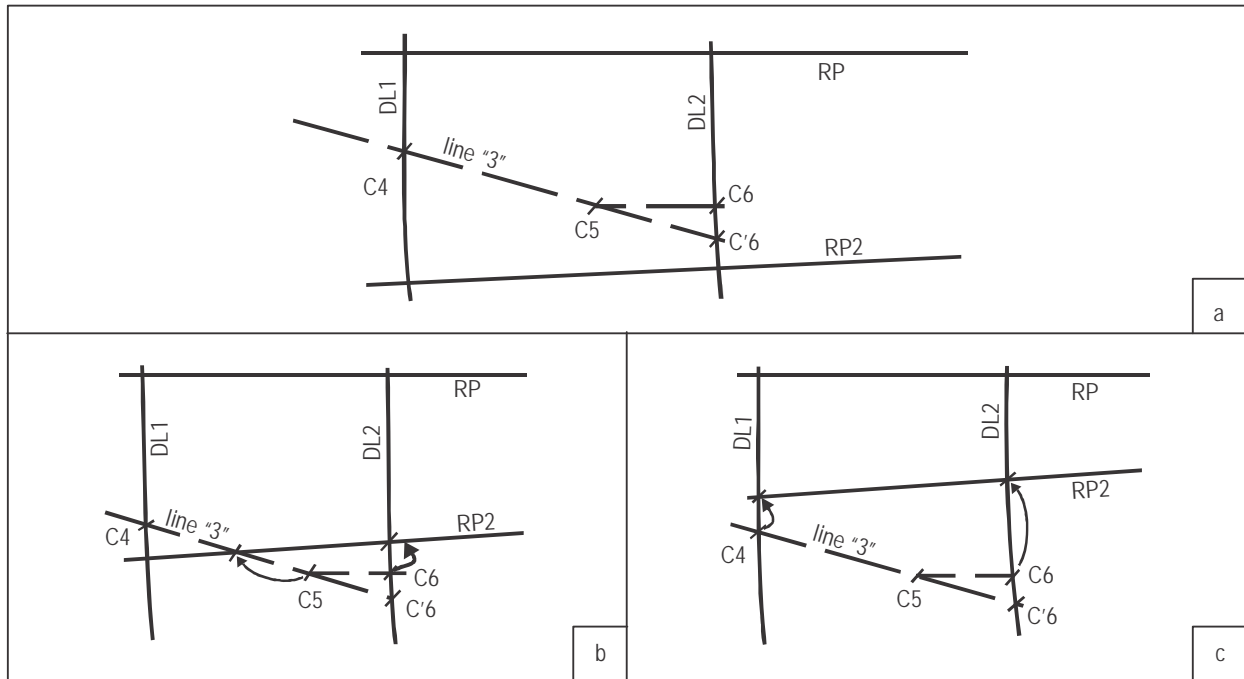

Figure I-4-3-App C-14.

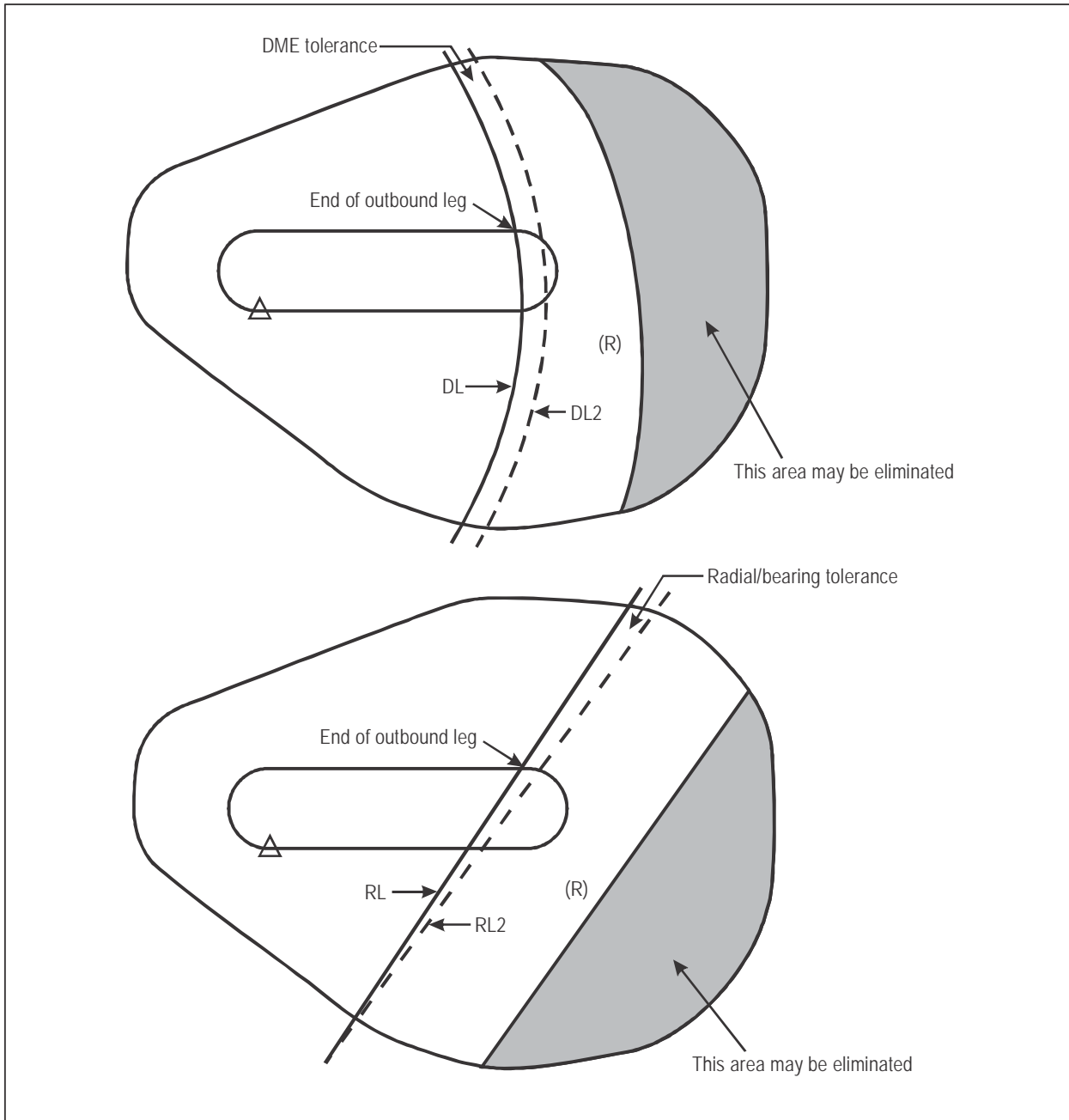

Figure I-4-3-App C-15. Example for area reduction using DME or intersecting radial or bearing

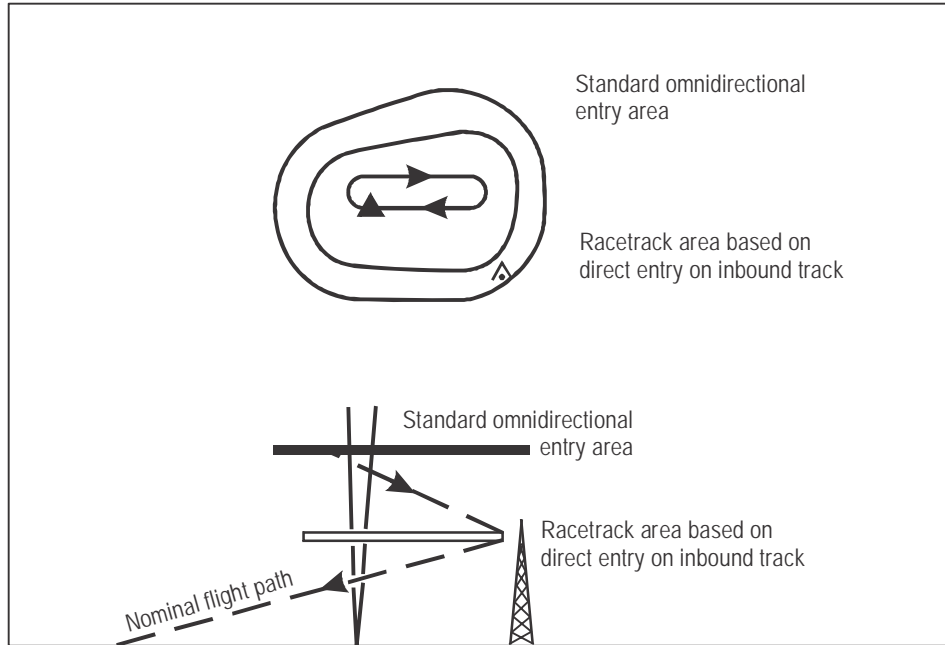

Figure I-4-3-App C-16. Example of racetrack entry via standard/omnidirectional entry at higher altitude (racetrack area reduced for “on axis” entry)

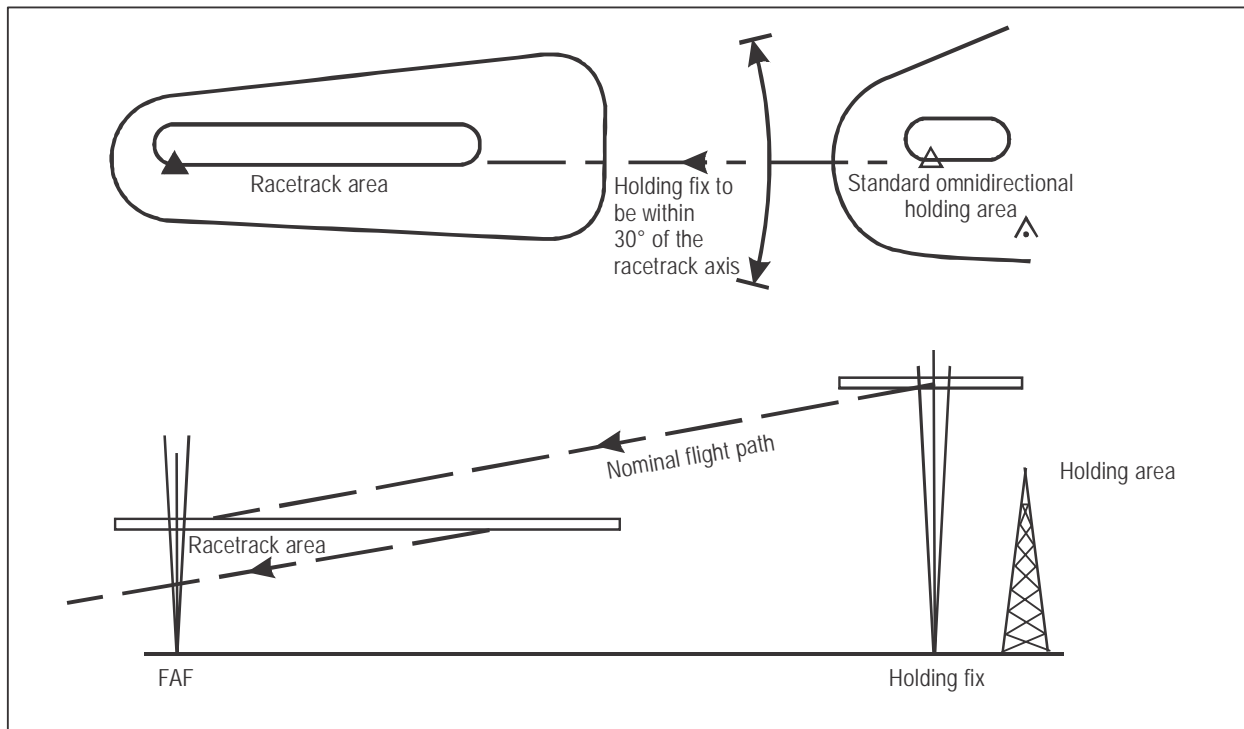

Figure I-4-3-App C-17. Example of restricted racetrack entry via restricted or specified track(s) (racetrack area reduced for “on axis” entry)

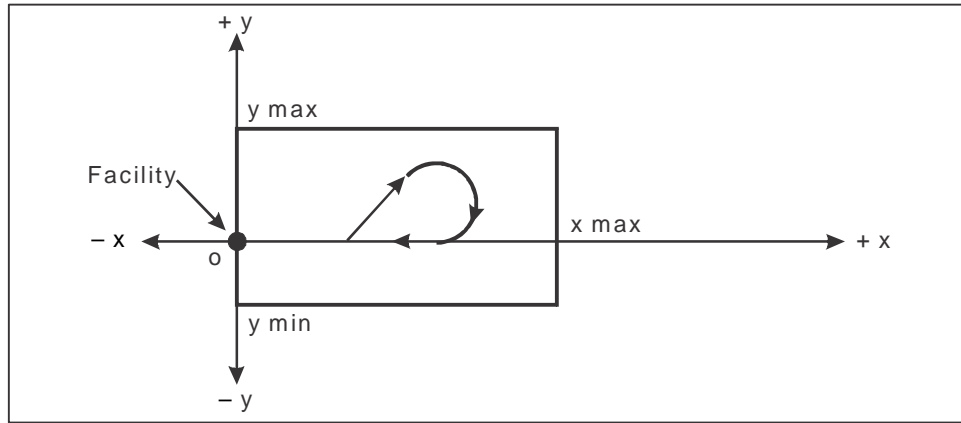

Figure I-4-3-App C-18. Construction of simplified area — example showing rectangle for procedure turn

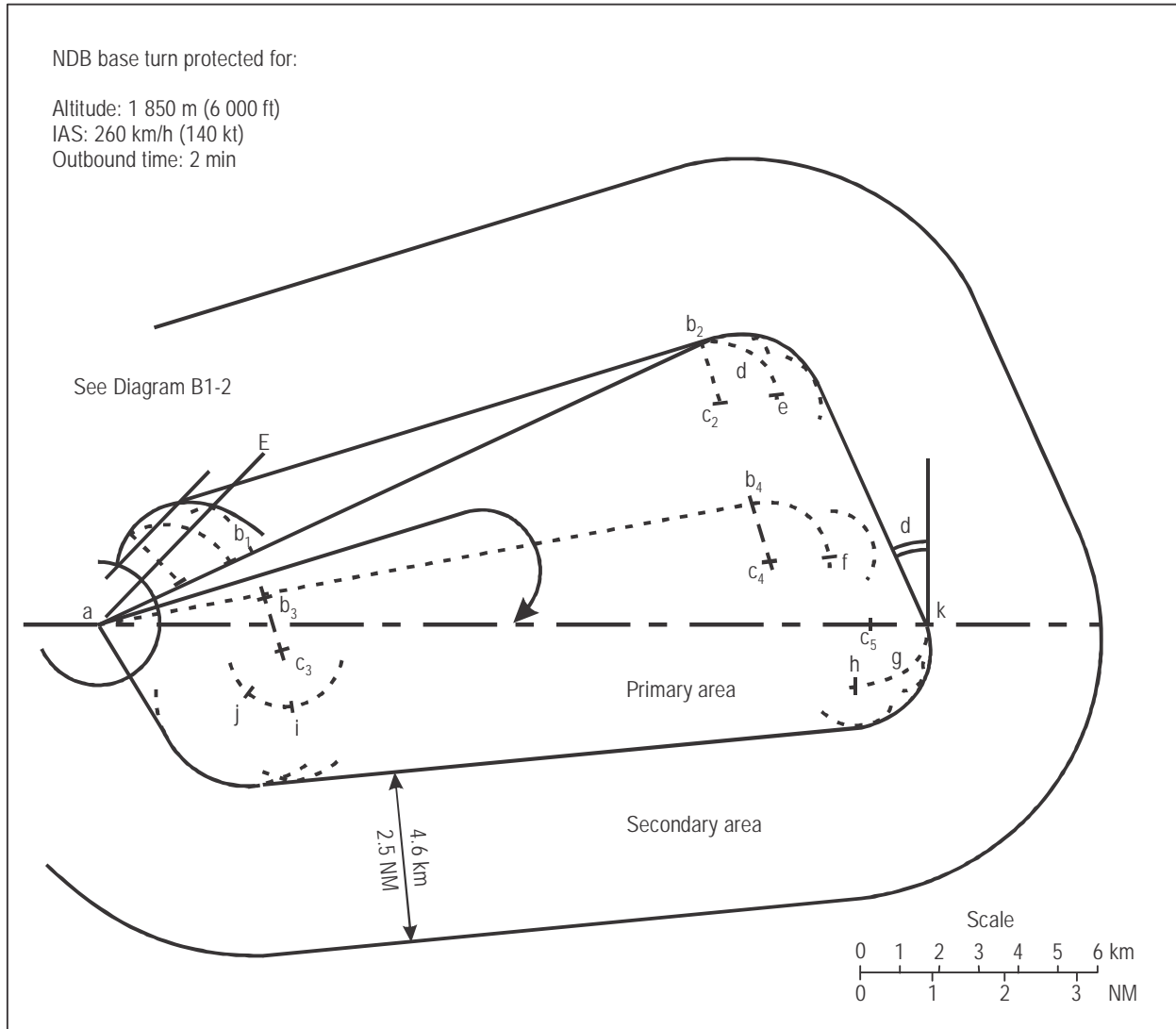

Diagram I-4-3-App C-1. NDB base turn area

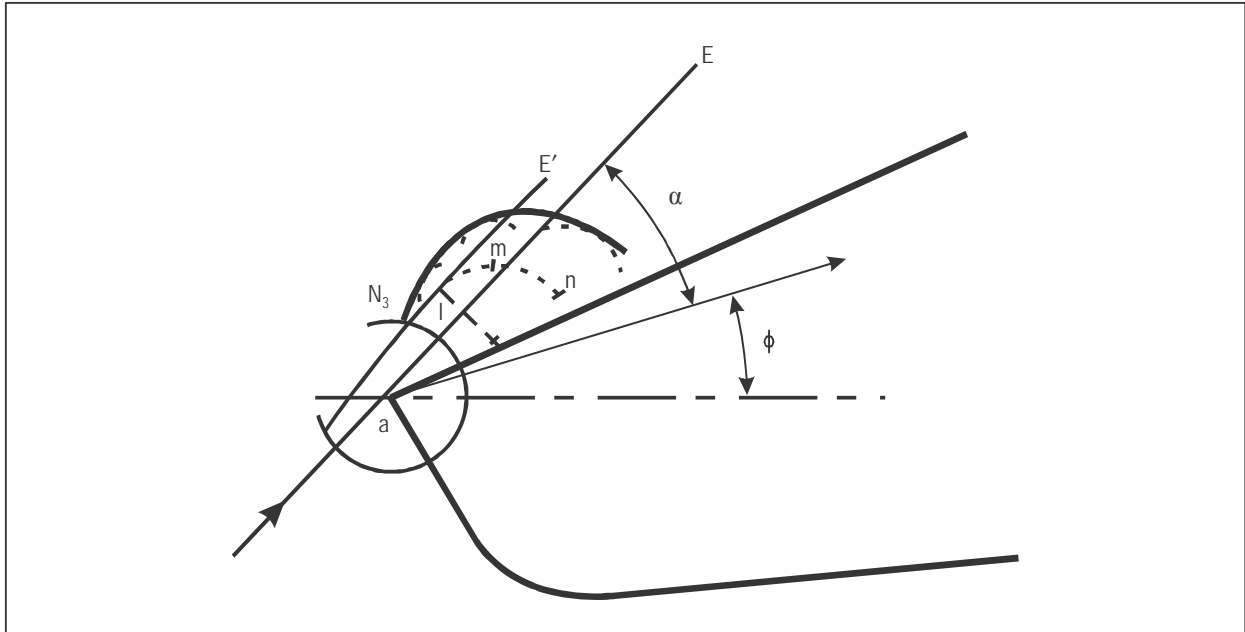

Diagram I-4-3-App C-2. Protection of the entry to a base turn

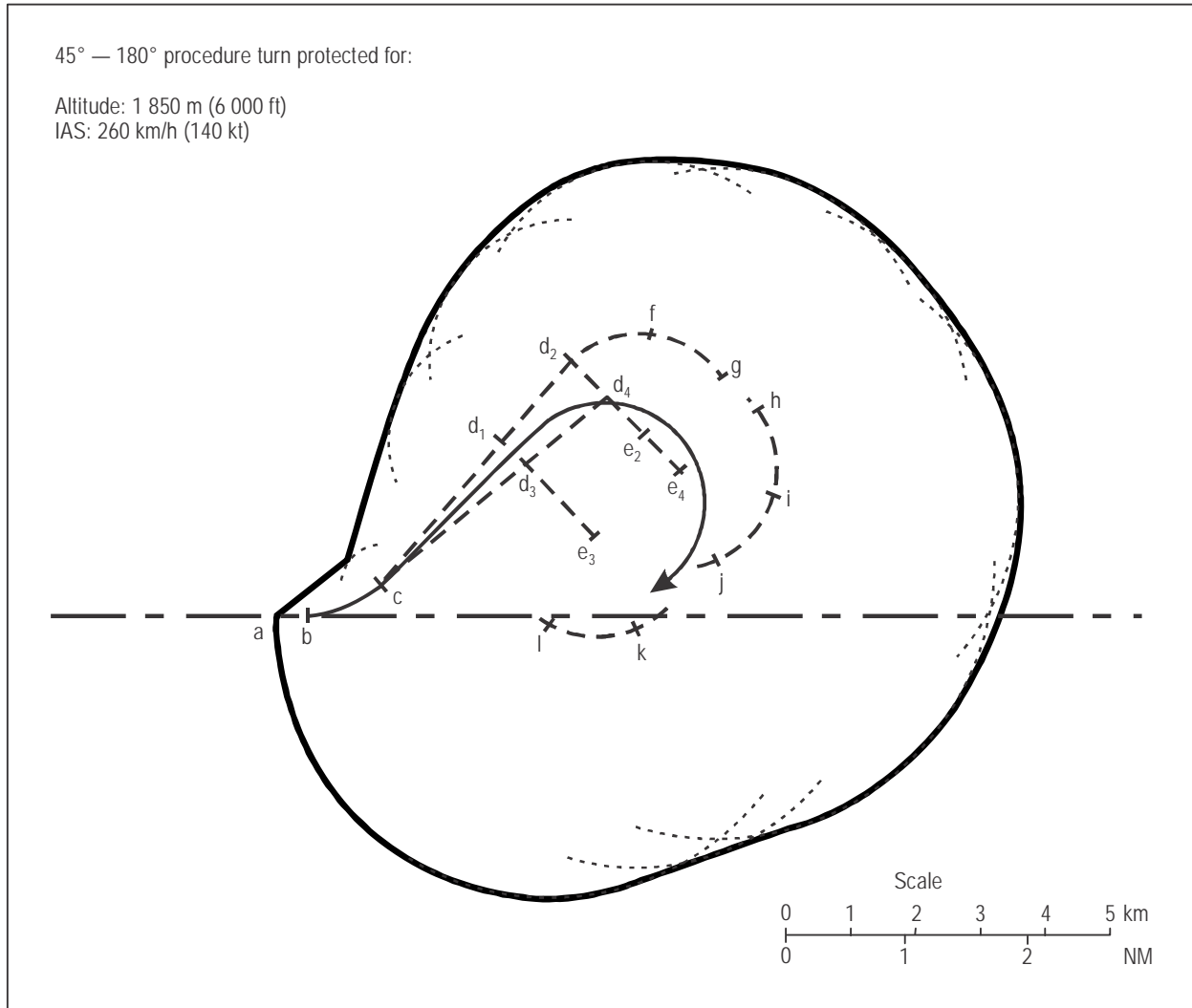

Diagram I-4-3-App C-3. 45° — 180° procedure turn template

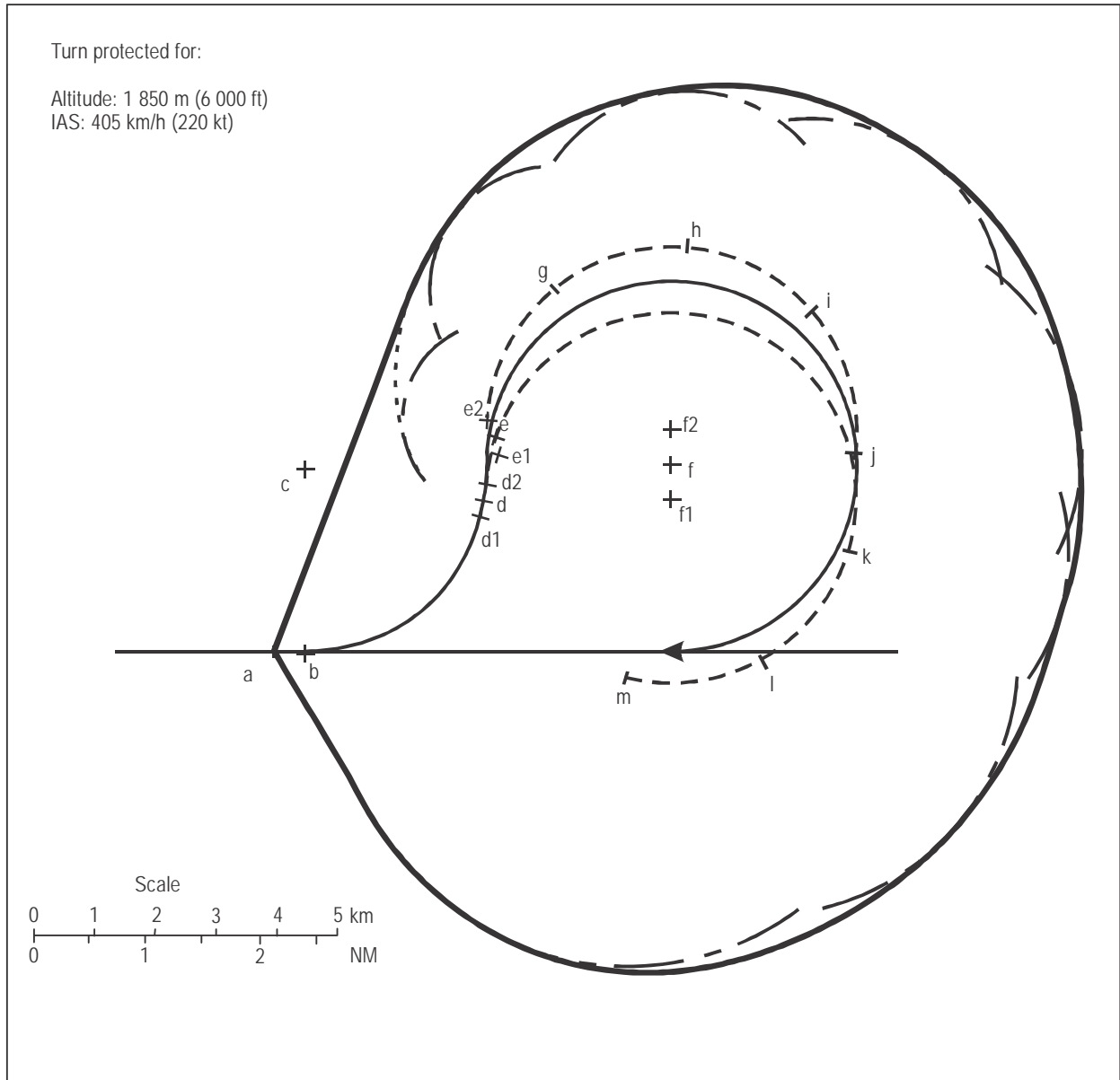

Diagram I-4-3-App C-4. 80° — 260° procedure turn template

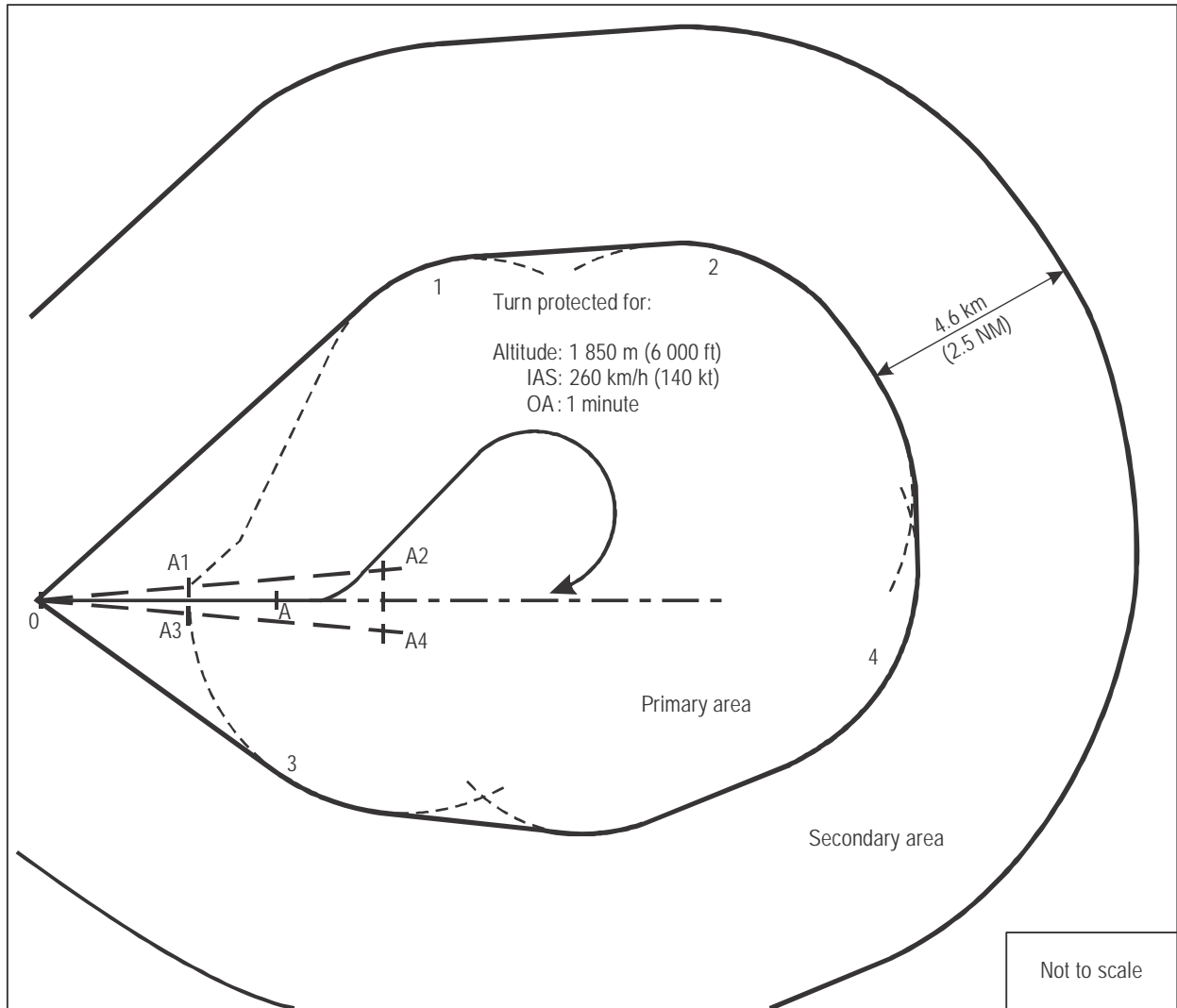

Diagram I-4-3-App C-5. VOR 45° — 180° procedure turn

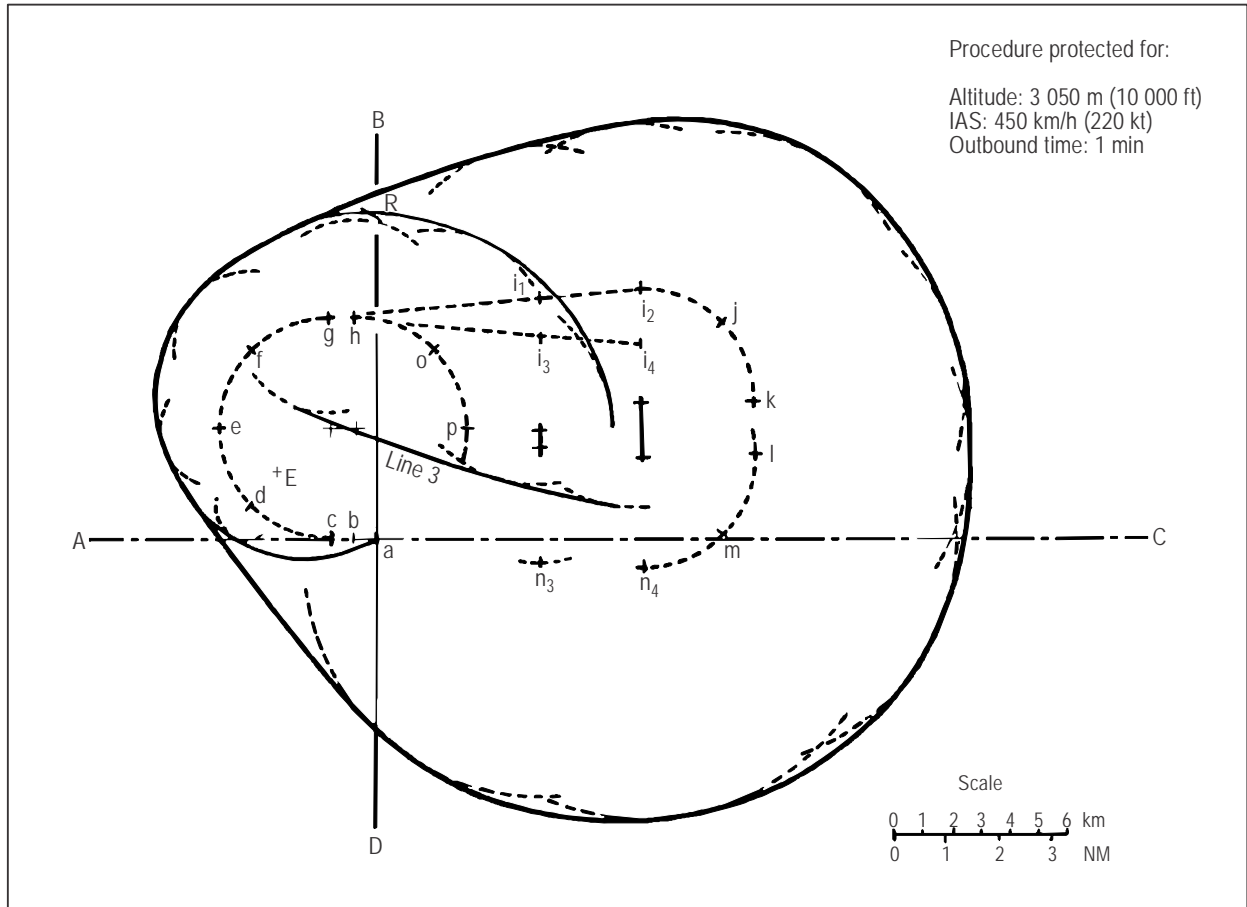

Diagram I-4-3-App C-6. Holding/racetack template with associated construction points

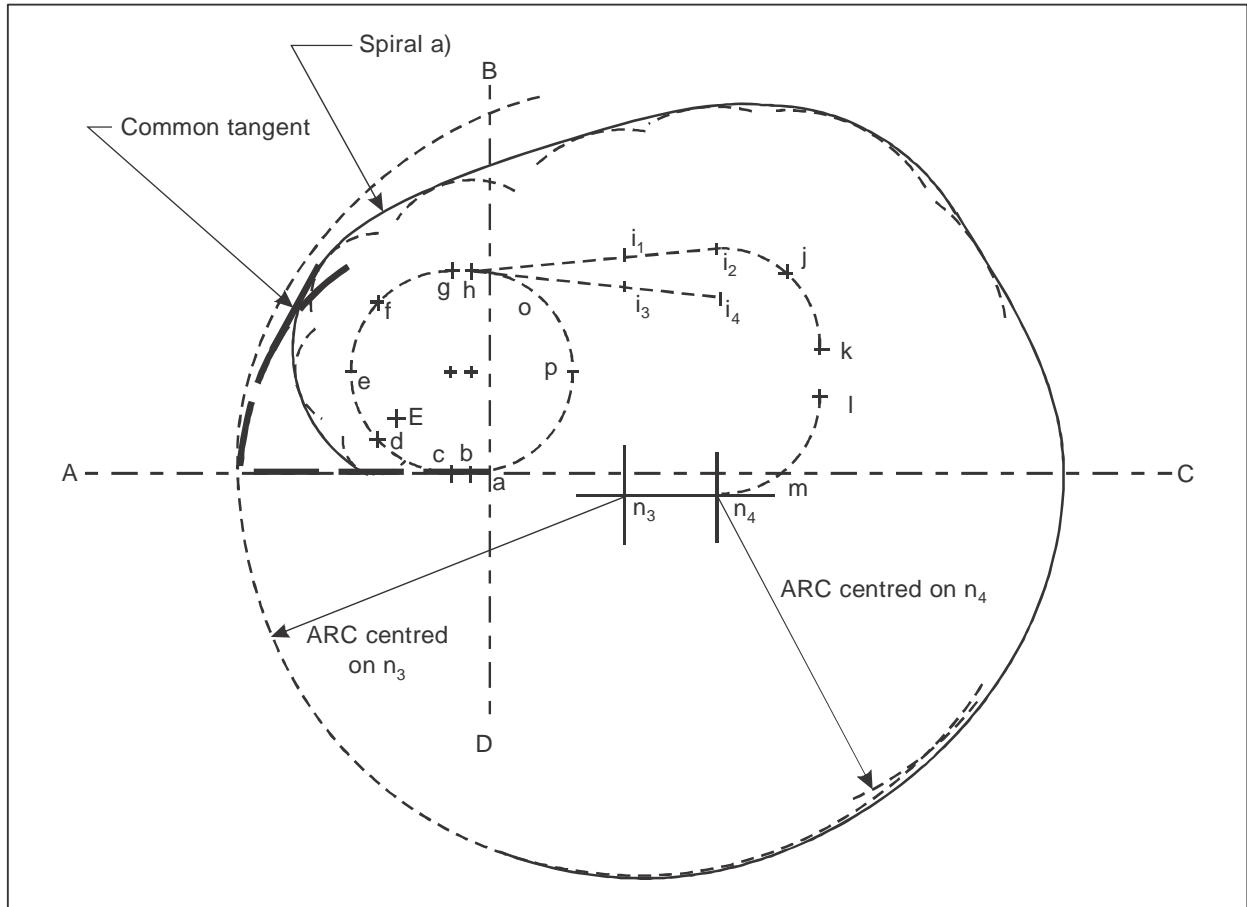

Diagram I-4-3-App C-6 a). Outline of template when arc centred on n3 does not intersect spiral a)

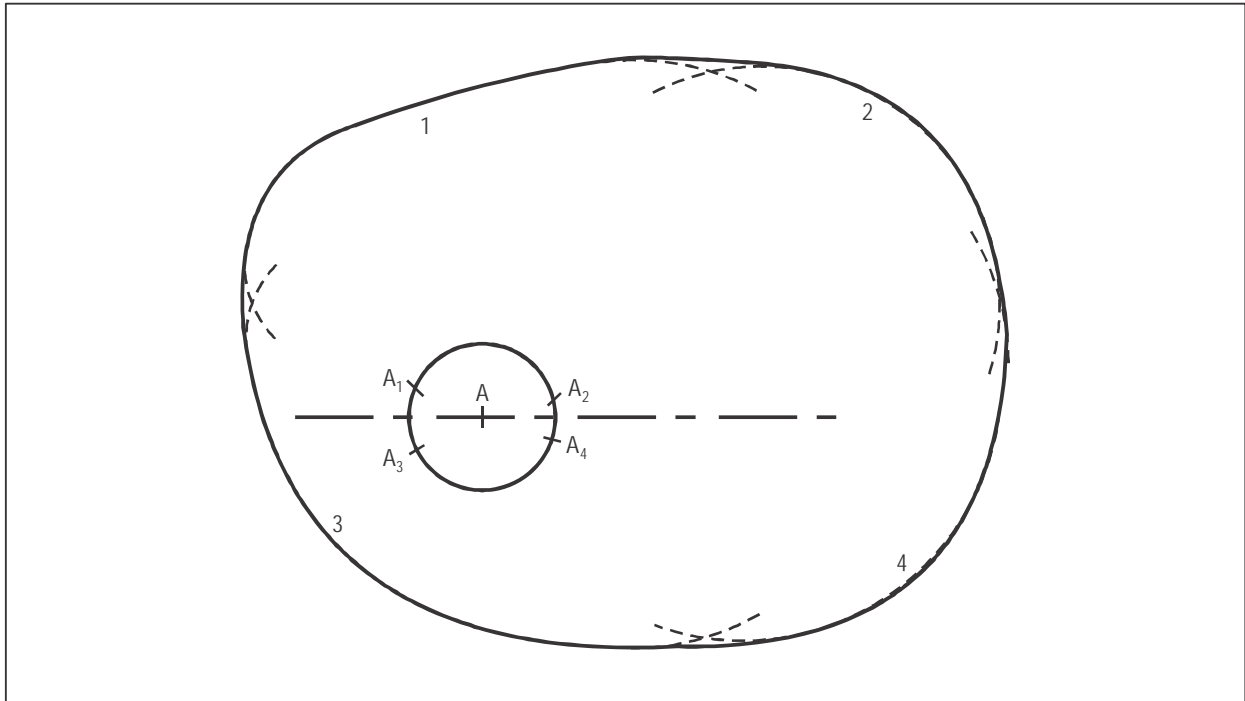

Diagram I-4-3-App C-7. Construction of the basic area

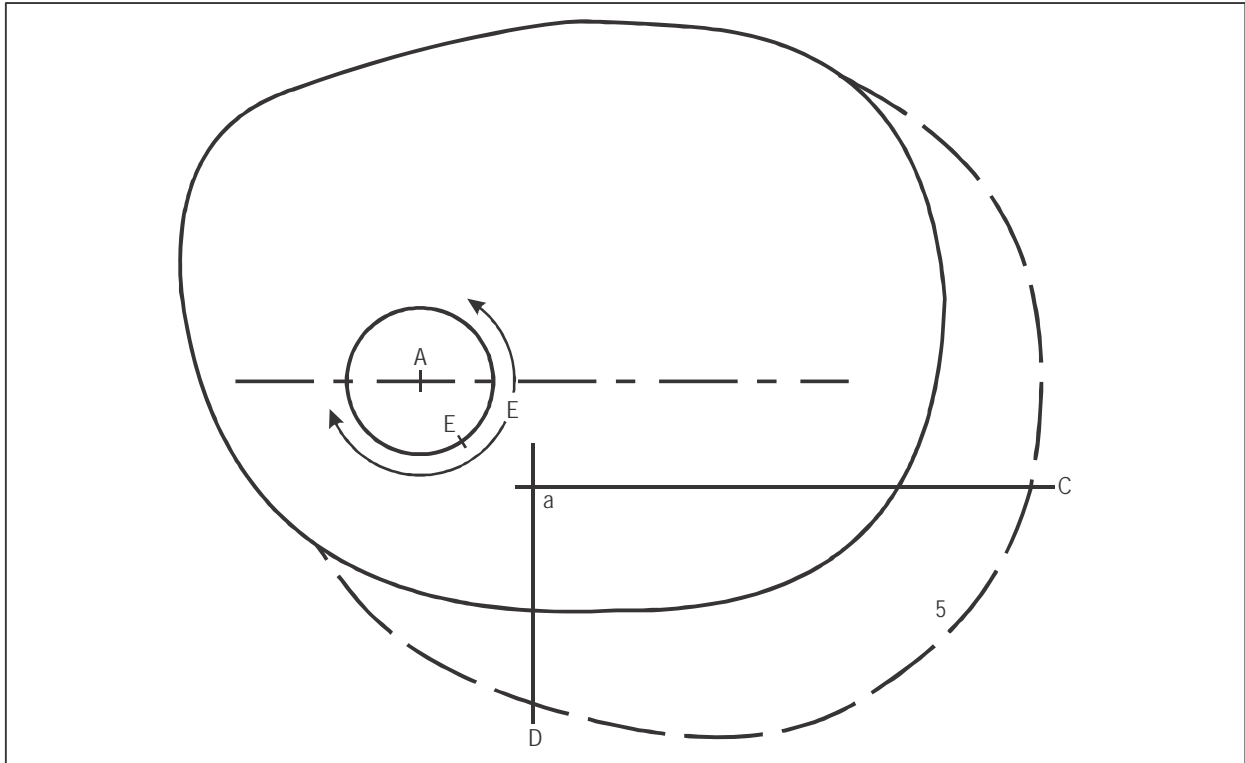

Diagram I-4-3-App C-8. Construction of the entry area; use of point E, the axis of the template being parallel to the procedure axis

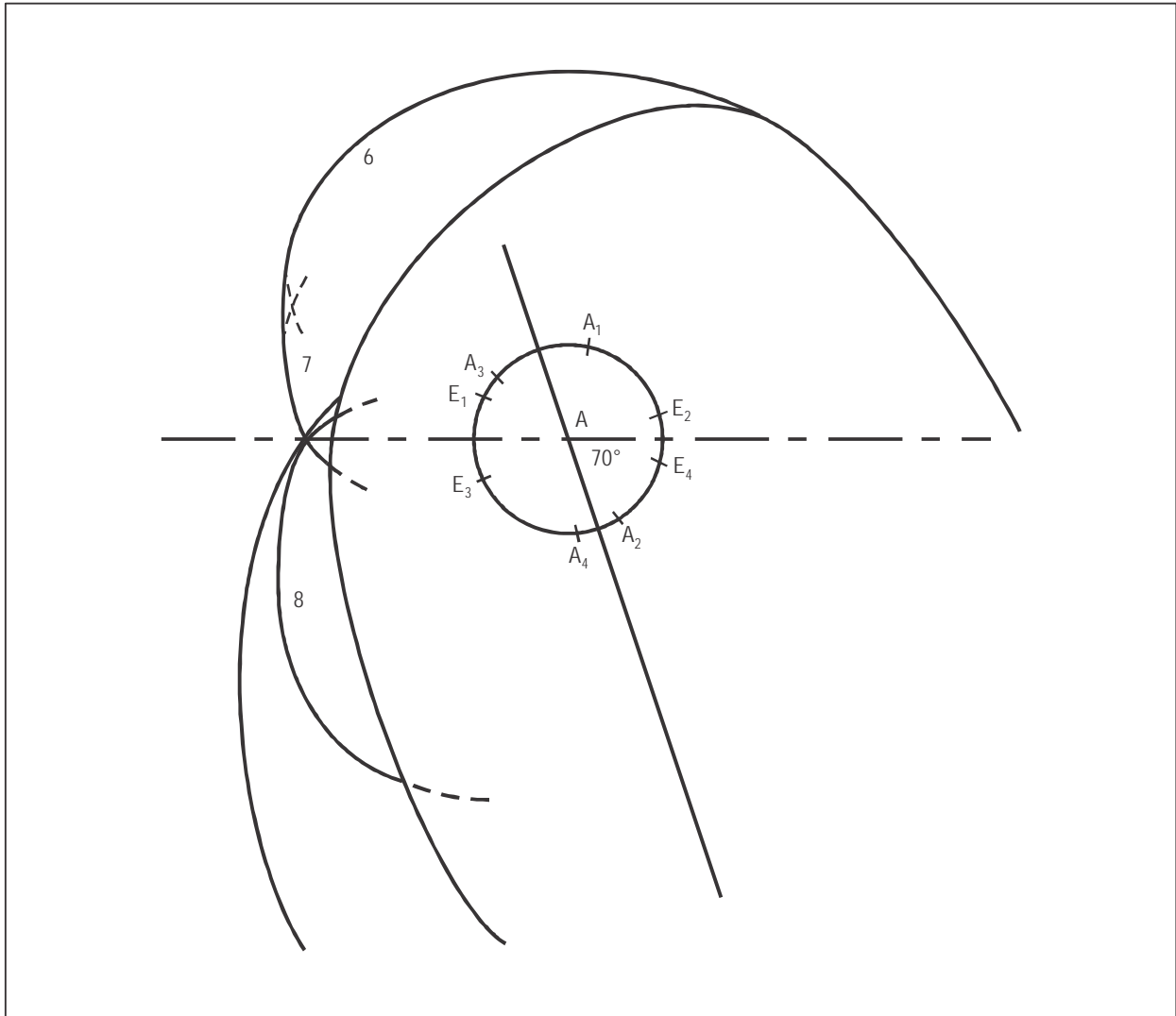

Diagram I-4-3-App C-9. Construction of the entry area; the axis of the template making an angle of 70° with the procedure axis

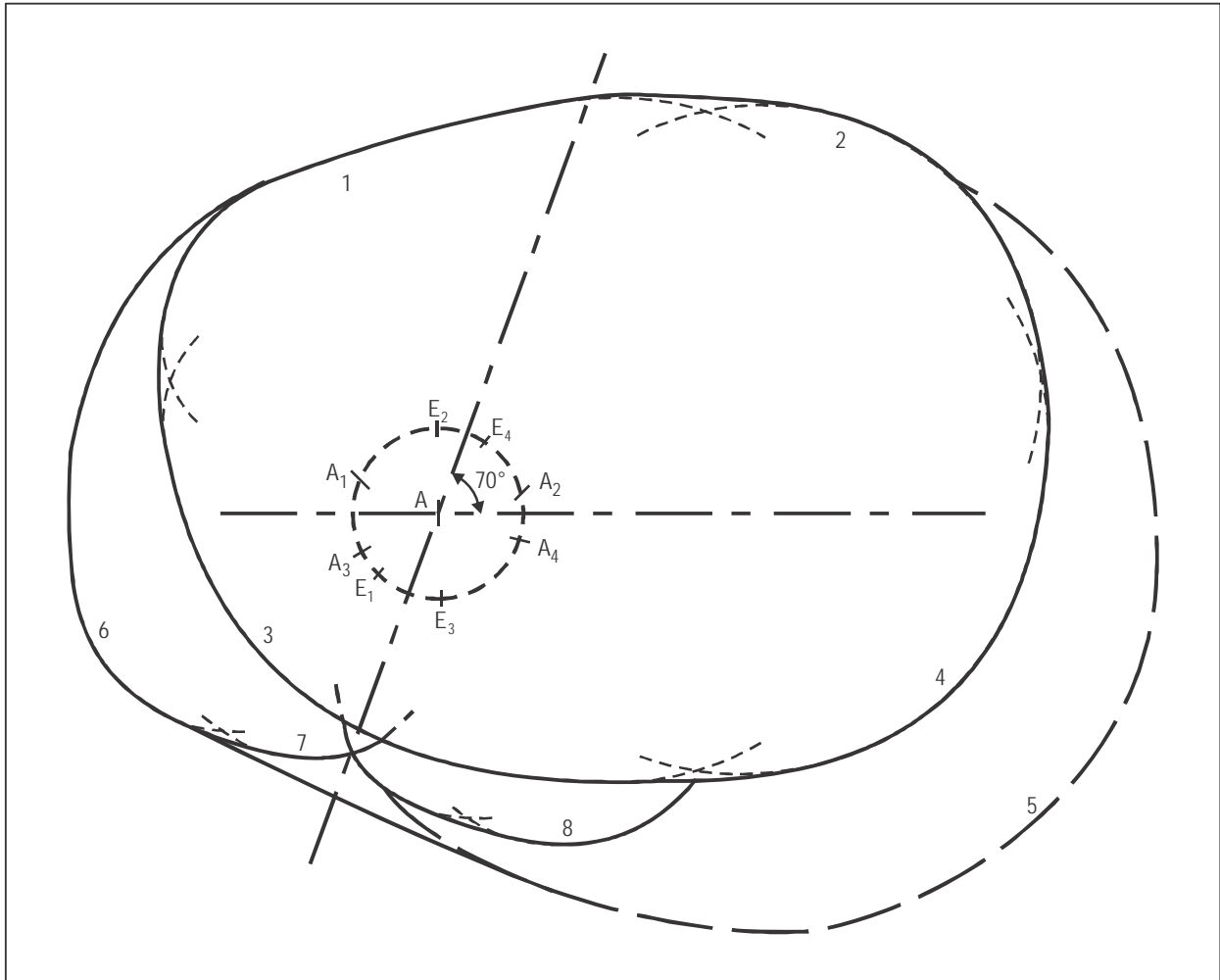

Diagram I-4-3-App C-10. Basic area with omnidirectional entry areas; procedure overhead a facility

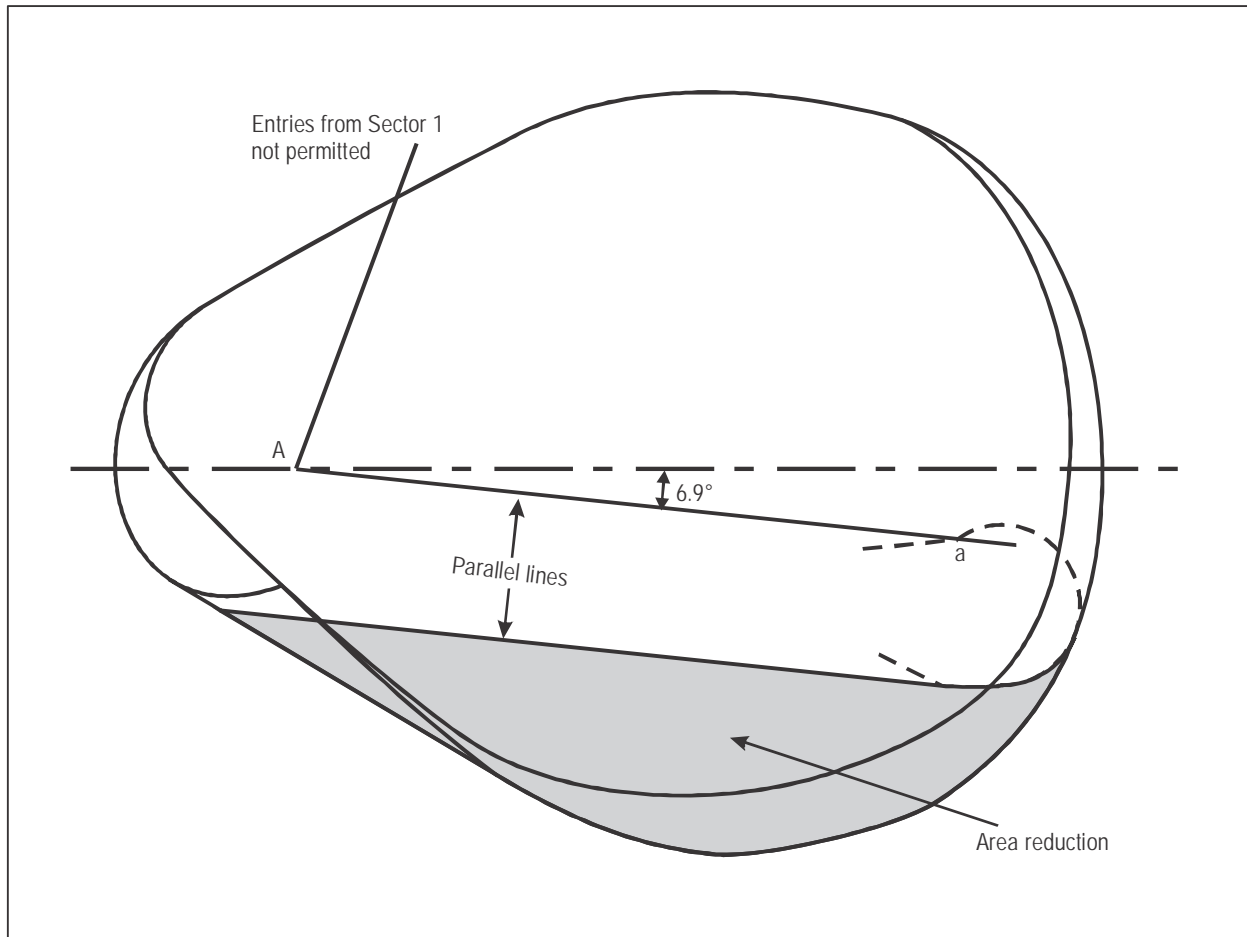

Diagram I-4-3-App C-11. Area reduction for a procedure overhead an NDB when entries from Sector 1 are not permitted

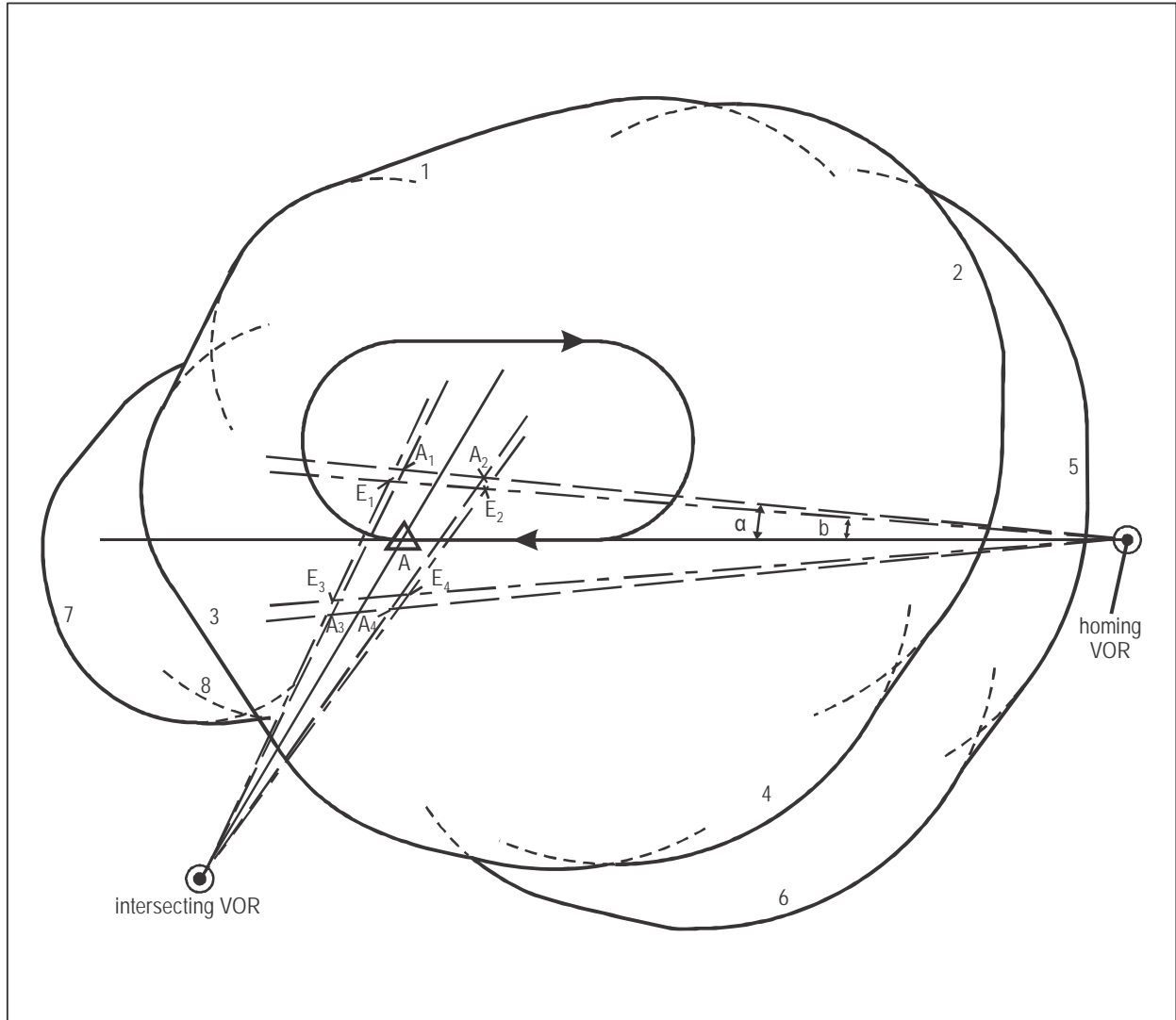

Diagram I-4-3-App C-12. Procedure at the intersection of VOR radials — Basic area and the associated entry area assuming entries along the procedure track and intersecting radial

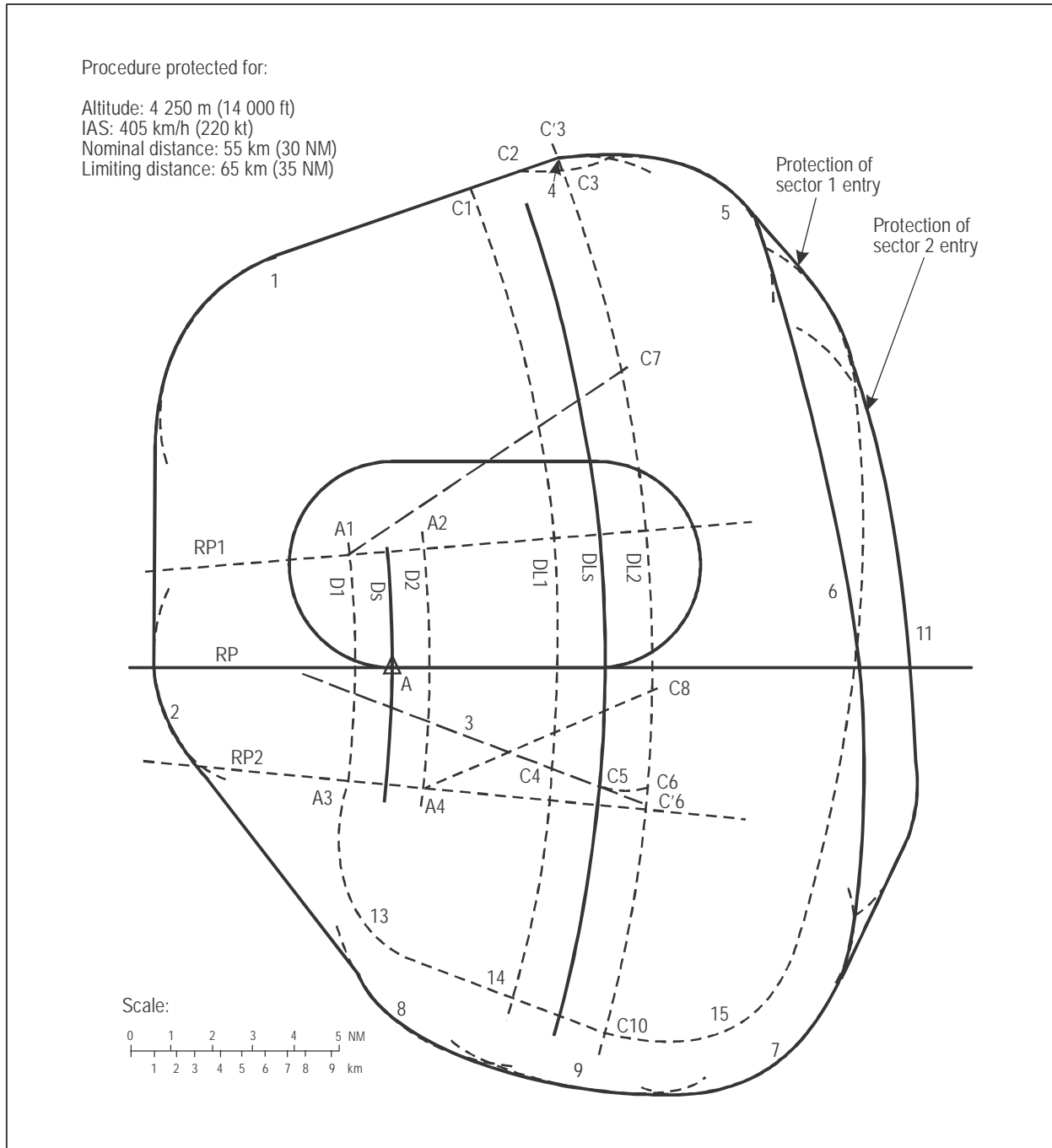

Diagram I-4-3-App C-13. VOR/DME procedure towards the facility — basic area and associated area for entries

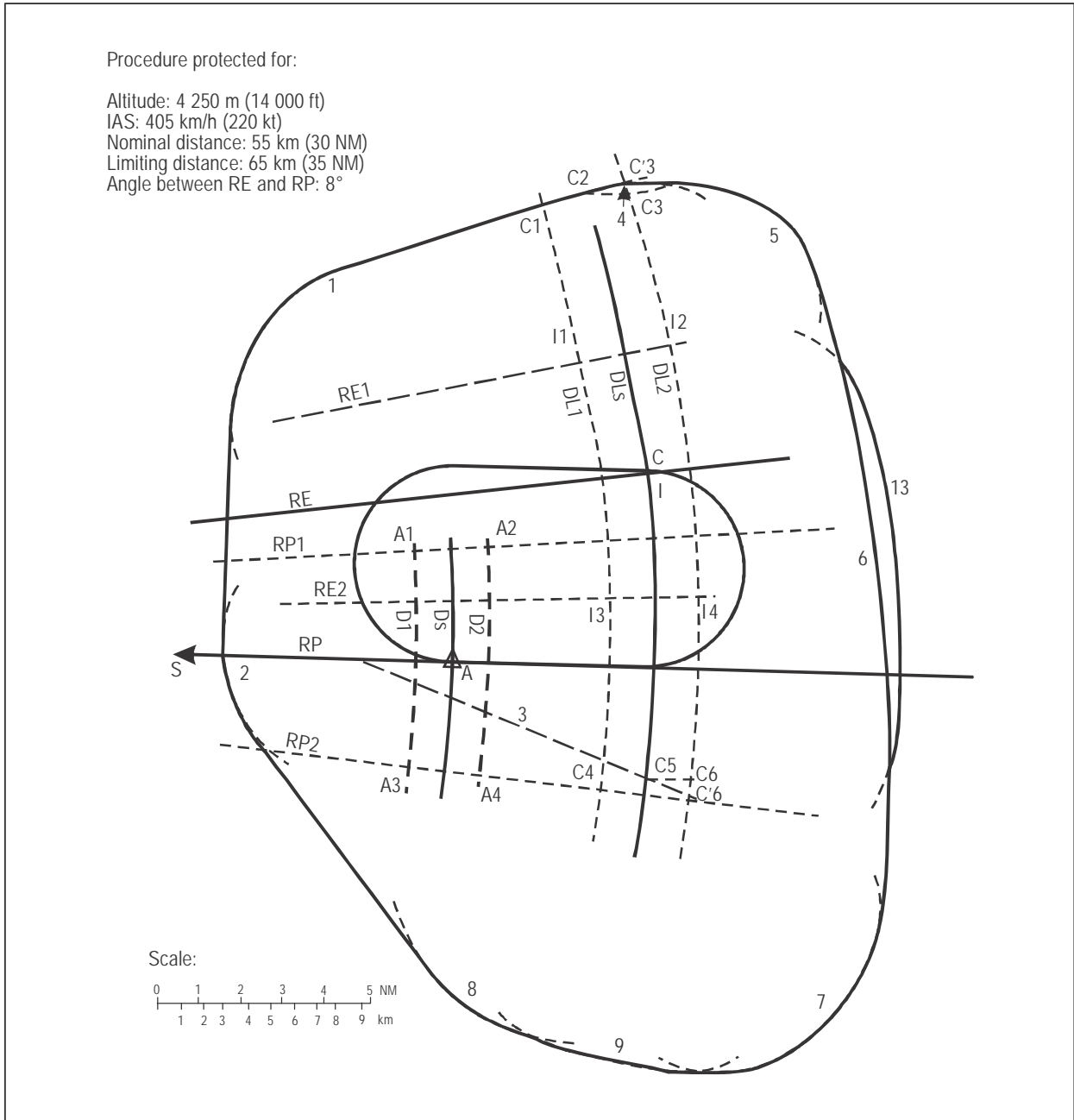

Diagram I-4-3-App C-14. VOR/DME procedure towards the facility — basic area and associated area for reciprocal direct entry to the secondary point

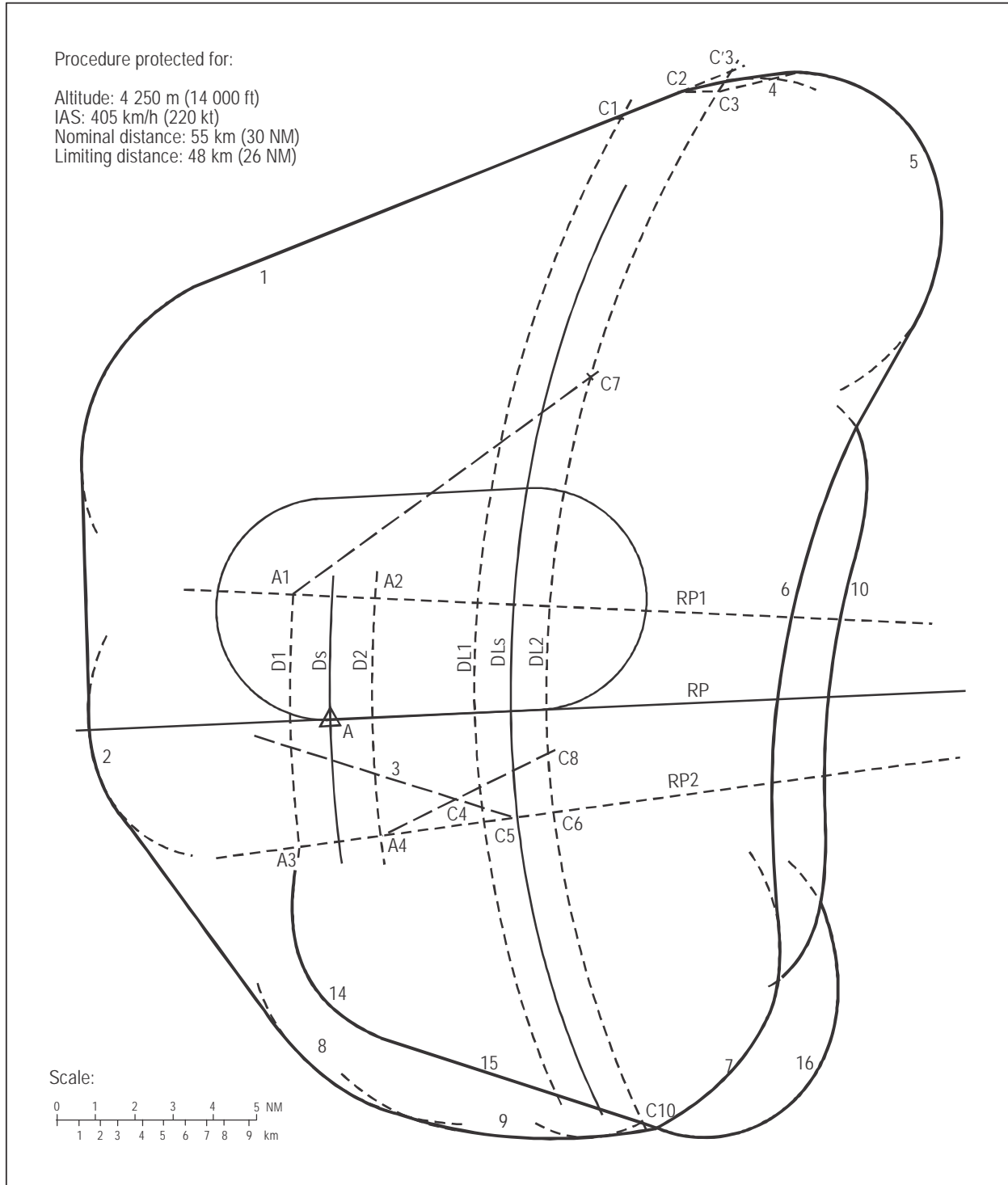

Diagram I-4-3-App C-15. VOR/DME procedure away from the facility — basic area and associated area for entries

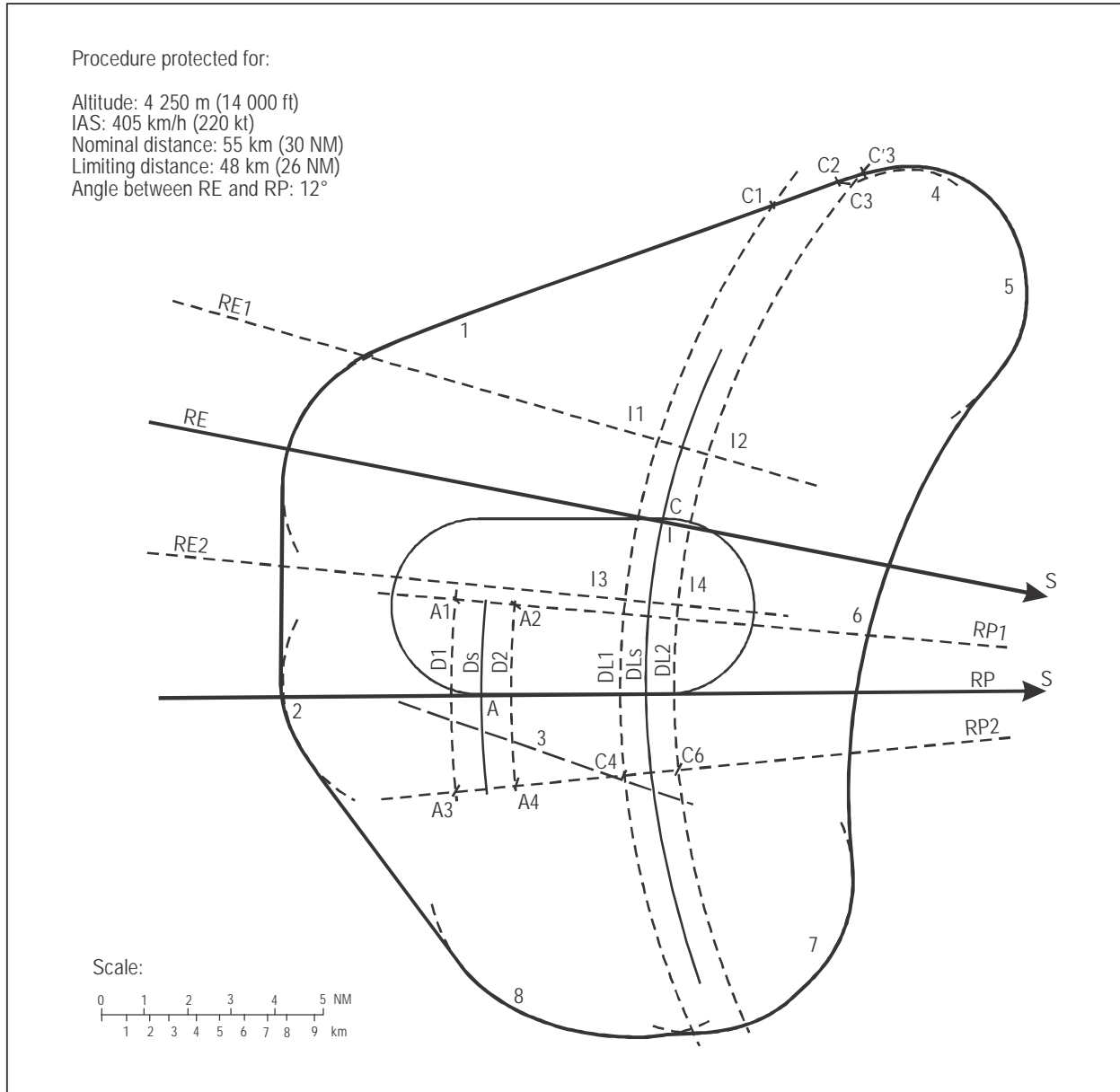

Diagram I-4-3-App C-16. VOR/DME procedure from the facility — basic area and the associated area for reciprocal direct entry to the secondary point

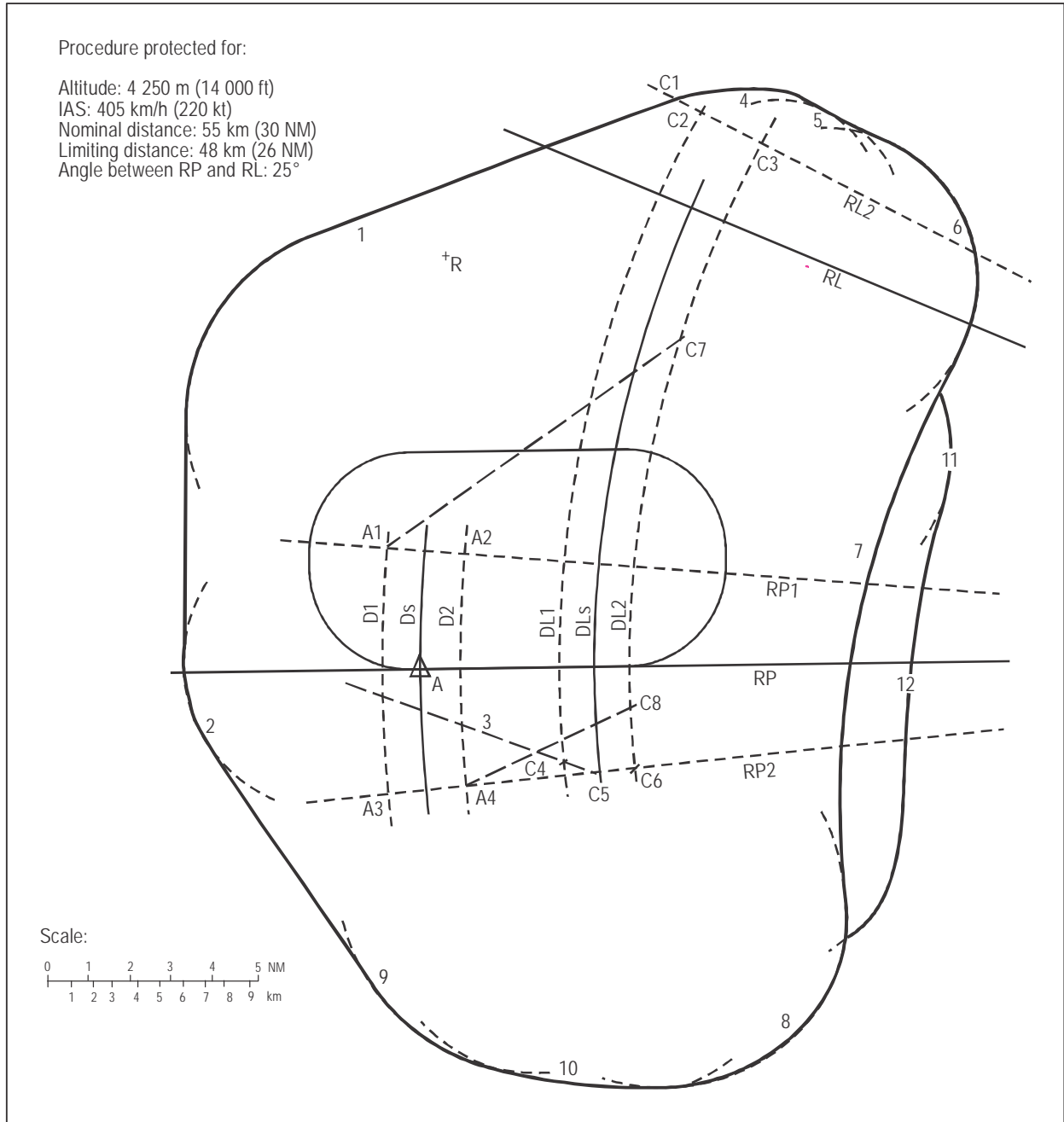

Diagram I-4-3-App C-17. VOR/DME procedure away from the facility with a limiting radial — basic area and associated area for entries

Chapter 4

INTERMEDIATE APPROACH SEGMENT

4.1 GENERAL

4.1.1 The intermediate approach segment blends the initial approach segment into the final approach segment. It is the segment in which aircraft configuration, speed, and positioning adjustments are made for entry into the final approach segment.

4.1.2 There are two types of intermediate approach segments:

- a) one which begins at a designated intermediate approach fix (IF); and
- b) one which begins upon completion of a dead reckoning (DR) track, a reversal or a racetrack procedure.

4.1.3 In both cases, track guidance shall be provided inbound to the final approach fix (FAF) where the intermediate approach segment ends. See Figure I-4-3-2 of Chapter 3 for typical intermediate approach segments.

4.2 ALTITUDE/HEIGHT SELECTION

The minimum altitude/height in the intermediate approach segment shall be established in 100-ft increments or 50-m increments as appropriate.

4.3 INTERMEDIATE APPROACH SEGMENT BASED ON A STRAIGHT TRACK ALIGNMENT

The track to be flown in the intermediate approach segment should normally be the same as the final approach track. Where this is not practicable and the final approach fix in a non-precision procedure is a navigation facility, the intermediate track shall not differ from the final approach track by more than 30° (Cat H, 60°). Where the turn at the FAF is greater than 10° the final approach area should be widened on the outer side of the turn as described in Chapter 6, 6.4.6.3.3, “TP marked by a facility (NDB or VOR)”.

4.3.1 Area

This section deals with the construction of the area of an intermediate approach segment based on a straight track alignment.

4.3.1.1 Length

4.3.1.1.1 The length of the intermediate approach segment shall not be more than 28 km (15 NM) (Cat H, 9.3 km (5.0 NM)), or less than 9.3 km (5.0 NM) (Cat H, 3.7 km (2.0 NM)), (except as provided for in ILS, MLS, RNAV [DME/DME, VOR/DME, GNSS] and radar sections), measured along the track to be flown.

4.3.1.1.2 The optimum length is 19 km (10 NM) (Cat H, 9.3 km (5.0 NM)). A distance greater than 19 km (10 NM) should not be used unless an operational requirement justifies a greater distance. When the angle at which the initial approach track joins the intermediate approach track exceeds 90° (Cat H, 60°), the minimum length of the intermediate approach track is as shown in Table I-4-4-1.

4.3.1.2 Width

In a straight-in approach, the width of the intermediate approach segment tapers from a maximum width of 19 km (10 NM) at the IF to its minimum width at the FAF (or FAP). The segment is divided longitudinally as follows:

- a) a primary area which extends laterally on each side of the track; and
- b) a secondary area on each side of the primary area. (See Figure I-4-3-2 of Chapter 3.)

For calculating secondary area width at a given point, see Section 2, Chapter 1, 1.2.2, “Calculating secondary area width at a given point”.

Note.— See also Appendix B to Chapter 3, “Reduction of the width of a straight initial approach area after the IAF and interface between straight initial approach area and reversal procedure areas” for possible reduction of the width of the initial approach area.

4.3.2 Obstacle clearance

4.3.2.1 A minimum of 150 m (492 ft) of obstacle clearance shall be provided in the primary area of the intermediate approach segment. In the secondary area, 150 m (492 ft) of obstacle clearance shall be provided at the inner edge, reducing to zero at the outer edge. See Figure I-2-1-1 of Section 2, Chapter 1. For calculating obstacle clearance at a given point, see Section 2, Chapter 1, 1.3, “Obstacle clearance”.

4.3.2.2 The altitudes/heights selected by application of the obstacle clearance specified shall be rounded upwards to the next 50 m or 100 ft as appropriate.

4.3.3 Procedure altitude/height and descent gradient

4.3.3.1 Because the intermediate approach segment is used to prepare the aircraft speed and configuration for entry into the final approach segment, this segment should be flat or at least have a flat section contained within the segment.

4.3.3.2 If a descent is necessary the maximum permissible gradient will be 5.2 per cent (Cat H, 10 per cent or, if the intermediate approach speed is restricted to 165 km/h IAS (90 kt IAS), 13.2 per cent). In this case, a horizontal segment with a minimum length of 2.8 km (1.5 NM) should be provided prior to the final approach for Cat C and D aircraft. For procedures specific to Cat A and B aircraft, this minimum length may be reduced to 1.9 km (1.0 NM). This should allow sufficient distance for aircraft to decelerate and carry out any configuration changes necessary before final approach segment.

Note.— Referring to 4.3.3.1 and 4.3.3.2, to fly an efficient descent profile, the pilot may elect to configure whilst in a continuous descent along this segment.

4.3.3.3 Procedure altitudes/heights in the intermediate segment shall be established to allow the aircraft to intercept a prescribed final approach descent.

4.4 INTERMEDIATE SEGMENT WITHIN A REVERSAL OR RACETRACK PROCEDURE

4.4.1 General

The intermediate approach segment begins upon interception of the intermediate approach track. Criteria are the same as those shown in 4.3, “Intermediate approach segment based on a straight track alignment”, except as specified in the paragraphs below.

4.4.2 Area width

When used with the reversal or racetrack procedure, the intermediate segment width expands uniformly from the width of the final approach segment at the navigation facility to 9.3 km (5.0 NM) on each side of the track at 28 km (15 NM) from the facility, for a total width of 18.6 km (10 NM). Beyond 28 km (15 NM) the area remains 19 km (10 NM) wide. See Figure I-4-4-2.

The intermediate approach area is divided into primary and secondary areas as specified in Section 2, Chapter 1, 1.2, “Areas”.

4.4.3 Area length

When an IF is available the intermediate approach segment is normally 19 km (10 NM) long (Cat H, maximum length of 9.3 km (5 NM)). See Figure I-4-4-1. When no IF is available, the intermediate approach area shall extend to the far boundary of the reversal procedure primary area. See Figures I-4-4-2 and I-4-4-3.

4.4.4 Turn not at the facility

If the reversal or racetrack procedure is predicated on a FAF which is not located at the facility, the intermediate approach area extends 9.3 km (5.0 NM) on each side of the intermediate track at 28 km (15 NM) from the facility, and tapers uniformly to the width of the final approach area at the FAF. See Figure I-4-4-3.

4.4.5 Descent gradient

The constraints specified for the inbound track in Table I-4-3-1 apply.

Table I-4-4-1. Minimum intermediate track length

<i>Interception angle (degrees)</i>	<i>Minimum track length</i>
91 — 96	11 km (6 NM)
97 — 102	13 km (7 NM)
103 — 108	15 km (8 NM)
109 — 114	17 km (9 NM)
115 — 120	19 km (10 NM)
Cat H	
61 — 90	5.6 km (3 NM)
91 — 120	7.4 km (4 NM)

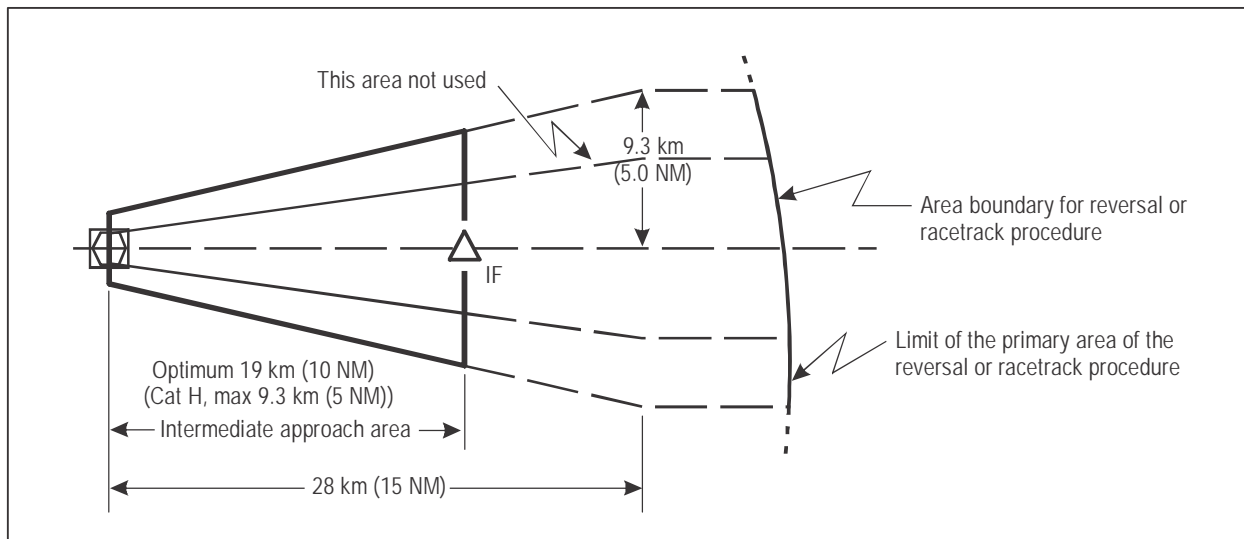

Figure I-4-4-1. Intermediate approach area within reversal or racetrack procedure with a fix

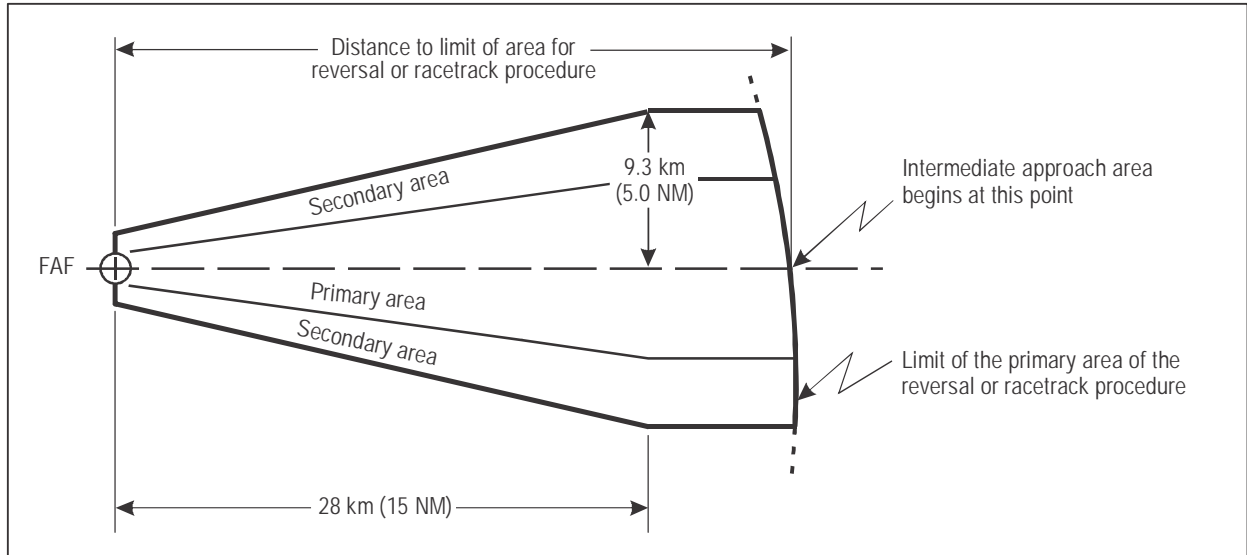

Figure I-4-4-2. Intermediate approach area within reversal or racetrack procedure with no IF

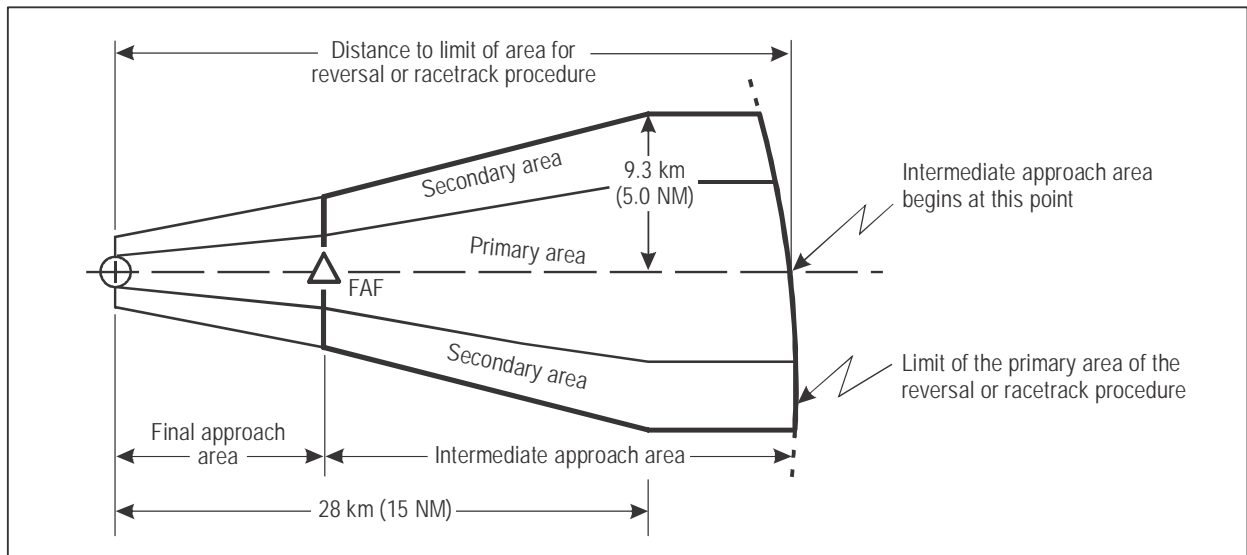

Figure I-4-4-3. Intermediate approach area within reversal or racetrack procedure based on FAF (not the facility)

Chapter 5

FINAL APPROACH SEGMENT

5.1 GENERAL

5.1.1 States are encouraged to implement approach procedures that have vertical guidance.

5.1.2 In the final approach segment, alignment and descent for landing are carried out. The instrument part of the final approach segment begins at the final approach fix, and ends at the missed approach point (MAPt). Track guidance shall be provided for the instrument phase of the final approach segment. Final approach may be made:

- a) to a runway for a straight-in landing; or
- b) to an aerodrome for a circling approach.

5.1.3 The final approach segment should be aligned with a runway whenever possible. All final approaches with a FAF have an optimum length of 9.3 km (5 NM). The minimum final approach segment length shall not be less than 5.6 km (3.0 NM). This value also applies to the minimum distance from the FAF to the threshold except for non-RNAV procedures constrained by existing installations. Exceptions apply for:

- a) RNAV procedures with large track changes at the FAF for Category D, D_L and E aircraft (see Table I-4-5-1); and
- b) Cat H aircraft (see Table I-4-5-1).

5.2 ALIGNMENT

5.2.1 The final approach and its track guidance should be aligned with a runway whenever possible. An offset final approach increases the complexity of pilot operation. Consequently it should only be designed when siting or obstacle problems permit no other option. An offset final approach track shall not be established as a noise abatement measure. When runway aligned track guidance is not possible it may be offset up to 5 degrees without OCA/H penalty (see 5.4.3.1, "Aligned straight-in approach"). Beyond these limits (or where other requirements cannot be met) a circling approach shall be used.

5.2.2 Straight-in approach

5.2.2.1 This paragraph contains the alignment criteria for non-precision approaches. The alignment criteria for approaches other than non-precision are found in the applicable sections.

5.2.2.2 *Final approach with track not intersecting the extended runway centre line.* A final approach which does not intersect the extended centre line of the runway (θ equal to or less than 5°) may also be established, provided such track lies within 150 m laterally of the extended runway centre line at a distance of 1 400 m outward from the runway threshold (see Figure I-4-5-1).

5.2.2.3 *Final approach with track intersecting the extended runway centre line.*

5.2.2.3.1 *Maximum angle.* For a straight-in approach, the angle formed by the final approach track and the runway centre line shall not exceed:

- a) 30° for procedures restricted to Cat A and B aircraft ; and
- b) 15° for other aircraft categories.

5.2.2.3.2 *Minimum distance.* The distance between the runway threshold and the point at which the final approach track intersects the runway centre line shall not be less than 1 400 m (see Figure I-4-5-1).

5.2.2.4 *Final approach track angle for helicopters.* For helicopters, the final approach track shall intersect the final approach and take-off area (FATO) axis at an angle not exceeding 30° and at a distance not less than 400 m from the FATO. When the final approach track does not intersect the extended axis of the FATO, the track shall lie within 75 m of it laterally at a point 400 m from the FATO.

5.2.3 Circling approach

The circling approach contains the visual phase of flight after completing an instrument approach, to bring an aircraft into position for landing on a runway that for operational reasons is not suitably located for straight-in approach. In addition, when the final approach track alignment or the descent gradient does not meet the criteria for a straight-in landing, only a circling approach shall be authorized and the track alignment should ideally be made to the centre of the landing area. When necessary, the final approach track may be aligned to pass over some portion of the usable landing surface. In exceptional cases, it may be aligned beyond the aerodrome boundary, but in no case beyond 1.9 km (1.0 NM) from the usable landing surface (see Figure I-4-5-2).

5.3 DESCENT GRADIENT

5.3.1 Gradient/angle limits

5.3.1.1 *Minimum/optimum descent gradient/angle.* The minimum/optimum descent gradient is 5.2 per cent for the final approach segment of a non-precision approach with FAF (3° for a precision approach or approach with vertical guidance). Descent gradients steeper than the optimum should not be used unless all other means to avoid obstacles have been attempted since these steeper descent gradients may result in rates of descent which exceed the recommended limits for some aircraft on final approach.

5.3.1.2 *Maximum descent gradient/angle.* This paragraph provides guidance regarding the maximum descent gradient/angle to be applied for approach procedures. When, because of obstacle clearance reasons, an approach procedure meeting the maximum descent gradient/angle requirement as specified in this paragraph cannot be implemented, then consideration should first be given to more advanced types of approaches that provide vertical guidance and may allow the descent/angle to stay within the limits. If this is not feasible for operational reasons and it is opted for an approach procedure that exceeds the maximum descent gradient/angle then the approach procedure shall be subject to an aeronautical study and requires special approval by the national competent authority. See Appendix B to this chapter for guidance on steep angle non-precision approaches. See Appendix B to Part II, Section 1, Chapter 1 for guidance on steep angle precision approaches.

The maximum descent gradient/angle is:

- a) for non-precision procedures with FAF:

6.5 per cent for a non-precision approach for Cat A and B aircraft;

6.1 per cent for Cat C, D and E aircraft; and

10 per cent for Cat H aircraft. However, where an operational need exists and the magnitude of turn at the FAF is less than or equal to 30°, a gradient of as much as 13.2 per cent may be authorized, provided the final approach speed is restricted to a maximum of 130 km/h IAS (70 kt IAS), and provided the gradient used is depicted on approach charts.

- b) for a non-precision approach with no FAF, see Table I-4-5-2;

- c) 3.5° for an approach with vertical guidance; and

- d) for precision approaches:

3.5° for a Cat I precision approach; and

3° for Cat II and III precision approaches.

5.3.2 Determination of the descent gradient for a non-precision approach with FAF

The descent gradient (g) for a non-precision approach with FAF is computed using the equation: $g = h/d$. The values for h and d are defined as follows:

- a) For a straight-in approach use:

d = the horizontal distance from the FAF to the threshold (Cat H, LDAH); and

h = the vertical distance between the altitude/height over the FAF and the elevation 15 m (50 ft) (Cat H, 10.7 m (35 ft) over the threshold).

- b) For a circling approach use:

d = the distance from the FAF to the first usable portion of the landing surface; and

h = the vertical distance between the altitude/height over the FAF and the circling OCA/H.

- c) For an approach where a stepdown fix (SDF) is used in the final segment, two descent gradients are calculated (g_1 and g_2).

- 1) In calculating the gradient (g_1) between the FAF and the stepdown fix:

d_1 = the horizontal distance from the FAF to the SDF; and

h_1 = vertical distance between the height of the FAF and the height of the SDF.

- 2) In calculating the gradient (g_2) between the stepdown fix and the approach runway threshold:

d_2 = the horizontal distance from the SDF to the threshold; and

h_2 = the vertical distance between the altitude/height at the SDF and the elevation 15 m (50 ft) (Cat H, 10.7 m (35 ft) over the threshold).

For short runways (Code 1 and 2) the height above threshold can be as low as 12 m (40 ft).

5.4 OBSTACLE CLEARANCE ALTITUDE/HEIGHT (OCA/H)

5.4.1 General

5.4.1.1 This paragraph describes the application of OCA/H for the different types of approach and its relationship to the aerodrome operating minima. The OCA/H is based on clearing obstacles by a specified minimum obstacle clearance (MOC). In some situations, an additional margin is added to the MOC, or an absolute lower limit should be applied, which will override the OCA/H. See 5.4.5, “MOC and OCA/H adjustments”, and Figure I-4-5-3 a) to c). Table I-4-5-3 does not apply to helicopter procedures.

5.4.1.2 Precision approach procedures/approach procedures with vertical guidance (APV)

- a) *OCA/H*. In a precision approach procedure (or APV), the OCA/H is defined as the lowest altitude/height at which a missed approach must be initiated to ensure compliance with the appropriate obstacle clearance design criteria.
- b) *Reference datum*. The OCA is referenced to mean sea level (MSL). The OCH is referenced to the elevation of the relevant runway threshold.

5.4.1.3 Non-precision approach procedure (straight-in)

- a) *OCA/H*. In a non-precision approach procedure, the OCA/H is defined as the lowest altitude or alternatively the lowest height below which the aircraft cannot descend without infringing the appropriate obstacle clearance criteria.
- b) *Reference datum*. The OCA is referenced to mean sea level (MSL). The OCH is referenced to
 - 1) aerodrome elevation; or
 - 2) runway threshold elevation when the threshold elevation is more than 2 m (7 ft) below the aerodrome elevation.

5.4.1.4 Visual manoeuvring (circling) procedure

- a) *OCA/H*. Same as in the non-precision approach procedure.
- b) *Reference datum*. The OCA is referenced to mean sea level (MSL). The OCH is referenced to the aerodrome elevation.

5.4.1.5 *Aerodrome operating minima*

OCA/H is one of the factors taken into account in establishing operating minima for an aerodrome in accordance with Annex 6. See Figure I-4-5-3 a) to c).

5.4.2 OCA/H for precision approaches and approach procedures with vertical guidance

The determination of OCA/H in precision approaches and approach procedures with vertical guidance is described in Part II, Section 1 and Part III, Section 3, Chapters 4 to 6.

5.4.3 OCA/H for non-precision approach (straight-in)

5.4.3.1 *Aligned straight-in approach*

The OCA/H for a straight-in, non-precision approach where the angle between the track and the extended runway centre line does not exceed 5 degrees shall provide the following minimum obstacle clearance (MOC) over the obstacles in the final approach area:

- a) 75 m (246 ft) with FAF; and
- b) 90 m (295 ft) without FAF.

The OCA/H shall also ensure that missed approach obstacle clearance is provided. See Chapter 6, “Missed approach segment”. A straight-in OCA/H shall not be published where final approach alignment or descent gradient criteria are not met. In this case, only circling OCA/H shall be published.

5.4.3.2 *Non-aligned straight-in approach*

For a final approach where the track intersects the extended runway centre line, OCA/H varies according to the interception angle. The OCH of the procedure shall be equal to or greater than the lower limits shown in Table I-4-5-3. The calculations used to arrive at these values appear in Appendix A to this chapter. For nominal descent gradients above 5.2 per cent, increase by 18 per cent the lower limits shown in the table for each per cent of gradient above 5.2 per cent.

5.4.4 OCA/H for visual manoeuvring (circling)

The OCA/H for visual manoeuvring (circling) shall provide the minimum obstacle clearance (MOC) over the highest obstacle in the visual manoeuvring (circling) area as specified in Table I-4-7-3 of Chapter 7. It shall also be:

- a) above the lower limits (also specified in Table I-4-7-3); and
- b) not less than the OCA/H calculated for the instrument approach procedure which leads to the circling manoeuvre. See Chapter 7, “Visual manoeuvring (circling) area”.

Circling procedures are not provided for helicopters. When a helicopter instrument approach is followed by visual manoeuvring, the OCH shall not be less than 75 m (246 ft). See Chapter 7.

5.4.5 MOC and OCA/H adjustments

5.4.5.1 In certain cases the MOC and/or the OCA/H must be increased. This may involve:

- a) an additional margin that is added to MOC;
- b) a percentage increase in OCA/H; and
- c) applying a lower limit (a minimum value) to OCA/H; as described below.

5.4.5.2 Additional margin applied to MOC

5.4.5.2.1 *Mountainous areas.* See 1.7, “Increased altitudes/heights for mountainous areas” in Section 2, Chapter 1 for guidance on increased MOC in mountainous areas.

5.4.5.2.2 These criteria are applicable to non-precision approach procedures only.

5.4.5.3 Percentage increase in OCA/H

5.4.5.3.1 *Remote altimeter setting.* When the altimeter setting is derived from a source other than the aerodrome, and more than 9 km (5 NM) remote from the threshold, the OCA/H shall be increased at a rate of 0.8 m for each kilometre in excess of 9 km (5 ft for each nautical mile in excess of 5 NM) or a higher value if determined by local authority. In mountainous areas or other areas where reasonably homogenous weather cannot always be expected, a procedure based on a remote altimeter setting source should *not* be provided. In all cases where the source of the altimeter setting is more than 9 km (5 NM) from the threshold, a cautionary note should be inserted on the instrument approach chart identifying the altimeter setting source.

5.4.5.3.2 Remote altimeter setting source (RASS) in mountainous areas

- a) The use of RASS in mountainous areas requires additional calculations to determine the correct OCA/H. The calculation uses the formula

$$\text{OCA/H} = 2.3x + 0.14z \text{ (non SI)}$$

$$\text{OCA/H} = 0.4x + 0.14z \text{ (SI)}$$

where: OCA/H is the RASS increased altitude/height value (m/ft);

x is the distance from the RASS to the landing area (km/NM); and

z is the difference in elevation between the RASS and the landing area (m/ft).

These formulas are used where no intervening terrain adversely influences atmospheric pressure patterns. The use of this criteria is limited to a maximum distance of 138 km (75 NM) laterally or an elevation differential of 1 770 m (6 000 ft) between the RASS and the landing area. An example calculation in nautical miles and feet is illustrated in Figure I-4-5-4.

- b) Where intervening terrain adversely influences atmospheric pressure patterns, the OCA/H shall be evaluated in an Elevation Differential Area (EDA). The EDA is defined as the area within 9 km (5 NM) each side of a line connecting the RASS and the landing area, including a circular area enclosed by a 9 km (5 NM) radius at each

end of the line. In this case, z becomes the terrain elevation difference (m/ft) between the highest and lowest terrain elevation points contained in the EDA. An example of a calculation in nautical miles and feet is illustrated in Figure I-4-5-5.

5.4.5.4 Lower limit (a minimum value) applied to OCA/H

- a) *Forecast altimeter setting.* When the altimeter setting to be used with procedures is a forecast value obtained from the appropriate meteorological office, the OCA/H shall be increased by a value corresponding to the forecasting tolerance for the location as agreed by the meteorological office for the time periods involved. Procedures which require the use of forecast altimeter setting shall be suitably annotated on the approach charts.
- b) *Final approach track intersecting the extended runway centre line between 5° and 30°.* When the final approach track intersects the extended runway centre line between 5° and 30° a lower limit is applied to OCA/H (5.4.3.2, “Non-aligned straight-in approach”).
- c) *Final approach track intersecting the extended runway centre line at more than 30° or descent gradient exceeding 6.5 per cent.* When the final approach track intersects the extended runway centre line at more than 30°, or the descent gradient exceeds 6.5 per cent, the OCA/H for visual manoeuvring (circling) becomes the lower limit and is applied to the approach procedure.
- d) *Visual manoeuvring (circling).* For visual manoeuvring (circling) a lower limit consisting of the OCA/H for the associated instrument approach procedure is applied (see 5.4.4, “OCA/H for visual manoeuvring (circling)”).

5.4.6 Protection for the visual segment of the approach procedure

5.4.6.1 All new straight-in instrument approach procedures published on or after 15 March 2007 shall be protected for obstacles in the visual segment. For this purpose no obstacles, except subject to 5.4.6.4, shall penetrate a Visual Segment Surface (VSS) laterally, defined as follows:

- a) for procedures with localizer or localizer look-alike lateral guidance (LOC only, APV I, APV II and PA approaches) where the final approach track is aligned with the runway centre line, with a base width equal to the inner approach surface as defined in Annex 14, originating 60 m prior to the runway threshold, extending parallel to the extended runway centre line, and terminating at the point where the height of the surface reaches the OCH (see Figure I-4-5-6 a)); and
- b) for all other straight-in instrument approach procedures:
 - 1) a base width equal to the runway strip width originating 60 m prior to the runway threshold, splaying 15 per cent on either side of the extended runway centre line, and terminating at the point where the height of the surface reaches the OCH (see Figure I-4-5-6-b));
 - 2) where the final approach course is offset and intersects the extended runway centre line, the splay on the side closest to the final approach course is increased by the offset angle (see Figure I-4-5-7); and
 - 3) where the final approach course is offset but does not intersect the extended runway centre line, the splay closest to the final approach course is increased by an amount equal to the final approach course offset at 1 400 m from the runway threshold (see Figure I-4-5-8).

5.4.6.2 Vertically, the VSS originates at the runway threshold height and has a slope of 1.12 degrees less than the promulgated approach procedure angle.

5.4.6.3 Straight-in instrument approach procedures published before 15 March 2007 shall be protected in the visual segment by means of the VSS after the periodical review of the procedure, but not later than 15 March 2012.

5.4.6.4 If the VSS is penetrated, the approach procedure shall not be promulgated without an aeronautical study. Mitigation action as a result of such a study may result in the removal or lowering of the obstacle, an increase of the descent gradient/angle, and/or runway threshold displacement. Obstacles with a height less than 15 m above the threshold may be disregarded when assessing the VSS. Temporary moving obstacles such as aircraft holding at the runway hold-point are allowed.

5.4.6.5 Any penetration of the VSS shall be identified on the instrument approach chart.

5.5 PROMULGATION

5.5.1 *Descent gradients/angles for charting.* Descent gradients/angles for charting shall be promulgated to the nearest one-tenth of a per cent/degree. Descent gradients/angles shall originate at a point 15 m (50 ft) above the landing runway threshold. For precision approaches different origination points may apply (see RDH in specific chapters). For non-precision approaches at short runways (Code 1 and 2) the height above threshold can be as low as 12 m (40 ft). Earth curvature is not considered in determining the descent gradient/angle.

5.5.2 *Descent angles for database coding.* Paragraph 5.5.1 applies with the exception that descent angles shall be published to the nearest one-hundredth of a degree.

5.5.3 Both the procedure altitude/height and the minimum altitude for obstacle clearance shall be published. In no case shall the procedure altitude/height be lower than the minimum altitude for obstacle clearance.

5.5.4 The designed stabilized descent path shall clear the stepdown fix minimum obstacle clearance altitude. This can be achieved by increasing the descent gradient by:

- a) increasing the procedure altitude/height at the FAF; or (if a) is not possible)
- b) moving the FAF toward the landing threshold.

5.5.5 *Publication of OCA/H.* An OCA and/or an OCH shall be published for each instrument approach and circling procedure. For non-precision approach procedures, either value shall be expressed in 5-m or 10-ft increments by rounding up as appropriate.

Table I-4-5-1. Minimum length of final approach segment

Aircraft category	Magnitude of turn over FAF			
	10° or less	20°	30°	60°
D and D _L	5.6 km (3.0 NM)	5.6 km (3.0 NM)	6.5 km (3.5 NM)	
E	5.6 km (3.0 NM)	6.5 km (3.5 NM)	7.4 km (4.0 NM)	
H	1.9 km (1.0 NM)	2.8 km (1.5 NM)	3.7 km (2.0 NM)	5.6 km (3.0 NM)

The values in this table may be interpolated. If turns of more than 30° (Cat H, 60°) are required, or if the minimum lengths specified in the table are not available for the procedure, straight-in minimums are not authorized and only the circling OCA/H should be published.

Table I-4-5-2. Rate of descent in the final approach segment of a non-precision procedure with no FAF

Aircraft categories	Rate of descent	
	Maximum	Minimum
Cat A/B	200 m/min (655 ft/min)	120 m/min (394 ft/min)
Cat H	230 m/min (755 ft/min)	N/A
Cat C/D/E	305 m/min (1 000 ft/min)	180 m/min (590 ft/min)

Table I-4-5-3. Lower limit on OCH

Aircraft category	Lower limit on OCH (m (ft))	
	5° < θ ≤ 15°	15° < θ ≤ 30°
A	105 (340)	115 (380)
B	115 (380)	125 (410)
C	125 (410)	
D	130 (430)	
E	145 (480)	

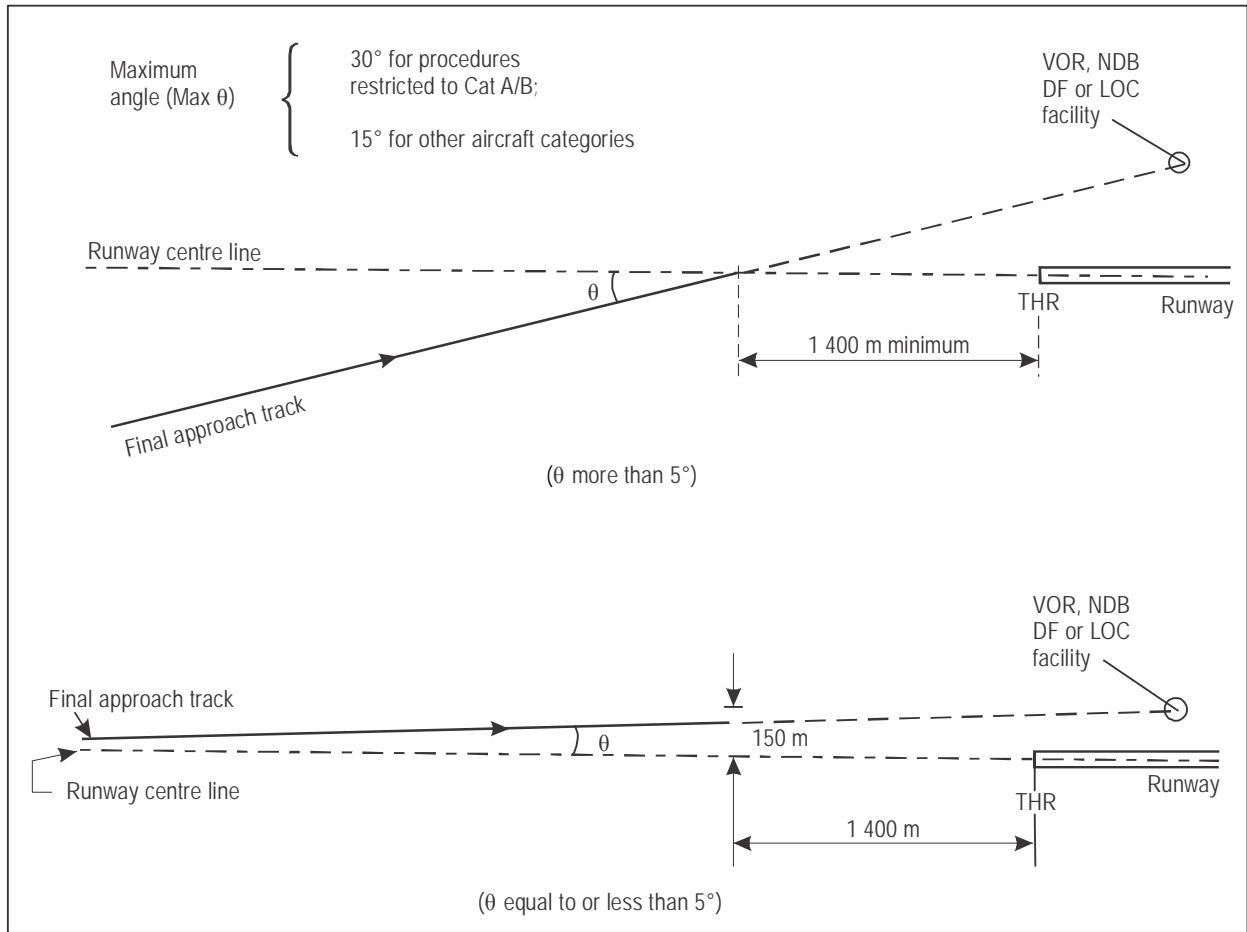

Figure I-4-5-1. Final straight-in approach alignment

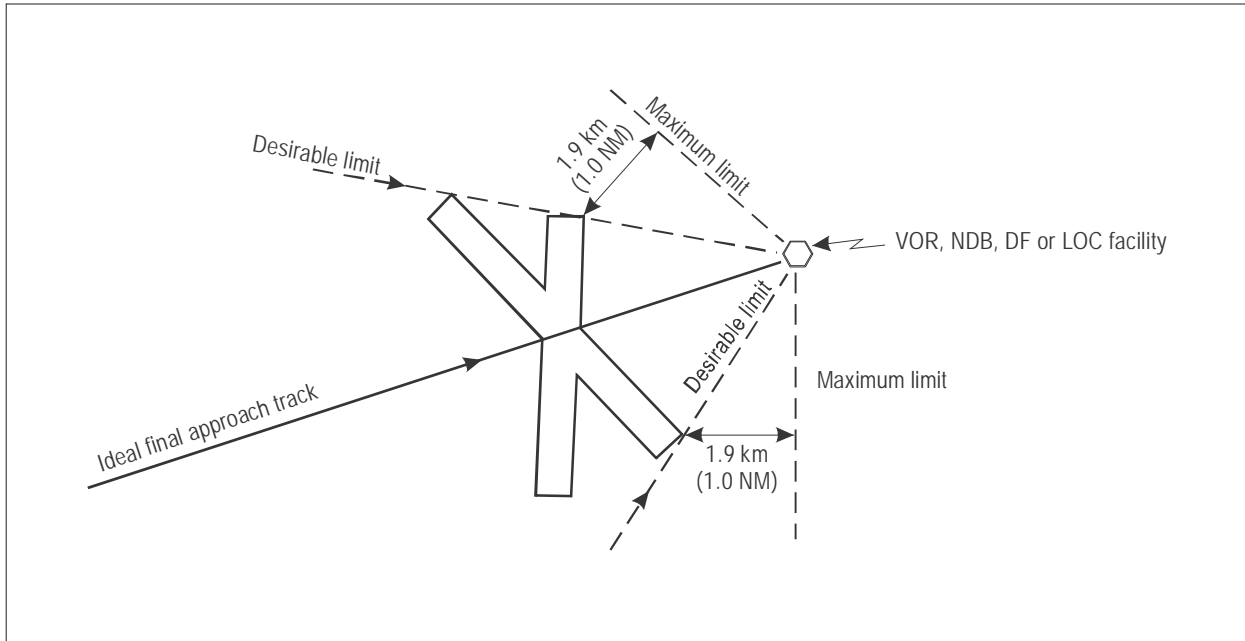

Figure I-4-5-2. Final circling approach alignment

PRECISION APPROACH

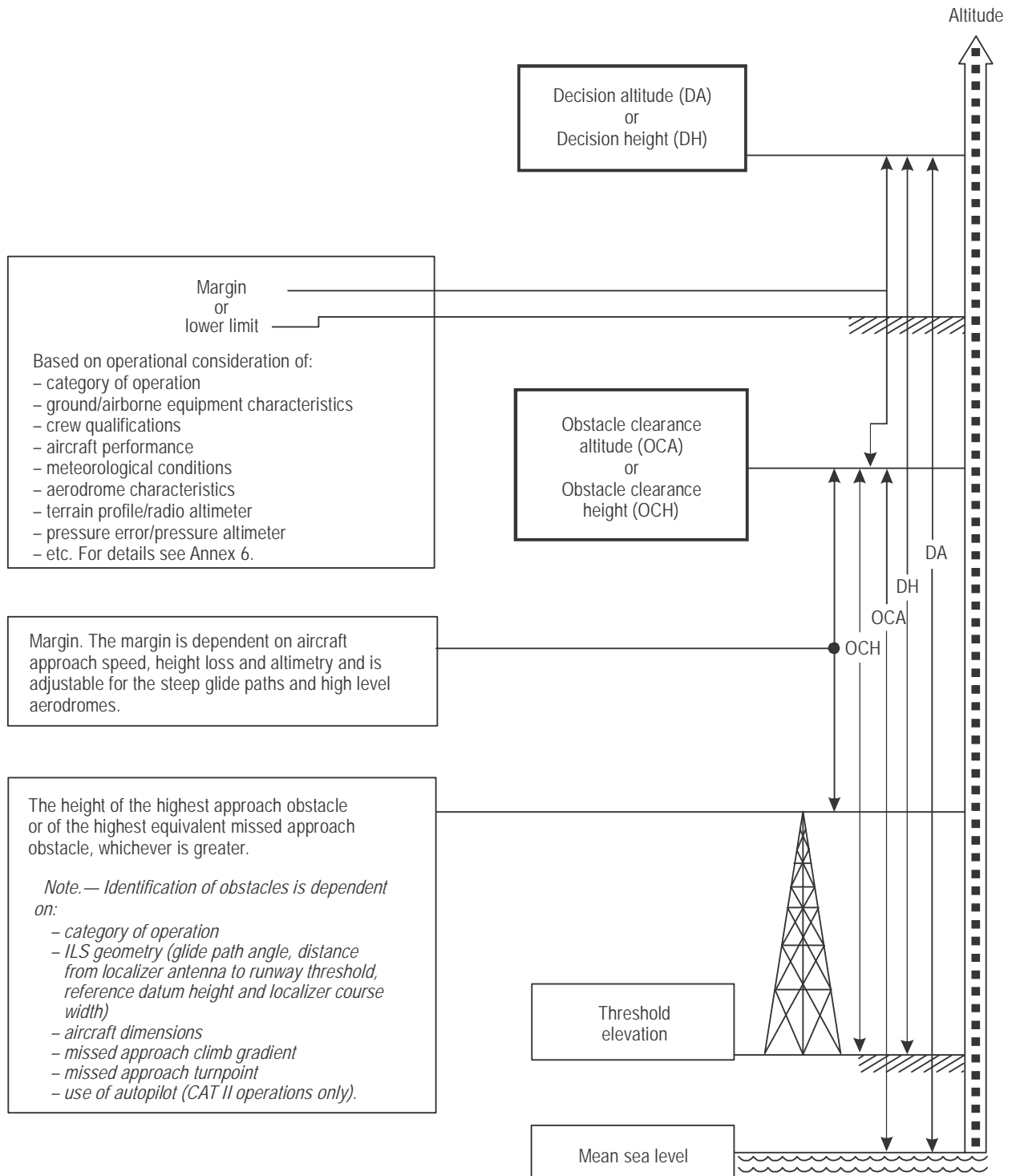

Figure I-4-5-3 a). Relationship of obstacle clearance altitude/height (OCA/H) to decision altitude/height (DA/H) for precision approaches
This figure does not apply to Category H. See Section 4, Chapter 7.

NON-PRECISION APPROACH

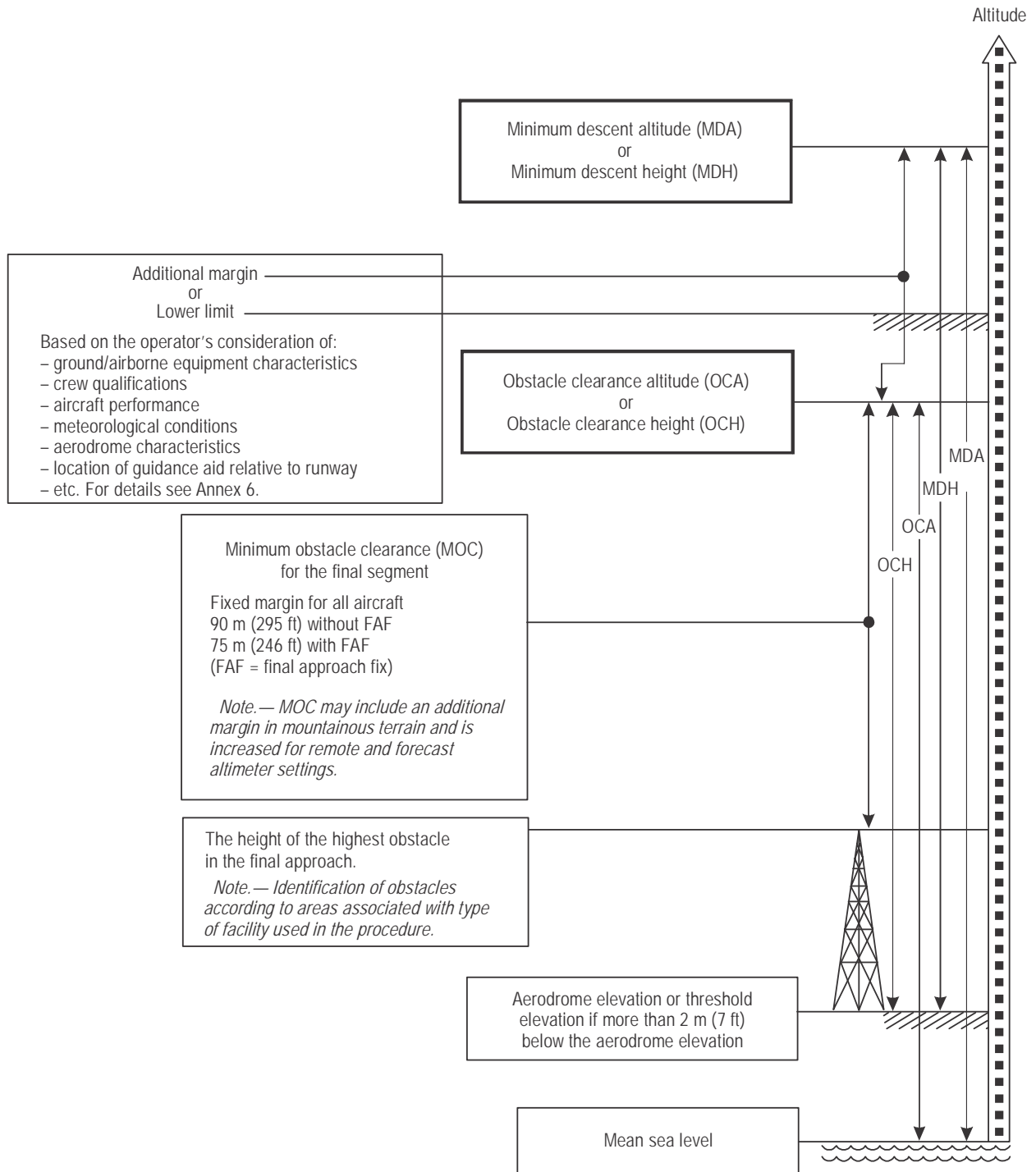

Figure I-4-5-3 b). Relationship of obstacle clearance altitude/height (OCA/H) to minimum descent altitude/height (MDA/H) for non-precision approaches (example with a controlling obstacle in the final approach)

VISUAL MANOEUVRING (CIRCLING)

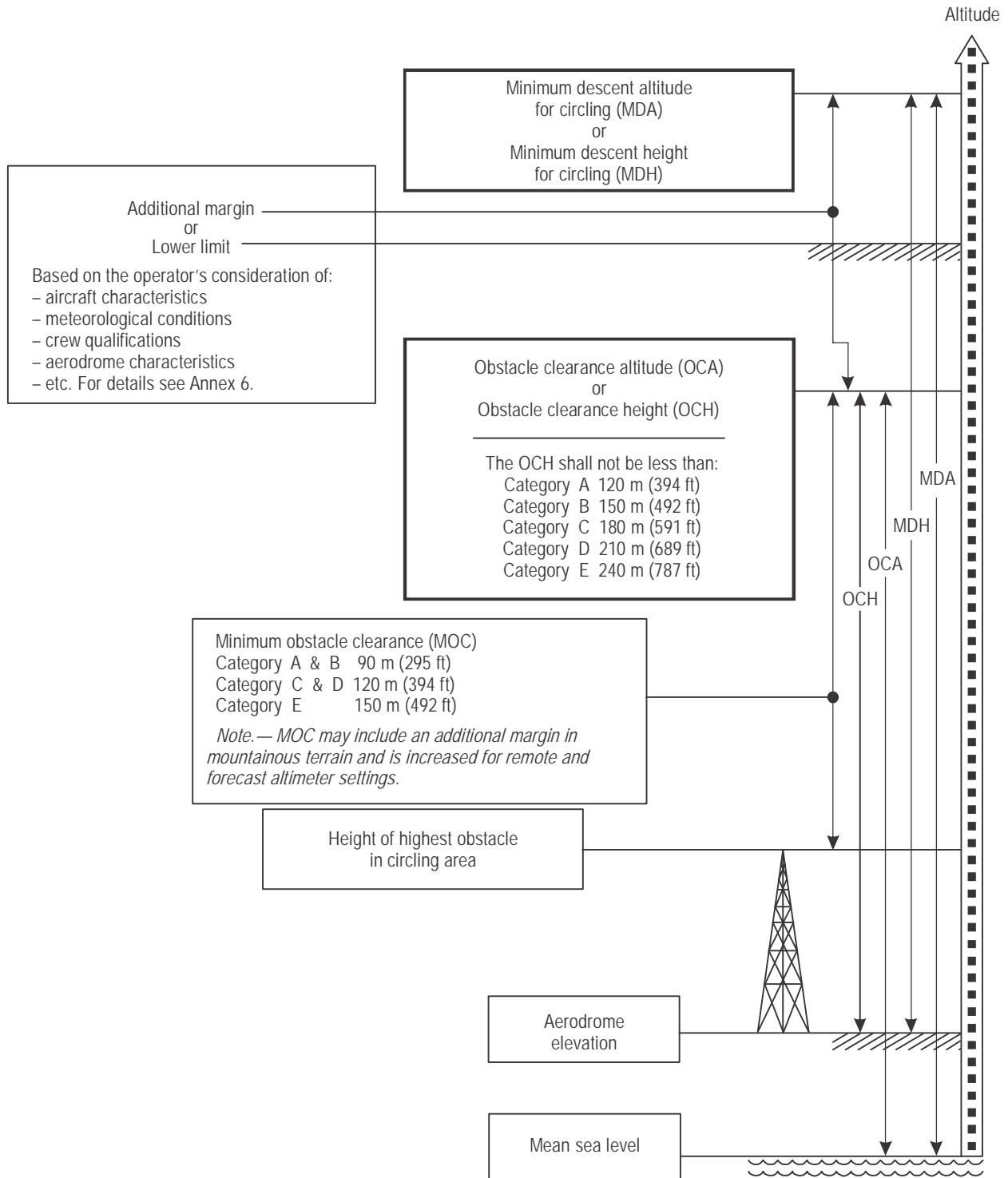

Figure I-4-5-3 c). Relationship of obstacle clearance altitude/height (OCA/H) to minimum descent altitude/height (MDA/H) for visual manoeuvres (circling)

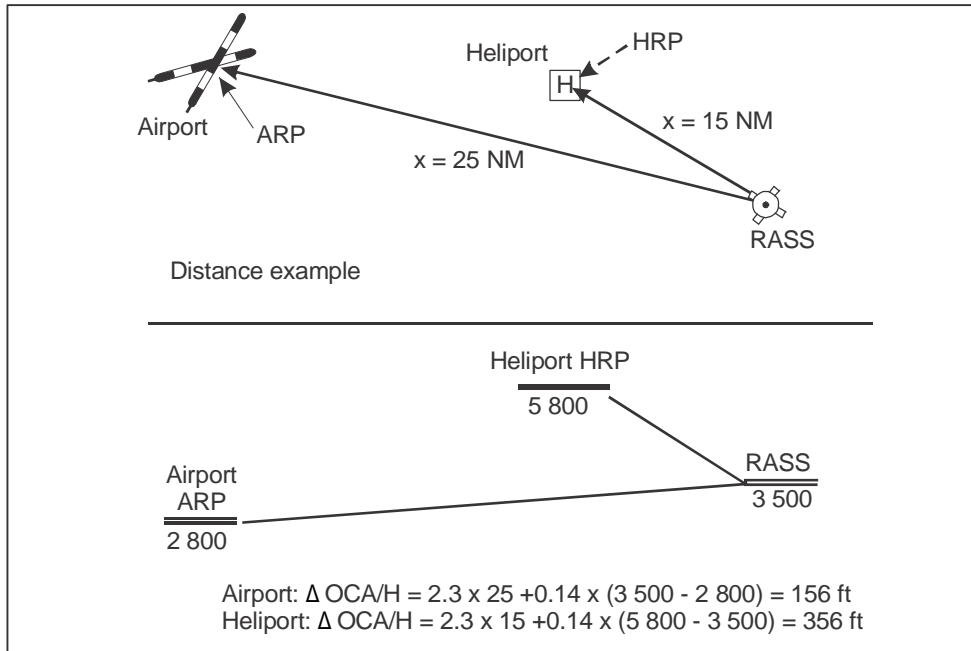

Figure I-4-5-4. Remote altimeter setting source (RASS) in mountainous areas

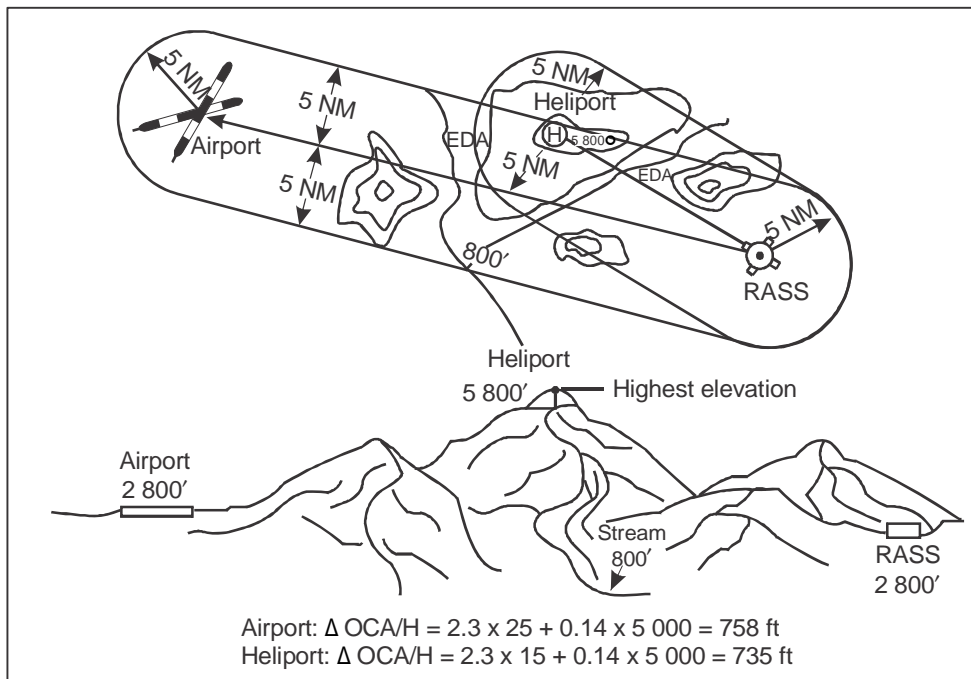

Figure I-4-5-5. Elevation differential area (EDA)

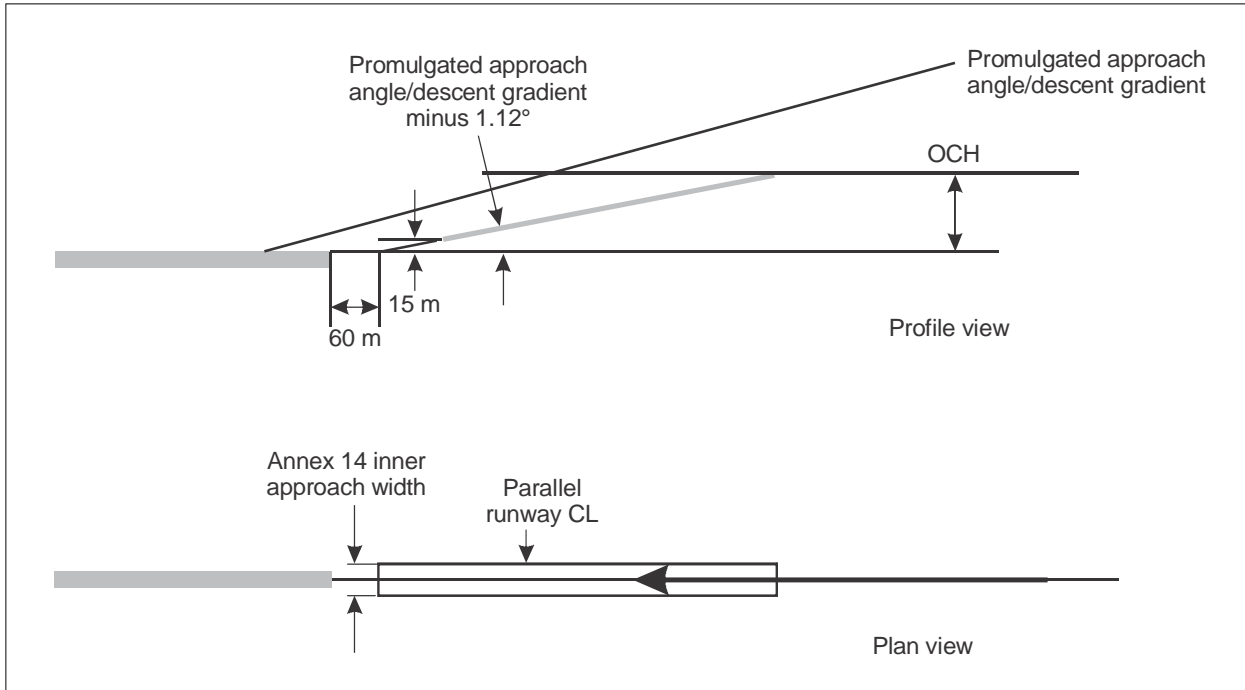

Figure I-4-5-6 a). Visual segment surface procedures with localizer or localizer look-alike lateral guidance aligned with Rwy CL

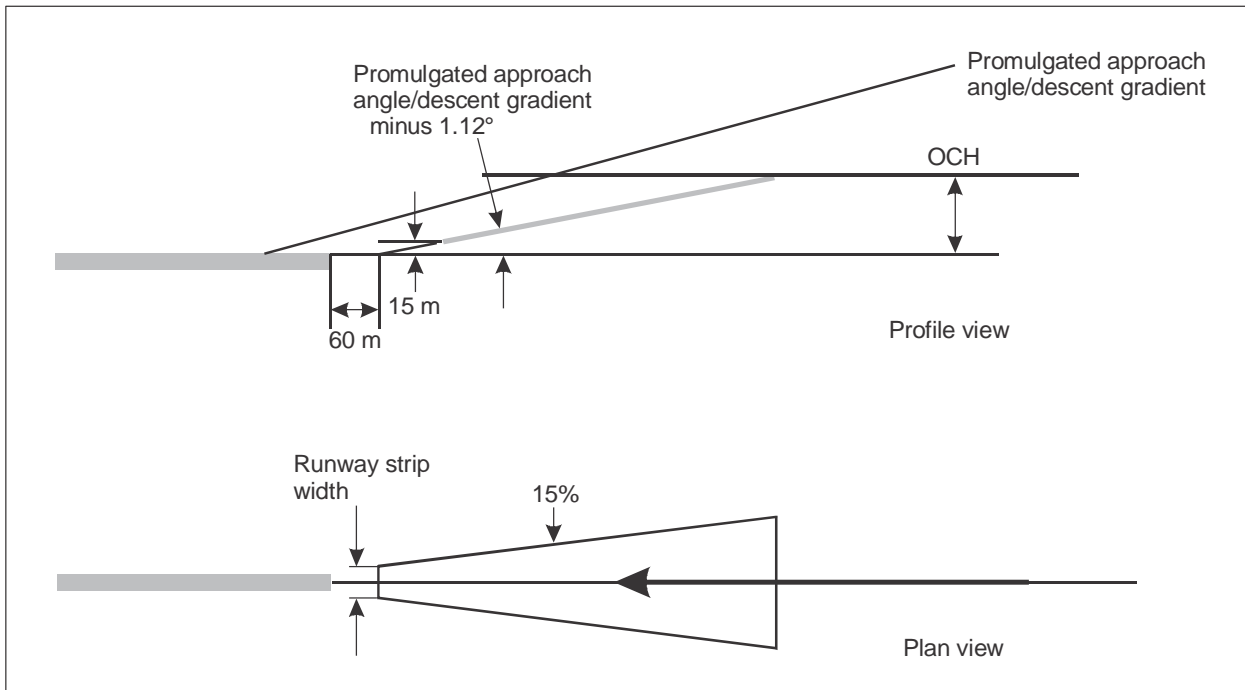

Figure I-4-5-6 b). Visual segment surface other approach procedures normal straight-in approach

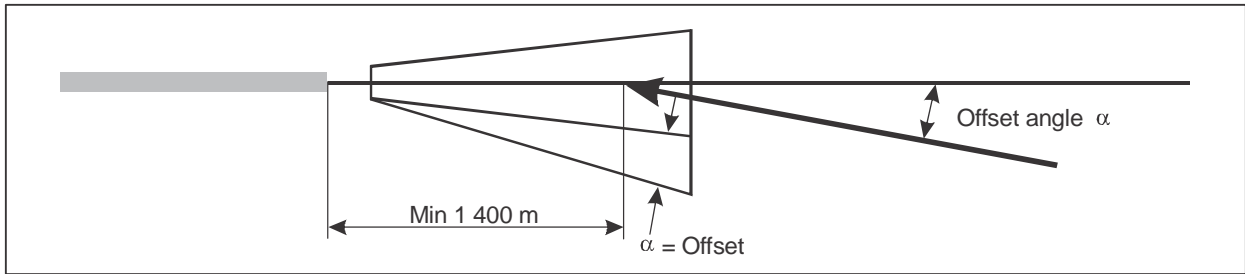

Figure I-4-5-7. Plan view visual segment surface offset final approach with runway centre line crossing

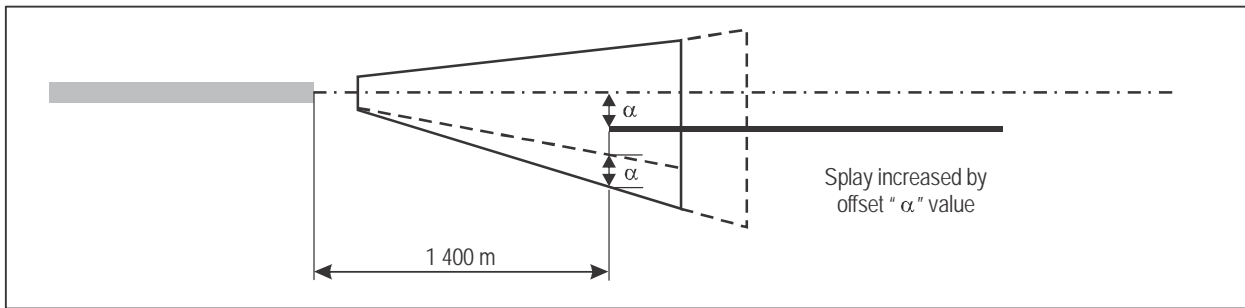

Figure I-4-5-8. Plan view visual segment surface offset final approach parallel to the runway centre line

Appendix A to Chapter 5

CALCULATIONS FOR OCA/H IN NON-ALIGNED STRAIGHT-IN APPROACHES

The values shown in Table I-4-5-2 in Chapter 5 are based on the following calculations:

$$\text{Minimum OCH} = 15 \text{ m} + \text{Total distance} \times \text{descent gradient}$$

$$\text{Total distance} = d_{\text{intercept}} + d_{\text{Add}} + d_{\text{Turn}}$$

where:

$$\text{Minimum intercept distance } (d_{\text{intercept}}) = 1\,400 \text{ m}$$

$$\text{Additional flight time distance } (d_{\text{Add}}) = \text{TAS}_{\text{Cat}} * 5/3\,600$$

TAS_{Cat} = TAS corresponding to the maximum final approach IAS for each aircraft category + 19 km/h (10 kt) tailwind, based on a 600 m (2 000 ft) aerodrome elevation.

Additional flight time before crossing centreline = 5 seconds

$$\text{Turn distance } (d_{\text{Turn}}) = r_{\text{Cat}} * \tan(\theta_{\text{max}}/2)$$

r_{Cat} = Radius of turn calculated for TAS_{Cat}

Maximum turn angle (θ_{max}) = 15 degrees (for $5 < \theta \leq 15$) or 30 degrees (for $15 < \theta \leq 30$)

Appendix B to Chapter 5

NON-PRECISION APPROACHES: STEEP ANGLE APPROACHES

1. INTRODUCTION

1.1 Following changes in the PANS-OPS criteria (e.g.: maximum descent gradient changed from 6.5 per cent to 6.1 per cent for Cat C, D, E) some existing non-precision approach procedures at aerodromes with an obstacle rich environment cannot comply with the maximum descent gradients of the final segment.

1.2 Steep angle approach procedures do not meet PANS-OPS criteria. Such non-standard procedures should only be published after careful consideration that at least includes an aeronautical study and a special approval by the appropriate State authority. They should only be considered:

- a) if there is a significant operational need;
- b) for obstacle clearance purposes and not as a means to introduce noise abatement procedures; and
- c) if it is not possible to provide a vertical guidance (e.g.: localizer-only procedure to be used when the glide-path of a non-standard ILS procedure is out of service).

2. PROCEDURE DESIGN CONSIDERATIONS

Procedure design considerations should at least include:

- a) an addition to the OCA/H as a function of the descent gradient; and
- b) a warning on the chart indicating that the descent gradient does not meet standard criteria.

The following method, implemented by one State, is given as an example:

- a) add 17 ft (Cat A, B) or 25 ft (Cat C, D, E) to the OCH, for each per cent above the maximum descent gradient value of the associated category;
- b) choose the greater of:
 - 1) OCH obtained in a);
 - 2) OCH of the circling associated to the runway; and
- c) add a warning on the approach chart: “descent gradient greater than...”.

3. AERONAUTICAL STUDY

The Aeronautical Study required before implementation of steep angle approach procedures should take into account all the circumstances surrounding the approach and identify risk assessments which have been considered. In this study consideration should be given to at least the following items:

- a) minimum drag configuration;
 - b) effect of wind shear; maximum tail wind;
 - c) control laws;
 - d) handling characteristics;
 - e) minimum power for anti-icing;
 - f) GPWS modifications;
 - g) use of flight director/autopilot;
 - h) engine spin-up time;
 - i) V_{at} increase for handling considerations;
 - j) weather minima;
 - k) visual aids;
 - l) crew qualifications; and
 - m) aircraft certification requirements.
-

Chapter 6

MISSED APPROACH SEGMENT

6.1 GENERAL

6.1.1 Requirements

6.1.1.1 A missed approach procedure shall be established for each instrument approach and shall specify a point where the procedure begins and a point where it ends. The missed approach procedure is initiated:

- a) at the decision altitude height (DA/H) in precision approach procedures or approach with vertical guidance (APV); or
- b) at the missed approach point (MAPt) in non-precision approach procedures.

6.1.1.2 The missed approach procedure shall terminate at an altitude/height sufficient to permit:

- a) initiation of another approach; or
- b) return to a designated holding pattern; or
- c) resumption of en-route flight.

Note.— This chapter contains general criteria which apply to all types of instrument landing procedures, as well as criteria specific to non-precision procedures. For the details regarding precision approaches and approaches with vertical guidance, see the applicable chapters.

6.1.2 Phases of missed approach segment

In principle the missed approach segment starts at the MAPt and includes the following three phases (see Figure I-4-6-4):

- a) initial phase — begins at the earliest MAPt, and extends until the Start of Climb (SOC);
- b) intermediate phase — extends from the SOC to the point where 50 m (164 ft) (Cat H, 40 m (132 ft)) obstacle clearance is first obtained and can be maintained; and
- c) final phase — extends to the point at which a new approach, holding or return to en-route flight is initiated. Turns may be carried out during this phase.

6.1.3 Types of missed approach

There are two types of missed approach:

- a) straight missed approach (includes turns less than or equal to 15 degrees); and
- b) turning missed approach.

6.1.4 Missed approach area

The area considered for the missed approach shall start at the earliest MAPt tolerance, with a width equal to that of the final approach segment at that point. The subsequent size and shape of the area depends on the missed approach procedure, including the point at which a turn is initiated, if applicable, and the extent of the turn.

6.1.5 Missed approach point (MAPt)

6.1.5.1 *General.* A missed approach begins at the missed approach point (MAPt) and only applies to non-precision approaches. For non-precision approaches, the MAPt shall be defined as follows:

- a) *procedures without a FAF* — by a navigation facility or fix; and
- b) *procedures with a FAF* — the MAPt shall be defined by one of the following three cases:
 - 1) by timing over the distance from the nominal FAF to the nominal MAPt, where the MAPt is not defined by a facility or fix; or
 - 2) by a navigation facility or fix at the MAPt, in which case the procedure must be annotated “timing not authorized for defining the MAPt”; or
 - 3) by both timing over the distance from the nominal FAF to the nominal MAPt, as well as a facility or fix at the missed approach point. In this case a single OCA/H, which shall be the higher of the OCA/H for the specified distance and the OCA/H for the facility or fix, shall be published. However, when an operational advantage can be achieved, both may be published.

6.1.5.2 *Location of MAPt.* The optimum location of the MAPt is the runway threshold. Where necessary, the MAPt may be moved closer to the FAF provided that the OCA/H is not lower than the altitude/height at the MAPt on a nominal 5.2 per cent (3°) descent gradient or the promulgated descent gradient if steeper. An increase in OCA/H may be required to meet this condition.

6.1.5.3 *Determining earliest and latest MAPt for an MAPt determined by distance.* When the MAPt is determined by timing over the distance from the FAF, the total MAPt tolerance (Y) may be determined by taking the values from Table I-4-6-1 and applying them as shown in Figure I-4-6-3. For the refined calculations see the appendix to this chapter.

6.1.6 Calculating start of climb (SOC)

6.1.6.1 There are two methods for calculating SOC. The method used depends on whether:

- a) the MAPt is defined by a navigation facility or fix; or
- b) the MAPt is defined by a specified distance from the FAF.

6.1.6.2 *Determining SOC with an MAPt defined by a navigation facility or fix.* When the MAPt is defined by a navigation facility or fix (see Figure I-4-6-1), SOC is determined by the sum of :

- a) the MAPt tolerance; and
- b) the transitional distance (X).

6.1.6.2.1 *MAPt tolerance when MAPt is defined by a navigation facility or fix.* When the MAPt is defined by a navigation facility or fix (see Figure I-4-6-1), the MAPt longitudinal tolerance is defined by the sum of :

- a) the full tolerance of the facility/fix; plus
- b) a distance (d), allowing for pilot reaction time. This value corresponds to 3 seconds of flight at the maximum final approach speed for the specific aircraft category, plus a tail wind factor of 19 km/h (10 kt). Example values of d for each aircraft category (calculated for a 600 m (2 000 ft) aerodrome elevation) appear in Table I-4-6-3.

If the MAPt is defined by overheading a navigation facility (VOR, NDB or 75 MHz marker beacon) the fix tolerance is 0 km (NM).

6.1.6.2.2 *Transitional distance with an MAPt defined by a navigation facility or fix.* Transitional distance (X) with an MAPt defined by a navigation facility or fix is based on 15 seconds (Cat H, 5 seconds) of flight at a TAS based on the highest final approach speed for each aircraft category (see Tables I-4-1-1 and I-4-1-2 of Chapter 1), at the aerodrome elevation with a temperature of ISA + 15°C and a tailwind of 19 km/h (10 kt). These values are applied as shown in Figure I-4-6-1.

6.1.6.3 *Determining SOC with an MAPt defined by a distance from the FAF (simplified method).* For determining SOC with an MAPt defined by a distance from the FAF, a simplified method can be used as an estimate for altitudes up to 4 000 m (13 000 ft), see Figure I-4-6-2. In this case SOC is determined by the sum of:

- a) the distance from the nominal FAF to the nominal MAPt; and
- b) transitional distance (X).

6.1.6.3.1 *Transitional distance with an MAPt defined by distance.* Transitional distance with an MAPt defined by distance is based on 15 seconds (Cat H, 5 seconds) of flight at the appropriate TAS, at the aerodrome elevation with a temperature of ISA + 15°C and a tailwind of 19 km/h (10 kt). See Table I-4-6-2 for computation of transitional distance (X).

6.1.6.4 *Determining SOC with an MAPt defined by a distance from the FAF (refined method).* The refined method shall be used for altitudes over 4 000 m (13 000 ft), and may give an operational advantage in some conditions under 4 000 m (13 000 ft). This method is shown in the appendix.

6.2 CLIMB GRADIENT AND MOC

6.2.1 Initial phase

6.2.1.1 The initial phase begins at the earliest missed approach point (MAPt) and ends at the start of climb point (SOC). The manoeuvre during this phase requires the concentrated attention of the pilot, especially when establishing the climb and the changes in configuration, and it is assumed that guidance equipment is not utilized during these manoeuvres. No turns may be specified during this phase.

6.2.1.2 *Climb gradient in the initial phase.* In the initial phase the flight track is horizontal.

6.2.1.3 *Obstacle clearance in the initial phase.* In the initial missed approach area, the minimum obstacle clearance shall be the same as for the last part of the final approach area except where the extension of the intermediate missed approach surface backwards towards the missed approach point requires less clearance. (See Figures I-4-6-4 and I-4-6-5.)

6.2.2 Intermediate phase

6.2.2.1 The intermediate phase begins at the SOC. The climb is continued at stabilized speeds up to the first point where 50 m (164 ft) (Cat H, 40 m (132 ft)) obstacle clearance is obtained and can be maintained. In the construction of this phase it is assumed that advantage may be taken of available navigation guidance. During the intermediate phase, the missed approach track may be changed from that of the initial phase by a maximum of 15°.

6.2.2.2 *Climb gradient in the intermediate phase.* The nominal climb gradient (tan Z) of the missed approach surface is 2.5 per cent (Cat H 4.2 per cent). A gradient of 2 per cent may be used if the necessary survey and safeguarding can be provided. Additional climb gradients of 3, 4 or 5 per cent may also be specified. These may be used by aircraft whose climb performance permits the operational advantage of the lower OCA/H associated with these gradients, with the approval of the competent authority.

Note.— In case of non-precision approach, any intermediate values (e.g. 3.4 per cent) between 2 and 5 per cent may be considered.

6.2.2.3 *Obstacle clearance in the intermediate phase*

6.2.2.3.1 In the intermediate missed approach phase, the minimum obstacle clearance shall be 30 m (98 ft) in the primary area, and in the secondary area the minimum obstacle clearance shall be 30 m (98 ft) at the inner edge, reducing linearly to zero at the outer edge. See Section 2, Chapter 1, 1.3, “Obstacle clearance”.

6.2.2.3.2 The OCA/H for the nominal 2.5 per cent must always be published on the instrument approach chart. If additional gradients are specified in the construction of the missed approach procedure, they and their associated OCA/H values must be published as alternative options.

Note.— MOC may be obtained by increasing the OCA/H or by a longitudinal adjustment of the MAPt or both.

6.2.3 Final phase

The final phase begins at the point where 50 m (164 ft) (Cat H, 40 m (132 ft)) obstacle clearance is first obtained and can be maintained. It ends at the point at which a new approach, holding or return to en-route flight is initiated. Turns may be carried out during this phase.

6.2.3.1 *Climb gradient in the final phase.* The criteria of the intermediate phase apply.

6.2.3.2 *Obstacle clearance in the final phase*

6.2.3.2.1 In the final missed approach phase of a straight missed approach the minimum obstacle clearance shall be 50 m (164 ft) (Cat H, 40 m (132 ft)) in the primary area, reducing linearly to zero at the outer edge of the secondary area. See Figure I-4-6-4.

6.2.3.2.2 Turning missed approaches have specific criteria for MOC and for the arrangement and extent of secondary areas (see 6.4, “Turning missed approach”).

Note.— MOC may be obtained by increasing the OCA/H or by a longitudinal adjustment of the MAPt or both. In addition, obstacles may be excluded from consideration by defining a turn.

6.3 STRAIGHT MISSED APPROACH

6.3.1 This section contains the criteria for a straight missed approach. It includes turns less than or equal to 15 degrees.

6.3.2 Area for straight missed approach

6.3.2.1 The straight missed approach area has a width at its origin equal to that of the final approach area at that point. Thereafter it splays at an angle:

- a) determined by the accuracy of the tracking navigation aid used (10.3° for NDB, 7.8° for VOR) (see Figure I-4-6-6); or
- b) with a divergence of 15° where no reference to a navigation aid is available.

6.3.2.2 The area extends a sufficient distance to ensure that an aircraft executing a missed approach has reached an altitude at which obstacle clearances for subsequent procedures (such as for en-route or holding) can be observed. The initial phase of the missed approach surface is horizontal, and is based on the lowest assumed flight path at the OCA/H. The start of climb (SOC) for the intermediate and final phases originates immediately beyond the transitional distance (see 6.1.6.2.2, “Transitional distance with an MAPt defined by a navigation facility or fix” and 6.1.6.3.1, “Transitional distance with an MAPt defined by distance”). The intermediate and final phases ascend uniformly with the gradient of the missed approach surface, as specified in 6.2, “Climb gradient and MOC”.

6.3.2.3 *Additional track guidance.* An operational advantage may be obtained during the development of the missed approach procedure by using suitably located facilities to reduce the dimensions of the final phase. In this case the boundaries of the final phase are continued until they intersect the appropriate boundaries for the facility provided:

- a) for a VOR ± 1.9 km (± 1.0 NM) with a splay (towards the MAPt) of 7.8°; and
- b) for an NDB ± 2.3 km (± 1.25 NM) with a splay of 10.3°.

Figures I-4-6-7 and I-4-6-8 show missed approach areas both with and without additional track guidance.

6.3.2.4 *Continuous track guidance.* When the track guidance for missed approach is a continuation of guidance from the facility used on the final approach, the missed approach area is a continuation of the area(s) defined for that facility. See Figure I-4-6-9.

6.3.3 Primary and secondary area

The general criteria apply.

6.3.4 Alignment

Wherever practical the missed approach track should be a continuation of the final approach track. Missed approaches involving turns are permitted (see 6.4, “Turning missed approach”), but should only be employed when an operational advantage may be obtained.

6.3.5 Obstacle clearance for the straight missed approach

The general criteria apply as stated in 6.2, “Climb gradient and MOC”.

6.4 TURNING MISSED APPROACH

6.4.1 This section contains the criteria for a turning missed approach for turns of more than 15 degrees. For turns less than or equal to 15 degrees, the criteria for a straight missed approach apply. See 6.3, “Straight missed approach”, above. Turns may be defined as occurring at:

- a) an altitude/height;
- b) a fix or facility; or
- c) the MAPt.

6.4.2 General

If a turn from the final approach track is specified, turning missed approach areas must be constructed. The criteria in 6.3, “Straight missed approach” above remain in effect until the following:

- a) the turning point (TP) for turns specified by altitude/height (see 6.4.5, “Turn initiated at a designated altitude/height”); and
- b) the earliest TP for turns at a designated TP (see 6.4.6, “Turn initiated at a designated turning point”). To obtain the minimum OCA/H it may be necessary to adjust the designated turn altitude or turning point (TP). The number of variables is such that this may involve a trial and error process.

Note.— All calculations in this chapter are made for the 2.5 per cent nominal gradient. See 6.2.2 for use of gradients other than 2.5 per cent.

6.4.3 Turn parameters

This section shows the parameters on which the turn areas are based, together with the variables which represent them in the drawings.

- a) *Altitude*: Aerodrome altitude plus 300 m (1 000 ft) or the defined turn altitude.
- b) *Temperature*: ISA + 15°C corresponding to a) above.

- c) *Indicated airspeed (IAS)*: The speed for final missed approach is shown in Tables I-4-1-1 and I-4-1-2 of Chapter 1. However, where operationally required to avoid obstacles, reduced speeds as slow as the IAS for intermediate missed approach may be used, provided the procedure is annotated “Missed approach turn limited to _____ km/h (kt) IAS maximum.”
- d) *True airspeed*: The IAS in c) above adjusted for altitude a) and temperature b).
- e) *Wind*: Maximum 95 per cent probability wind on an omnidirectional basis, where statistical wind data is available. Where no wind data is available, an omnidirectional 56 km/h (30 kt) wind should be used.
- f) *Average achieved bank angle*: 15°.
- g) *Fix tolerance*: As appropriate for the type of fix. See Section 1, Chapter 2, “Terminal area fixes”.
- h) *Flight technical tolerances*:
 - 1) c = a distance equivalent to 6 seconds of flight (3-second pilot reaction and 3-second bank establishing time) at the final missed approach speed (for maximum published missed approach speed) plus 56 km/h (30 kt) tailwind; and
 - 2) see also the turning parameters shown as examples in Tables I-4-6-5 and I-4-6-6.
- i) d_o = Distance to an obstacle.
- j) d_z = Shortest distance to an obstacle or datum measured from SOC parallel to the straight missed approach track.
- k) O_i = Obstacle (subscript indicates the specific obstacle).
- l) $\tan Z$ = Tangent of the angle of the missed approach surface with the horizontal plane.
- m) R = Rate of turn.
- n) r = Turn radius.
- o) E = Wind effect.

6.4.4 Secondary areas

6.4.4.1 In the turn area, the secondary area always applies on the outer side of the turn, as a continuation of the straight missed approach secondary area (see Figures I-4-6-13 to I-4-6-19 for a turn designated at a turn point). The secondary areas resume as soon as the aircraft has track guidance.

6.4.4.2 *Additional track guidance*. After the turn an operational advantage may be obtained during the development of the missed approach procedure, by using suitably located facilities to reduce the dimensions of the final missed approach area. Examples of typical turning missed approach areas with additional track guidance are shown in Figures I-4-6-15 and I-4-6-19.

6.4.5 Turn initiated at a designated altitude/height

6.4.5.1 General

A turn is prescribed upon reaching a specified altitude to cope with two kinds of penalizing obstacles:

- a) an obstacle located in the direction of the straight missed approach and which must be avoided; and
- b) an obstacle located abeam the straight missed approach track and which must be overflown after the turn with the appropriate margin.

A turning missed approach at a designated altitude requires a climb to a specified altitude/height before initiating a turn to a specified heading or towards a fix/facility.

6.4.5.2 Areas

6.4.5.2.1 Turn initiation area

6.4.5.2.1.1 The point where the designated altitude/height is reached is not fixed. It depends on the climb performance of the aircraft and the point from which the missed approach is initiated. The aircraft may reach the designated turn altitude/height:

- a) as early as the earliest MAPt when the procedure prohibits turning before the MAPt or as early as the earliest FAF when no restrictions are provided; and
- b) after a climb using the minimum required gradient from the SOC to the point where it reaches the specified altitude height. This point is called the Turn Point (TP).

6.4.5.2.1.2 Procedure design should take both extremes into account. Therefore the area where the aircraft can initiate its turn is bounded by:

- a) the distance from the earliest MAPt or earliest FAF to the TP; and
- b) the edges of the secondary areas of the initial and intermediate phases.

This area is called the turn initiation area. The line which marks the end of the turn initiation area is defined by KK (see Figures I-4-6-11 and I-4-6-12).

6.4.5.2.2 Turn area

The turn area's boundaries are constructed to protect aircraft in the two extreme cases described above:

- a) *inner boundary construction:*
 - 1) for turns less than 75 degrees, the inner boundary originates at the inner edge of the earliest MAPt (Figure I-4-6-11) and splays at an angle of 15 degrees relative to the nominal track after the turn; and
 - 2) for turns more than 75 degrees, the inner boundary originates at the outer edge of the earliest MAPt (Figure I-4-6-12) and splays at an angle of 15 degrees relative to the nominal track after the turn; and

b) *outer boundary construction:*

- 1) on the outer edge of the turn initiation area, add a tolerance to account for pilot reaction time (c: a distance equivalent to 6 seconds of flight (See 6.4.3, “Turn parameters”). This establishes point A; and
- 2) from point A, construct the outer boundary as described in Section 2, Chapter 3, “Turn area construction”.

6.4.5.3 *Obstacle clearance for turns at a designated altitude*

- a) *Obstacle clearance in the turn initiation area.* The straight missed approach obstacle clearance criteria apply up to the TP. This allows the calculation of OCA/H for final approach and straight missed approach segments (OCA/H_{fm}) (see 6.3.5, “Obstacle clearance for the straight missed approach”). An additional obstacle assessment must be made to assure that the obstacle elevation/height in the turn initiation area shall be less than

$$\text{TNA/H} - 50 \text{ m (164 ft)}$$

$$\text{(Cat H, TNA/H} - 40 \text{ m (132 ft))}$$

- b) *Obstacle clearance in the turn area.* Obstacle elevation/height in the turn area shall be less than:

$$\text{TNA/H} + d_o \tan Z - \text{MOC}$$

where: d_o is measured from the obstacle to the nearest point on the turn initiation area boundary; and

MOC is 50 m (164 ft) (Cat H, 40 m (132 ft)) reducing linearly to zero at the outer edge of the secondary areas, if any.

6.4.5.4 *Establishment of turn altitude/height*

The choice of the turn altitude/height (TNA/H) and associated turn point (TP) is an iterative process. The TP must be located so that the obstacle clearance criteria in both the turn initiation area and turn area are satisfied. Once SOC and OCA/H_{fm} are determined, turn altitude/height (TNA/H) may be computed from the following relationship:

$$\text{TNA/H} = \text{OCA/H}_{\text{fm}} + d_z \tan Z$$

where d_z is the horizontal distance from SOC to the TP.

If the latest TP has to be located at or before the SOC calculated for the final and straight missed approach, then the MAPt shall be moved back and, if necessary, the OCA/H increased. (See 6.1.5.1.)

6.4.5.5 *Turn altitude/height adjustments*

If the criteria specified in 6.4.5.3, “Obstacle clearance for turns at a designated altitude” cannot be met, the turn altitude/height shall be adjusted. This can be done in three ways:

- a) adjust TNA/H without changing OCA/H. This means that the latest TP will be moved and the areas redrawn accordingly;

- b) move SOC back to increase d_z . This means that the MAPt and consequently earliest TP will be moved and the turn areas extended accordingly; and
- c) increase OCA/H.

6.4.5.6 Safeguarding of early turns

If the procedure does not prohibit turns before the MAPt, then an additional area outside the final approach area must be considered (see Figure I-4-6-14). In this area obstacle elevation shall be less than:

$$\text{TNA/H} + d_o \tan Z - 50 \text{ m (164 ft)}$$

$$\text{(Cat H, TNA/H} + d_o \tan Z - 40 \text{ m (132 ft))}$$

where d_o is measured from the obstacle to the nearest point on the edge of the final approach area. If this criterion cannot be met, then the procedure must prohibit turns before the MAPt and a note must be added on the profile view of the approach chart.

6.4.6 Turn initiated at a designated turning point

6.4.6.1 *General.* A designated TP shall be defined by a fix (see Section 2, Chapter 2, 2.3 and 2.4), or by a limiting radial, bearing or DME distance (see Section 2, Chapter 2, 2.6.5). It is chosen to allow the aircraft to avoid an obstacle straight ahead. The straight missed approach criteria apply up to the earliest TP. This allows the calculation of OCA/H for final and straight missed approach (OCA/H_{fm}) (see 6.2 “Climb gradient and MOC”). SOC is then determined.

6.4.6.2 *Turning point tolerance area.* The length of the TP tolerance area is determined by:

- a) the limits of the fix tolerance area, plus;
- b) an additional distance c (pilot reaction and bank establishing time) equivalent to 6 seconds of flight at final missed approach (or maximum published missed approach) speed plus 56 km/h (30 kt) tailwind (see Figure I-4-6-15). Some example values of c are shown in Tables I-4-6-5 and I-4-6-6.

If the TP is defined by overheading a facility (e.g. VOR, NDB) the TP fix tolerance can be taken as ± 0.9 km (± 0.5 NM) up to a height above the facility of:

- i) 750 m (2 500 ft) for a VOR (with a cone angle of 50°); and
- ii) 1 100 m (3 600 ft) for an NDB.

6.4.6.3 Construction of the turn area

6.4.6.3.1 Turns are executed in the final missed approach area. This area begins at point A, which is located at the latest limit of the TP tolerance area (defined above). Its sides begin at the edges of the straight missed approach area.

6.4.6.3.2 TP defined by a fix or by a limiting radial, bearing or DME distance.

a) *Outer boundary:*

- 1) On the outside edge of the missed approach area, determine point A (see Figure I-4-6-15).

- 2) From point A, construct the outer boundary as described in Section 2, Chapter 3, “Turn area construction”.
- b) *Inner boundary:*
- 1) On the inner edge of the missed approach area, at the earliest TP tolerance, determine point K.
 - 2) From point K, draw a line splayed outward at an angle of 15° from the nominal track after the turn.
- c) *Particular cases:* for particular cases (turns more than 90°, return to the FAF), draw the area after that turn as shown on Figures I-4-6-16, I-4-6-17 and I-4-6-18.

6.4.6.3.3 *TP marked by a facility (NDB or VOR).* When the turning point is marked by a facility (NDB or VOR) the area is constructed as follows.

- a) *Inner boundary:* the boundary which is associated with tracking outbound from this facility after the turn.
- b) *Outer boundary:* in order to accommodate the overshoot when turning over a navaid, the boundary on the outer side of the turn must be widened as follows:
- 1) determine the latest TP tolerance (point A);
 - 2) from point A, construct the outer boundary (see Section 2, Chapter 3, “Turn area construction”) up to the point where its tangent becomes parallel to the nominal track after the turn; and
 - 3) from this point the area boundary remains parallel to the nominal track until it intersects the area associated with the navaid (see Figure I-4-6-19).

6.4.6.4 *Obstacle clearance in the turn area*

Obstacle elevation in the turn area shall be less than:

$$\text{OCA}/H_{\text{fm}} + d_o \tan z - \text{MOC}$$

where: $d_o = d_z +$ shortest distance from obstacle to line K-K,

$d_z =$ horizontal distance from SOC to earliest TP (line K-K)

and MOC is 50 m (164 ft) (Cat H, 40 m (132 ft)) for turns more than 15° reducing linearly to zero at the outer edge of the secondary areas, if any.

6.4.7 Turn specified at the MAPt

Where the turn is specified at the MAPt, which means that the pilot is supposed to establish the aeroplane on a climbing path and then to turn, the OCA/H will be taken as the turn altitude/height and the turn initiation area will extend from the earliest MAPt to the SOC (see Figures I-4-6-10 and I-4-6-20).

6.5 PROMULGATION

6.5.1 If safeguarding of early turns is not provided a note must be added on the profile view of the approach chart: “No turn before MAPt”.

6.5.2 The OCA/H for the nominal 2.5 per cent must always be published on the instrument approach chart. If additional gradients are specified in the construction of the missed approach procedure, they and their associated OCA/H values must be published as alternative options.

Table I-4-6-1. Values for Z (Earliest and latest MAPt for MAPt determined by distance from the FAF)

<i>Aircraft category</i>	<i>Distance from nominal MAPt to earliest and latest MAPt</i>
Category A	$\max \{2463; 0.3897D + 1086\}$
Category B	$\max \{2463; 0.2984D + 1408\}$
Category C	$\max \{2463; 0.1907D + 1787\}$
Category D	$\max \{2463; 0.1562D + 1908\}$

Where D = distance from nominal FAF to nominal MAPt (m). The values in the table are SI units (meters).

Table I-4-6-2. Computation of transitional distance

<i>Aircraft category</i>	<i>Transitional distance (X)</i>
Category A	$\max \{0.0875D + 2591; 0.3954D + 1604\}$
Category B	$\max \{0.0681D + 3352; 0.3246D + 1653\}$
Category C	$\max \{0.0567D + 3794; 0.2328D + 1945\}$
Category D	$\max \{0.0495D + 4153; 0.2055D + 2073\}$

Where D = distance from nominal FAF to nominal MAPt (m). The values in the table are in SI units (meters).

Table I-4-6-3. Example: Distance d corresponding to 600 m (2 000 ft) above MSL

<i>Aircraft category</i>	<i>A</i>	<i>B</i>	<i>C</i>	<i>D</i>	<i>E</i>	<i>H</i>
d	0.18 km (0.10 NM)	0.23 km (0.12 NM)	0.28 km (0.15 NM)	0.32 km (0.17 NM)	0.39 km (0.21 NM)	0.16 km (0.09 NM)

Table I-4-6-4. Example: Distance of transitional tolerance

<i>Aircraft category</i>	<i>A</i>	<i>B</i>	<i>C</i>	<i>D</i>	<i>E</i>	<i>H</i>
X (computed at 600 m (2 000 ft) above MSL)	0.89 km (0.48 NM)	1.14 km (0.61 NM)	1.38 km (0.75 NM)	1.60 km (0.86 NM)	1.95 km (1.05 NM)	0.27 km (0.15 NM)

Table I-4-6-5. Examples of the values of the parameters used in the turning missed approach area construction (calculated for 600 m MSL) (for abbreviations, see 6.4.3)

<i>IAS</i> (km/h)	<i>TAS</i> (600 m, ISA + 15) <i>IAS</i> × <i>conversion</i> <i>factor</i> * (km/h)	<i>c</i> 6 seconds $(TAS + 56) \times \frac{6}{3600}$ (km)	<i>R</i> $\frac{542}{TAS}$ (deg/s)	<i>r</i> $\frac{TAS}{62.8R}$ (km)	<i>E</i> $\frac{1.4}{R}$ (km)
205	217	0.46	2.50	1.38	0.56
280	296	0.59	1.83	2.57	0.76
345	364	0.70	1.49	3.89	0.94
400	422	0.80	1.28	5.23	1.09
445	470	0.88	1.15	6.49	1.21
490	518	0.96	1.05	7.85	1.34
510	539	0.99	1.01	8.54	1.39

* For conversion from IAS to TAS, see Part I, Section 2, Chapter 1, Appendix.

Table I-4-6-6. Examples of the values of the parameters used in the turning missed approach area construction (calculated for 2 000 ft MSL) (for abbreviations, see 6.4.3)

<i>IAS</i> (<i>kt</i>)	<i>TAS</i> (2 000 ft, ISA + 15) <i>IAS conversion</i> <i>factor*</i> (<i>kt</i>)	<i>c</i> <i>6 seconds</i> $(TAS + 30) \times \frac{6}{3600}$ (<i>NM</i>)	<i>R</i> 293 <i>TAS</i> (<i>deg/s</i>)	<i>r</i> <i>TAS</i> 62.8 <i>R</i> (<i>NM</i>)	<i>E</i> 0.75 <i>R</i> (<i>NM</i>)
110	116	0.24	2.53	0.73	0.30
150	159	0.32	1.84	1.37	0.41
185	195	0.38	1.50	2.07	0.50
200	211	0.40	1.39	2.42	0.54
240	254	0.47	1.15	3.51	0.65
265	280	0.52	1.05	4.25	0.72
275	291	0.54	1.01	4.60	0.74

* For conversion from IAS to TAS, see Part I, Section 2, Chapter 1, Appendix.

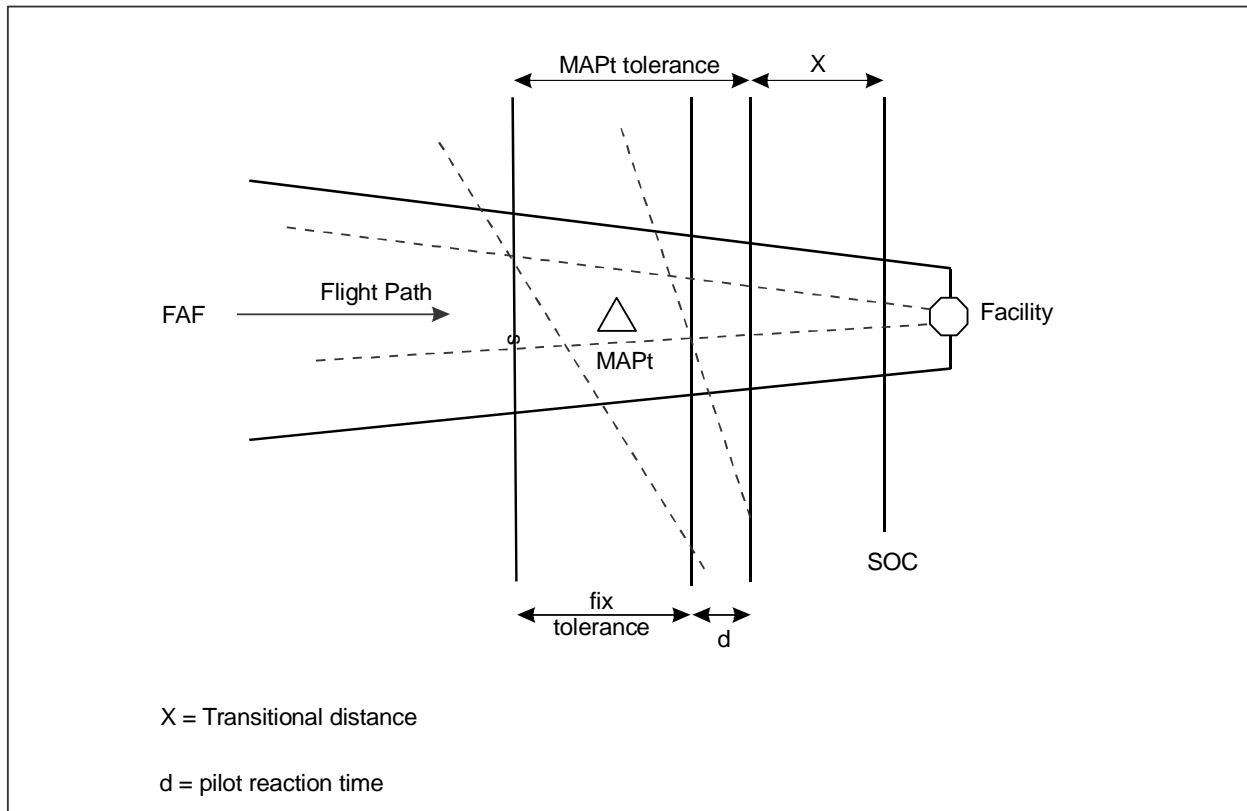

Figure I-4-6-1. Determining SOC with an MAPt defined by a navigation facility or fix

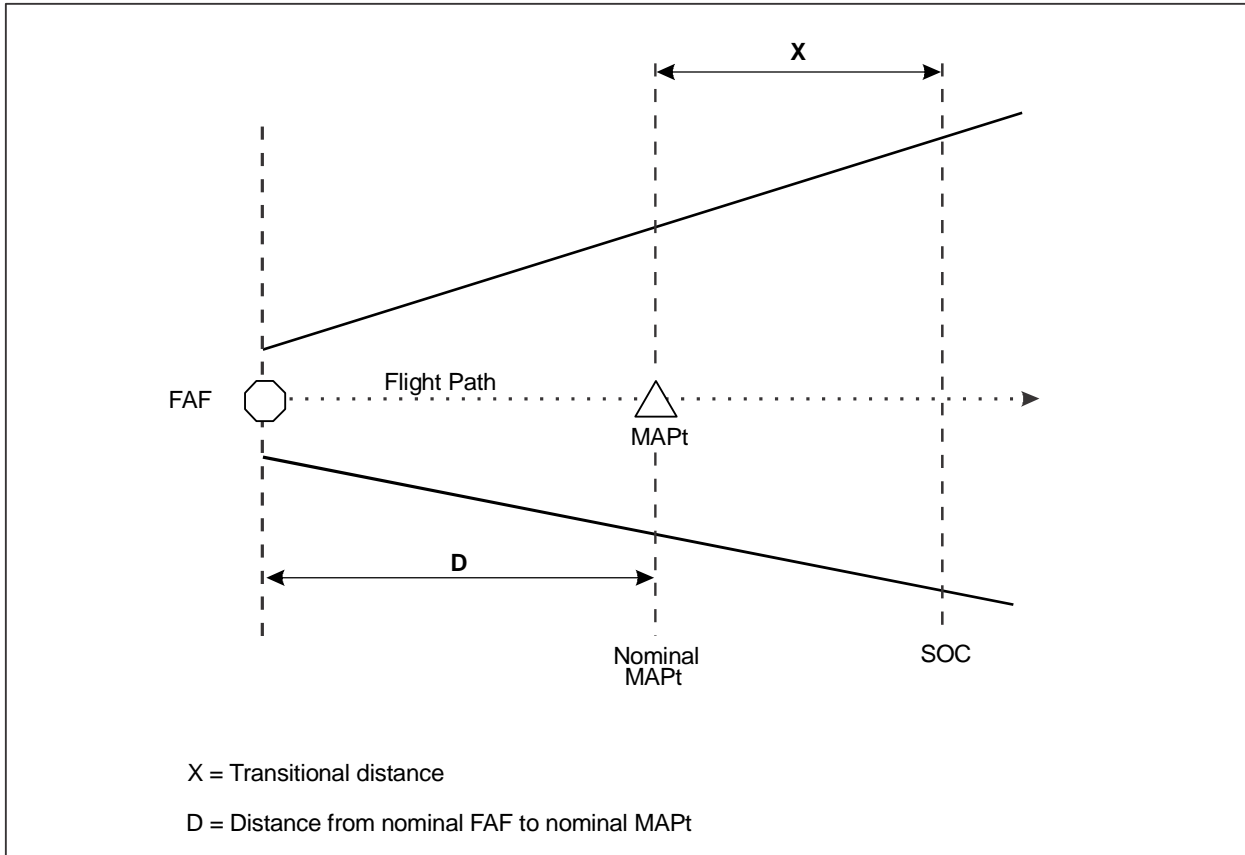

Figure I-4-6-2. Determining SOC with an MAPt defined by a distance from the FAF

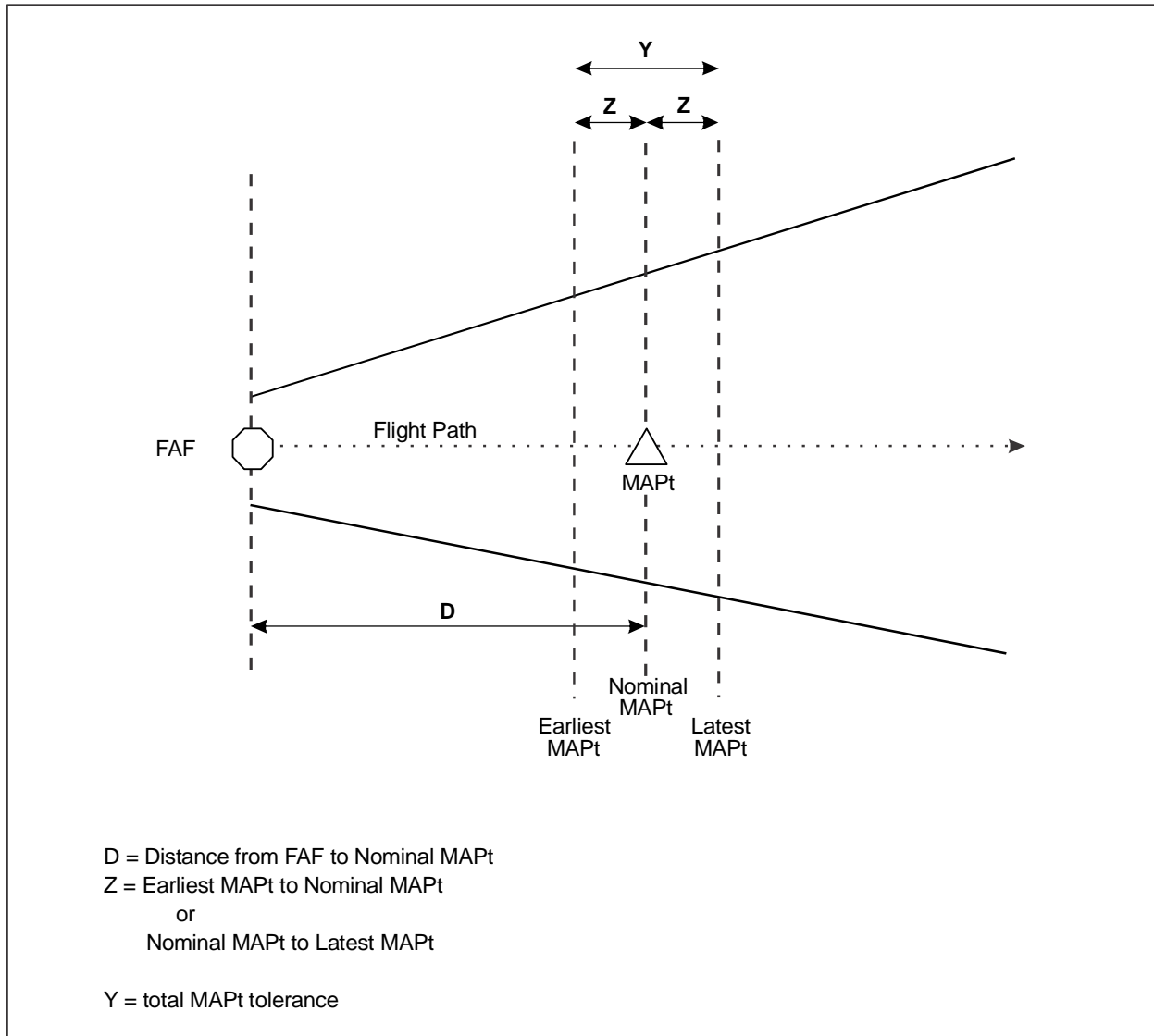

Figure I-4-6-3. Distance from nominal MAPt to earliest and latest MAPt

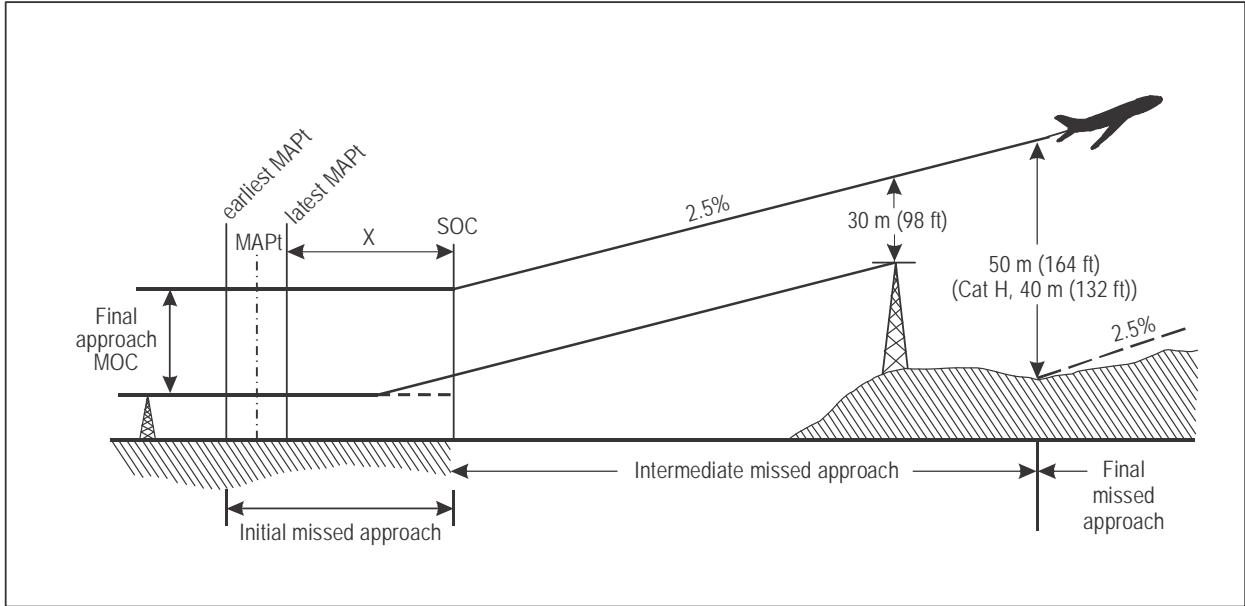

Figure I-4-6-4. Obstacle clearance for final missed approach phase

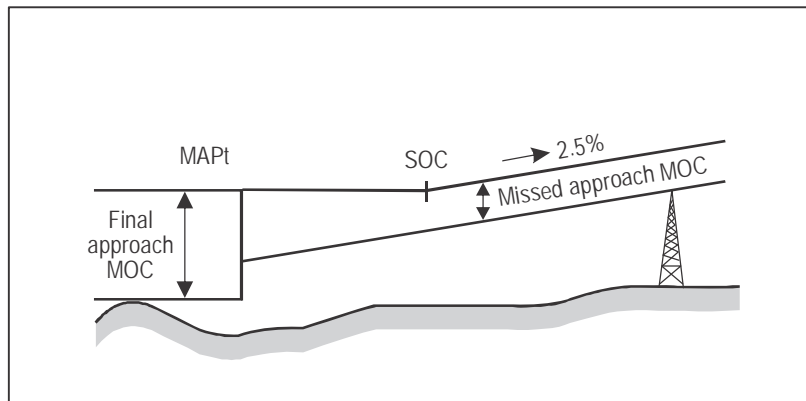

Figure I-4-6-5. Case where the extension of the missed approach surface covers the initial missed approach phase entirely

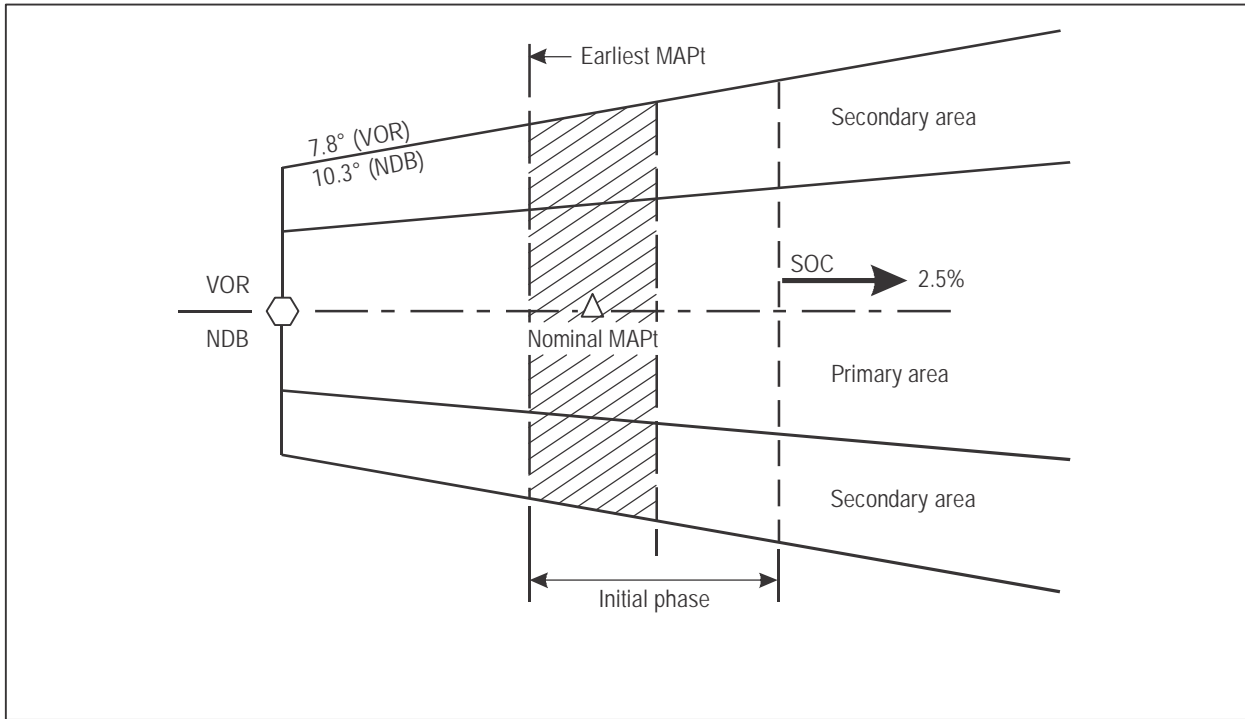

Figure I-4-6-6. Area for straight missed approach

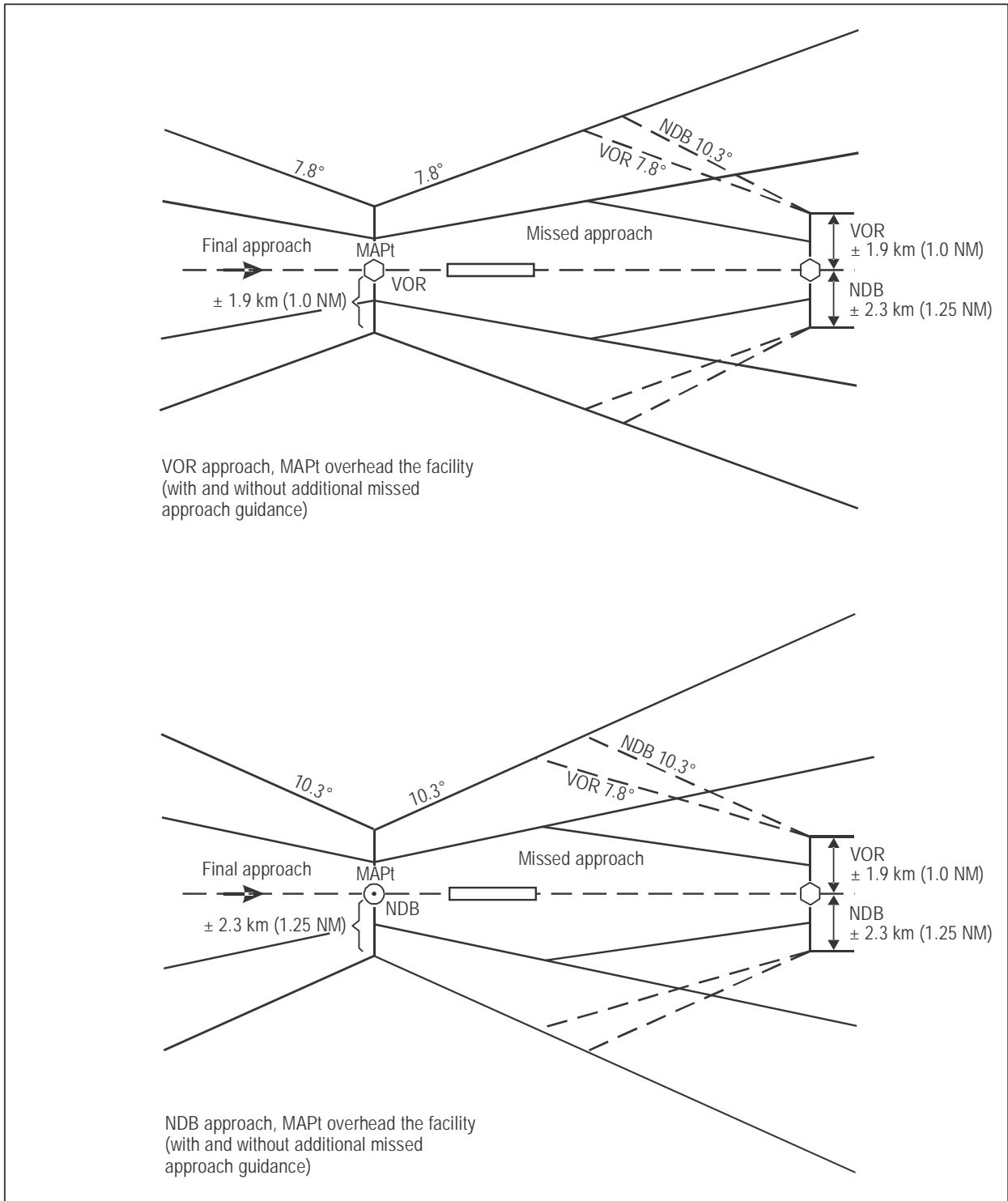

Figure I-4-6-7. Area associated with additional track guidance for MAPt defined by a navigation facility

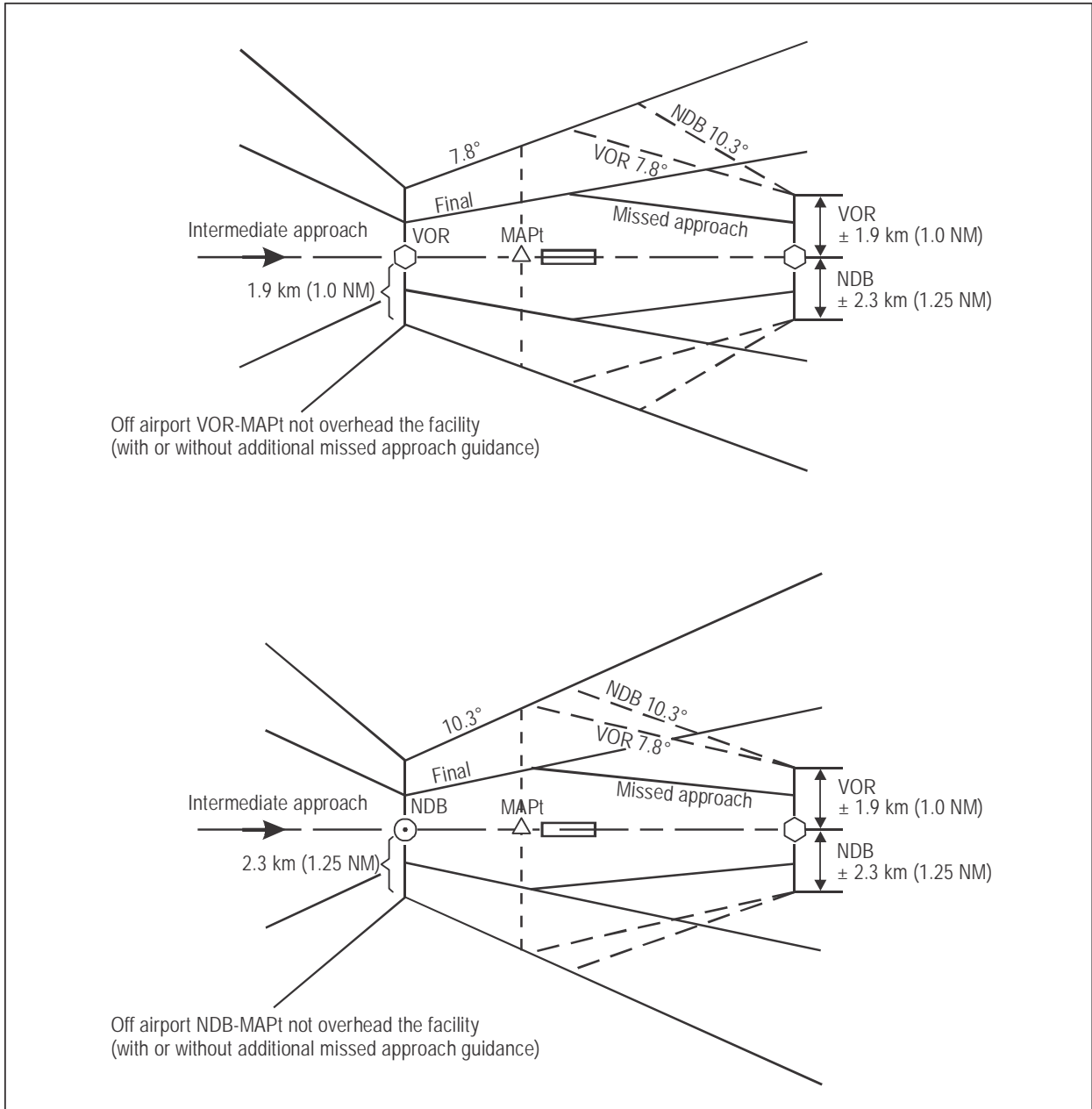

Figure I-4-6-8. Areas associated with additional track guidance for MAPt not at a facility

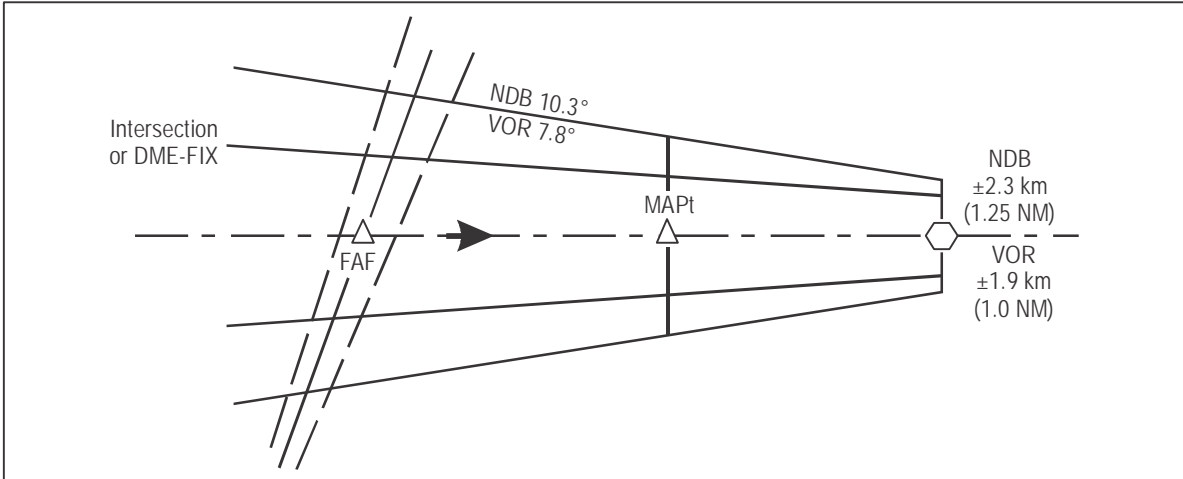

Figure I-4-6-9. Example of area where the track guidance for missed approach is a continuation of guidance from the facility used on the final approach

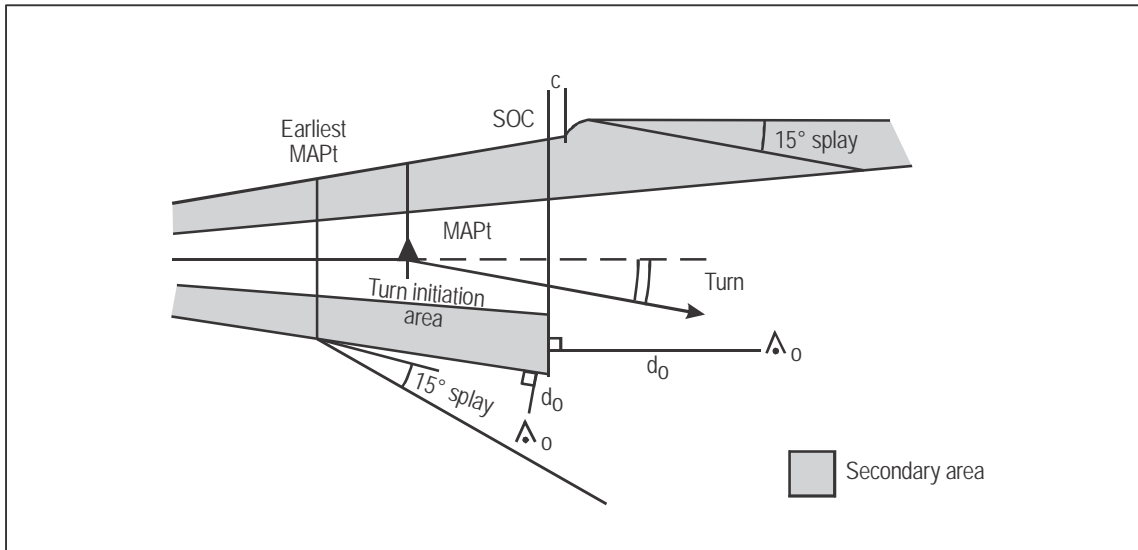

Figure I-4-6-10. Missed approach turn 15° or less at the MAPt

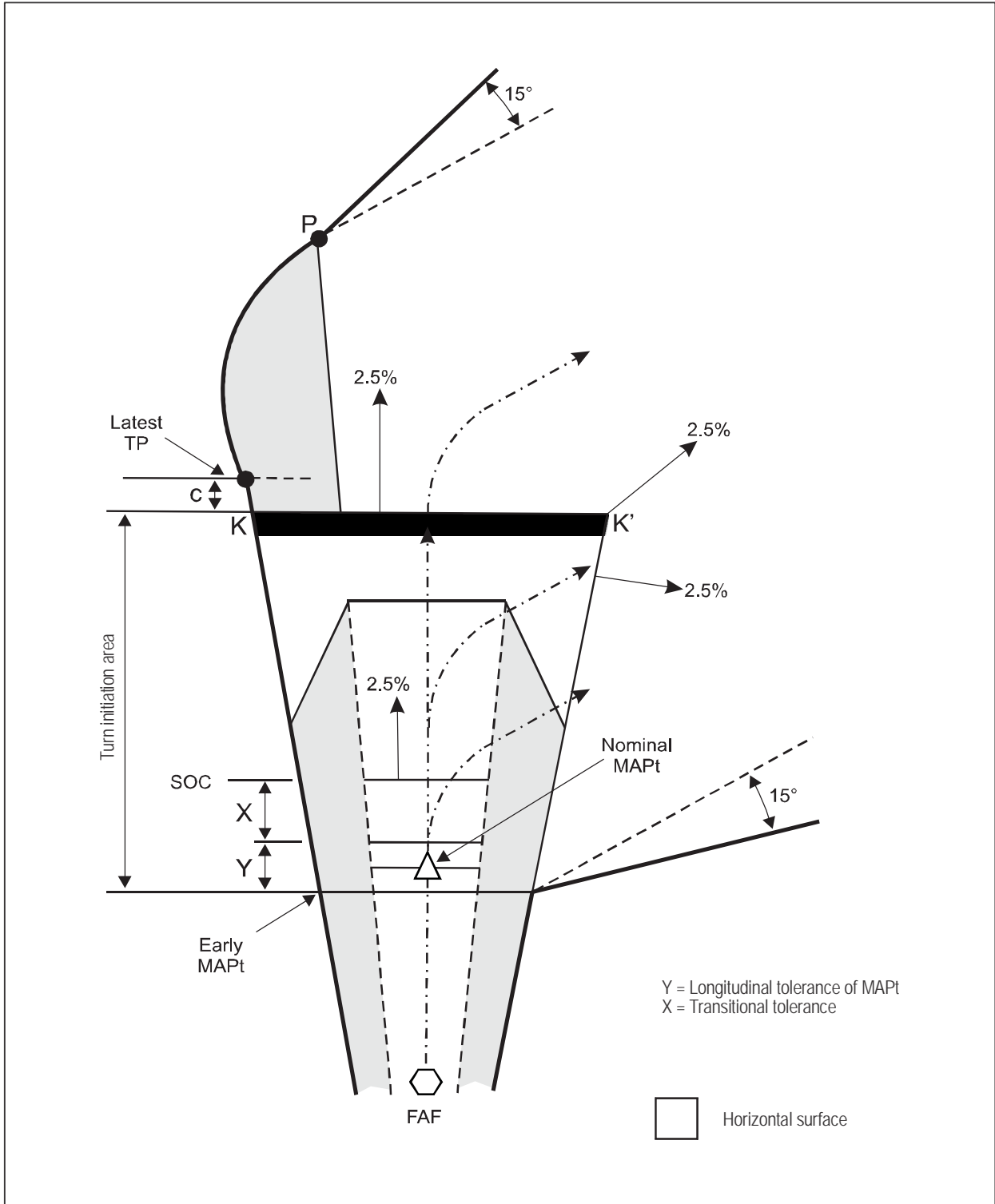

Figure I-4-6-11. Turn less than 75° at an altitude

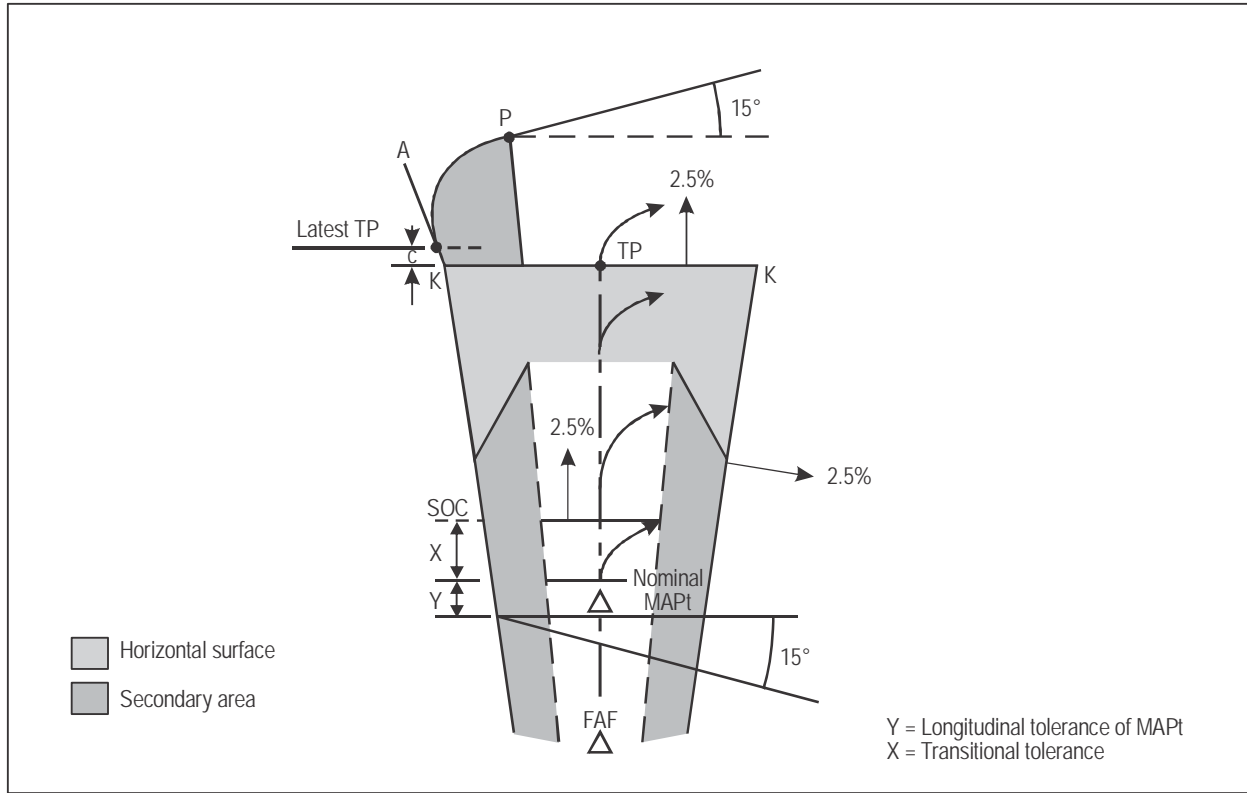

Figure I-4-6-12. Turn more than 75° at an altitude

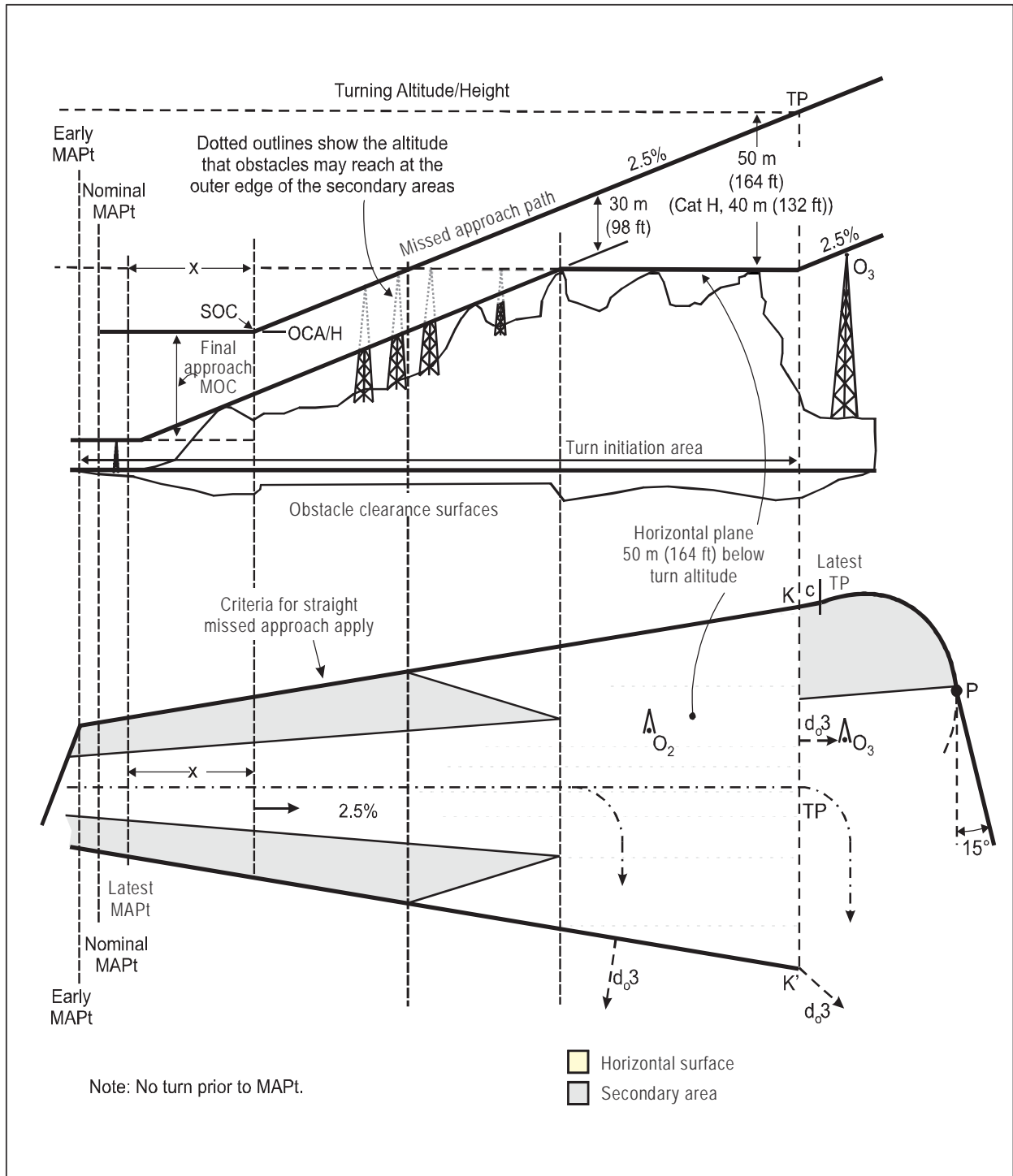

Figure I-4-6-13. Obstacle clearance within turn initiation

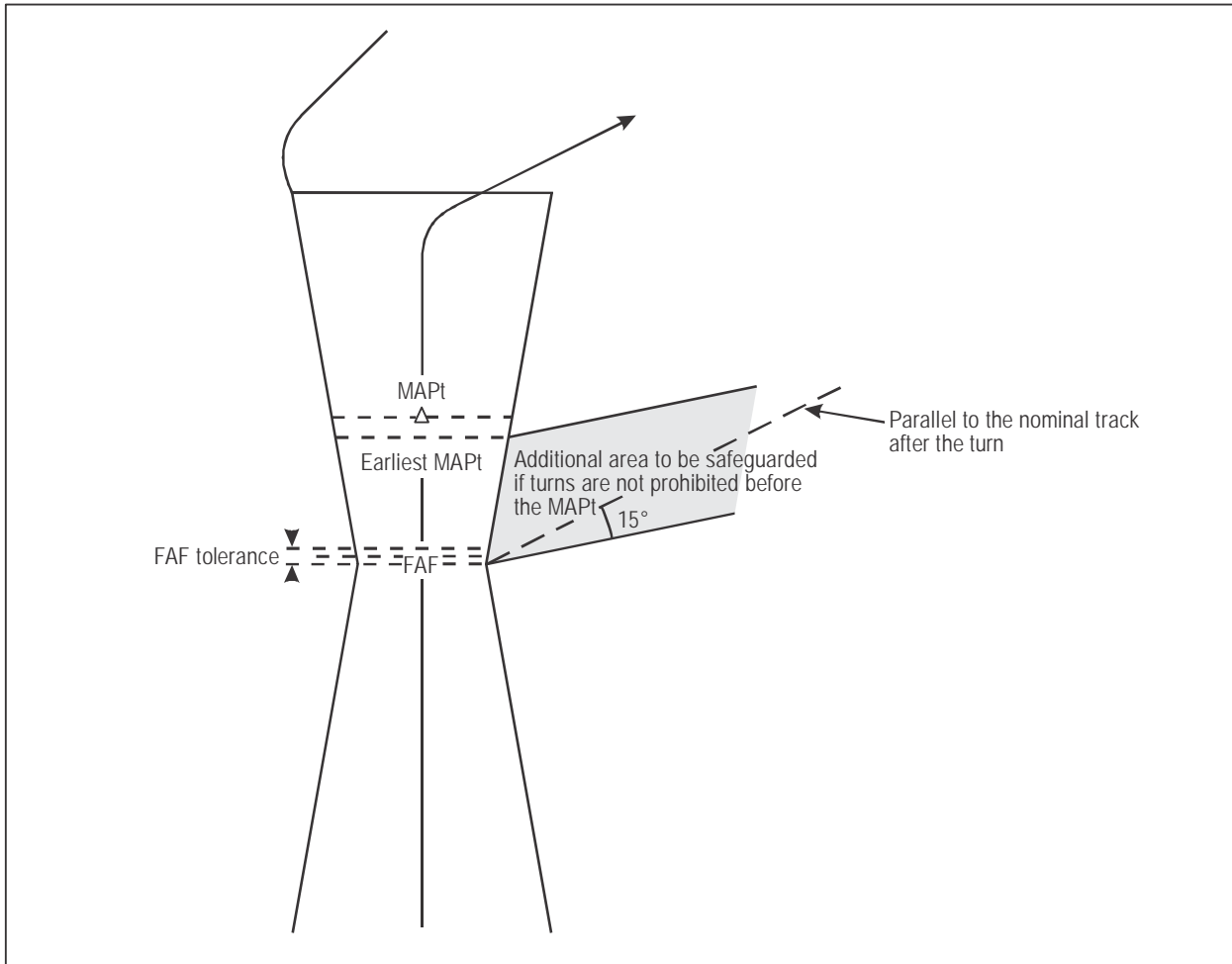

Figure I-4-6-14. Limitation of early turns — additional safeguarding requirement

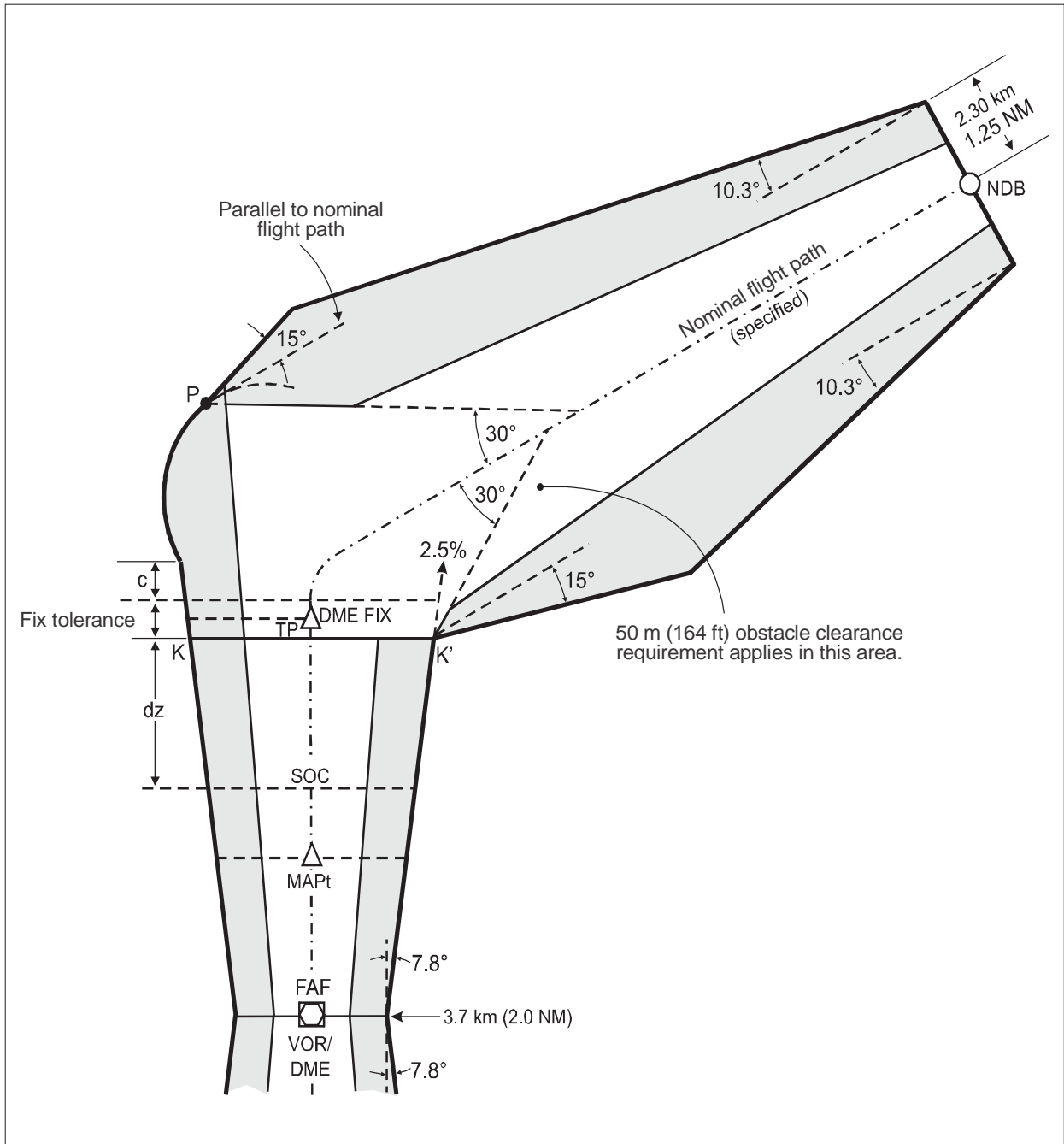

Figure I-4-6-15. Turning missed approach with DME as TP fix

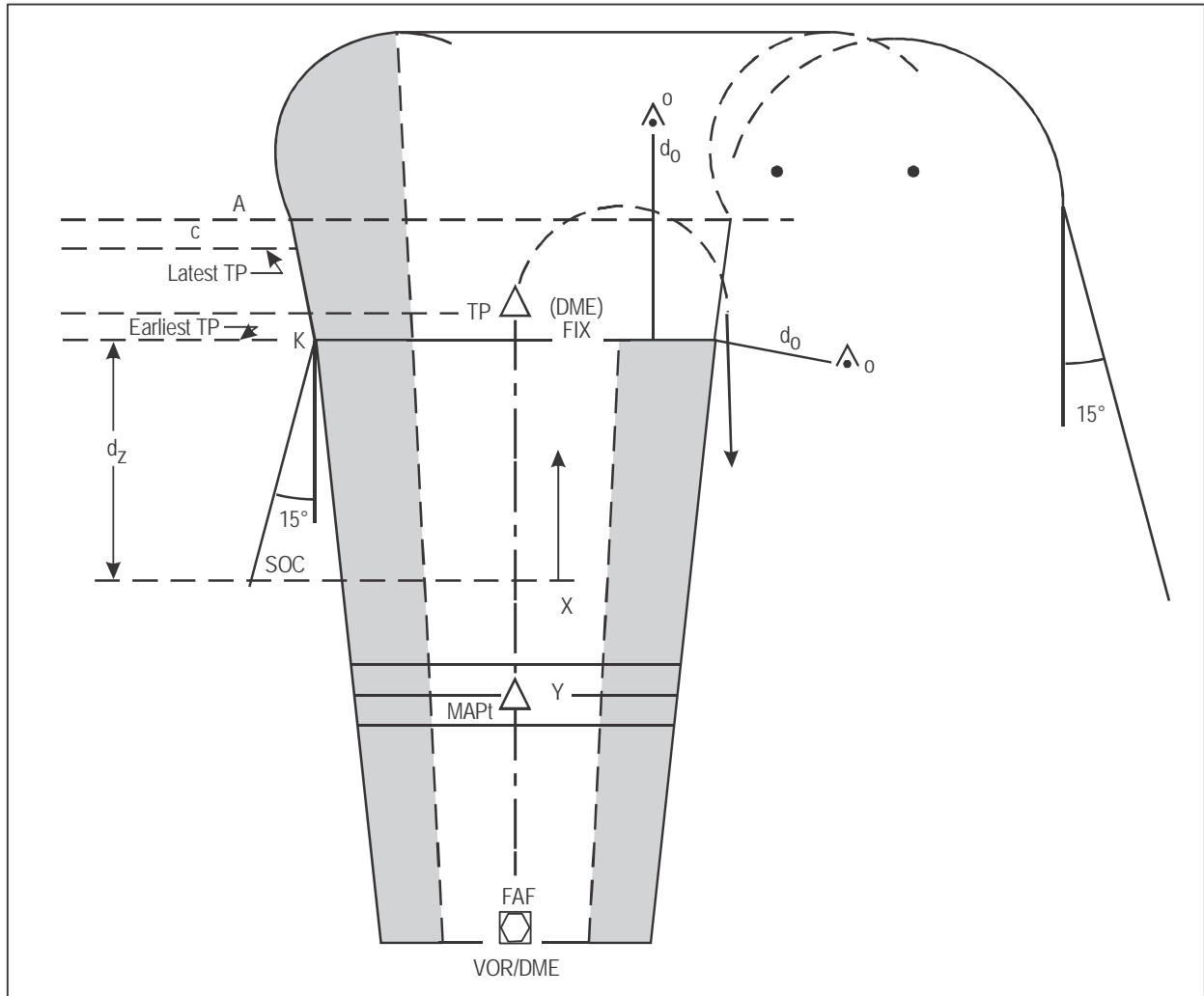

Figure I-4-6-16. 180° turning missed approach with DME as TP fix

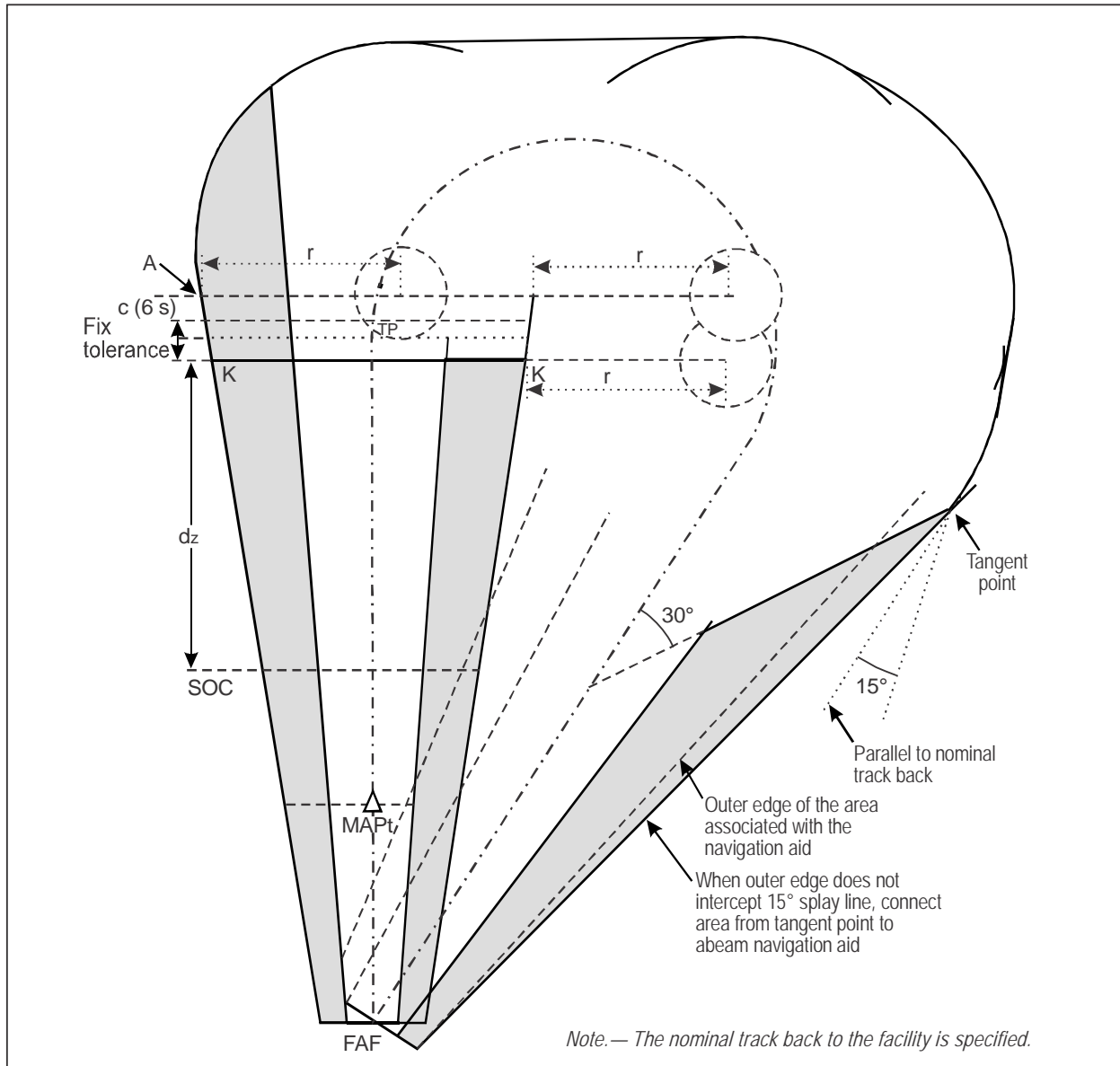

Figure I-4-6-17. Turning missed approach with TP fix and return to the facility with track back

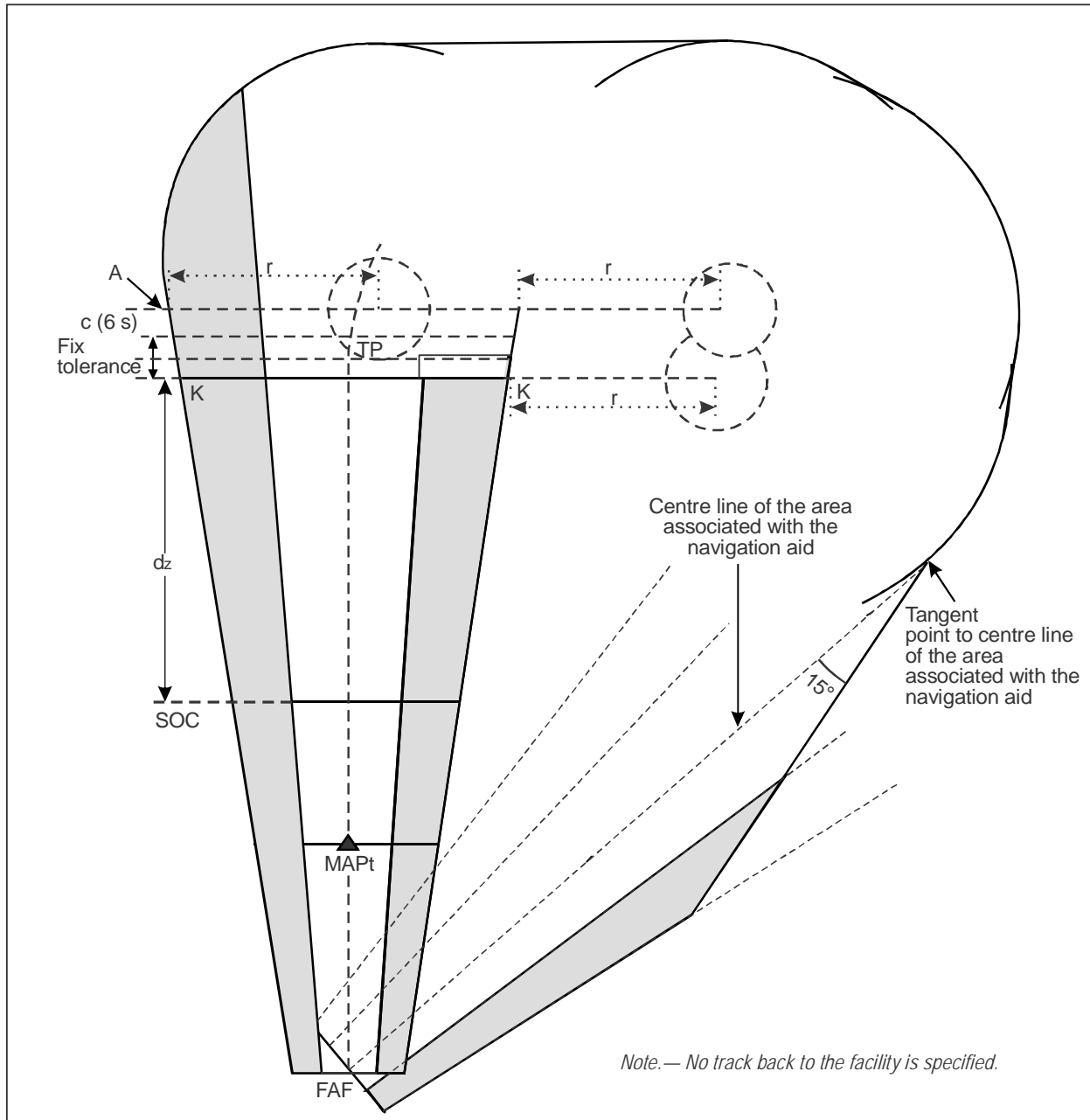

Figure I-4-6-18. Turning missed approach with TP fix and return to the facility without track back

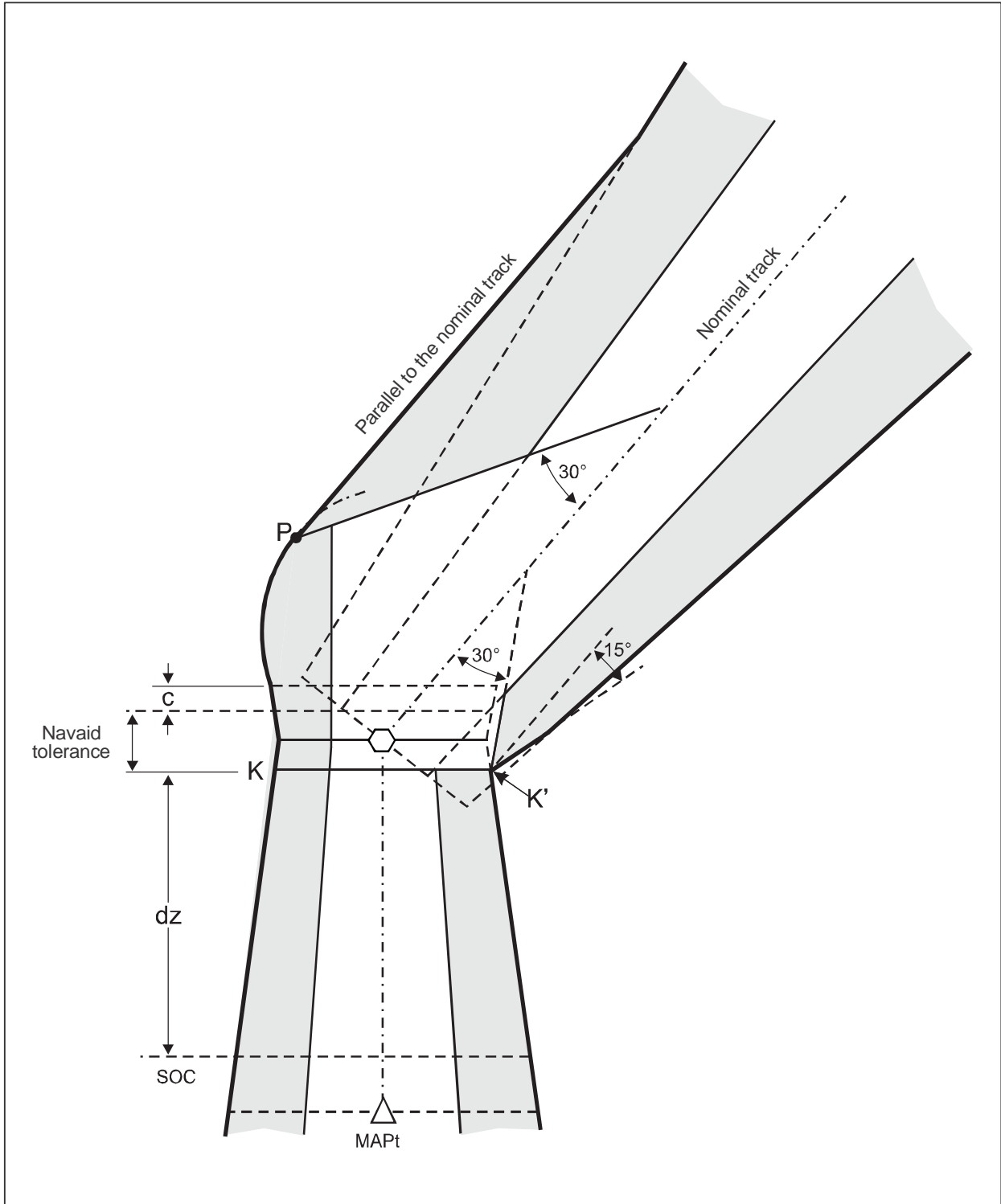

Figure I-4-6-19. Turning missed approach involving turns over a facility

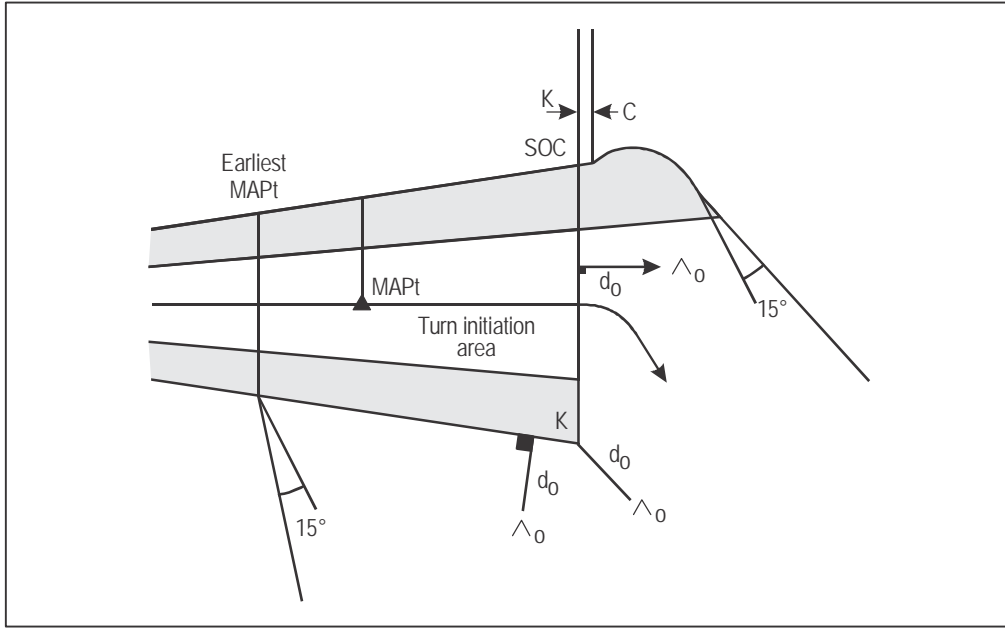

Figure I-4-6-20. Missed approach turn more than 15° at the MAPt

Appendix to Chapter 6

REFINED METHOD FOR CALCULATING MAP_t AND TRANSITIONAL TOLERANCES FOR A MISSED APPROACH POINT DEFINED BY A DISTANCE FROM THE FAF

1. INTRODUCTION

1.1 This appendix shows the full Root Sum Square (RSS) method for calculating:

- a) distance from earliest MAP_t to nominal MAP_t;
- b) distance from nominal MAP_t to latest MAP_t; and
- c) distance from nominal MAP_t to SOC,

when the MAP_t is defined by a distance from the FAF.

1.2 The criteria contained in Part I, Section 4, Chapter 6, 6.1.6.3, “Determining SOC with an MAP_t defined by a distance from the FAF (simplified method)” are conservative in certain cases. To overcome this conservatism, distances may be calculated precisely using the formulas in this appendix.

1.3 The equations shown in Chapter 6, Table I-4-6-1, “Values for Z (Earliest and latest MAP_t for MAP_t determined by distance from the FAF)” and Chapter 6, Table I-4-6-2, “Computation of transitional distance” were derived by linear interpolation from the accurate RSS calculations at the extreme values quoted (i.e. aircraft Categories A to D and for all aerodrome elevations up to 4 000 m (13 000 ft)).

2. CALCULATION

2.1 General

The calculation of each of the relevant distances is done in two steps, using the maximum and minimum final approach speeds for the category of aircraft. The considered distance is the higher of the two found.

2.2 Factors

The empirical RSS method takes into account the following factors:

- a) the fix tolerance at the FAF (assumed as 1.9 km (1.0 NM) to develop the simplified equations in the body of this chapter);
- b) the minimum permissible speed at ISA – 10°C or the maximum permissible speed at ISA + 15°C, whichever is the more critical for each category of aircraft considered;

- c) the effect of a wind of ± 56 km/h (± 30 kt); and
- d) a timing tolerance of -10 to $+13$ seconds which includes a pilot timing tolerance of ± 10 seconds and a pilot reaction time of 0 to $+3$ seconds.

Note.— The value in c) corresponds to the effect of a ± 56 km/h (± 30 kt) unaccounted for wind throughout the final approach segment. This is different from the 19 km/h (10 kt) wind effect considered in the calculation of d and X tolerances. In the latter case the aeroplane path is very close to the ground and the actual wind cannot be much different from the wind reported for the aerodrome.

2.3 Parameters

2.3.1

a = distance from the earliest point of the FAF tolerance to the FAF;

b = distance from the FAF to the latest point of the FAF tolerance;

D = distance from FAF to nominal MAPt;

TASMIN = slowest final approach IAS for the relevant aircraft category (Tables I-4-1-1 and I-4-1-2 in Chapter 1) converted to TAS, allowing for aerodrome elevation and temperature ISA -10 ;

TASMAX = fastest final approach IAS for the relevant aircraft category (Tables I-4-1-1 and I-4-1-2 in Chapter 1) converted to TAS, allowing for aerodrome elevation and temperature ISA $+15$.

2.3.2 Distance from earliest MAPt to nominal MAPt

SI units

$$X1 = (a^2 + (TASMIN \times 10/3600)^2 + (56 \times D/TASMIN)^2)^{0.5}$$

$$X2 = (a^2 + (TASMAX \times 10/3600)^2 + (56 \times D/TASMAX)^2)^{0.5}$$

Non-SI units

$$X1 = (a^2 + (TASMIN \times 10/3600)^2 + (30 \times D/TASMIN)^2)^{0.5}$$

$$X2 = (a^2 + (TASMAX \times 10/3600)^2 + (30 \times D/TASMAX)^2)^{0.5}$$

Distance from earliest MAPt to nominal MAPt = max {X1; X2}

2.3.3 Distance from nominal MAPt to latest MAPt

SI units

$$X3 = (b^2 + (TASMIN \times 13/3600)^2 + (56 \times D/TASMIN)^2)^{0.5}$$

$$X4 = (b^2 + (TASMAX \times 13/3600)^2 + (56 \times D/TASMAX)^2)^{0.5}$$

Non-SI units

$$X3 = (b^2 + (\text{TASMIN} \times 13/3600)^2 + (30 \times D/\text{TASMIN})^2)^{0.5}$$

$$X4 = (b^2 + (\text{TASMAX} \times 13/3600)^2 + (30 \times D/\text{TASMAX})^2)^{0.5}$$

Distance from nominal MAPt to latest MAPt = max {X3; X4}

2.3.4 Distance from nominal MAPt to SOC

SI units

$$X5 = (b^2 + (\text{TASMIN} \times 13/3600)^2 + (56 \times D/\text{TASMIN})^2)^{0.5} + 15 \times (\text{TASMIN} + 19)/3600$$

$$X6 = (b^2 + (\text{TASMAX} \times 13/3600)^2 + (56 \times D/\text{TASMAX})^2)^{0.5} + 15 \times (\text{TASMAX} + 19)/3600$$

Non-SI units

$$X5 = (b^2 + (\text{TASMIN} \times 13/3600)^2 + (30 \times D/\text{TASMIN})^2)^{0.5} + 15 \times (\text{TASMIN} + 10)/3600$$

$$X6 = (b^2 + (\text{TASMAX} \times 13/3600)^2 + (30 \times D/\text{TASMAX})^2)^{0.5} + 15 \times (\text{TASMAX} + 10)/3600$$

Distance from nominal MAPt to SOC = max {X5; X6}.

Chapter 7

VISUAL MANOEUVRING (CIRCLING) AREA

7.1 GENERAL

7.1.1 Definition of terms

Visual manoeuvring (circling) is the term used to describe the visual phase of flight after completing an instrument approach, which brings an aircraft into position for landing on a runway which is not suitably located for straight-in approach, i.e. one where the criteria for alignment or descent gradient cannot be met.

7.1.2 Area to be considered for obstacle clearance

The visual manoeuvring (circling) area is the area in which obstacle clearance shall be considered for aircraft manoeuvring visually (circling).

7.1.3 Visual manoeuvring for helicopters

This chapter does not apply to Category H. In an instrument approach where the landing axis does not permit a straight-in approach, helicopters must conduct a visual manoeuvre under meteorological conditions adequate for seeing and avoiding obstacles in the vicinity of the FATO. The OCA/H for helicopter visual manoeuvring shall not be less than 75 m (246 ft).

7.1.4 Prescribed track for visual manoeuvring

In those locations where clearly defined visual features permit, and if it is operationally desirable, a specific track for visual manoeuvring may be prescribed (in addition to the circling area). See the Appendix to this chapter.

7.2 ALIGNMENT AND AREA

7.2.1 Method for defining the area

7.2.1.1 The size of the visual manoeuvring (circling) area varies with the category of the aircraft. To define the limits of the area:

- a) draw an arc from the centre of the threshold of each usable runway with a radius appropriate to the aircraft category. Example values appear in Tables I-4-7-1 and I-4-7-2;

- b) from the extremities of the adjacent arcs draw lines tangent to the arcs; and
- c) connect the tangent lines.

The area thus enclosed is the visual manoeuvring (circling) area. See Figures I-4-7-1 and I-4-7-2.

7.2.1.2 Note that in Figure I-4-7-1, as an example, the radius for Category E aircraft is used. An operational advantage is gained by casting arcs only from those runways usable by Category E aircraft.

7.2.1.3 In Figure I-4-7-2 all runways are used because they are available to Category A aircraft. However, since the radius for Category A is less than that for Category E the total area for all aircraft is slightly smaller than it would be if Category E criteria were applied completely.

7.2.2 Parameters

The parameters on which visual manoeuvring (circling) radii are based are as follows:

- a) *speed*: speed for each category as shown in Tables I-4-1-1 and I-4-1-2 in Chapter 1;
- b) *wind*: ± 46 km/h (25 kt) throughout the turn; and
- c) *bank*: 20° average achieved or the bank angle producing a turn rate of 3° per second, whichever is the lesser bank. (See Figures II-4-1-App A-2 and II-4-1-App A-3 in Part II, Section 4, Appendix A to Chapter 1, “Parameters for holding area construction”).

7.2.3 Determination method

The radius is determined using the formulas in Section 2, Chapter 3, “Turn area construction”, by applying a 46 km/h (25 kt) wind to the true airspeed (TAS) for each category of aircraft using the visual manoeuvring IAS from Tables I-4-1-1 and I-4-1-2 in Chapter 1. The TAS is based on:

- a) *altitude*: aerodrome elevation + 300 m (1 000 ft); and
- b) *temperature*: ISA + 15° .

7.2.4 Visibility and lowest OCA/H

It is assumed that the minimum visibility available to the pilot at the lowest OCA/H will be as shown in Table I-4-7-3. This information is not required for the development of the procedure, but is included as a basis for the development of operating minima.

7.3 OBSTACLE CLEARANCE

See 5.4.4, “OCA/H for visual manoeuvring (circling)”, and Table I-4-7-3.

7.4 METHOD FOR REDUCING OCA/H

7.4.1 Area which can be ignored

A sector in the circling area where a prominent obstacle exists may be ignored for OCA/H calculations if it is outside the final approach and missed approach areas. This sector is bounded by the dimensions of the Annex 14 instrument approach surfaces. (See Figure I-4-7-3.)

7.4.2 Promulgation

When this option is exercised, the published procedure must prohibit the pilot from circling within the total sector where the obstacle exists. (See Figure I-4-7-4.)

7.5 MISSED APPROACH ASSOCIATED WITH THE VISUAL MANOEUVRE

A missed approach area specific to the visual manoeuvre is not constructed.

7.6 PROMULGATION

The general criteria in Chapter 9, “Charting/AIP” apply. The instrument approach chart for a visual manoeuvre shall be identified by the navigation aid type used for final approach lateral guidance, followed by a single letter suffix, starting with the letter A. The suffix letter shall not be used again for any procedures at that airport, at any other airport serving the same city or at any other airport in the same State, serving a city with the same name. The OCA/H values for the procedure shall be the OCA/H for approach or missed approach, whichever is greater and shall be published in accordance with Chapter 5, 5.5.6, “Publication of OCA/H” and 5.4.4, “OCA/H for visual manoeuvring (circling)”.

Table I-4-7-1. Example of determining radii for visual manoeuvring (circling) area for aerodromes at 300 m MSL (SI-units)

<i>Category of aircraft/IAS (km/h)</i>	<i>A/185</i>	<i>B/250</i>	<i>C/335</i>	<i>D/380</i>	<i>E/445</i>
TAS at 600 m MSL + 46 km/h wind factor (km/h)	241	310	404	448	516
Radius (r) of turn (km)	1.28	2.08	3.46	4.34	5.76
Straight segment (km) (this is a constant value independent of aerodrome elevation)	0.56	0.74	0.93	1.11	1.30
Radius (R) from threshold (km)	3.12	4.90	7.85	9.79	12.82
<i>Note.— Radius from threshold (R) = 2r + straight segment.</i>					

Table I-4-7-2. Example of determining radii for visual manoeuvring (circling) area for aerodromes at 1 000 ft MSL (non-SI units)

<i>Category of aircraft/IAS (kt)</i>	<i>A/100</i>	<i>B/135</i>	<i>C/180</i>	<i>D/205</i>	<i>E/240</i>
TAS at 2 000 ft MSL + 25 kt wind factor (kt)	131	168	215	242	279
Radius (r) of turn (NM)	0.69	1.13	1.85	2.34	3.12
Straight segment (NM) (this is a constant value independent of aerodrome elevation)	0.30	0.40	0.50	0.60	0.70
Radius (R) from threshold (NM)	1.68	2.66	4.20	5.28	6.94
<i>Note.— Radius from threshold (R) = 2r + straight segment.</i>					

Table I-4-7-3. MOC and OCA/H for visual manoeuvring (circling) approach

<i>Aircraft category</i>	<i>Minimum obstacle clearance m (ft)</i>	<i>Lower limit for OCH above aerodrome elevation m (ft)</i>	<i>Minimum visibility km (NM)</i>
A	90 (295)	120 (394)	1.9 (1.0)
B	90 (295)	150 (492)	2.8 (1.5)
C	120 (394)	180 (591)	3.7 (2.0)
D	120 (394)	210 (689)	4.6 (2.5)
E	150 (492)	240 (787)	6.5 (3.5)

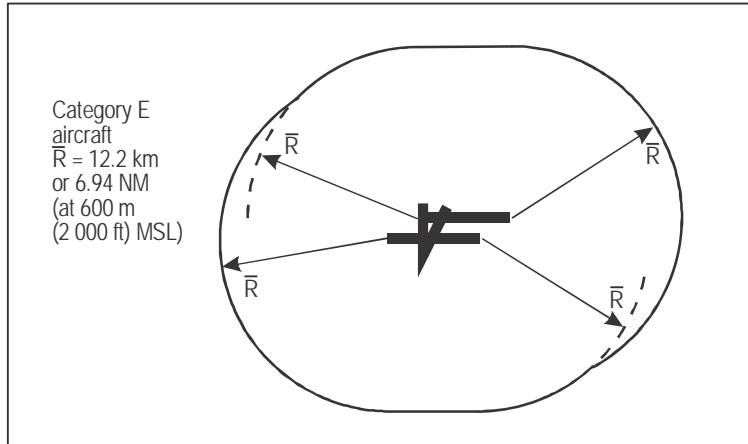

Figure I-4-7-1. Construction of visual manoeuvring (circling) area

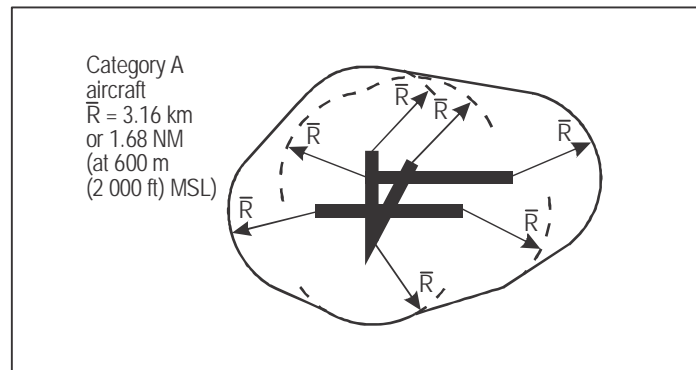

Figure I-4-7-2. Visual manoeuvring (circling) area

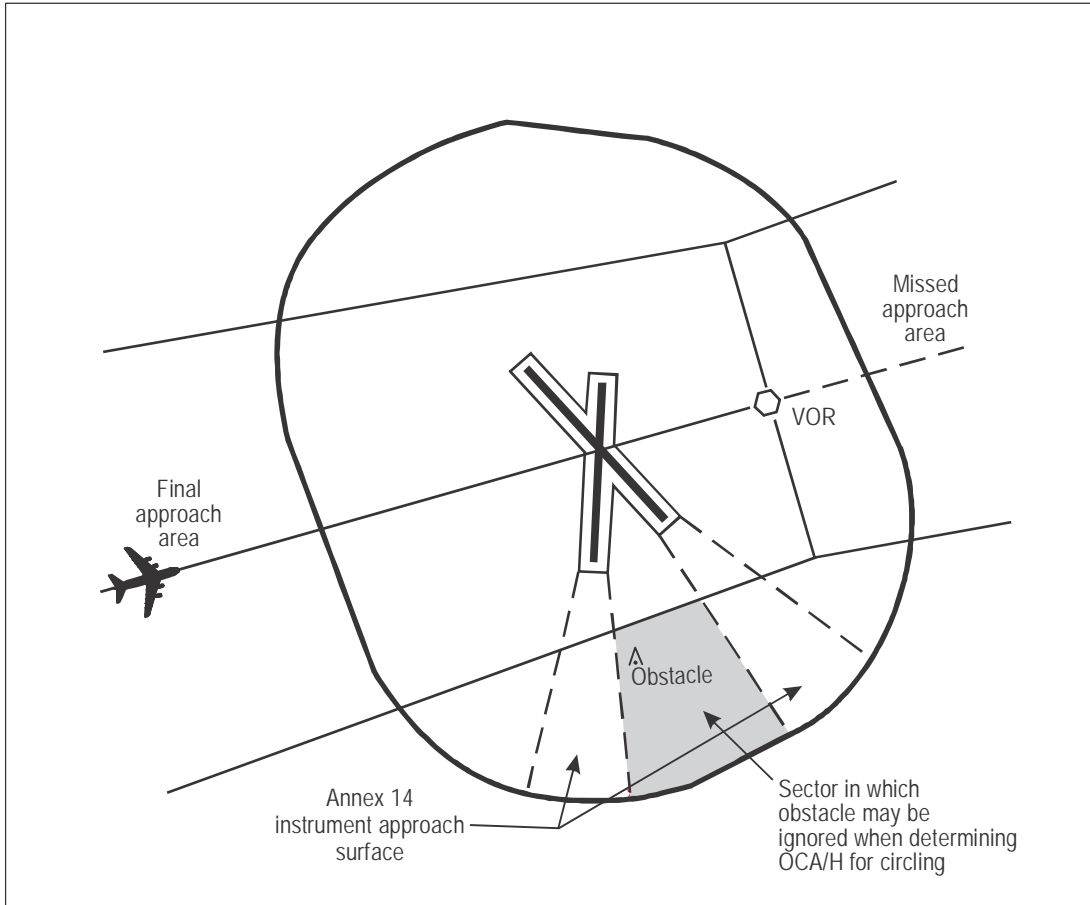

Figure I-4-7-3. Visual manoeuvring (circling) area — obstacle clearance

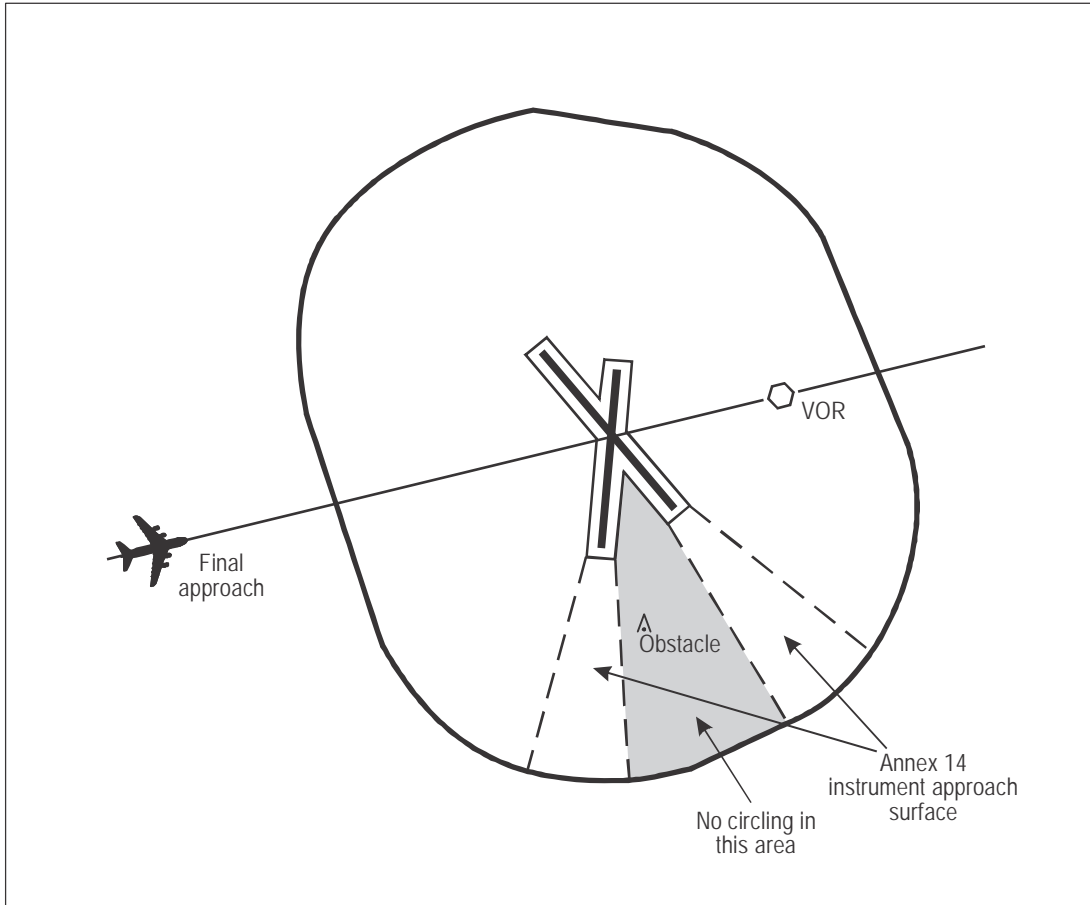

Figure I-4-7-4. Visual manoeuvring (circling) area — prohibition on circling

Appendix to Chapter 7

VISUAL MANOEUVRING USING PRESCRIBED TRACK

1. GENERAL

1.1 In those locations where clearly defined visual features permit, and if it is operationally desirable, a specific track for visual manoeuvring may be prescribed (in addition to the circling area). This track should be included inside the limits of the circling area designed for the same aircraft categories. When it is not the case, the procedure should be named: “VISUAL approach procedure” instead of “VISUAL manoeuvring.”

1.2 The visual features used to define the track and (if necessary) altitude changing points on the track may be complemented with radio fixes (i.e. VOR radial, DME distance, etc.). The tolerance of the radio fix must be equal to or better than the tolerance of the visual feature. A radio fix cannot be used if the corresponding visual feature does not exist.

1.3 At the end of the visual manoeuvring track, a go-around procedure for a second prescribed track manoeuvring is provided. In some cases, the go-around procedure can join the instrument missed approach procedure.

2. TRACK

2.1 Several kinds of tracks have to be considered and the more common cases are illustrated in Figure I-4-7-App-1.

2.2 *Gathering together of the tracks.* It is possible to develop one track for each aircraft category, but for the sake of simplicity, it is recommended that one track be used for all the categories or one for Cat A and B and another for Cat C, D, E, if this does not lead to operational constraints.

2.3 *Diverging point.* This point must be defined with a clearly identifiable visual feature (complemented if necessary by a radio fix with a tolerance less than 0.5 NM, i.e. middle marker or DME distance).

2.4 Diverging segment

2.4.1 This segment joins the final instrument approach segment to the downwind leg of the prescribed track. In some cases, this segment can be replaced by a turn (see Figure I-4-7-App-1 e)) or an S-type manoeuvre (see Figure I-4-7-App-1 c)).

2.4.2 In the case of Figure I-4-7-App-2, it is recommended that the end of the diverging segment occur before the point abeam the threshold used for the prescribed track.

2.4.3 The angle between the diverging segment and the runway used for the prescribed track must be less than or equal to 45°.

2.4.4 The length and magnetic orientation of the diverging segment must be published.

2.5 “Downwind” leg

This segment is parallel to the runway axis; its length is determined by the position of the diverging segment and the length of the final segment of the prescribed track. The length and magnetic orientation of the “downwind” leg must be published.

2.6 Radius of turn

The speed should be the true airspeed, calculated from the maximum indicated airspeed for visual manoeuvring (Tables I-4-1-1 and I-4-1-2 in Chapter 1) for:

- a) *altitude*: aerodrome elevation + 300 m (1 000 ft); and
- b) *temperature*: ISA + 15°C.

Note.— *If necessary (because constraining obstacles have to be avoided) the indicated airspeed may be reduced to not less than the maximum indicated airspeed for the final segment (Tables I-4-1-1 and I-4-1-2) for the aircraft category. In such a case, the maximum indicated speed must be published on the chart.*

2.7 Final segment (of the prescribed track)

The length of the final segment of the prescribed track is based on 30 s of flight at a speed which should be the true airspeed calculated from the maximum indicated airspeed for final approach (Tables I-4-1-1 and I-4-1-2) for:

- a) *altitude*: aerodrome elevation + 300 m (1 000 ft); and
- b) *temperature*: ISA + 15°C.

When a minimum altitude has to be maintained at the beginning of this segment, the procedures designer should check its length to allow a final descent gradient less than 10 per cent (optimum: 5.2 per cent/3°).

2.8 Bank

25° average achieved bank angle.

2.9 Go-around track

In all cases, the prescribed track provides for a go-around trajectory. In general, this manoeuvre consists of a 180° turn starting at the end of the runway and reaching the “downwind” leg of the prescribed track. When this kind of procedure is not appropriate, if there is a constraining obstacle under the 180° turn manoeuvre or if there is a special kind of prescribed track (Figure I-4-7-App-3), a go-around procedure to join the instrument missed approach will be prescribed.

3. AREA ASSOCIATED WITH PRESCRIBED TRACK

This area is based on the nominal track, plus a buffer area of width (w) on the outside of the nominal track. The buffer area starts at the “diverging” point and follows the track, including a go-around for a second visual manoeuvre with prescribed track. (See Table I-4-7-App-1 and Figure I-4-7-App-4.)

4. MINIMUM OBSTACLE CLEARANCE AND OCA/H

The OCA/H for visual manoeuvring on prescribed tracks shall provide the minimum obstacle clearance (MOC) over the highest obstacle within the prescribed track area. It shall also conform to the limits specified at Table I-4-7-App-2 and be not less than the OCA/H calculated for the instrument approach procedure which leads to the visual manoeuvre.

5. VISUAL AIDS

Visual aids associated with the runway used for the prescribed track (i.e. sequenced flashing lights, PAPI, VASIS) are shown on the approach chart with their main characteristics (i.e. slope of the PAPI or VASIS). Lighting on obstacles is specified on the approach chart.

Table I-4-7-App-1. Semi-width of the corridor

<i>Aircraft category</i>	<i>A</i>	<i>B</i>	<i>C</i>	<i>D</i>	<i>E</i>
semi-width of the corridor (w)					
metres	1 400	1 500	1 800	2 100	2 600
(feet)	4 593	4 921	5 905	6 890	8 530

Table I-4-7-App-2. Minimum OCA/H for visual manoeuvring using prescribed tracks

<i>Aircraft category</i>	<i>Obstacle clearance m (ft)</i>	<i>Lower limit for OCH above aerodrome elevation m (ft)</i>	<i>Minimum visibility km (NM)</i>
A	90 (295)	120 (394)	1.9 (1.0)
B	90 (295)	150 (492)	2.8 (1.5)
C	120 (394)	180 (591)	3.7 (2.0)
D	120 (394)	210 (689)	4.6 (2.5)
E	150 (492)	240 (787)	6.5 (3.5)

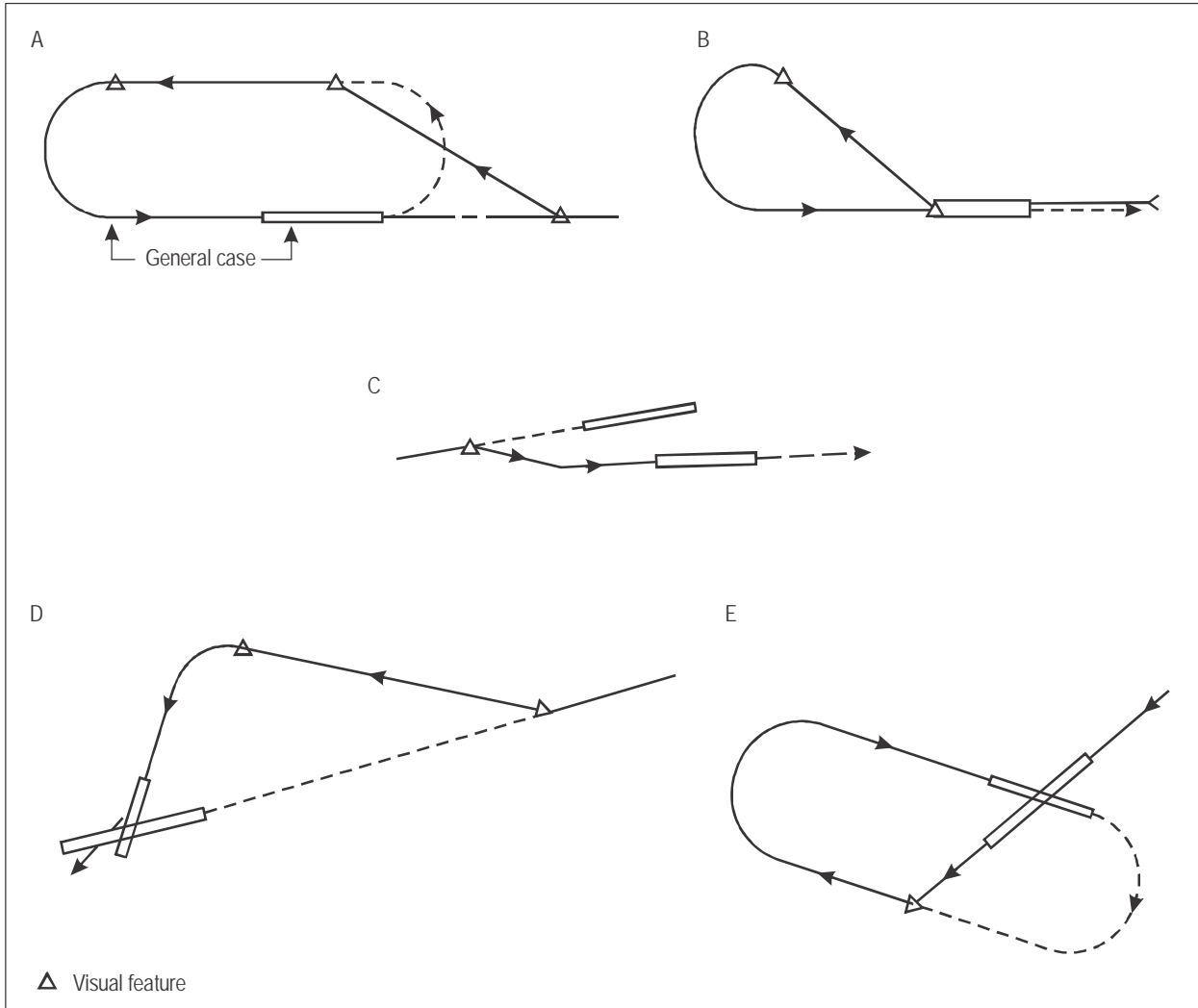

Figure I-4-7-App-1. Common cases of tracks

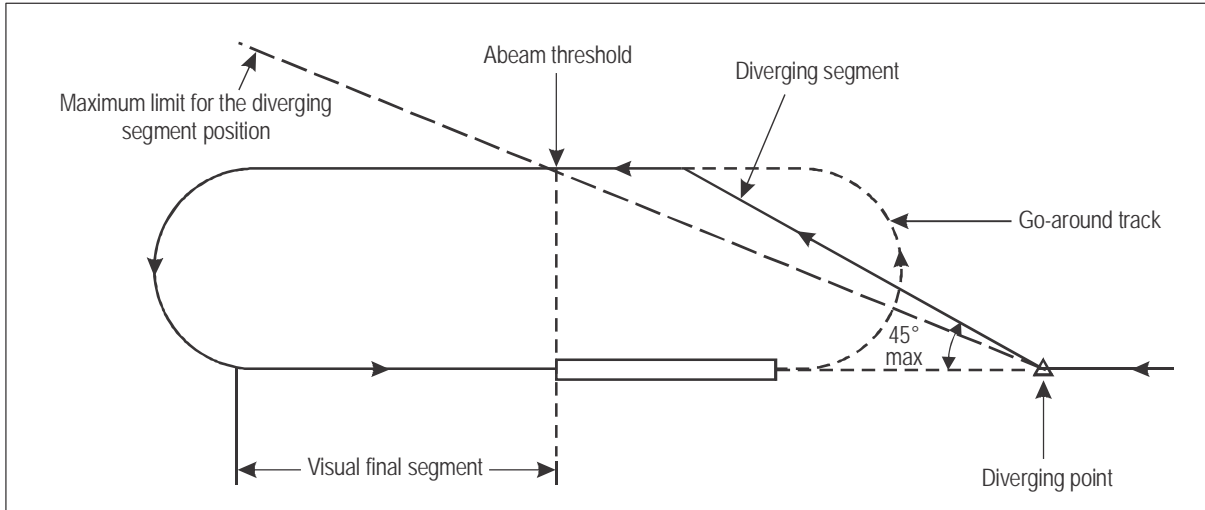

Figure I-4-7-App-2. Standard track general case

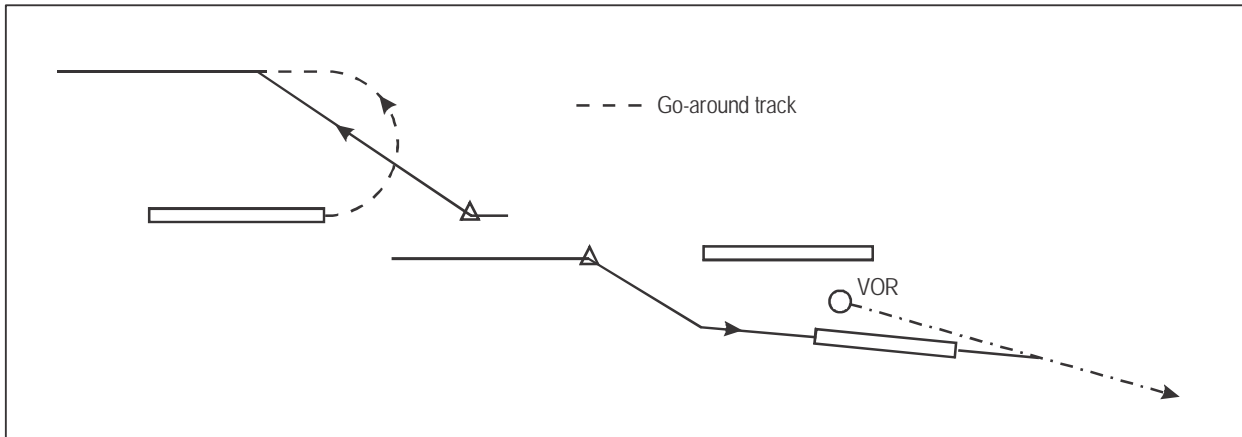

Figure I-4-7-App-3. Prescribed track for go-around

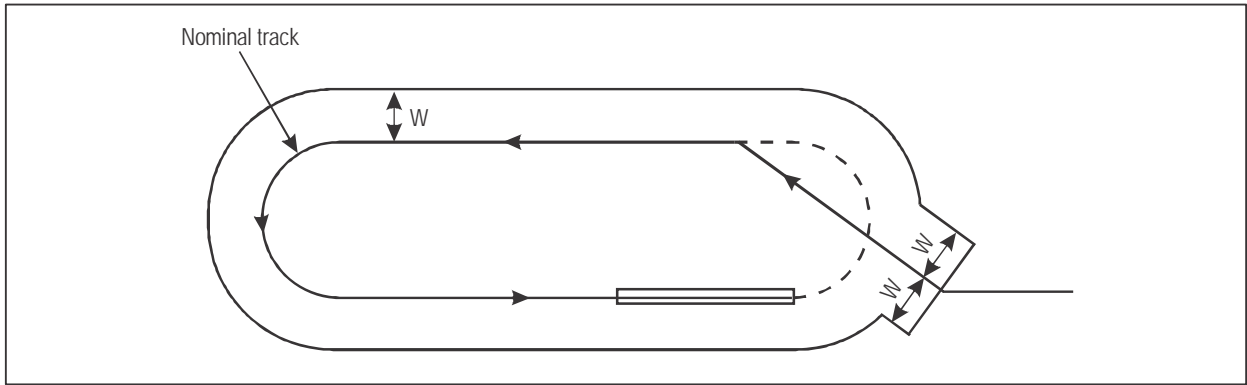

Figure I-4-7-App-4. Area

Chapter 8

MINIMUM SECTOR ALTITUDES (MSA)

8.1 GENERAL

8.1.1 Minimum sector altitudes shall be established for each aerodrome where instrument approach procedures have been established. Each minimum sector altitude shall be calculated by:

- a) taking the highest elevation in the sector concerned;
- b) adding a clearance of at least 300 m (1 000 ft); and
- c) rounding the resulting value up to the next higher 50-m or 100-ft increment, as appropriate.

8.1.2 If the difference between sector altitudes is insignificant (i.e. in the order of 100 m or 300 ft as appropriate) a minimum altitude applicable to all sectors may be established.

8.1.3 A minimum altitude shall apply within a radius of 46 km (25 NM) of the significant point, the aerodrome reference point (ARP), or the heliport reference point (HRP) on which the instrument approach is based. The minimum obstacle clearance when flying over mountainous areas should be increased by as much as 300 m (1 000 ft).

8.2 OBSTACLES IN BUFFER AREA

Obstacles within a buffer zone of 9 km (5 NM) around the boundaries of any given sector shall be considered as well. If such obstacles are higher than the highest obstacle within the sector, then the minimum sector altitude shall be calculated by:

- a) taking the highest elevation in the buffer area concerned;
- b) adding a clearance of at least 300 m (1 000 ft); and
- c) rounding the resulting value up to the nearest 50 m (100 ft).

8.3 SECTOR ORIENTATION

The sectors should normally coincide with the quadrants of the compass. However, when topographical or other conditions make it desirable, the boundaries of the sectors may be chosen to obtain the most favourable minimum sector altitudes. See Figure I-4-8-1.

8.4 COMBINING SECTORS FOR ADJACENT FACILITIES

8.4.1 Where more than one facility provides instrument approaches to an aerodrome, and several minimum sector altitude diagrams are involved, individual diagrams shall be produced and minimum sector altitudes calculated.

8.4.2 If such facilities are located less than 9 km (5 NM) apart, the minimum sector altitude for any given sector should be the highest of all altitudes calculated for that specific sector for every facility serving the aerodrome.

8.5 SECTORS CENTRED ON A VOR/DME OR NDB/DME

8.5.1 In sectors centred on a VOR/DME or NDB/DME, it is possible to define an additional boundary (DME arc) within a sector, dividing the sector into two subsectors with the lower MSA in the inner area.

8.5.2 The DME arc radius (R) used should be between 19 and 28 km (10 and 15 NM) in order to avoid the use of a subsector of too small a size. The width of the buffer area between the subsectors remains 9 km (5 NM) (see Figure I-4-8-2).

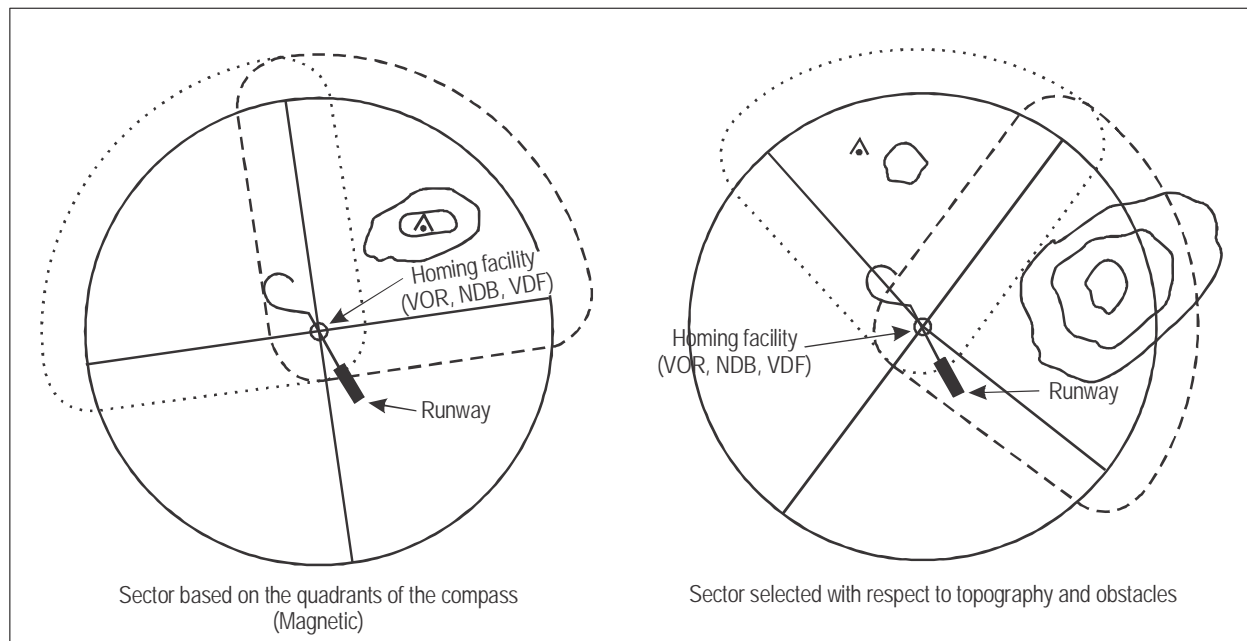

Figure I-4-8-1. Sector orientation

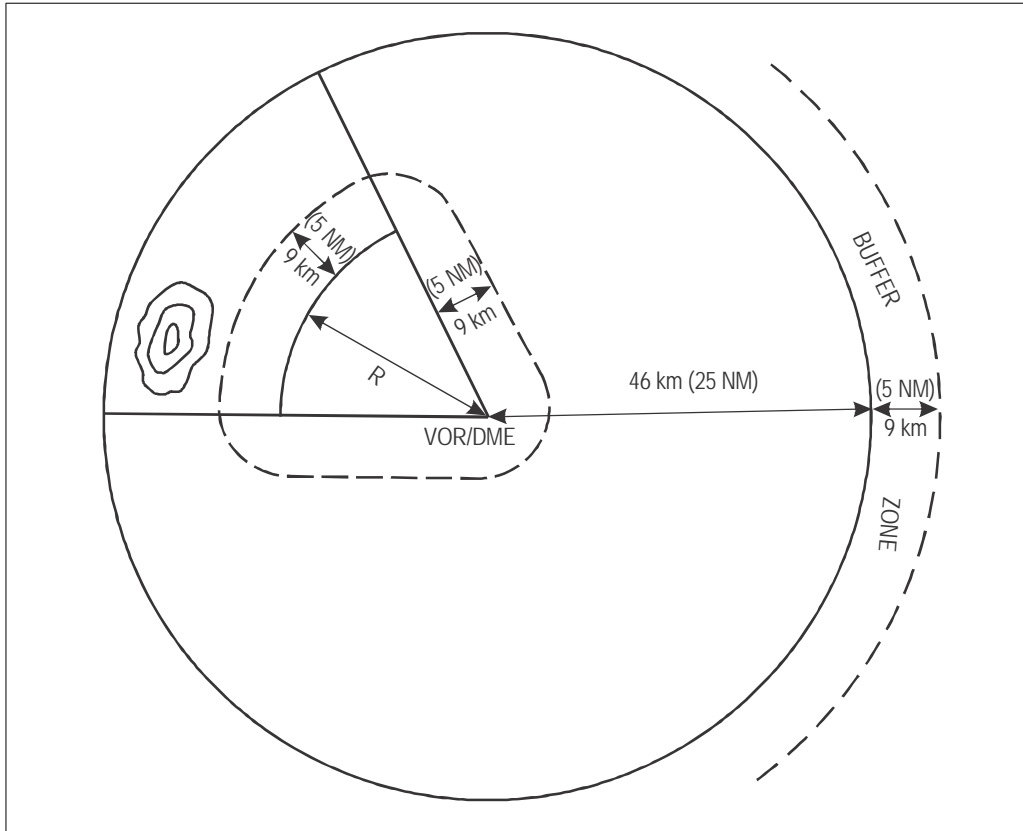

Figure I-4-8-2. Case of VOR/DME subsectors delimited by a DME arc

Chapter 9

CHARTING/AIP

9.1 GENERAL

Material relating to the publication of charts is contained in Annex 4 as follows:

- a) Standard Departure Chart — Instrument (SID) — ICAO, in Annex 4, Chapter 9;
- b) Standard Arrival Chart — Instrument (STAR) — ICAO, in Annex 4, Chapter 10; and
- c) Instrument Approach Chart — ICAO, in Annex 4, Chapter 11.

9.2 CHARTED ALTITUDES/FLIGHT LEVELS

Altitude depiction. Arrival procedures may be developed to procedurally separate air traffic. In doing so, the procedure may be accompanied with altitudes/flight levels that are not associated with any obstacle clearance requirements, but are developed to separate arriving and departing air traffic procedurally. These altitudes/flight levels shall be charted as indicated in Table I-4-9-1. The method of charting of altitudes/flight levels to correctly depict the designed procedure may differ between avionics manufacturers.

9.3 ARRIVAL

In some cases it is necessary to designate arrival routes from the en-route structure to the initial approach fix. Only those routes which provide an operational advantage shall be established and published. These should take local air traffic flow into consideration.

9.4 APPROACH

9.4.1 General

9.4.1.1 Optimum and maximum descent gradients and angles are specified depending on the type of procedure and the segment of the approach. The descent gradient(s)/angles used in the construction of the procedure shall be published for the final approach segment. It is preferable that they also be published for the other approach segments, where appropriate.

9.4.1.2 *Fix identification.* The IAF, IF, FAF, MAPt, TP and other essential fixes or points where established are published on the approach chart.

9.4.1.3 *Aeronautical database requirements.* For non-RNAV approaches the following data shall be published in tabular form on the verso of the ICAO Instrument Approach Chart or as a separate, properly referenced sheet (see Annex 4, Chapter 11):

- a) final approach fixes/points and other essential fixes/points comprising the instrument approach procedure identified with their geographical coordinates in degrees, minutes, seconds and tenths of seconds;
- b) instrument approach procedure fix formation bearings to the nearest hundredth of a degree;
- c) instrument approach procedure fix formation distance to the nearest hundredth of a nautical mile; and
- d) for non-precision approaches, the final approach descent angle to the nearest hundredth of a degree.

9.4.2 Initial approach segment

9.4.2.1 Separate procedures shall be published when:

- a) different minimum altitudes;
- b) different timings; or
- c) different outbound tracks

are specified for different categories of aircraft.

9.4.2.2 Speeds below the minimum value for initial approach in a given aircraft category shall not be specified (see Tables I-4-1-1 and I-4-1-2 of Chapter 1). If procedures are developed which exclude specific aircraft categories due to speed, this must be stated explicitly.

9.4.3 Final approach segment

9.4.3.1 An OCA and/or an OCH shall be published for each instrument approach and circling procedure. For non-precision approach procedures, values shall be expressed in 5-m or 10-ft increments by rounding up as appropriate.

9.4.3.2 A straight-in OCA/H shall not be published where final approach alignment or descent gradient criteria are not met. In this case, only circling OCA/H shall be published.

9.4.3.3 Procedures which require the use of forecast altimeter setting shall be suitably annotated on the approach charts.

9.4.3.4 *Steep angle approach.* For procedures with a final descent gradient/angle greater than the maximum value specified in Chapter 5, “Final Approach Segment”, a warning note shall be published on the instrument approach chart (See Annex 4, 11.10.8.8).

9.4.3.5 *Vertical guidance.* Where distance information is available, to facilitate a continuous descent final approach (CDFA), descent profile advisory information for the final approach should be provided to assist the pilot in maintaining the calculated descent gradient. This information should consist of a table showing altitudes/heights through which the aircraft should be passing at each 2 km or 1 NM as appropriate.

9.4.4 Missed approach segment

9.4.4.1 If the MAPt is defined by a facility or fix at the MAPt only, the procedure must be annotated “timing not authorized for defining the MAPt”.

9.4.4.2 If the MAPt is defined by a combination of timing over the distance from the nominal FAF to the nominal MAPt, in addition to a facility or fix at the missed approach point, the OCA/Hs for both timing and fix shall be published if an operational advantage can be obtained in this way. Alternatively a single OCA/H shall be published (which shall be the higher of the two).

9.4.4.3 The OCA/H for the nominal 2.5 per cent must always be published on the instrument approach chart. If additional climb gradients are specified in the construction of the missed approach procedure, they and their associated OCA/H values must be published as alternative options.

9.4.4.4 The speed for final missed approach is shown in Tables I-4-1-1 and I-4-1-2 of Chapter 1. However, where operationally required to avoid obstacles, reduced speeds as slow as the IAS for intermediate missed approach may be used, provided the procedure is annotated “Missed approach turn limited to _____ km/h (kt) IAS maximum.”

9.4.4.5 When a gradient other than the nominal gradient is used in the construction of the missed approach procedure this must be indicated in the instrument approach chart and, in addition to the OCA/H for the specific gradient, the OCA/H applicable to the nominal gradient must also be shown.

9.4.5 Visual manoeuvring

9.4.5.1 A sector in the circling area where a prominent obstacle exists may be ignored for OCA/H calculations if it meets the criteria listed in Chapter 7, 7.4.1, “Area which can be ignored”.

9.4.5.2 When this option is exercised, the published procedure must prohibit the pilot from circling within the total sector where the obstacle exists.

9.4.6 Visual manoeuvring with prescribed track

9.4.6.1 The length and magnetic orientation of the diverging segment must be published.

9.4.6.2 The length and magnetic orientation of the “downwind” leg must be published.

9.4.6.3 *Radius of turn.* If necessary (because constraining obstacles have to be avoided) the indicated airspeed may be reduced to not less than the maximum indicated airspeed for the final segment (Tables I-4-1-1 and I-4-1-2 of Chapter 1) for the aircraft category. In such a case, the maximum indicated speed must be published on the chart.

9.5 PROCEDURE NAMING FOR ARRIVAL AND APPROACH CHARTS

9.5.1 Instrument flight procedure naming convention

This paragraph describes the general aspects of instrument procedure naming. Specific aspects are covered in the appropriate chapters. A standardized naming convention is required to avoid ambiguity between charts, electronic cockpit displays and ATC clearances. This convention affects the following charting aspects:

- a) procedure identification;
- b) additional equipment requirements; and
- c) minima boxes.

9.5.2 Procedure chart identification

9.5.2.1 *General.* The chart identification for procedures requiring ground-based navaids shall only contain the name describing the type of radio navigation aid providing the final approach lateral guidance. Precision approach systems such as ILS or MLS shall be identified by the system name (ILS, MLS, etc.). If two radio navigation aids are used for final approach lateral guidance, the chart identification shall only include the last radio navigation aid used. For example:

if an NDB is used as the final approach fix and a VOR is used as the last navaid on the final approach to runway 06, the procedure shall be identified as VOR Rwy 06. If a VOR is used for the initial approach followed by a final approach to Rwy 24 using an NDB, the procedure shall be identified as NDB Rwy 24.

Note.— For chart identification of procedures supporting PBN, refer to Part III, Section 5, Chapter 1.

9.5.2.2 If additional navigation aids or equipment are required for the approach procedure, associated additional equipment requirements shall be specified on the plan view of the chart, but not in the the chart identification.

9.5.2.2.1 The equipment requirements mentioned on the plan view refer only to the equipment on board the aircraft necessary to conduct the procedure in normal mode (i.e. not for backup). For example:

“ADF required ” on a VOR approach.

“Dual ADF required”, on an NDB approach where two ADFs are required to fly the final approach segment.

“DME required” on a VOR approach.

9.5.2.2.2 Equipment that is required in the corresponding airspace may be mentioned as equipment requirements.

9.5.2.2.3 Optional carriage of equipment that may support lower minima shall be evident from the minima box. In such a case it is not necessary to provide a note on the chart. See 9.5.4.

9.5.2.3 *Multiple procedures.* A single approach chart may portray more than one approach procedure when the procedures for the intermediate approach, final approach and missed approach segments are identical, except in the case of RNP procedures supported by different navigation specifications for the final approach segment. If more than one approach procedure is depicted on the same chart, the title shall contain the names of all the types of navigation aids used for final approach lateral guidance, separated by the word “or”. There shall be no more than three types of approach procedure on one chart. For example:

ILS or NDB Rwy 35L

9.5.2.4 *Helicopter approach.* Helicopter approaches to a runway shall be identified in the same way as fixed wing approaches, with the Category H included in the Minima Box. A helicopter approach to a point in space or a helipad shall be identified by the navigation aid type used for final approach guidance, followed by the final approach track or radial. For example:

VOR 235

9.5.2.5 *Circling approach.* When on a chart only circling minima are provided, the approach procedure shall be identified by the last navaid providing final approach guidance followed by a single letter, starting with the letter a. When there are two or more approaches at an airport (or a nearby airport), a different letter shall be used. If the IFR portion of the procedure is the same but there are different circling tracks for the same procedure, only one procedure with one title should be promulgated and the different circling procedures indicated in the procedure. The suffix letter shall not be used again for any procedures at that airport, at any other airport serving the same city, or at any other airport in the same State, serving a city with the same name. For example:

VOR-A

VOR-B

NDB-C

9.5.3 Duplicate procedure identification

9.5.3.1 A single letter suffix, starting with the letter z following the radio navigation aid type shall be used if two or more procedures to the same runway cannot be distinguished by the radio navigation aid type only. For example:

VOR Y RWY 20

VOR Z RWY 20

9.5.3.2 The single letter suffix shall be used when:

- a) two or more navigation aids of the same type are used to support different approaches to the same runway;
- b) two or more missed approaches are associated with a common approach, each approach being identified by a single letter suffix;
- c) different approach procedures using the same radio navigation type are provided for different aircraft categories;
- d) two or more arrivals are used to a common approach and are published on different charts, each approach being identified by a single letter suffix. If additional radio navigation aids are required for the arrival they shall be specified on the chart's plan view. For example:

ILS y RWY 20 (“CAB VOR Arrival” shown in the plan view)

ILS z RWY 20 (“DNA VOR Arrival” shown in the plan view)

9.5.3.3 Some avionics systems are not capable of recognizing the duplicate procedure identification as defined in paragraphs 9.5.3.1 and 9.5.3.2. The systems that are not capable will include only one of the duplicate procedures and will not include the duplicate procedure identification letter. States may therefore employ some method of indicating which procedure should be included in those systems, e.g. a note in the AIP, listing of procedures, the consistent use of a defined character for the identification.

9.5.4 Minima boxes

9.5.4.1 The OCA/H for each aircraft category shall be published in the minima box on the chart. Where an OCA/H is predicated on a specific navigation aid (e.g. stepdown fixes), or a specific navigation specification (see Part III, Section 5, Chapter 1, 1.4), this shall be clearly identified. For example:

OCA/(OCH)	CAT A	CAT B	CAT C	CAT D	CAT H
VOR/DME	610 (300)	610 (300)	610 (300)	610 (300)	610 (300)
VOR	660 (350)	660 (350)	660 (350)	660 (350)	660 (350)

or

OCA/(OCH)	CAT A	CAT B	CAT C	CAT D	CAT H
CAT I	210 (170)	210 (170)	220 (180)	230 (190)	210 (170)
LOC/DME	290 (250)	290 (250)	290 (250)	290 (250)	290 (250)

Table I-4-9-1. Charted altitudes/flight levels

Altitude/flight level “Window”	<u>17 000</u> <u>10 000</u>	<u>FL220</u> <u>10 000</u>
“At or above” altitude/flight level	<u>7 000</u>	<u>FL60</u>
“At or below” altitude/flight level	<u>5 000</u>	<u>FL50</u>
“Mandatory” altitude/flight level	<u>3 000</u>	<u>FL30</u>
“Recommended” procedure altitude/flight level	5 000	FL50
“Expected” altitude/flight level	Expect 5 000	Expect FL50

**Procedures for
Air Navigation Services**

AIRCRAFT OPERATIONS

Part II

CONVENTIONAL PROCEDURES

Section 1

PRECISION APPROACHES

Chapter 1

INSTRUMENT LANDING SYSTEM (ILS)

1.1 INTRODUCTION

1.1.1 Application

The ILS criteria detailed in this chapter are related to the ground and airborne equipment performance and integrity required to meet the Category I, II and III operational objectives described in Annex 10.

1.1.2 Procedure construction

The procedure from en route to the precision segment of the approach and in the final missed approach phase conforms with the general criteria as presented in Part I, Section 1, 2 and 4. The differences are found in the physical requirements for the precision segment which contains the final approach segment as well as the initial and intermediate phases of the missed approach segment. These requirements are related to the performance of Cat I, II and III systems.

1.1.3 Standard conditions

The following list contains the standard assumptions on which procedures are developed. Provisions are made for adjustments where appropriate. Adjustments are mandatory when conditions differ adversely from standard conditions and are optional when so specified (see 1.4.8.7, “Adjustment of OAS constants”).

- a) Maximum aircraft dimensions are assumed to be the following:

<i>Aircraft category</i>	<i>Wingspan</i>	<i>Vertical distance between the flight paths of the wheels and the GP antenna (m)</i>
H	30	3
A, B	60	6
C, D	65	7
D _L	80	8

Note 1.— OCA/H for Cat D_L aircraft is published when necessary.

Note 2.— The dimensions shown are those which encompass current aircraft types. They are chosen to facilitate OCA/H calculations and promulgation of aircraft category related minima. It is assumed that these dimensions are not intended to be used for other purposes than the OCA/H calculations in other ICAO documents. The use of OAS surfaces to calculate OCA/H may result in significant differences between aircraft categories because of small

differences in size. For this reason, it is always preferable to use the Collision Risk Model (1.4.9) which will allow for more realistic assessment for both height and position of obstacles. When applying OAS methodology to determine OCH, new larger aircraft with performance as demonstrated in ICAO Circular 301 may be treated as standard Category C or D aircraft, without correcting the OAS for wingspan and/or vertical dimension.

Note 3.— Current Category E aircraft are not normally civil transport aircraft and their dimensions are not necessarily related to V_{at} at maximum landing mass. For this reason, they should be treated separately on an individual basis.

- b) Category II flown with flight director.
- c) Missed approach climb gradient 2.5 per cent.
- d) ILS sector width 210 m at threshold.
- e) Glide path angle:
 - 1) minimum: 2.5°;
 - 2) optimum: 3.0°;
 - 3) maximum: 3.5° (3° for Cat II/III operations).
- f) ILS reference datum height 15 m (50 ft).
- g) All obstacle heights are referenced to threshold elevation.
- h) For Cat II and Cat III operations the Annex 14 inner approach, inner transitional and balked landing surfaces have not been penetrated. Where the Cat II OCA/H is higher than the level of the inner horizontal surface, but below 60 m, Category III operations can be accommodated provided the inner approach, inner transitional and balked landing surfaces are extended to the Cat II OCA/H level to accommodate Cat III operations (see Figure II-1-1-8 a)).

1.1.4 Obstacle clearance altitude/height (OCA/H)

1.1.4.1 The ILS criteria enable an OCA/H to be calculated for each category of aircraft. See Part I, Section 4, Chapter 1, 1.8, “Categories of aircraft”. Where statistical calculations were involved, the OCA/H values were designed against an overall safety target of 1×10^{-7} (1 in 10 million) per approach for risk of collision with obstacles.

1.1.4.2 The OCA/H ensures clearance of obstacles from the start of the final approach to the end of the intermediate missed approach segment. These criteria are based on normal operations and shall therefore not be applied for assessing the effect on safety of penetration of the Annex 14 obstacle limitation surfaces.

Note.— This OCA/H is only one of the factors to be taken into account in determining decision height as defined in Annex 6.

1.1.4.3 Additional material is included to allow operational benefit to be calculated for the improved beam holding performance of autopilots meeting national certification standards (as opposed to flight directors) in Cat II, and for improved missed approach climb performance in Cat I, II and III.

1.1.4.4 Benefit may also be calculated for aircraft with dimensions other than the standard size assumed in the basic calculations. An OCA/H is not associated with Cat III operations. These are supported by the obstacle limitation surfaces defined in Annex 14, in association with overlapping protection from the Cat II criteria.

1.1.5 Methods of calculating OCA/H

1.1.5.1 *General.* Three methods of calculating OCA/H are presented, which involve progressive increases in the degree of sophistication in the treatment of obstacles. Standard conditions (as specified in 1.1.3) are assumed to exist unless adjustments for non-standard conditions have been made.

1.1.5.2 *First method.* The first method involves a set of surfaces derived from the Annex 14 precision approach obstacle limitation surfaces and a missed approach surface described in 1.4.7.2, “Definition of basic ILS surfaces”. From this point forward, these are termed “basic ILS surfaces”. Where the standard conditions exist as specified in 1.1.3 and where the basic ILS surfaces are free of penetrations (see 1.4.7.1), the OCA/H for Cat I and Cat II is defined by aircraft category margins, and there are no restrictions on Cat III operations. If the basic ILS surfaces are penetrated, then the OCA/H is calculated as described in 1.4.7.3, “Determination of OCA/H with basic ILS surfaces”.

1.1.5.3 *Second method.* The second method involves a set of obstacle assessment surfaces (OAS) above the basic ILS surfaces (see 1.4.8.4, “Definition of obstacle assessment surfaces (OAS). If the OAS are not penetrated — and provided the obstacle density below the OAS is operationally acceptable (see 1.4.8.9, “Effect of obstacle density on OCA/H”) — the OCA/H for Cat I and Cat II is still defined by the aircraft category margins, and Cat III operations remain unrestricted. However, if the OAS are penetrated, then an aircraft category-related margin is added to the height of the highest approach obstacle, or to the adjusted height of the largest missed approach penetration, whichever is greater. This value becomes the OCA/H.

Note.— The OAS surfaces are an approximation of the mathematically derived iso-probability contours. The surfaces are simplified compared to the complex shape of the iso-probability contours. The result is that the OAS method is normally more conservative compared to the CRM method (resulting in a higher OCH). The use of the CRM in addition to the OAS may therefore provide an operational benefit. Refer to the Attachment to Part II for specific areas where these differences may affect the OCH calculation.

1.1.5.4 *Third method.* The third method, using a collision risk model (CRM), is employed either as an alternative to the use of the OAS criteria (second method) or when the obstacle density below the OAS is considered to be excessive. The CRM accepts all objects as an input and assesses, for any specific OCA/H value, both the risk due to individual obstacles and the accumulated risk due to all the obstacles. It is intended to assist operational judgement in the choice of an OCA/H value.

Note.— The CRM does not take into account the characteristics of helicopters. The CRM can be used but the method should be conservative.

1.1.6 References

The following appendices relate to and amplify the material contained in this chapter:

- a) background information relating to the derivation of the OAS material (Attachment to Part II, paragraph 1) and to airborne and ground equipment performance assumed in the derivation of the OAS (Attachment to Part II, paragraph 2);
- b) turning missed approach after precision approach (Appendix A);
- c) independent parallel approaches to closely spaced parallel runways (Appendix D);
- d) determining ILS glide path descents/MLS elevation heights and distances (Appendix C); and
- e) PANS-OPS OAS software (ICAO public website (www.icao.int) under “Publications”).

Examples of OCA/H calculations can be found in the *Instrument Flight Procedures Construction Manual* (Doc 9368).

1.1.7 ILS with glide path inoperative

The ILS with glide path inoperative is a non-precision approach procedure. The principles of Section 2, Chapter 1, “LOC only”, apply.

1.2 INITIAL APPROACH SEGMENT

1.2.1 General

The initial approach segment must ensure that the aircraft is positioned within the operational service volume of the localizer on a heading that will facilitate localizer interception. For this reason, the general criteria which apply to the initial segment (see Part I, Section 4, Chapter 3) are modified in accordance with 1.2.2, “Initial approach segment alignment” and 1.2.3, “Initial approach segment area”. The initial approach segment may be defined by an RNAV or RNP route, using an RNAV or RNP system for track guidance. Only the systems capable of navigation accuracy of 1 NM or lower in this phase of flight can be considered. Refer to Part III, Section 1, Chapter 1, Table III-1-1-1 for the navigation specifications that can be used for initial approach. The RNAV or RNP route shall terminate at an IF defined by RNAV or RNP located on the LOC course. RNAV/RNP turn construction is applicable for turns within the initial segment and for the turn at the IF on the LOC course (see Figures II-1-1-5 and II-1-1-6). For an RNAV or RNP initial approach segment, criteria in Part III apply. If a course reversal is required with an RNAV or RNP initial approach segment, only a racetrack can be used. The fix and the inbound leg shall be located on the LOC course and the inbound segment defined by the LOC.

1.2.2 Initial approach segment alignment

The angle of interception between the initial approach track and the intermediate track should not exceed 90 degrees. In order to permit the autopilot to couple on to the localizer, an interception angle not exceeding 30degrees is desirable. When the angle exceeds 70 degrees a radial, bearing, radar vector, or DME information providing at least 4 km (2 NM) (CAT H, 1.9 km (1 NM)) of lead shall be identified to assist the turn onto the intermediate track. When the angle exceeds 90 degrees, the use of a reversal, racetrack, or dead reckoning (DR) track procedure should be considered (see Part I, Section 4, Chapter 3, “Initial Approach Segment” and Part I, Section 4, Appendix A to Chapter 3, “Initial approach using dead reckoning (DR)”).

1.2.3 Initial approach segment area

The area is as described in the general criteria (see Part I, Section 4, Chapter 3, 3.3.3, “Area”). The difference is that the intermediate approach fix (IF) must be located within the service volume of the ILS localizer course signal, and normally at a distance not exceeding 46 km (25 NM) from the localizer antenna. When radar is used to provide track guidance to the IF, the area shall be in accordance with 6.2, “Initial approach segment” (Section 2, Chapter 6, “SRE”).

1.3 INTERMEDIATE APPROACH SEGMENT

1.3.1 General

1.3.1.1 The intermediate approach segment for ILS differs from the general criteria in that:

- a) the alignment coincides with the localizer course;
- b) the length may be reduced; and

c) in certain cases the secondary areas may be eliminated.

1.3.1.2 The primary and secondary areas at the FAP are defined in terms of the ILS surfaces. Consequently, the general criteria in Part I, Section 4, Chapter 4, “Intermediate Approach Segment” are applied except as modified or amplified in the paragraphs below with regards to alignment, area length and width, and for obstacle clearance. For RNAV initial approach segments, the criteria in the applicable RNAV chapters apply.

1.3.2 Intermediate approach segment alignment

The intermediate approach segment of an ILS procedure shall be aligned with the localizer course.

1.3.3 Intermediate approach segment length

1.3.3.1 The optimum length of the intermediate approach segment is 9 km (5 NM) (Cat H, 3.7 km (2.0 NM)). This segment shall allow interception with the localizer course and with the glide path.

1.3.3.2 Segment length should be sufficient to permit the aircraft to stabilize and establish on the localizer course prior to intercepting the glide path, taking into consideration the angle of interception with the localizer course.

1.3.3.3 Minimum values for distance between localizer and interception of glide path are specified in Table II-1-1-1; however, these minimum values should only be used if usable airspace is restricted. The maximum length of the segment is governed by the requirement that it be located wholly within the service volume of the localizer signal and normally at a distance not exceeding 46 km (25 NM) from the localizer antenna.

1.3.4 Intermediate approach segment area width

1.3.4.1 The total width at the beginning of the intermediate approach segment is defined by the final total width of the initial approach segment. It tapers uniformly to match the horizontal distance between the OAS X surfaces at the FAP (see 1.4.8.4, “Definition of obstacle assessment surfaces (OAS)”).

1.3.4.2 For obstacle clearance purposes the intermediate approach segment is usually divided into a primary area bounded on each side by a secondary area. However, when a DR track is used in the initial approach segment, the primary area of the intermediate approach segment extends across its full width and secondary areas are not applied.

1.3.4.3 The primary area is determined by joining the primary initial approach area with the final approach surfaces (at the FAP). At the interface with the initial approach segment the width of each secondary area equals half the width of the primary area. The secondary area width decreases to zero at the interface with the final approach surfaces. See Figures II-1-1-1, II-1-1-2 and II-1-1-3.

1.3.4.4 Where a racetrack or reversal manoeuvre is specified prior to intercepting the localizer course the provisions in Part I, Section 4, Chapter 4, 4.4.4, “Turn not at the facility” apply, the facility being the localizer itself and the FAF being replaced by the FAP. (See Figure II-1-1-4.)

1.3.5 Intermediate approach segment obstacle clearance

The obstacle clearance is the same as defined in Part I, Section 4, Chapter 4, “Intermediate approach segment” except where the procedure permits a straight-in approach in which the aircraft is stabilized on the localizer course prior to crossing the IF. In this case, obstacles in the secondary areas need not be considered for the purpose of obstacle clearance.

1.4 PRECISION SEGMENT

1.4.1 General

The precision segment is aligned with the localizer course and contains the final descent for landing as well as the initial and intermediate phases of the missed approach segment See Figure II-1-1-7.

1.4.2 Origin

The precision segment starts at the final approach point (FAP), that is, the intersection of the nominal glide path and the minimum altitude specified for the preceding segment. The FAP should not normally be located more than 18.5 km (10.0 NM) before threshold, unless adequate glide path guidance beyond the minimum specified in Annex 10 is provided.

1.4.3 Descent fix

1.4.3.1 A descent fix may be located at the FAP to overcome certain obstacles located before the FAP as an alternative to increasing the glide path (GP) angle. When so located, it becomes the final approach fix. The extension of the precision surfaces into the intermediate segment is then terminated. The descent fix should not normally be located more than 18.5 km (10.0 NM) before threshold, unless adequate GP guidance beyond the minimum specified in Annex 10 is provided. The maximum fix tolerance is ± 0.9 km (± 0.5 NM). Where DME is used to identify the fix, the range shall be stated in tenths of kilometres (nautical miles).

Note.— Guidance material for determining the distance to the descent fix from the threshold is contained in Appendix C.

1.4.3.2 *Obstacle clearance at the descent fix.* When a descent fix is provided, the precision approach surfaces start at the earliest point of the FAF tolerance area (see Figure II-1-1-2). The provisions of Part I, Section 2, Chapter 2, 2.7.4, “Obstacle close to a final approach fix or stepdown fix” which allow obstacles close to the fix to be ignored, apply in the area below the 15 per cent gradient within the precision surfaces (Cat H, 15 per cent gradient or the nominal gradient multiplied by 2.5, whichever is greater). Where a descent fix is not provided at the FAP, no curtailment of the precision surfaces is permitted (see Figure II-1-1-3). If the precision surfaces are extended into the preceding segment, they shall not be extended beyond the intermediate approach segment.

1.4.4 Glide path verification check

A fix (outer marker or DME) is necessary so as to permit comparison between the indicated glide path and the aircraft altimeter information. The fix shall not have a fix tolerance exceeding ± 0.9 km (± 0.5 NM). When DME is used to identify the fix, the range shall be stated in tenths of kilometres (nautical miles).

Note.— Guidance material for determining the height crossing the outer marker is contained in Appendix C.

1.4.5 Missed approach

The missed approach point is defined by the intersection of the nominal glide path and the decision altitude/height (DA/H). The DA/H is set at or above the OCA/H, which is determined as specified in 1.4.7 to 1.4.9 and 1.5.

1.4.6 Termination

The precision segment normally terminates at the point where the final phase of the missed approach commences (see Part I, Section 4, Chapter 6, 6.1.2, “Phases of missed approach segment”) or where the missed approach climb surface Z (starting 900 m past threshold) reaches a height of 300 m (984 ft) above threshold, whichever is lower.

1.4.7 Obstacle clearance of the precision segment application of basic ILS surfaces

1.4.7.1 *General.* The area required for the precision segment is bounded overall by the basic ILS surfaces defined in 1.4.7.2, below. In standard conditions there is no restriction on objects beneath these surfaces (see 1.1.3, “Standard conditions”). Objects or portions of objects that extend above these surfaces must be either:

- a) minimum mass and frangible; or
- b) taken into account in the calculation of the OCA/H.

1.4.7.2 *Definition of basic ILS surfaces.* The surfaces to be considered correspond to a subset of Annex 14 obstacle limitation surfaces as specified for precision approach runway code numbers 3 or 4 (see Figure II-1-1-8 b)). These are:

- a) the approach surface continuing to the final approach point (FAP) (first section 2 per cent gradient, second section 2.5 per cent as described in Annex 14);
- b) the runway strip assumed to be horizontal at the elevation of the threshold;
- c) the missed approach surface. This is a sloping surface which:
 - 1) starts at a point 900 m past the threshold (Cat H, a starting point of 700 m past the threshold can be considered if necessary) at threshold elevation;
 - 2) rises at a 2.5 per cent gradient; and
 - 3) splays so as to extend between the transitional surfaces. It extends with constant splay to the level of the inner horizontal surface. Thereafter, it continues at the same gradient but with a 25 per cent splay until the termination of the precision segment; and
- d) the extended transitional surfaces, which continue longitudinally along the sides of the approach and missed approach surfaces and up to a height of 300 m above threshold elevation.

1.4.7.3 Determination of OCA/H with basic ILS surfaces

1.4.7.3.1 Where the basic ILS surfaces specified in 1.4.7.2 are not penetrated, the OCA/H for Category I and Category II is defined by the margins specified in Table II-1-1-2, and Category III operations are not restricted. Obstacles may be excluded when they are below the transitional surface defined by Annex 14 for runways with code numbers 3 and 4, regardless of the actual runway code number (i.e., the surfaces for code numbers 3 and 4 are used for the obstacle assessment on runways with code numbers 1 and 2).

1.4.7.3.2 If the basic ILS surfaces listed above are penetrated by objects other than those listed in Table II-1-1-3, the OCA/H may be calculated directly by applying height loss/altimeter margins to obstacles (see 1.4.8.8, “Determination of OCA/H with OAS or basic ILS surfaces”).

1.4.7.3.3 The obstacles in Table II-1-1-3 may only be exempted if the following two criteria are met:

- a) the localizer course sector has the standard width of 210 m (see 1.1.3, “Standard conditions”); and
- b) the Category I decision height is not less than 60 m (200 ft) or the Category II decision height is not less than 30 m (100 ft).

1.4.7.3.4 An object that penetrates any of the basic ILS surfaces and becomes the controlling obstacle, but must be maintained because of its function with regards to air navigation requirements, may be ignored under certain circumstances in calculating the OCA/H, with the following provision. It must be established by the appropriate authority that the portion which penetrates the surface is of minimum mass and frangibly mounted and would not adversely affect the safety of aircraft operations.

1.4.8 Obstacle clearance of the precision segment using obstacle assessment surface (OAS) criteria

1.4.8.1 General

1.4.8.1.1 This section describes the OAS surfaces, the constants which are used to define these surfaces, and the conditions under which adjustments may or must be made. The OAS dimensions are related to:

- a) the ILS geometry (localizer-threshold distance, glide path angle, ILS RDH, localizer sector width);
- b) the category of ILS operation; and
- c) other factors, including aircraft geometry, missed approach climb gradient.

Thus, a table of OCA/H values for each aircraft category may be calculated for Cat I and II ILS operations at the particular airfield.

1.4.8.1.2 Additional material is included to enable appropriate authorities to assess realistic benefits for claims of improved performance and associated conditions. See 1.4.8.7, “Adjustment of OAS constants”.

1.4.8.1.3 Note that the OAS are not intended to replace Annex 14 surfaces as planning surfaces for unrestricted obstacle growth. The obstacle density between the basic ILS surfaces and the OAS must be accounted for (see 1.4.8.9, “Effect of obstacle density on OCA/H”).

1.4.8.2 Frame of reference

Positions of obstacles are related to a conventional x, y, z coordinate system with its origin at threshold. See Figure II-1-1-12. The x-axis is parallel to the precision segment track: positive x is distance before threshold and negative x is distance after threshold. The y-axis is at right angles to the x-axis. Although shown conventionally in Figure II-1-1-12, *in all calculations associated with OAS geometry, the y coordinate is always counted as positive*. The z-axis is vertical, heights above threshold being positive. All dimensions connected with the OAS are specified in metres only. The dimensions should include any adjustments necessary to cater for tolerances in survey data (see Part I, Section 2, Chapter 1, 1.9, “Charting accuracy”).

1.4.8.3 OAS constants — specification

For Category I and II operations the constants A, B and C for each sloping surface are obtained from the PANS-OPS OAS software (ICAO public website (www.icao.int) under “Publications”). The PANS-OPS OAS software gives

coefficients for glide path angles between 2.5 and 3.5 degrees in 0.1 degree steps, and for any localizer-threshold distance between 2 000 m and 4 500 m. Extrapolation outside these limits is not permitted. If a localizer threshold distance outside this range is entered, the PANS-OPS OAS software gives the coefficients for 2 000 m or 4 500 m as appropriate, which must be used. For an example of the PANS-OPS OAS software results see Figure II-1-1-14.

1.4.8.4 Definition of obstacle assessment surfaces (OAS)

1.4.8.4.1 The OAS consist of six sloping plane surfaces (denoted by letters W, X, Y, and Z) arranged symmetrically about the precision segment track, together with the horizontal plane which contains the threshold (see Figures II-1-1-10 and II-1-1-11). The geometry of the sloping surfaces is defined by four linear equations of the form $z = Ax + By + C$. In these equations x and y are position coordinates and z is the height of the surface at that position (see Figure II-1-1-9).

1.4.8.4.2 For each surface a set of constants (A, B and C) are obtained from the PANS-OPS OAS software for the operational range of localizer threshold distances and glide path angles. Separate sets of constants are specified for Category I and II. These constants may be modified by the programme (see 1.4.8.7, “Adjustment of OAS constants”).

1.4.8.4.3 The Category I OAS are limited by the length of the precision segment and, except for the W and X surfaces, by a maximum height of 300 m. The Category II OAS are limited by a maximum height of 150 m.

1.4.8.4.4 Where the Annex 14 approach and transitional obstacle limitation surfaces for code numbers 3 and 4 precision approach runways penetrate inside the OAS, the Annex 14 surfaces become the OAS (i.e. the surfaces for code numbers 3 and 4 are used for obstacle assessment on runways with code numbers 1 and 2). The Annex 14 inner approach, inner transitional and balked landing obstacle limitation surfaces protect Category III operations, provided the Category II OCA/H is at or below the top of those surfaces which may be extended up to 60 m if necessary) (see Figure II-1-1-8 a)).

1.4.8.5 Calculation of OAS heights

To calculate the height z of any of the sloping surfaces at a location x' , y' , the appropriate constants should be first obtained from the PANS-OPS OAS software. These values are then substituted in the equation $z = Ax' + By' + C$. If it is not clear which of the OAS surfaces is above the obstacle location this should be repeated for the other sloping surfaces. The OAS height is the highest of the plane heights (zero if all the plane heights are negative).

Note.— The PANS-OPS OAS software also contains an OCH calculator that will show the height of the OAS surface z above any x , y location. It includes all the adjustments specified for ILS geometry, aircraft dimensions, missed approach climb gradient and ILS reference datum height.

1.4.8.6 OAS template construction

1.4.8.6.1 Templates, or plan views of the OAS contours to map scale, are sometimes used to help identify obstacles for detail survey (see Figure II-1-1-13). The OAS data in the PANS-OPS software include the coordinates of the points of intersection:

- a) of the sloping surfaces at threshold level. The intersection coordinates are labeled as C, D and E (Figure II-1-1-11);
- b) at 300 m above threshold level for Cat I; and
- c) at 150 m for Cat II.

1.4.8.7 Adjustment of OAS constants

1.4.8.7.1 *General.* The following paragraphs describe the adjustments that the PANS-OPS OAS software programme makes to the OAS constants. These adjustments are mandatory when the standard conditions are not met (see 1.1.3, “Standard conditions”). Optional adjustments may be made when so specified. For examples of calculations see the Instrument Flight Procedures Construction Manual (Doc 9368).

1.4.8.7.2 *Reasons for adjusting constants.* The constants may be modified to account for the following:

- a) missed approach climb gradient (see 1.4.8.7.7, below);
- b) dimensions of specific aircraft (see 1.4.8.7.3, below);
- c) the height of the ILS reference datum (see 1.4.8.7.4, below);
- d) improved beam holding performance due to use of autopilots certified for Category II operations (see 1.4.8.7.6, below); and
- e) certain Category I localizers having a sector width greater than the nominal 210 m at threshold (see 1.4.8.7.5, below).

1.4.8.7.3 *Specific aircraft dimensions.* An adjustment is mandatory where aircraft dimensions exceed those specified in 1.1.3, “Standard conditions” and is optional for aircraft with smaller dimensions. The PANS-OPS OAS software adjusts the OAS coefficients and template coordinates for the standard dimensions of Category A, B, C, D and D_L aircraft automatically. It will do the same for specific aircraft dimensions in any category. It uses the following correction formula to adjust the coefficient C for the W, W*, X and Y surfaces:

$$\text{W surface: } C_{w\text{corr}} = C_w - (t - 6)$$

$$\text{W* surface: } C_{w^*\text{corr}} = C_{w^*} - (t - 6)$$

$$\text{X surface: } C_{x\text{corr}} = C_x - B_x \cdot P$$

$$\text{Y surface: } C_{y\text{corr}} = C_y - B_y \cdot P$$

where: $P = \left[\frac{t}{B_x} \text{ or } S + \frac{t-3}{B_x}, \text{ whichever is the maximum} \right] - \left[\frac{6}{B_x} \text{ or } 30 + \frac{3}{B_x}, \text{ whichever is the maximum} \right]$

and

s = semi-span

t = vertical distance between paths of the GP antenna and the lowest part of the wheels.

1.4.8.7.4 *Height of the ILS reference datum (RDH).* This is based on a reference datum height (RDH) of 15 m. An adjustment to the OAS constants is mandatory for an RDH less than 15 m, and is optional for an RDH greater than 15 m. The PANS-OPS OAS software adjusts the OAS coefficients and template coordinates by correcting the tabulated values of the coefficient C for the W, W*, X and Y surfaces as follows:

$$C_{\text{corr}} = C + (\text{RDH} - 15)$$

where: C_{corr} = corrected value of coefficient C for the appropriate surface

C = tabulated value.

1.4.8.7.5 *Modification for Cat I localizers with course width greater than 210 m at threshold.* Where the ILS localizer sector width at threshold is greater than the nominal value of 210 m, the collision risk model (CRM) method described in 1.4.9 shall be used. Adjustments for sector widths less than 210 m shall not be made, and are inhibited in the PANS-OPS OAS software.

1.4.8.7.6 *Use of autopilot (autocoupled) in Cat II.* The Cat II OAS may be reduced to reflect the improved beam holding of autopilots where these are certificated for the operation by the appropriate authority. This reduction is achieved in the PANS-OPS OAS software by the use of modified A, B and C constants for the X surface, and the introduction of an extra surface (denoted by W*) (see Figure II-1-1-13 c)). The use of these reduced surfaces should not be authorized for non-autocoupled approaches.

1.4.8.7.7 *Missed approach climb gradient.* If equipment is capable of missed approach climb gradients better than the nominal 2.5 per cent, the Y and Z surfaces may be adjusted. This is done by using the desired missed approach climb gradient in the PANS-OPS OAS software. The programme then adjusts the Y and Z surface coefficients.

1.4.8.8 *Determination of OCA/H with OAS or basic ILS surfaces*

1.4.8.8.1 *General.* The OCA/H is determined by accounting for all obstacles which penetrate the basic ILS surfaces defined in 1.4.7.2 and the OAS surfaces applicable to the ILS category of operation being considered. The exemptions listed in 1.4.7.3, “Determination of OCA/H with basic ILS surfaces” for obstacles penetrating the basic ILS surfaces may be applied to obstacles penetrating the OAS, providing the criteria listed in that paragraph are met. The surfaces which apply to each category of operations are:

- a) *ILS Cat I:* ILS Cat I OAS;
- b) *ILS Cat II:* ILS Cat II OAS and those portions of ILS Cat I which lie above the limits of ILS Cat II; and
- c) *ILS Cat III:* Same as ILS Cat II.

1.4.8.8.2 *Calculation of OCA/H values with OAS.* Accountable obstacles, as determined below in 1.4.8.8.2.1, “OCA/H Calculation steps” are divided into approach and missed approach obstacles. The standard method of categorization is as follows: Approach obstacles are those between the FAP and 900 m after threshold (Cat H, 700 m if necessary). Missed approach obstacles are those in the remainder of the precision segment (see Figure II-1-1-15). However, in some cases this categorization of obstacles may produce an excessive penalty for certain missed approach obstacles (see Attachment to Part II, 1.9). Where desired by the appropriate authority, missed approach obstacles may be defined as those above a plane surface parallel to the plane of the glide path and with origin at –900 m (Cat H, –700 m if necessary) (see Figure II-1-1-16), i.e. obstacle height greater than $[(900 + x) \tan\theta]$.

1.4.8.8.2.1 *OCA/H Calculation steps*

- a) Determine the height of the highest approach obstacle.
- b) Convert the heights of all missed approach obstacles (h_{ma}) to the heights of equivalent approach obstacles (h_a) by the formula given below, and determine the highest equivalent approach obstacle.
- c) Determine which of the obstacles identified in steps a) and b) is the highest. This is the controlling obstacle.
- d) Add the appropriate aircraft category related margin (Table II-1-1-2) to the height of the controlling obstacle.

$$h_a = \frac{h_{ma} \cot Z + (x_z + x)}{\cot Z + \cot\theta}$$

where:

h_a	=	height of equivalent approach obstacle
h_{ma}	=	height of missed approach obstacle
θ	=	angle of glide path (elevation angle)
Z	=	angle of missed approach surface
x	=	range of obstacle relative to threshold (negative after threshold)
x_z	=	distance from threshold to origin of Z surface (900 m (700 m Cat H))

1.4.8.8.3 Adjustment for high airfield elevations and steep glide path angles

1.4.8.8.3.1 *Height loss (HL)/altimeter margins.* The margins in Table II-1-1-2 shall be adjusted as follows:

- for airfield elevation higher than 900 m (2 953 ft), the tabulated allowances shall be increased by 2 per cent of the radio altimeter margin per 300 m (984 ft) airfield elevation; and
- for glide path angles greater than 3.2° in exceptional cases, the allowances shall be increased by 5 per cent of the radio altimeter margin per 0.1° increase in glide path angle between 3.2° and 3.5°.

1.4.8.8.3.1.1 Procedures involving glide paths greater than 3.5° or any angle when the nominal rate of descent (V_{at} for the aircraft type \times the sine of the glide path angle) exceeds 5 m/sec (1 000 ft/min), are non-standard. They require the following:

- increase of height loss margin (which may be aircraft type specific);
- adjustment of the origin of the missed approach surface;
- adjustment of the slope of the W surface;
- re-survey of obstacles; and
- the application of related operational constraints.

Such procedures are normally restricted to specifically approved operators and aircraft, and are associated with appropriate aircraft and crew restrictions. They are not to be used as a means to introduce noise abatement procedures.

1.4.8.8.3.1.2 Appendix B shows the procedure design changes required and the related operational/certification considerations.

Example: Aircraft Category C — Aerodrome elevation: 1 650 m above MSL; glide path angle 3.5°.

Tabulated allowances: radio altimeter 22 m

(Table II-1-1-2) pressure altimeter 46 m

Correction for aerodrome elevation:

$$22 \times \frac{2}{100} \times \frac{1\,650}{300} = 2.42 \text{ m}$$

Correction for glide path angle:

$$22 \times \frac{5}{100} \times \frac{3.5-3.2}{0.1} = 3.30 \text{ m}$$

Total correction 5.72 m rounded up to 6 m.

Corrected radio altimeter margin $22 + 6 = 28$ m.

Corrected pressure altimeter margin $46 + 6 = 52$ m.

1.4.8.8.3.2 *Exceptions and adjustments to values in Table II-1-1-2.* Values in Table II-1-1-2 are calculated to account for aircraft using normal manual overshoot procedures from OCA/H on the nominal approach path. The values in Table II-1-1-2 do not apply to Cat III operations. The values do not consider the lateral displacement of an obstacle nor the probability of an aircraft being so displaced. If consideration of these joint probabilities is required, then the CRM discussed in 1.4.9 shall be used. Values in Table II-1-1-2 may be adjusted for specific aircraft types where adequate flight and theoretical evidence is available, i.e. the height loss value corresponding to a probability of 1×10^{-5} (based on a missed approach rate 10^{-2}).

1.4.8.8.3.3 *Radio altimeter verification.* If the radio altimeter OCA/H is promulgated, operational checks shall have confirmed the repeatability of radio altimeter information.

1.4.8.8.3.4 *Height loss (HL)/altimeter margins for a specific speed at threshold.* If a height loss/altimeter margin is required for a specific V_{at} , the following formulae apply (see also Table II-1-1-4):

Use of radio altimeter:

Margin = $(0.096 V_{at} - 3.2)$ metres where V_{at} in km/h

Margin = $(0.177 V_{at} - 3.2)$ metres where V_{at} in kt

Use of pressure altimeter:

Margin = $(0.068 V_{at} + 28.3)$ metres where V_{at} in km/h

Margin = $(0.125 V_{at} + 28.3)$ metres where V_{at} in kt

where V_{at} is the speed at threshold based on 1.3 times stall speed in the landing configuration at maximum certificated landing mass.

Note.— The equations assume the aerodynamic and dynamic characteristics of the aircraft are directly related to the speed category. Thus, the calculated height loss/altimeter margins may not realistically represent small aircraft with V_{AT} at maximum landing mass exceeding 165 kt.

1.4.8.8.3.5 *Height loss (HL)/altimeter margins for a specific speed at threshold (Helicopters).* For helicopter operations the concept of V_{at} is not applicable. Height loss margins are listed in Table II-1-1-2.

1.4.8.9 *Effect of obstacle density on OCA/H.* To assess the acceptability of obstacle density below the OAS, the CRM described in 1.4.9 may be used. This can provide assistance by comparing aerodrome environments and by assessing risk levels associated with given OCA/H values. It is emphasized that it is not a substitute for operational judgement.

1.4.9 Obstacle clearance of the precision segment — application of collision risk model (CRM)

1.4.9.1 *General.* The CRM is a computer programme that establishes the numerical risk which can be compared to the target level of safety for aircraft operating to a specified OCA/H height. A description of the programme and instructions on its use, including the precise format of both the data required as input and the output results, are given in the *Manual on the Use of the Collision Risk Model (CRM) for ILS Operations* (Doc 9274).

1.4.9.2 *Input.* The CRM requires the following data as input:

- a) *aerodrome details:* name, runway threshold position and runway orientation in threshold elevation above MSL, details of proceeding segment;
- b) *ILS parameters:* category, glide slope angle, localizer-threshold distance, localizer course width, height of ILS reference datum above threshold;
- c) *missed approach parameters:* decision height (obstacle clearance height) and missed approach turn point;
- d) *aircraft parameters:* type, wheel height (antenna to bottom of wheel), and wing semi-span, aircraft category (A, B, C, D or D_L) and missed approach climb gradient; and

Note.— The CRM does not consider Category E aircraft.

- e) *obstacle data:* obstacle boundaries (either as x and y coordinates relative to the runway threshold or as map grid coordinates) and obstacle height (either above threshold elevation or above MSL). For density assessment, all obstacles penetrating the basic ILS surfaces described in 1.4.7.2 must be included.

1.4.9.3 *Output and application.* The output of the programme is:

- a) the overall (total) risk of collision with obstacles for aircraft operating to a specified OCA/H; and
- b) the minimum OCA/H which will provide the target level of safety.

The user, by rerunning the CRM with the appropriate parameters, can assess the effect on the safety of operations of any alteration in the parameters, typically varying the glide path angle or remaining obstacles.

1.5 MISSED APPROACH SEGMENT

1.5.1 General

1.5.1.1 The criteria for the final missed approach are based on those for the general criteria (see Part I, Section 4, Chapter 6). Certain modifications have been made to allow for the different areas and surfaces associated with the precision segment and for the possible variation in OCA/H for that segment with aircraft category. Area construction is according to the navigation system specified for the missed approach.

1.5.1.2 The datum used for calculation of distances and gradients in obstacle clearance calculations is termed “start of climb” (SOC). It is defined by the height and range at which the plane GP’— a plane parallel with the glide path and with origin at –900 m (Cat H, –700 m) at threshold level — reaches the altitude OCA/H – HL. OCA/H and HL must both relate to the same category of aircraft.

1.5.1.3 If obstacles identified in the final missed approach segment result in an increase in any of the OCA/H calculated for the precision segment, a higher gradient of the missed approach surface (Z) may be specified in addition if this will provide clearance over those obstacles at a specified lower OCA/H (see Part I, Section 4, Chapter 6, 6.2.3.1, “Climb gradient in the final phase”).

1.5.1.4 A missed approach can be based on RNAV or RNP navigation specifications. Only the systems capable of navigation accuracy of 1 NM or better in this phase of flight can be considered. Refer to Part III, Section 1, Chapter 1, Table III-1-1-1 for the navigation specifications that can be used for missed approach.

1.5.2 Straight missed approach

1.5.2.1 *General.* The precision segment terminates at the point where the Z surface reaches a height 300 m above threshold. The width of the Z surface at that distance defines the initial width of the final missed approach area which splays at an angle of 15 degrees from that point, as shown in Figure II-1-1-17. There are no secondary areas.

1.5.2.2 *Straight missed approach obstacle clearance.* (See Figure II-1-1-18.) Obstacle elevation/height in this final missed approach area shall be less than

$$(OCA/H_{ps} - HL) + d_o \tan Z$$

where:

- a) OCA/H of the precision segment (OCA/H_{ps}) and HL (Table II-1-1-2 value) both relate to the same aircraft category.
- b) d_o is measured from SOC parallel to the straight missed approach track; and
- c) Z is the angle of the missed approach surface with the horizontal plane.

If this requirement cannot be met, a turn shall be prescribed to avoid the obstacle in question. If a turn is not practical, the OCA/H shall be raised.

1.5.2.3 Transition from conventional navigation to an RNAV or RNP missed approach may be defined by an RNAV or RNP fix located on the extended LOC course, or by a turn at an altitude direct to a waypoint (see Figure II-1-1-23). If the RNAV or RNP track is collinear with the LOC course, the area abeam the SOC shall be expanded at a 15 degree angle from the track course until it reaches the applicable width of the RNAV or RNP area constructed on the extended LOC course. In the region between the lateral boundaries of the Z surface and the outer boundaries of the area, the obstacle evaluation shall be based on the Y surface and a mathematical extrapolation of the Y surface where the area is outside the lateral boundaries of the OAS 300 m contour. The Z surface shall continue to splay at the same angle until reaching the width of the RNAV or RNP area. Secondary areas shall apply from the point where the width of Z surface reaches the width of RNAV or RNP primary area (see Figure II-1-1-21). Obstacle clearance up to this point for the extended Y and Z surfaces shall be the same as in the precision segment (see 1.4.8 “Obstacle clearance of the precision segment using obstacle assessment surface (OAS) criteria”), and this shall also apply further out to all portions of the Z surface that are within the RNAV or RNP primary area. The principle of secondary areas shall apply between the edge of the RNAV or RNP primary area and the edge of the total area. If an obstacle penetrates either the extended Y or the Z surface within the secondary area, its elevation/height shall be less than:

$$(OCA/H_{ps} - HL) + d_o \tan Z + M$$

where:

- a) OCA/H of the precision segment (OCA/H_{ps}) and HL (Table II-1-1-2 value) both relate to the same aircraft category;
- b) d_o is measured from SOC parallel to the straight missed approach track;
- c) Z is the angle of the missed approach surface with the horizontal plane; and
- d) M is zero at the edge of the primary area increasing linearly to 30 m (98 ft) at the edge of the total area.

1.5.3 Turning missed approach

1.5.3.1 *General.* Turns may be prescribed at a designated turning point (TP), at a designated altitude/height, or “as soon as practicable”. The criteria used depend on the location of the turn relative to the normal termination of the precision segment (see 1.4.6, “Termination”) and are as follows:

- a) *turn after normal termination of the precision segment.* If a turn is prescribed after normal termination of the precision segment, the general criteria of Part I, Section 4, Chapter 6, 6.4.5, “Turn initiated at a designated altitude/height” and Part I, Section 4, Chapter 6, 6.4.6, “Turn initiated at a designated turning point” apply with the following exceptions:
 - 1) OCA/H is replaced by (OCA/H – HL) as in 1.5.2.2, “Straight missed approach obstacle clearance”; and
 - 2) because SOC is related to OCA/H, it is not possible to obtain obstacle clearance by the means used in non-precision approaches (that is, by independent adjustment of OCA/H or MAPt);
- b) *turn before normal termination of the precision segment.* If a turn is prescribed at a designated altitude/height which is less than 300 m above threshold, or at a designated TP such that the earliest TP is within the normal termination range, the criteria specified in 1.5.3.2 and 1.5.3.3 below shall be applied;
- c) for missed approaches using RNAV or RNP, fly-by or flyover turns should be limited to 90 degrees. RF turns are not permitted as the first RNP leg of the missed approach since there would be no tangent RNP entry track specified. In this case, a TF leg with the first waypoint located on the extended LOC course is required preceding the RF leg;
- d) the earliest location of the first RNAV or RNP fix is at a distance of ATT after the SOC (see Figure II-1-1-24). If the fix designates a fly-by turn, the additional distance $d_1 + 3V/3 600$, where V is the TAS shall be added prior to the fix ($d_1 = r \tan A/2$); and
- e) for an RNAV or RNP missed approach, RNAV/RNP turn construction and turning MOC (50 m (164 ft) for turns of more than 15 degrees and 30 m (98 ft) for all other turns) shall apply after the earliest turning point. Secondary areas shall apply between the standard width of the RNAV or RNP primary area and the edge of the total area, except that obstacles located under the Y surface or its extension on the outer side of the turn need not be considered. See Figures II-1-1-21 and II-1-1-22.

Note.— Adjustments to designated TP location or to the designated turn altitude may involve redrawing the associated areas and recalculating the clearances. This can exclude some obstacles or introduce new ones. Thus, when it is necessary to obtain the minimum value of OCA/H – particularly when constraints due to obstacles are very high – it may be necessary to adjust the designated TP or turn altitude by trial and error. (See Appendix A).

1.5.3.2 Turn at a designated altitude/height less than 300 m above threshold

1.5.3.2.1 The general criteria apply (see Part I, Section 4, Chapter 6, 6.4.5, “Turn initiated at a designated altitude/height”) as amplified and modified by the contents of this section. Construction of the turn initiation area and the subsequent turn are illustrated in Figure II-1-1-19.

1.5.3.2.2 Turn altitude/height

The general criteria apply, modified as follows. The precision segment terminates (and the final missed approach segment begins) at the TP. This allows the calculation of OCA/H_{ps} and $(OCA/H_{ps} - HL)$. SOC is then determined, and turn altitude/height (TNA/H) is computed from the following relationship:

$$TNA/H = OCA/H_{ps} - HL + d_z \tan Z$$

where: d_z is the horizontal distance from SOC to the TP and

OCA/H_{ps} = OCA/H calculated for the precision segment.

If the TP is located at the SOC, the chart shall be annotated “turn as soon as practicable to ... (heading or facility)” and shall include sufficient information to identify the position and height of the obstacles dictating the turn requirement.

1.5.3.2.3 Areas

1.5.3.2.3.1 *Turn initiation area.* (See Figure II-1-1-19). The turn initiation area is bounded by the 300 m Category I Y surface contour, and terminates at the TP.

Note.— *The earliest TP is considered to be at the beginning of the 300 m Category I Y surface contour (point D) unless a fix is specified to limit early turns (see 1.5.3.2.6, “Safeguarding of early turns”).*

1.5.3.2.3.2 *Turn boundary construction.* Turn boundaries are constructed as specified in Section 2, Chapter 3, “Turn area construction”

1.5.3.2.4 Obstacle clearance

a) *Obstacle clearance in the turn initiation area.* Obstacle elevation/height in the turn initiation area shall be less than:

- 1) turn altitude/height – 50 m (164 ft) (Cat H, 40 m (132 ft)) for turns more than 15°; and
- 2) turn altitude/height – 30 m (98 ft) for turns 15° or less,

except that obstacles located under the Y surface on the outer side of the turn need not be considered when calculating turn altitude/height.

b) *Obstacle clearance in the turn area.* Obstacle elevation/height in the turn area and subsequently shall be less than:

turn altitude/height + $d_o \tan Z$ – MOC

where d_o is measured from the obstacle to the nearest point on the turn initiation area boundary and MOC is:

- 1) 50 m (164 ft) (Cat H, 40 m (132 ft)) for turns more than 15°; and
- 2) 30 m (98 ft) for turns 15° or less,

reducing linearly to zero at the outer edge of the secondary areas, if any.

1.5.3.2.5 *Turn altitude/height adjustments.* If the criteria specified in 1.5.3.2.4, “Obstacle clearance”, above cannot be met, the turn altitude/height shall be adjusted. This can be done in two ways:

- a) *adjust turn altitude/height without changing OCA/H:* this means that the TP will be moved and the areas redrawn accordingly; and
- b) *raise turn altitude/height by increasing OCA/H:* this results in a higher turn altitude over the same TP. The turn areas remain unchanged.

1.5.3.2.6 *Safeguarding of early turns.* Where the published procedure does not specify a fix to limit turns for aircraft executing a missed approach from above the designated turn altitude/height, an additional check of obstacles shall be made. The general criteria of Part I, Section 4, Chapter 6, 6.4.5.6, “Safeguarding of early turns” and general principles of Part I, Section 4, Chapter 6, Figure I-4-6-14 apply with the following modifications:

- a) the limit of the final approach area is replaced by the line DD” of the OAS surfaces and its extension;
- b) the FAF is replaced by the FAP;
- c) the earliest MAPt is replaced by the line D”D” (earliest limit of the turn initiation area); and
- d) if the criterion cannot be met, then the procedure must prohibit turns before a point equivalent to the MAPt and a note must be added on the profile view of the approach chart.

1.5.3.3 *Turn at a designated TP with earliest TP before normal termination of precision segment*

1.5.3.3.1 Where a turn is specified at a designated TP, and the earliest TP is before the normal termination range of the precision segment, the precision segment terminates at the earliest TP. This allows the calculation of OCA/H_{ps} and $(OCA/H_{ps} - HL)$; SOC is then determined.

1.5.3.3.2 *Turn area.* The turn area is constructed as specified in Part I, Section 4, Chapter 6, 6.4.6.3, “Construction of the turn area” except that it is based on the width of the 300 m OAS Y surface contours at the earliest and latest TP (see Figure II-1-1-20).

1.5.3.3.3 *Obstacle clearance.* Obstacle elevation/height shall be less than:

$$(OCA/H_{ps} - HL) + d_o \tan Z - MOC$$

where: d_o = d_z + shortest distance from obstacle to line K-K,
 d_z = horizontal distance from SOC to the earliest TP,

and MOC is:

50 m (164 ft) (Cat H, 40 m (132 ft)) for turns more than 15° and

30 m (98 ft) for turns 15° or less.

If the obstacle elevation/height exceeds this value, the OCA/H must be increased, or the TP moved to obtain the required clearance (see Appendix A).

1.6 SIMULTANEOUS PRECISION APPROACHES TO PARALLEL OR NEAR-PARALLEL INSTRUMENT RUNWAYS

Note.— *Guidance material is contained in the Manual on Simultaneous Operations on Parallel or Near-Parallel Instrument Runways (Doc 9643).*

1.6.1 General

When it is intended to use precision approach procedures to parallel runways simultaneously, the following additional criteria shall be applied in the design of both procedures:

- a) the maximum intercept angle with the final approach course is 30°. The point of intercepting final approach course should be located at least 3.7 km (2.0 NM) prior to the point of intercepting the glide path;
- b) the minimum altitudes of the intermediate approach segments of the two procedures differ by at least 300 m (1 000 ft); and
- c) the nominal tracks of the two missed approach procedures diverge by at least 30°. Associated missed approach turns shall be specified as “as soon as practicable”.

1.6.2 Obstacle clearance

The obstacle clearance criteria for precision approaches, as specified in the designated chapters apply for each of the parallel precision procedures. In addition to these criteria, a check of obstacles shall be made in the area on the far side of the parallel runway in order to safeguard early turns required to avoid potential intruding aircraft from the adjacent runway. This check can be made using a set of separately defined parallel approach obstacle assessment surfaces (PAOAS). An example of a method to assess obstacles for these procedures is included in Appendix D.

1.7 PROMULGATION

1.7.1 General

1.7.1.1 The general criteria in Part I, Section 2, Chapter 1, 1.12, “Promulgation” apply as amplified by criteria in Part III, Section 2, Chapter 5 and Section 5, Chapter 1. The instrument approach chart for an ILS approach procedure shall be identified by the title ILS Rwy XX. If CAT II and/or III minima are included on the chart, the title shall read ILS Rwy XX CAT II or ILS Rwy XX CAT II & III, as appropriate. If more than one ILS procedure is published for the same runway, the Duplicate Procedure Title convention shall be applied. An example where the convention is applied is two ILS procedures with different segments, such as different missed approach segments.

1.7.1.2 When a final approach fix is identified at the FAP, a warning shall be appended to the procedure stating that descent on the glidepath below the FAF altitude is not permitted until passing the FAF.

1.7.2 Promulgation of OCA/H values

1.7.2.1 Promulgation of OCA/H for Cat I and II approach procedures

1.7.2.1.1 The OCA or OCH values, as appropriate, shall be promulgated for those categories of aircraft for which the procedure is designed. The values shall be based on the following standard conditions:

- a) Cat I flown with pressure altimeter;
- b) Cat II flown autocoupled with radio altimeter;
- c) standard aircraft dimensions (see 1.1.3, “Standard conditions”); and
- d) 2.5 per cent missed approach climb gradient.

1.7.2.1.2 Additional values of OCA/H may be agreed upon between operators and the appropriate authority and be promulgated, provided that modifications have been carried out using the guidelines and algorithms defined in 1.4.8.7, “Adjustment of OAS constants”.

1.7.2.1.3 Use of OCA/H values for Category I approach procedures based on radio altimeter height loss margins may be agreed upon between operators and the appropriate authority, and the values promulgated, if the requirement of 1.4.8.8.3.3, “Radio altimeter verification” is met.

1.7.2.2 Promulgation of Category III approach procedures

Category III operations may be permitted subject to the appropriate Category II OCA/H being below the height of the Annex 14 inner horizontal surface. Category III operations may also be permitted with a Category II OCA/H between the height of the inner horizontal surface and 60 m provided the Annex 14 Category II inner approach, inner transitional and balked landing surfaces are extended to protect that OCA/H.

1.7.3 Turn at a designated altitude/height (missed approach)

If the TP is located at the SOC, the chart shall be annotated “turn as soon as practicable to ... (heading or facility)” and shall include sufficient information to identify the position and height of the obstacles dictating the turn requirement.

1.7.4 Turn at a designated TP (missed approach)

Where the procedure requires that a turn be executed at a designated TP, the following information must be published with the procedure:

- a) the TP, when it is designated by a fix; or
- b) the intersecting VOR radial, NDB bearing, or DME distance where there is no track guidance (see Part I, Section 2, Chapter 2, 2.6.5, “Missed approach fixes”).

1.7.5 Procedures involving non-standard glide path angles

Procedures involving glide paths greater than 3.5° or any angle when the nominal rate of descent exceeds 5 m/sec (1 000 ft/min), are non-standard and subject to restrictions (see 1.4.8.8.3.1, “Height loss (HL)/altimeter margins”). They are normally restricted to specifically approved operators and aircraft, and are promulgated with appropriate aircraft and crew restrictions annotated on the approach chart.

1.7.6 Additional gradient for the final missed approach segment

If obstacles identified in the final missed approach segment result in an increase in any of the OCA/H calculated for the precision segment, a higher gradient of the missed approach surface (Z) may be specified in addition if this will provide clearance over those obstacles at a specified lower OCA/H (see Part I, Section 4, Chapter 6, 6.2.3.1, “Climb gradient in the final phase”).

Table II-1-1-1. Minimum distance between localizer and glide path interceptions

<i>Intercept angle with localizer (degrees)</i>	<i>Cat A/B/H</i>	<i>Cat C/D/E</i>
0 — 15	2.8 km (1.5 NM)	2.8 km (1.5 NM)
16 — 30	3.7 km (2.0 NM)	3.7 km (2.0 NM)
31 — 60	3.7 km (2.0 NM)	4.6 km (2.5 NM)
61 — 90 or within a racetrack or reversal procedure	3.7 km (2.0 NM)	5.6 km (3.0 NM)

Table II-1-1-2. Height loss/altimeter margin

<i>Aircraft category (V_{at})</i>	<i>Margin using radio altimeter</i>		<i>Margin using pressure altimeter</i>	
	<i>Metres</i>	<i>Feet</i>	<i>Metres</i>	<i>Feet</i>
A – 169 km/h (90 kt)	13	42	40	130
B – 223 km/h (120 kt)	18	59	43	142
C – 260 km/h (140 kt)	22	71	46	150
D – 306 km/h (165 kt)	26	85	49	161
H – 167 km/h (90 kt)	8	25	35	115

Note 1.— *Cat H speed is the maximum final approach speed, not V_{at} .*

Note 2.— *For Category E aircraft refer directly to the equations given in 1.4.8.8.3.4.*

Table II-1-1-3. Objects which may be ignored in OCA/H calculations

	<i>Maximum height above threshold</i>	<i>Minimum lateral distance from runway centre line</i>
GP antenna	17 m (55 ft)	120 m
Aircraft taxiing	22 m (72 ft)	150 m
A/C in holding bay or in taxi holding position at a range between threshold and –250 m	22 m (72 ft)	120 m
A/C in holding bay or in taxi holding position at a range between threshold and –250 m (Cat I only)	15 m (50 ft)	75 m

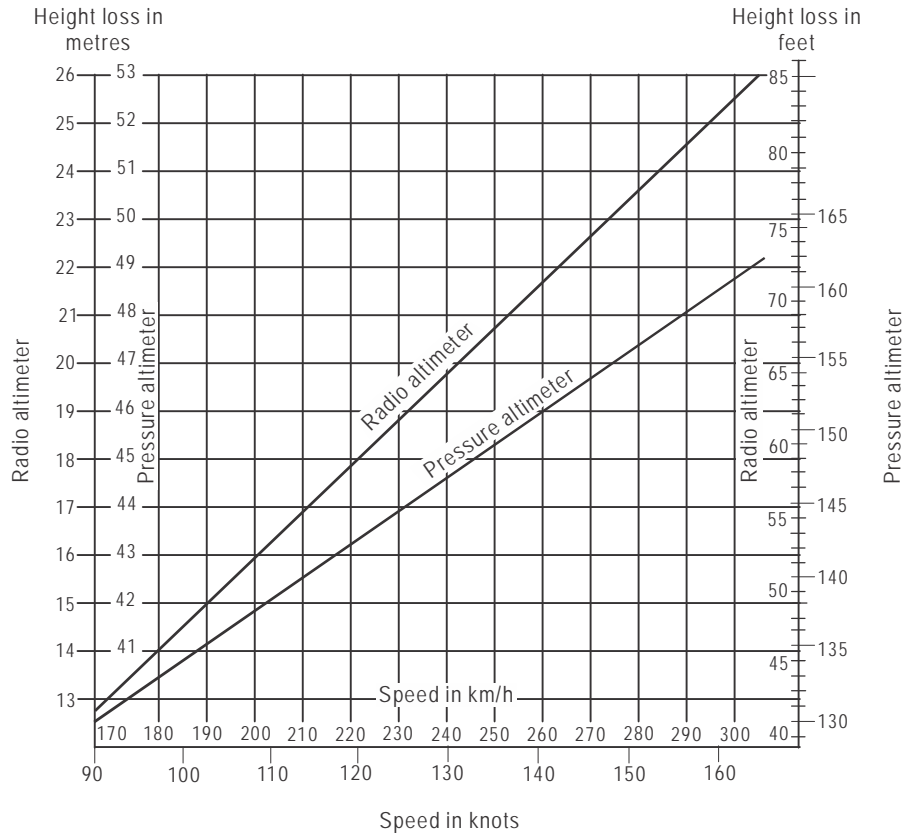

Table II-1-1-4. Height loss altimeter setting vs. speed

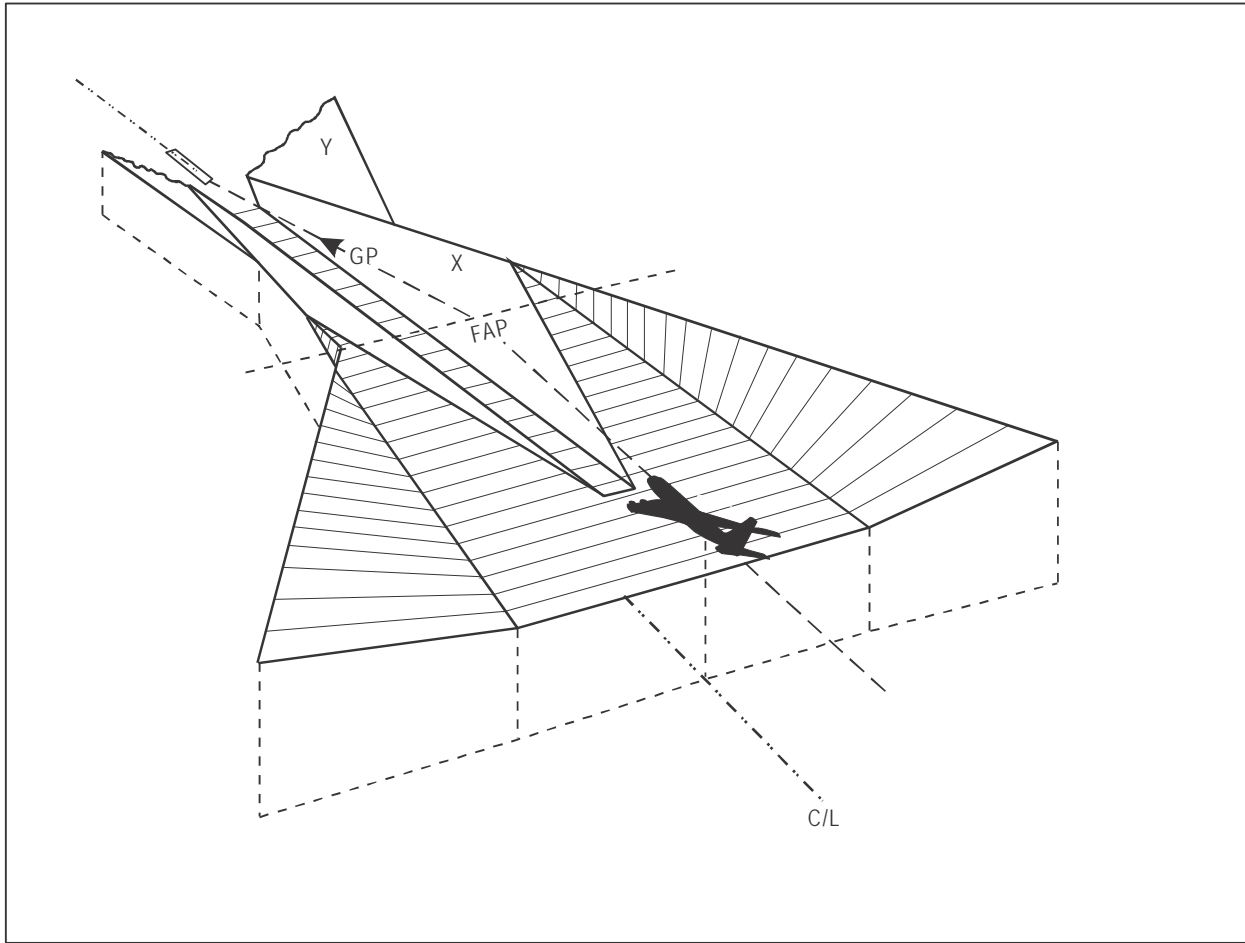

Figure II-1-1-1. Interface — final approach/preceding segment perspective view

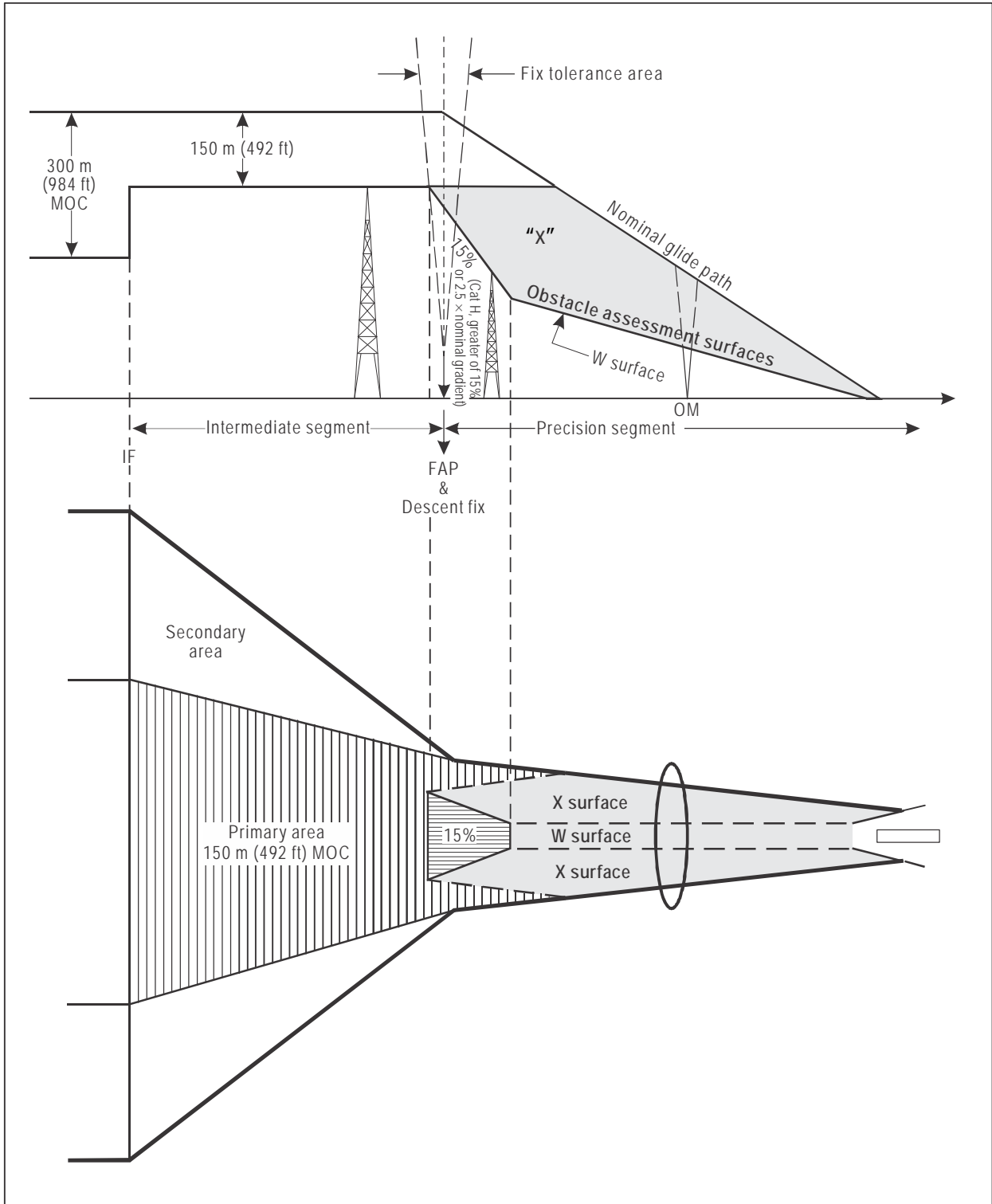

Figure II-1-1-2. Final approach fix defined by descent fix located at final approach point

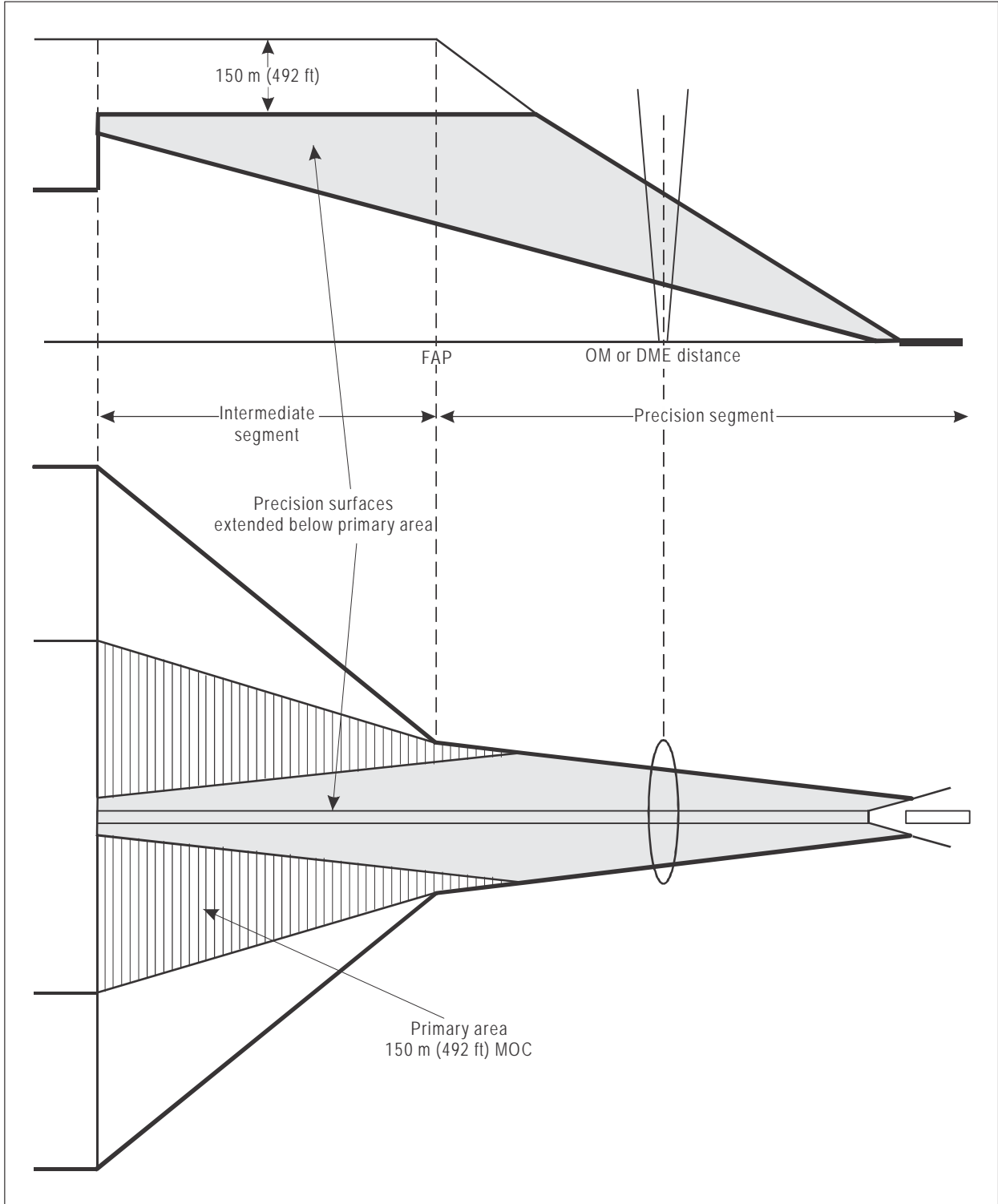

Figure II-1-1-3. Precision segment with no final approach fix

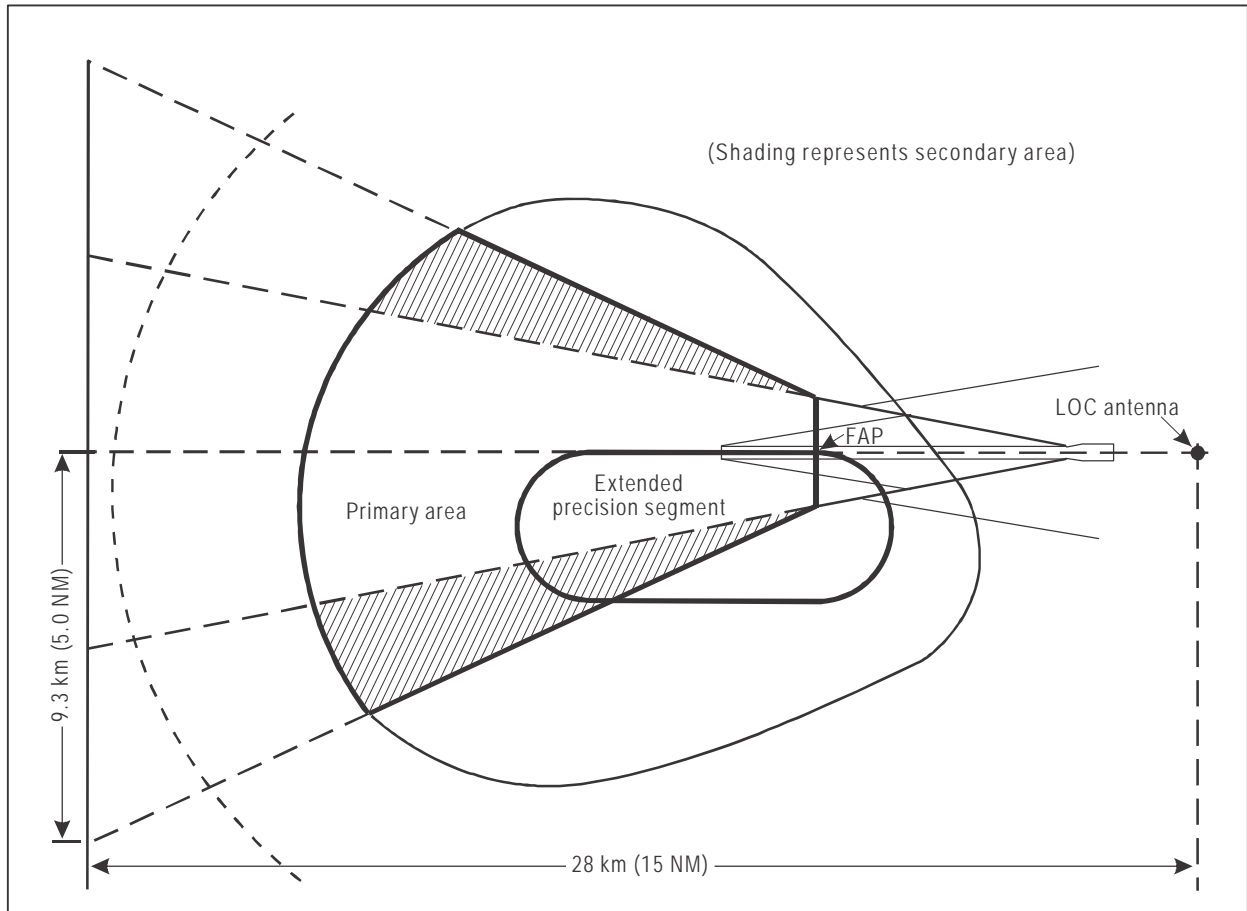

Figure II-1-1-4. Intermediate approach area. ILS approach using reversal or racetrack procedure

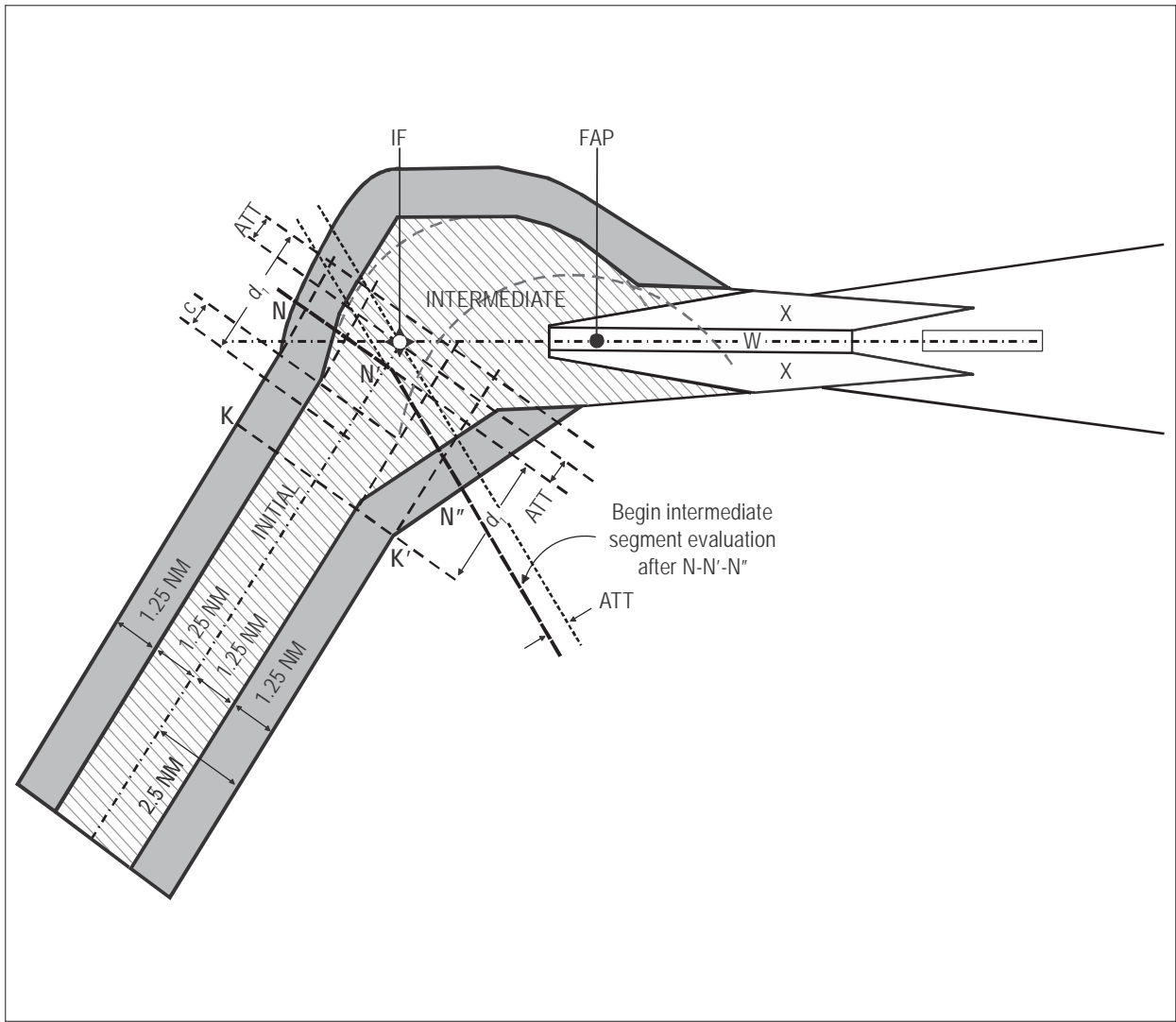

Figure II-1-1-5. Example: RNAV 1 or RNP 1 to ILS transition, 60° intercept

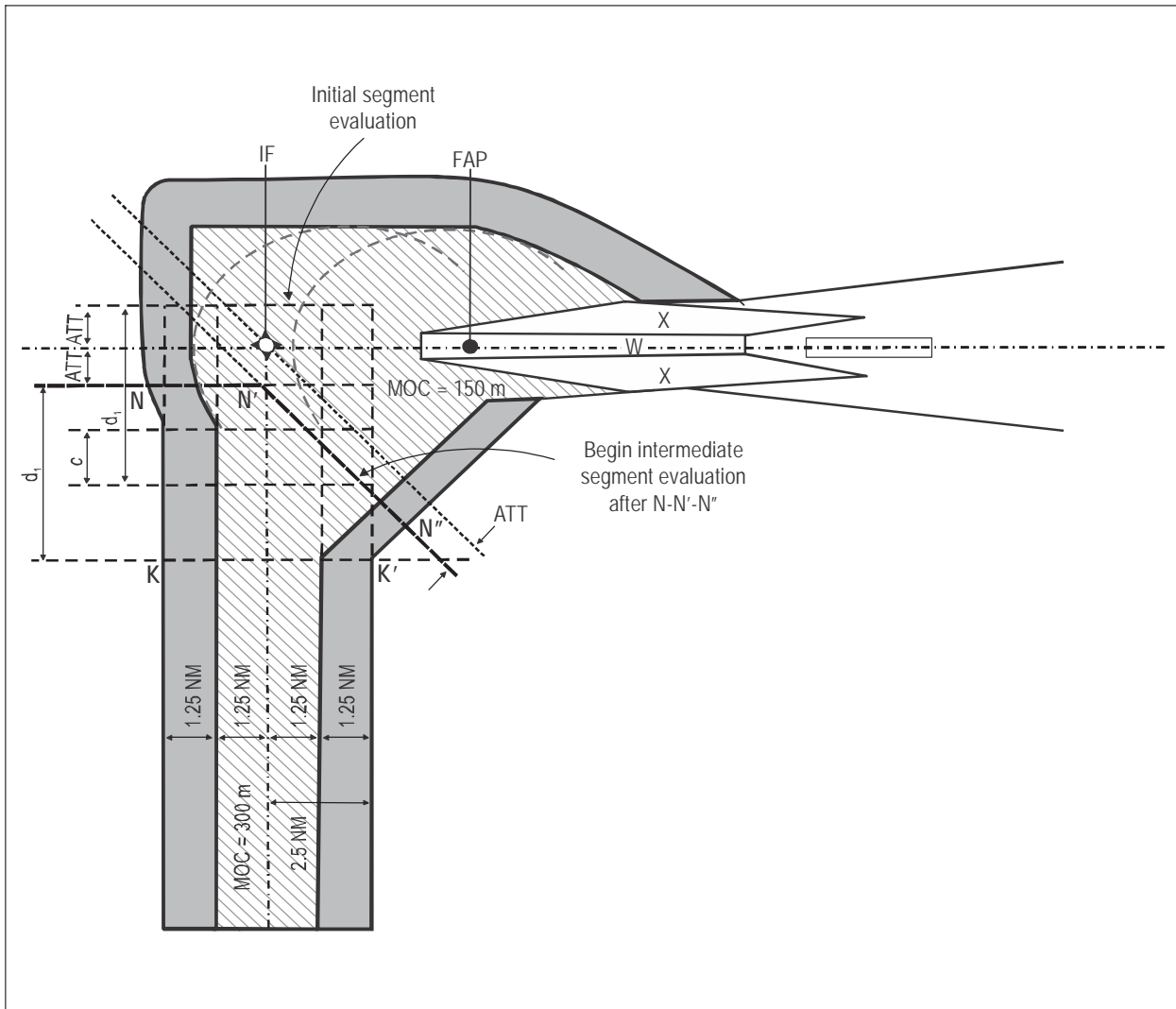

Figure II-1-1-6. Example: RNAV 1 or RNP 1 to ILS transition, 90° intercept (max)

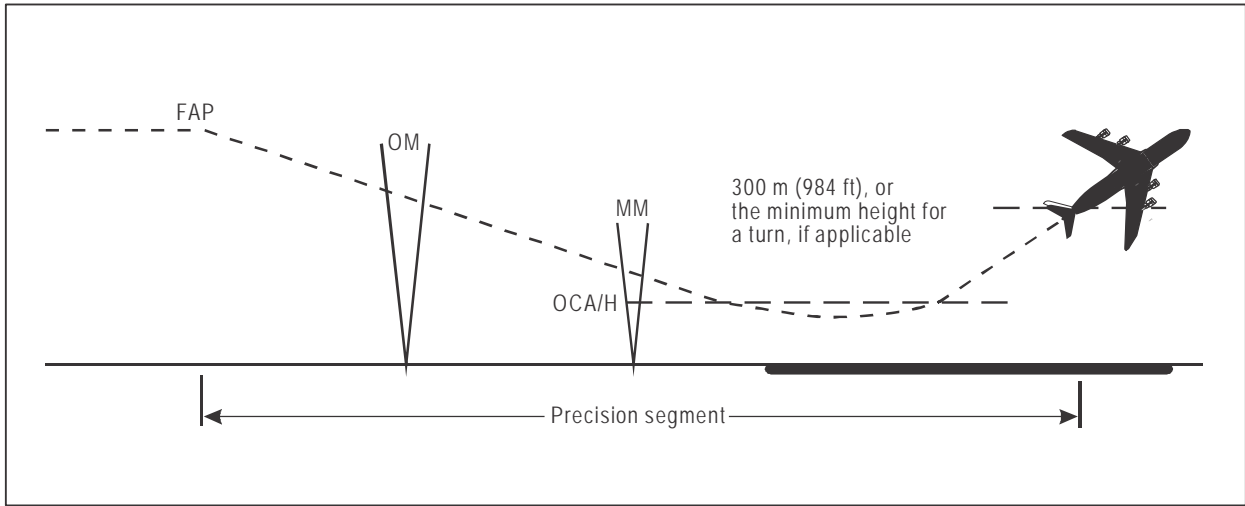

Figure II-1-1-7. Precision segment

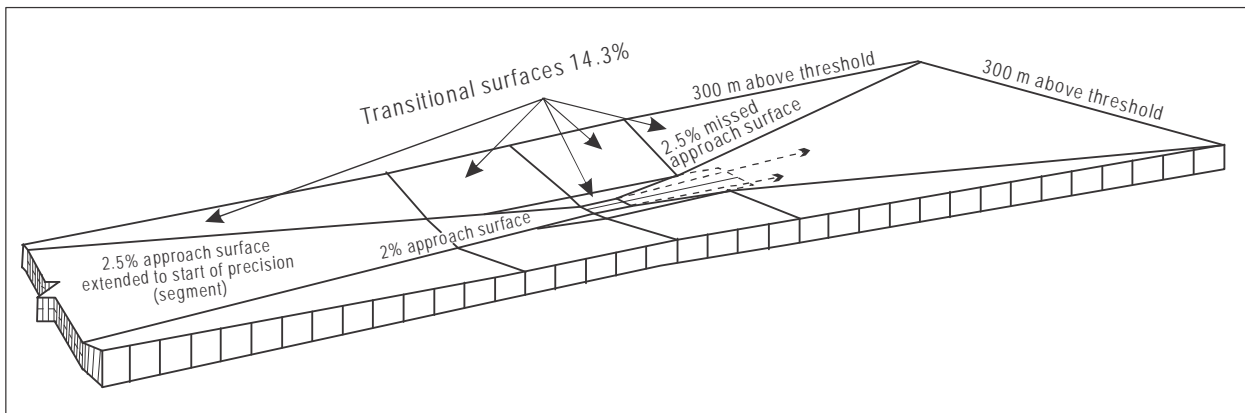

Figure II-1-1-8 a). Annex 14 inner approach, inner transitional and balked landing surfaces as applied for obstacle assessment for Cat II and III ILS operations

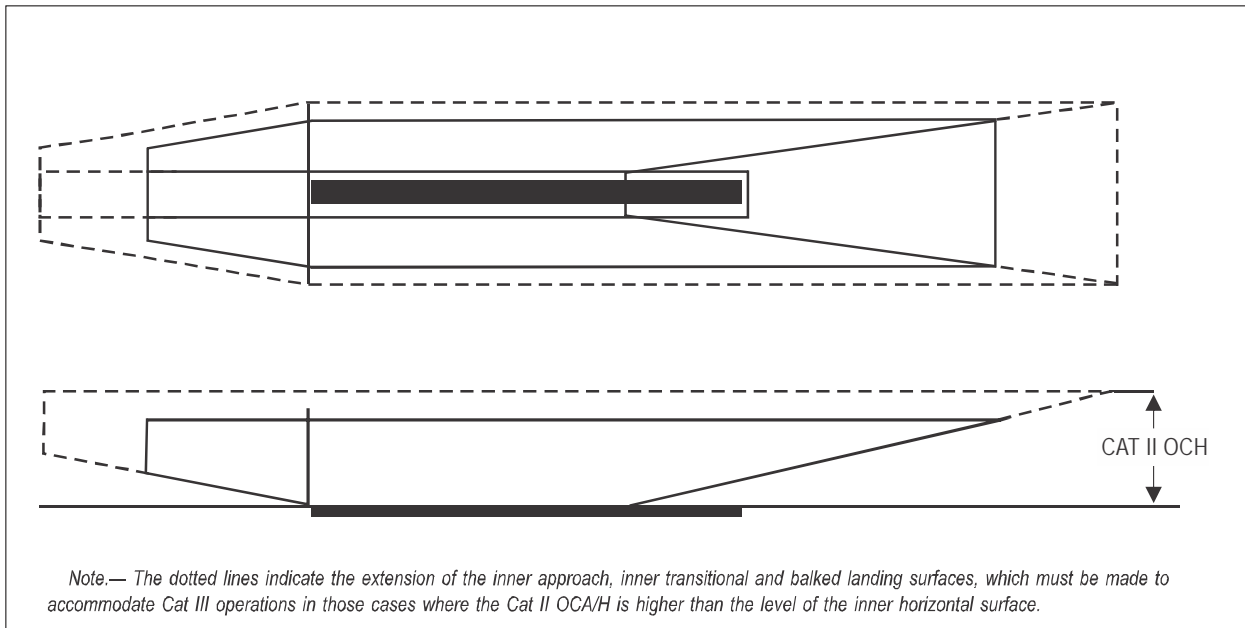

Figure II-1-1-8 b). Illustration of basic ILS surfaces as described in 1.4.7.2

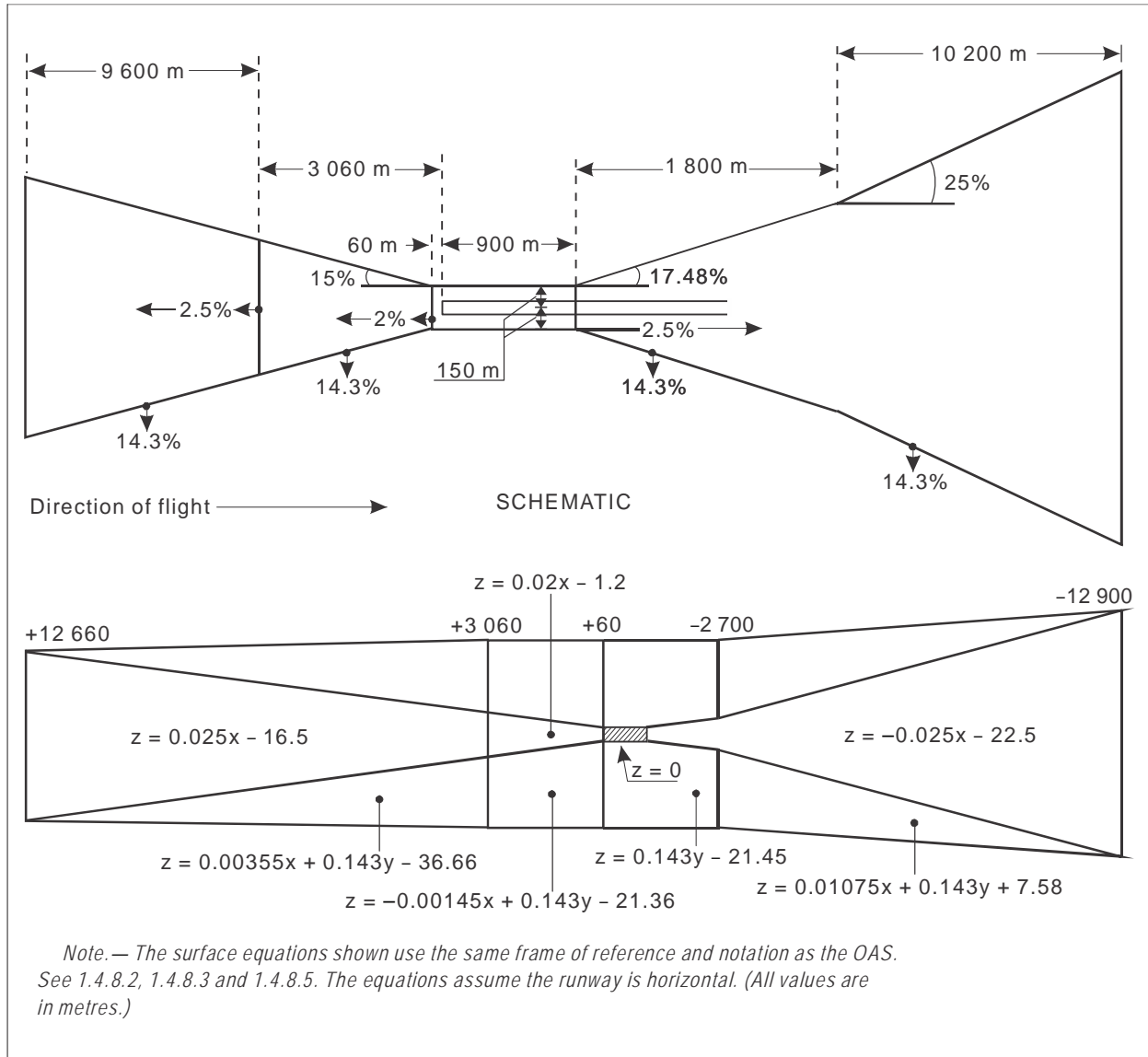

Figure II-1-1-9. Surface equations — basic ILS surfaces

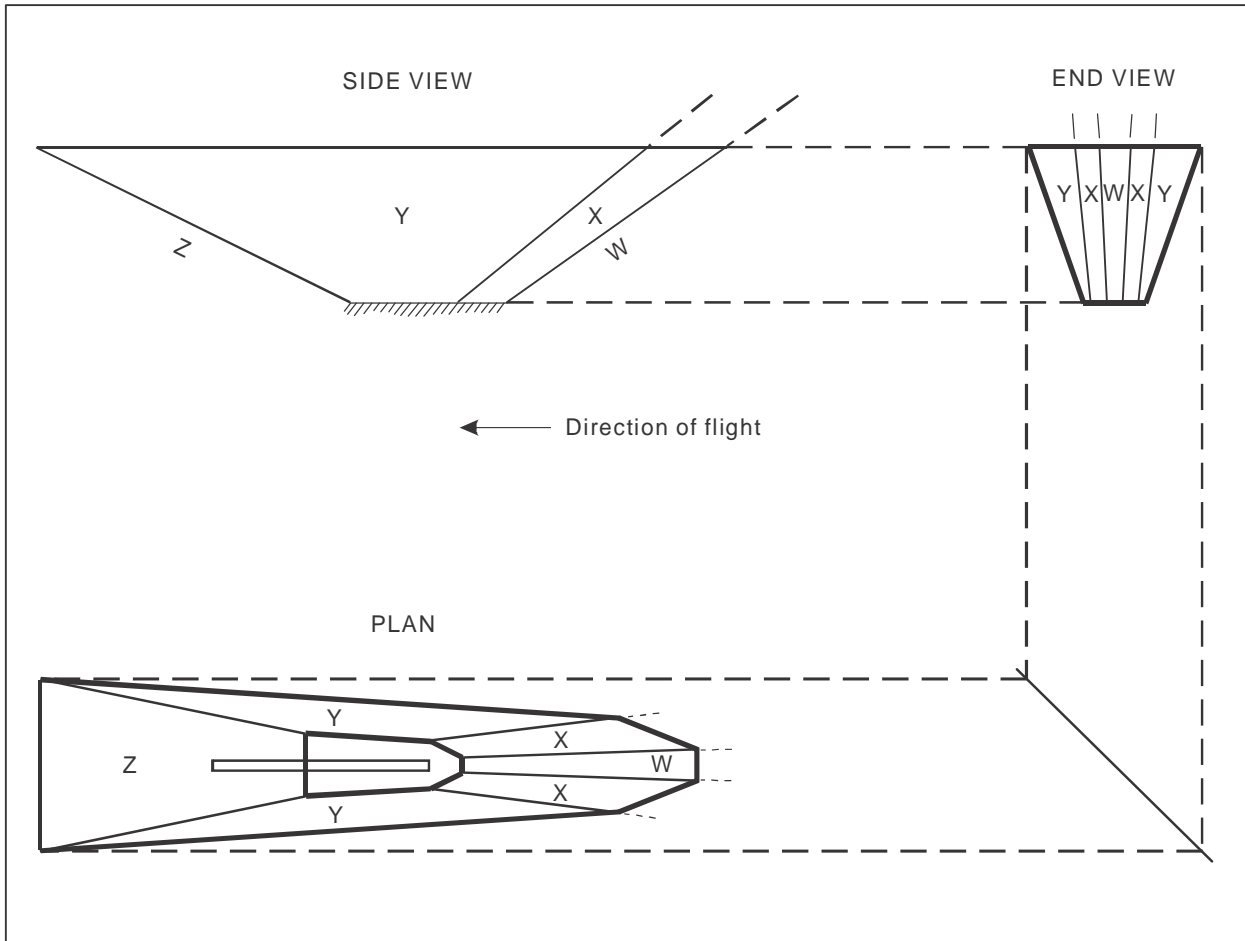

Figure II-1-1-10. Illustrations of ILS obstacle assessment surfaces

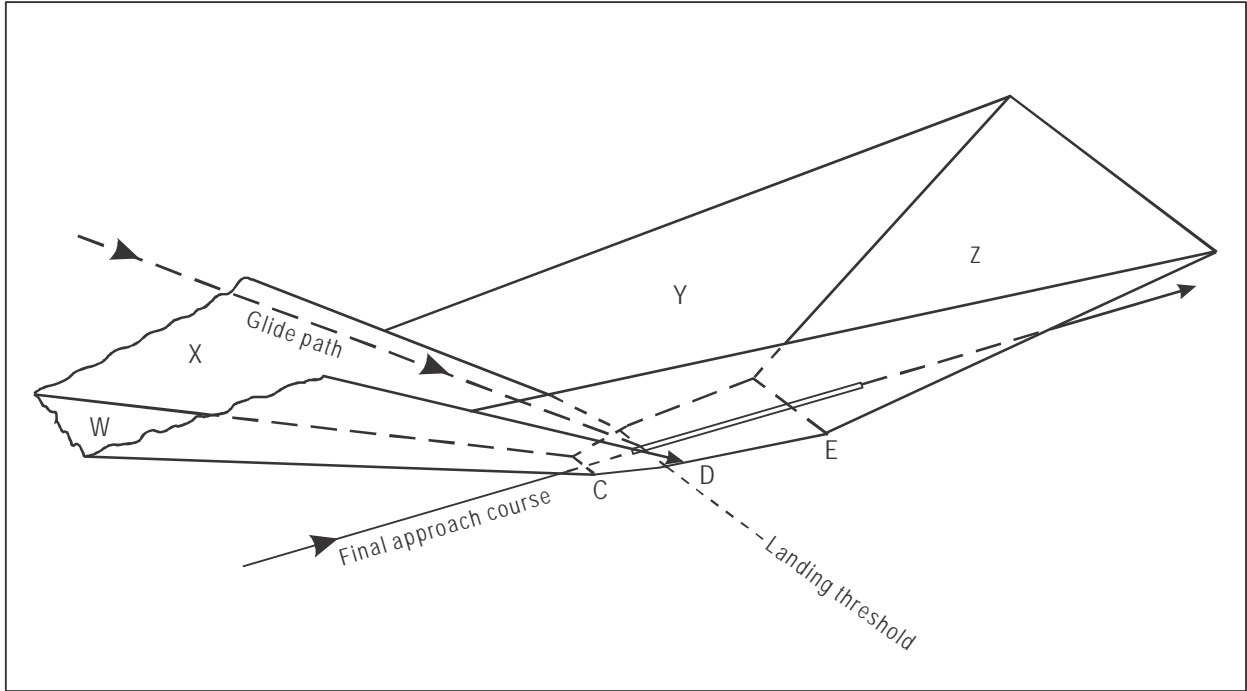

Figure II-1-1-11. Illustrations of ILS obstacle assessment surfaces — perspective view

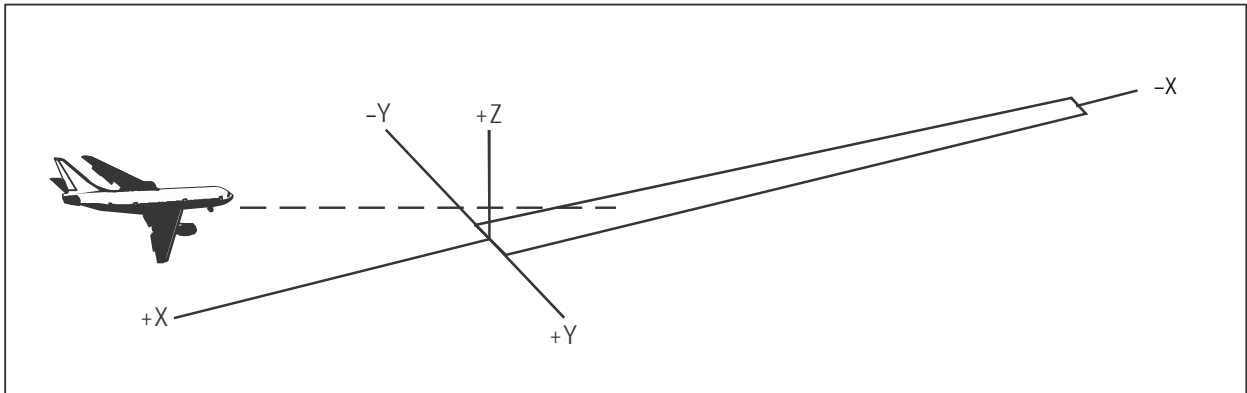

Figure II-1-1-12. System of coordinates

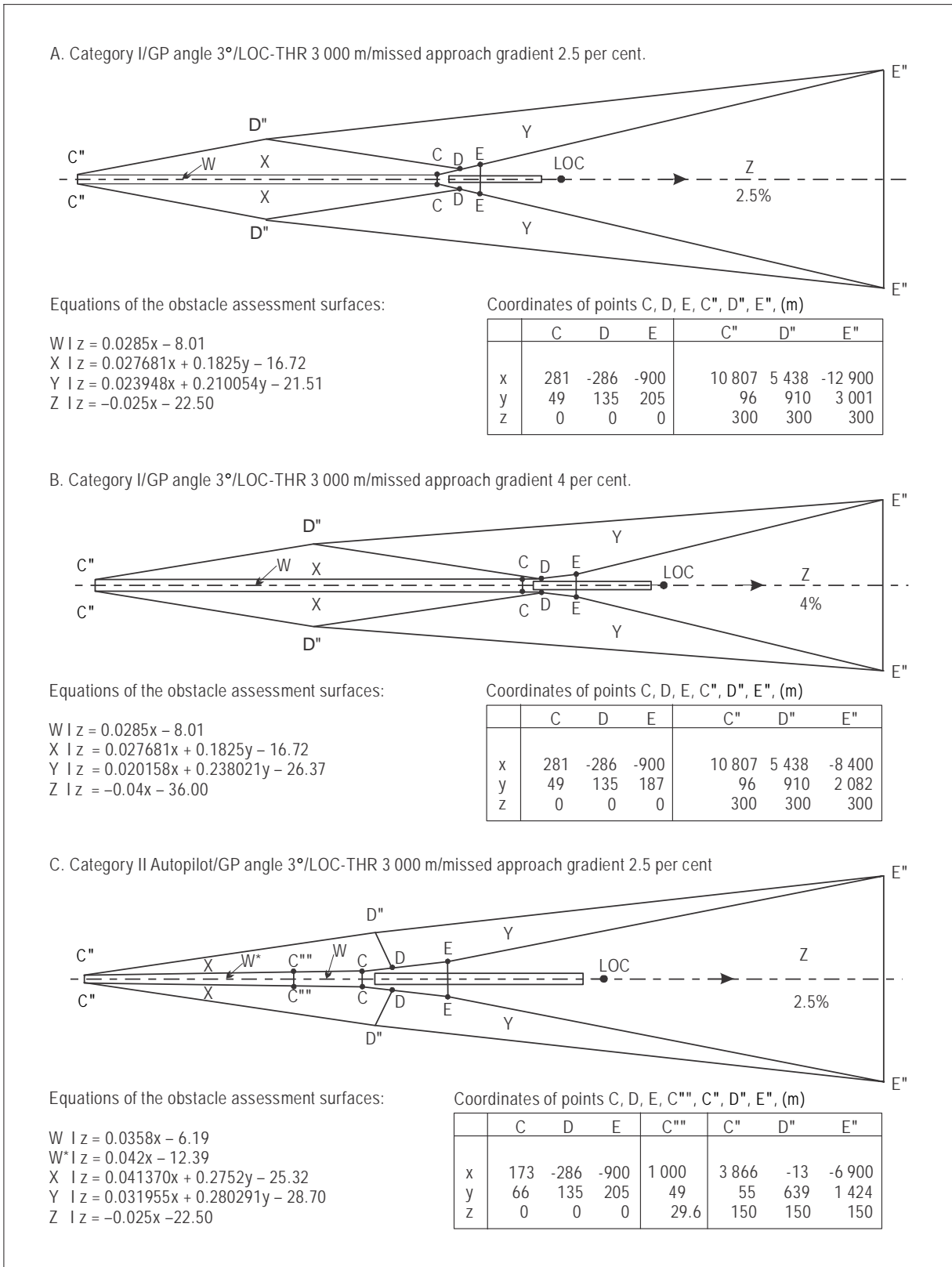

Figure II-1-13. Typical OAS contours for standard size aircraft

OAS

NAVIGATION AID DATA

Approach Category

Glide path (°) LOC THR Dist⁽¹⁾ m

RDH m Course width at THR m

AIRCRAFT DATA

M/App CG (%) CAT STD Wing Semi Span m GP Wheel / Antenna height m

OAS constants

	A	B	C		A	B	C
W	<input type="text" value="0.028500"/>	<input type="text" value="0.000000"/>	<input type="text" value="-8.01"/>	Y	<input type="text" value="0.023948"/>	<input type="text" value="0.210054"/>	<input type="text" value="-21.51"/>
W*				Z	<input type="text" value="-0.025000"/>	<input type="text" value="0.000000"/>	<input type="text" value="-22.50"/>
X	<input type="text" value="0.027681"/>	<input type="text" value="0.182500"/>	<input type="text" value="-16.72"/>				

OAS Template coordinates -m (metres)

THR Elevation			300 m Height		
	X	Y		X	Y
C	<input type="text" value="281"/>	<input type="text" value="49"/>	C"	<input type="text" value="10807"/>	<input type="text" value="96"/>
D	<input type="text" value="-286"/>	<input type="text" value="135"/>	C'''		
E	<input type="text" value="-900"/>	<input type="text" value="205"/>	D"	<input type="text" value="5438"/>	<input type="text" value="910"/>
			E"	<input type="text" value="-12900"/>	<input type="text" value="3001"/>

OAS height calculator

X m Y m Z m

(1) For MLS read: "Azimuth antenna to THR distance"; for GBAS read: "GARP-LTP distance".

Figure II-1-1-14. OAS output data generated by the PANS-OPS OAS software

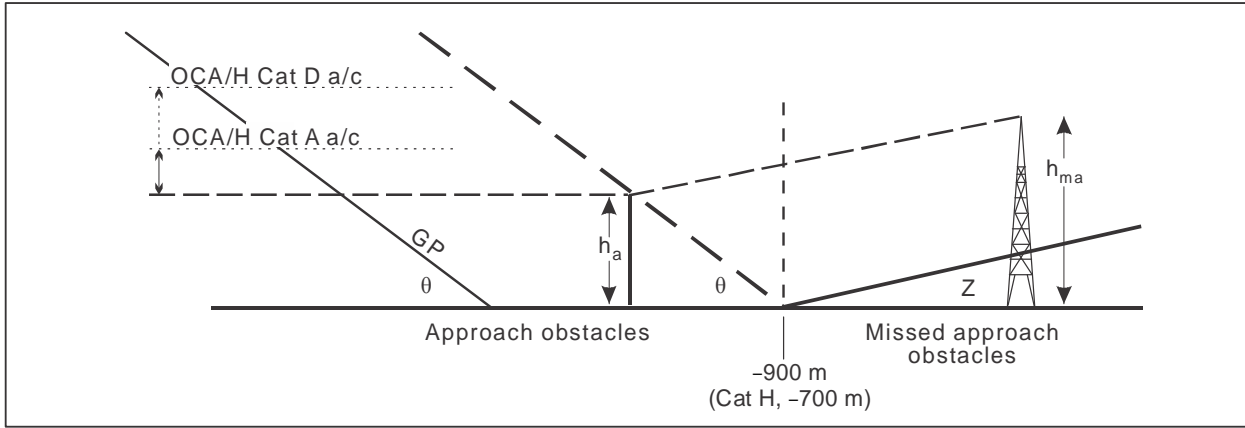

Figure II-1-1-15. Missed approach obstacle after range -900 m

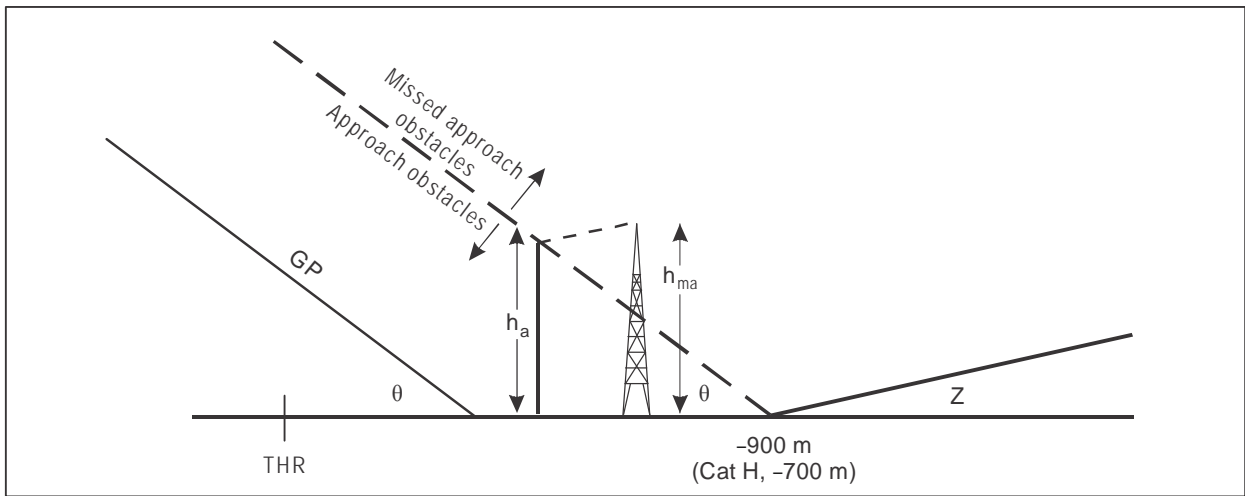

Figure II-1-1-16. Missed approach obstacle before range -900 m

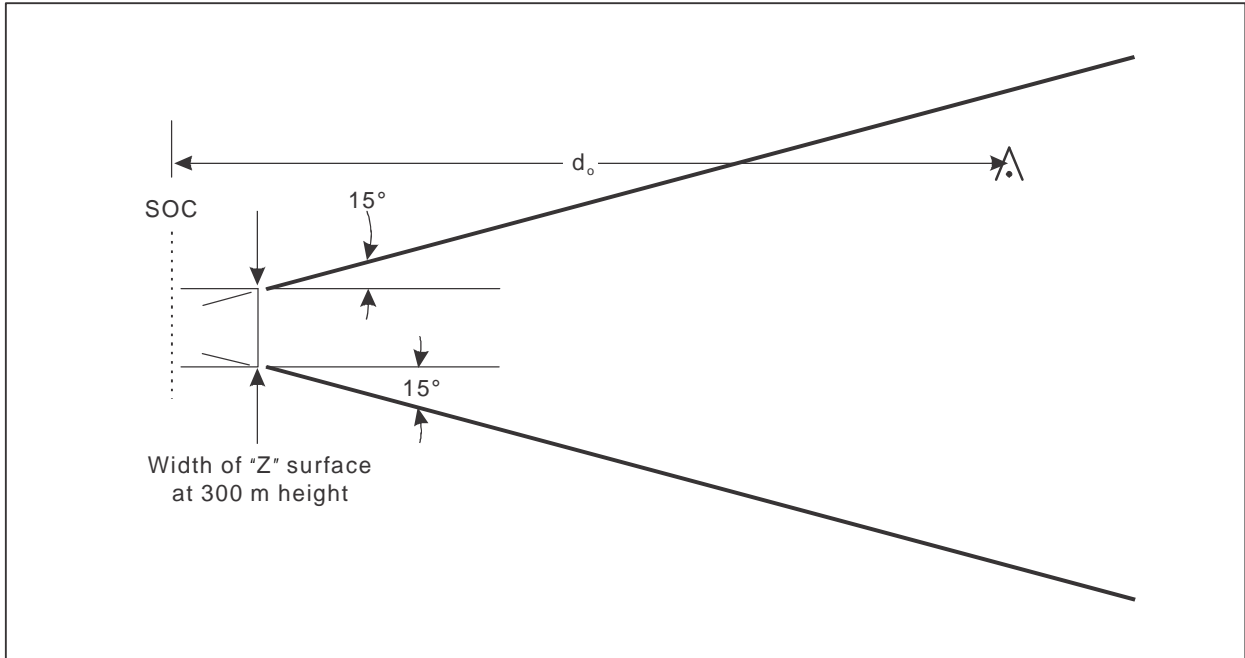

Figure II-1-1-17. Final segment of straight missed approach

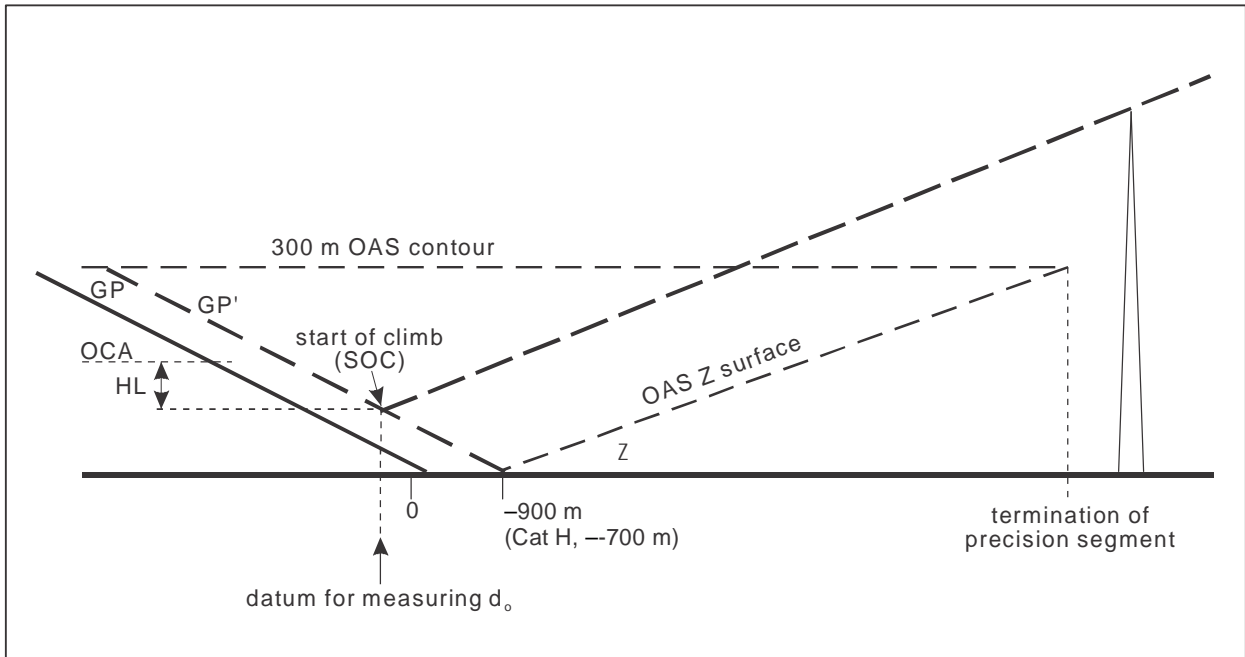

Figure II-1-1-18. Straight missed approach obstacle clearance

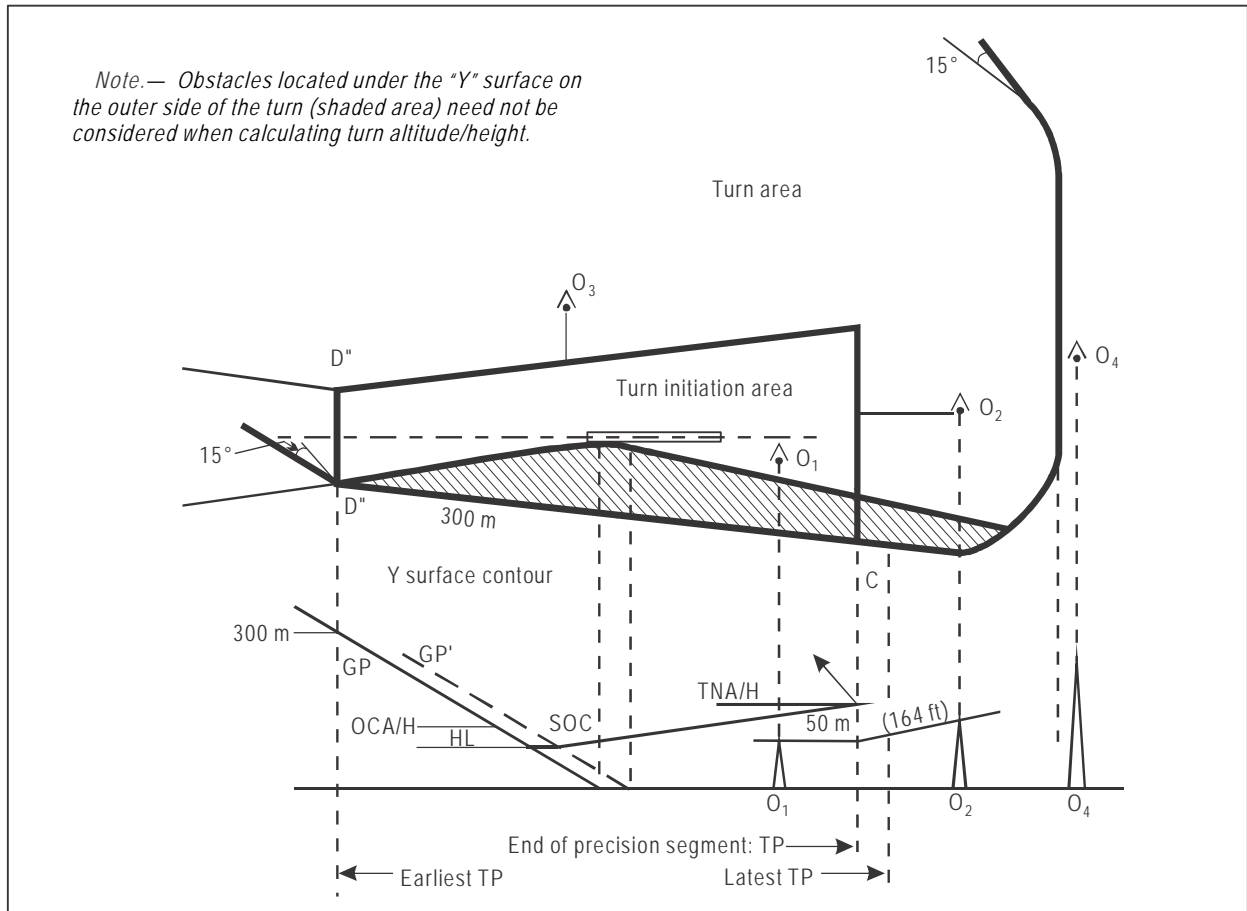

Figure II-1-1-19. Turn at a designated altitude

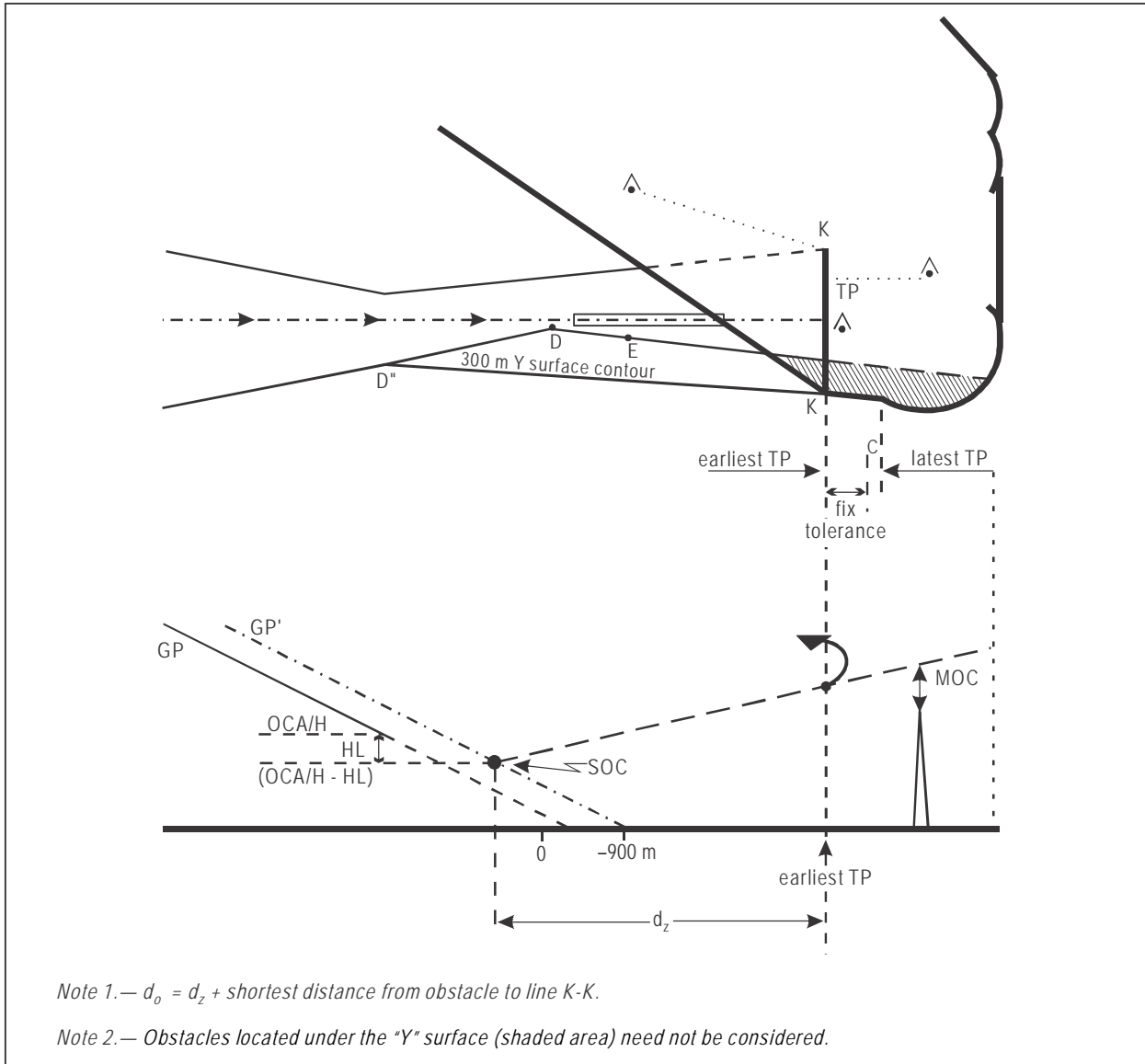

Figure II-1-1-20. Turn at designated TP (with TP fix)

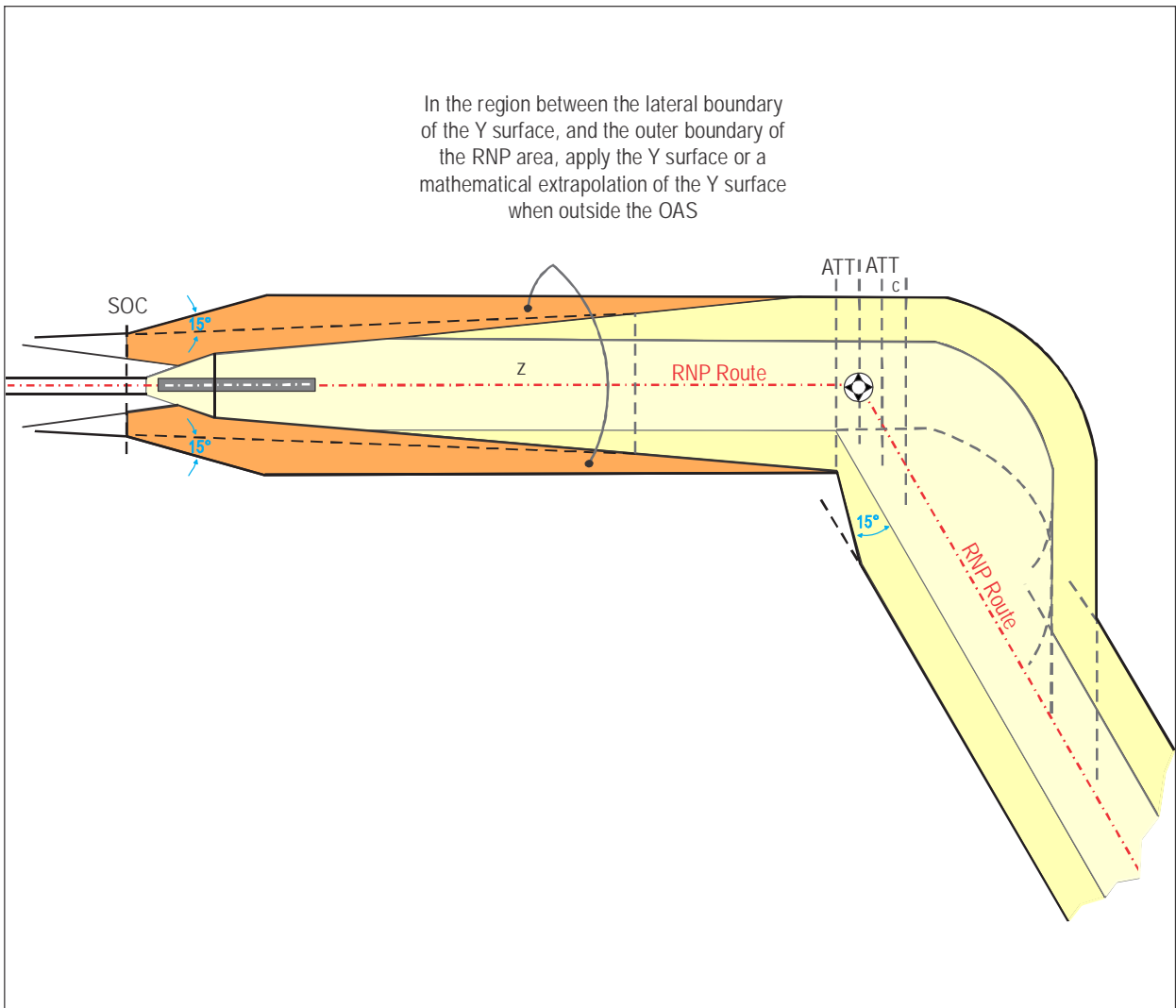

Figure II-1-1-21. Example: Transition to RNP 1, flyover turn after the precision segment

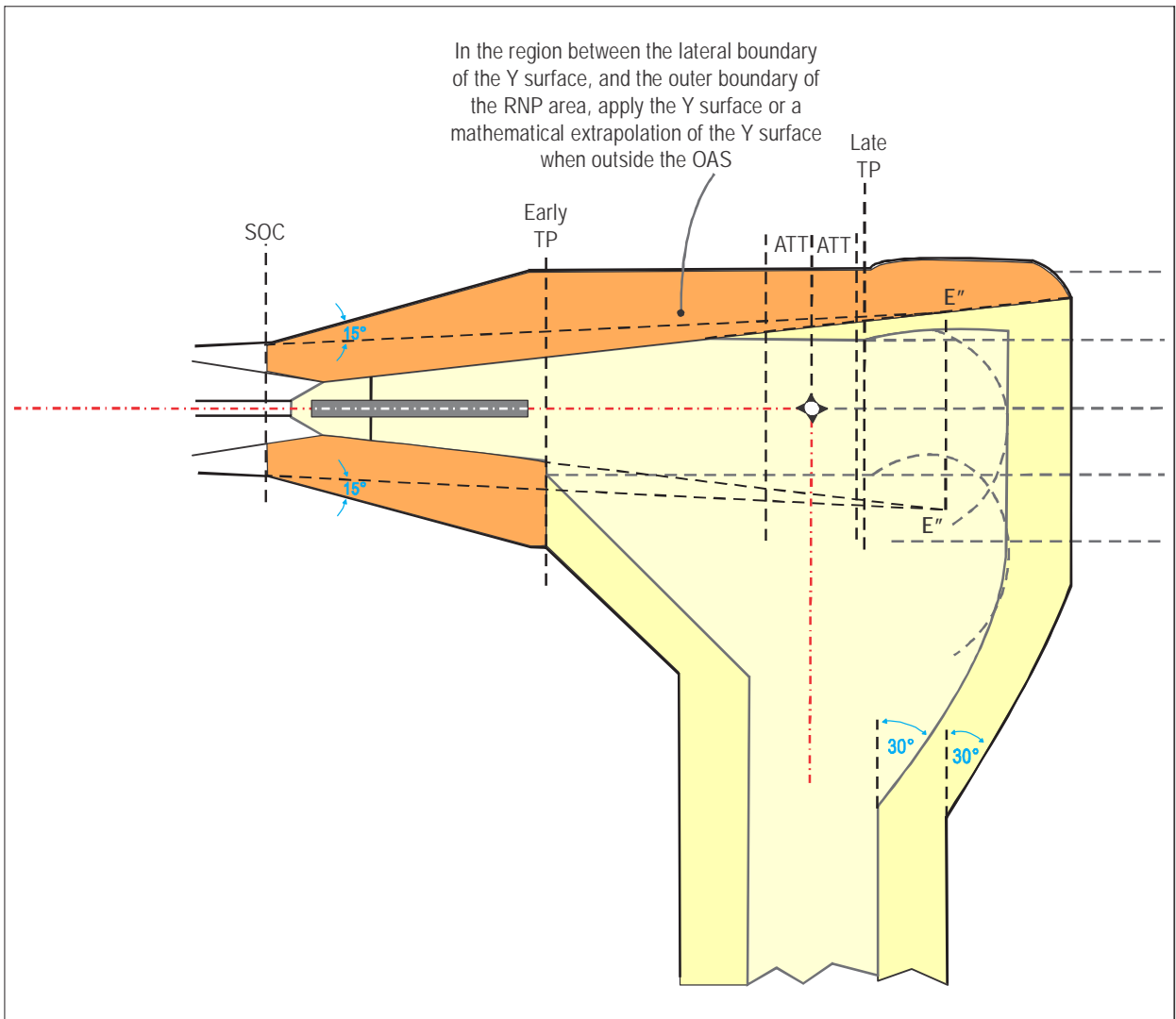

Figure II-1-1-22. Example: Transition to RNAV 1 or RNP 1, fly-by turn before the end of the precision segment

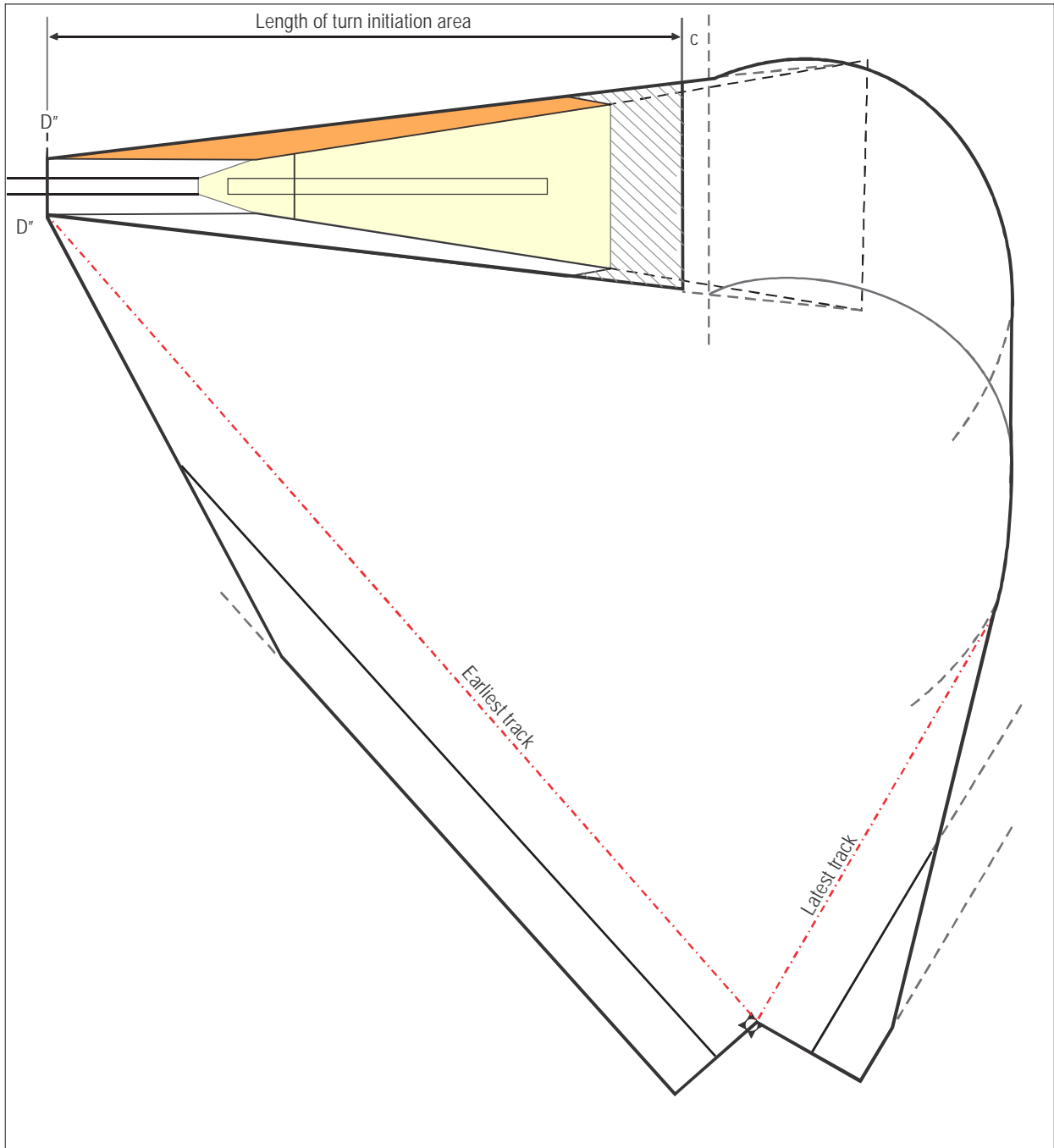

Figure II-1-1-23. Example: Turn at an altitude direct to an RNAV 1 or RNP 1 fix

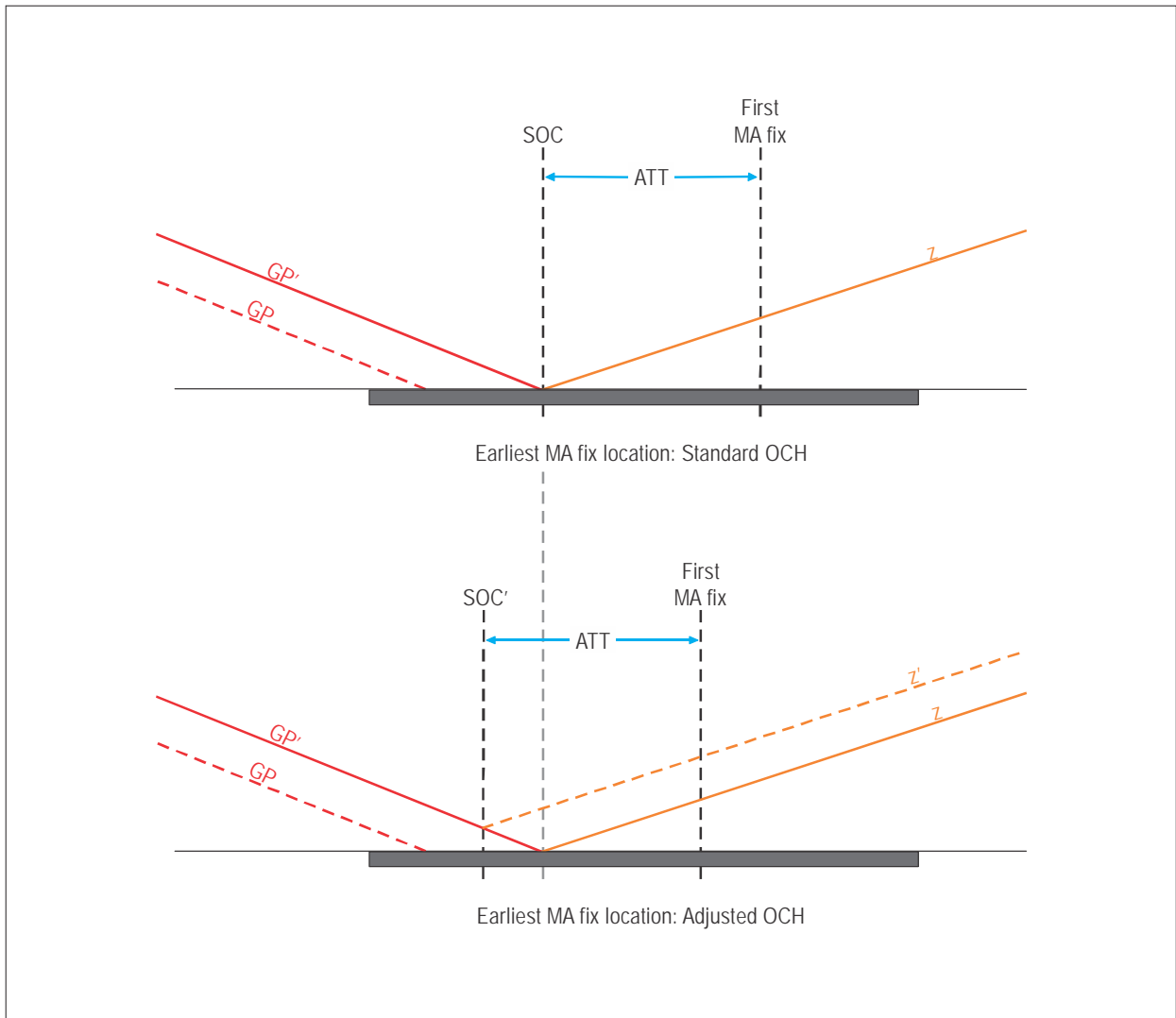

Figure II-1-1-24. Example: Earliest fix location for RNAV or RNP missed approach

Appendix A to Chapter 1

ILS: TURNING MISSED APPROACH ASSOCIATED WITH A PRECISION APPROACH

(see Chapter 1, 1.5.3, "Turning missed approach")

1. INTRODUCTION

1.1 This appendix contains some guidance material about the way to adjust the turn altitude or the TP location in the case of turning missed approach associated with a precision approach, and it gives some simple formulae to use when the OCA/H has to be increased.

1.2 This appendix also describes a method of treating a turn at an altitude from within the precision segment which reduces the penalty some obstacles cause when the more general techniques of Chapter 1, 1.5.3, "Turning missed approach" are used.

2. TURN ALTITUDE/TP LOCATION ADJUSTMENTS

2.1 Turn at an altitude

2.1.1 Assume that a turn at an altitude has been designed to avoid obstacle 01.

2.1.2 *Obstacle straight ahead in the turn area* (see Figure II-1-1-App A-1). If an obstacle in the turn area, located at 02, cannot be overflown with the adequate margin, the options to solve the problem are:

- a) lower the turn altitude in order to exclude 02 from the turn area. In this case obstacles in the turn initiation area (like 03) might become a problem. This means that it might not be possible to lower the turn altitude as much as needed (since turn altitude must be at least the elevation of obstacle 03 + MOC applicable to turns);
- b) restrict the final missed approach speed. Then the radius of turn will be reduced and the turn area might exclude 02. (Of course, if speed restriction is applied, the published speed shall be kept above the intermediate missed approach speed); and
- c) increase OCA/H. This will raise the turn altitude without moving the latest TP. New OCA/H can be found by using the method described in paragraph 3.

2.1.3 *Obstacle in the turn initiation area*. If an obstacle in the turn initiation area (like 03) is higher than the turn altitude less the margin applicable to turns, then the turn altitude has to be increased. The options are:

- a) increase the turn altitude by moving the latest TP further from the SOC. This is acceptable to the extent that 01 still remains outside the turn area;

- b) if this does not appear to be possible, the final missed approach speed might be restricted, to reduce the radius of turn and keep 01 outside the turn area; and
- c) increase OCA/H without moving the latest TP. New OCA/H can be found by using the formula in paragraph 3.

2.1.4 *Obstacle in the turn area abeam the straight ahead missed approach track.* If an obstacle in the turn area, like 04, cannot be overflown with the appropriate margin, the options a) or b) presented in 2.1.3, “Obstacle in the turn initiation area” above, will be used.

2.2 Turn at a designated TP

2.2.1 *Obstacle straight ahead in the turn area.* If an obstacle straight ahead in the turn area cannot be overflown with the appropriate margin (like 02 in Figure II-1-1-App A-2), the options are:

- a) move the TP closer to the SOC in order to exclude 02 from the turn area. The difficulty in this case is that it might then be difficult to get the vertical margin applicable to turns at the earliest TP (which will occur at a lower point of the nominal flight path);
- b) if this cannot be solved, the final missed approach speed might be restricted in order to decrease the radius of turn and exclude 02 from the area; and
- c) increase OCA/H by using the method shown in paragraph 3.

2.2.2 *Obstacle abeam the straight ahead missed approach track (and before the earliest TP range).* If an obstacle like 04 (see Figure II-1-1-App A-2) cannot be overflown with the appropriate margin, the options to solve the problem are:

- a) move the TP further from the SOC. This will increase the nominal altitude over the obstacle and could even exclude 04 from the turn area. Of course this is acceptable to the extent obstacle 01 (see Figure II-1-1-App A-2) can be kept outside the area;
- b) if this is not possible, then the final missed approach speed might be restricted; and
- c) increase OCA/H by using the method shown in paragraph 3.

3. CALCULATION OF OCA/H

3.1 Calculation of OCH from obstacle data (h_o , d_o)

Whenever there are obstacles in the turn area it is possible to find the OCH compatible with these obstacles by using the formula:

$$\text{OCH} = \frac{(h_o + \text{MOC}) \cot Z - d + 900}{\cot Z + \cot \theta} + \text{HL}$$

where: h_o is the height (in meters) of the obstacle above threshold

θ is the glide path angle

MOC is the margin applicable to turns (in metres) and

$$d \text{ (in metres)} = \text{distance (threshold to TP)} + d_o$$

In the case of a turn at an altitude:

d_o is the shortest distance from obstacle to the turn initiation area boundary and

$$d = \text{distance (threshold to earliest TP)} + d_o$$

In the case of turn at a designated TP:

d_o is the shortest distance from the obstacle to the earliest TP (line K-K).

3.2 Calculation of OCH from an amount of altitude missing above an obstacle

This method is applicable whenever it has been established that one obstacle is a problem. This means that the nominal altitude above the obstacle will not be adequate for an airplane climbing at the SOC from the previously calculated OCH. If we express the difference in altitude as dif (alt), the necessary increase of OCH (dif (OCH)) will be obtained by the formula:

$$\text{dif (OCH)} = \frac{\text{dif (alt)} \cot Z}{\cot Z + \cot \theta}$$

This method may also be applied for turns at altitude, when an obstacle in the turn initiation area is higher than (turn altitude – MOC). Then the necessary increase of OCH (see 2.1.3, “Obstacle in the turn initiation area”, item b)) will be obtained by the formula above where:

$$\text{dif (alt)} = \text{obstacle elevation} + \text{MOC} - \text{previous turn altitude.}$$

4. TECHNIQUE FOR REDUCTION OF THE TURN AREA FOR A TURN AT AN ALTITUDE FROM INSIDE THE PRECISION SEGMENT

4.1 Turn initiation area

The turn initiation area can be more precisely defined by plotting an area which consists of two parts. The first part is the area enclosed by the turn altitude OAS contour truncated at the turn point as described in Chapter 1, 1.5.3.2.1. The second part of the area is bounded by:

- a) the 300 m OAS contour truncated by the line joining the D” points; and
- b) two lines D_{TL} defined as follows:

$$D_T = (\text{HL} - \text{RDH}) \cot \theta + 900 \text{ m SI units}$$

where D_T is the distance from a missed approach point on GP to the corresponding SOC on GP'.

The distance D_T is then plotted from each D'' point in the direction of E'' to points Y and V. Lines D_{TL} are then constructed through points Y and V from the 300 m OAS contour to the turn altitude OAS contour so that they are parallel to the lines DD'' . The area enclosed by the two parts of the construction is the turn initiation area (see Figure II-1-1-App A-3).

4.2 Turn area

The turn area outer boundary may now be constructed from the turn initiation area described above using the principles and techniques detailed in Part I, Section 2, Chapter 3, “Turn area construction” and applying them to points D'' , V, W and X. However, when the outer boundary (line B — see Figure II-1-1-App A-4) becomes parallel to line D_{TL} and for turns through all greater angles, a turn spiral from point Y must also be considered.

4.3 Obstacle clearance for turns less than 75°

4.3.1 *Turn areas for turns less than 75°.* The turn area is divided into four areas for application of obstacle clearance. Area 1 is contained within the turn height OAS contour truncated by the turn point line. The other areas are defined by the turn area boundaries — and lines 1 and 2 in Figure II-1-1-App A-5 which are drawn parallel to the early turn boundary and from the most penalistic point of the turn height OAS contour and the turn point line respectively. The areas are numbered from 1 to 4 as shown in Figure II-1-1-App A-5.

4.3.2 *Area 1.* In area 1, the obstacle elevation/height shall be less than:

$$\text{Turn altitude/height} - \text{MOC}$$

$$\text{MOC} = 50 \text{ m (164 ft) for turns over } 15^\circ \text{ and}$$

$$\text{MOC} = 30 \text{ m (98 ft) for turns of } 15^\circ \text{ or less.}$$

4.3.3 *Area 2.* In area 2, the obstacle elevation/height shall be less than:

$$\text{Turn altitude/height} + d_o \tan Z - \text{MOC}$$

where: d_o = shortest distance from the obstacle to the turn point line (see Figure II-1-1-App A-6)

Z = angle of missed approach surface

$$\text{MOC} = 50 \text{ m (164 ft) for turns over } 15^\circ \text{ and } 30 \text{ m (98 ft) for turns of } 15^\circ \text{ or less.}$$

4.3.4 *Area 3.* In area 3, the obstacle elevation/height shall be less than:

$$\text{Turn altitude/height} + d_o \tan Z - \text{MOC}$$

where: d_o = distance from the obstacle to the turn altitude OAS contour measured along a line parallel to the early turn boundary (see Figure II-1-1-App A-6)

Z = angle of the missed approach surface

$$\text{MOC} = 50 \text{ m (164 ft) for turns over } 15^\circ \text{ and } 30 \text{ m (98 ft) for turns of } 15^\circ \text{ or less.}$$

4.3.5 *Area 4.* In area 4, the obstacle height shall be less than:

$$A_w X_M + C_w + d_o \tan Z - MOC$$

where: A_w = W surface OAS coefficient A

X_M = OAS X coordinate for point M

C_w = W surface OAS coefficient C

d_o = distance from the obstacle to the W OAS surface measured along a line parallel to the early turn boundary (see Figure II-1-1-App A-6)

Z = angle of the missed approach surface

MOC = 50 m (164 ft) for turns over 15° and 30 m (98 ft) for turns of 15° or less.

4.3.6 *Obstacles not considered.* Obstacles in the shaded area of Figure II-1-1-App A-6 do not require consideration as missed approach obstacles because the precision segment has considered their missed approach significance and because the missed approach turns the aircraft away from them. The inner boundaries of this area are the turn point line extended, the turn altitude OAS contour and the W OAS surface.

4.4 Obstacle clearance for turns greater than 75°

4.4.1 *Turn areas for turns greater than 75°.* The turn area is divided into two areas for application of obstacle clearance. The first area is that contained within the turn altitude OAS contour truncated by the turn point line as described in 4.3.1, “Turn areas for turns less than 75°” above. In this area the obstacle elevation/height shall be less than:

$$\text{Turn altitude/height} - 50 \text{ m}$$

In the remainder of the area, the obstacle elevation/height shall be less than:

$$\text{Turn altitude/height} + d_o \gamma - 50 \text{ m}$$

where: d_o = shortest distance from the obstacle to the turn altitude OAS contour or the turn point line (see Figure II-1-1-App A-7)

γ = either the climb gradient of the missed approach surface or the OAS W surface coefficient A, whichever is the lesser.

4.4.2 *Obstacles not considered.* Obstacles beneath the portion of the outer Y surface which is bounded by:

- a) the 300 m contour;
- b) the turn altitude OAS contour;
- c) the turn point line extended; and
- d) the DD” line;

need not be considered as missed approach obstacles (see the shaded portion of Figure II-1-1-App A-7).

4.5 OCH greater than 140 m

The constructions described in 4.3.1, “Turn areas for turns less than 75°” and 4.4.1, “Turn areas for turns greater than 75°” above will not be possible when the OCH is greater than approximately 140 m. Figures II-1-1-App A-6 and II-1-1-App A-7 are then modified as shown in Figures II-1-1-App A-8 and II-1-1-App A-9 respectively.

5. PROMULGATION

If, for a turn at altitude, the final missed approach speed is restricted in order to reduce the radius of turn and exclude an obstacle, then the published speed shall be kept above the intermediate missed approach speed.

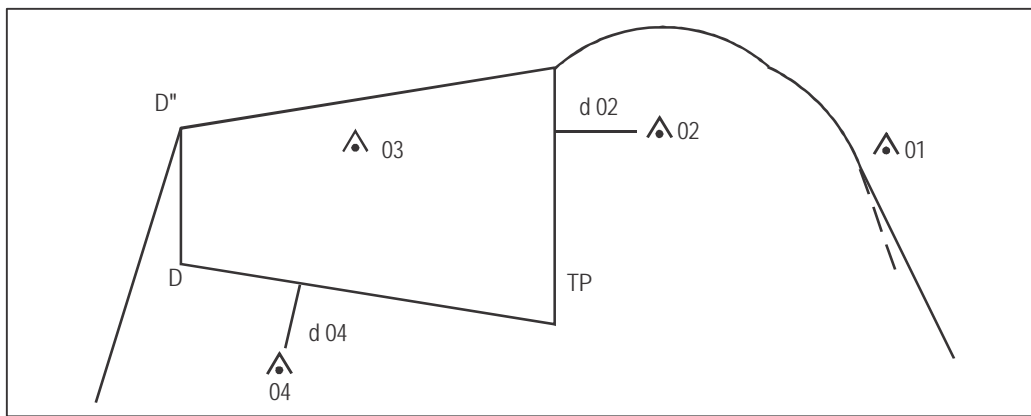

Figure II-1-1-App A-1. Turn at an altitude

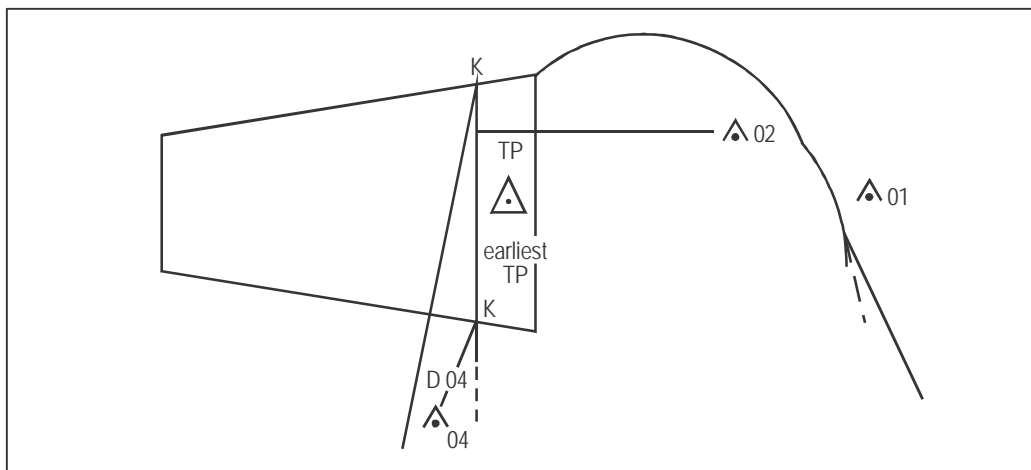

Figure II-1-1-App A-2. Turn at a designated turning point

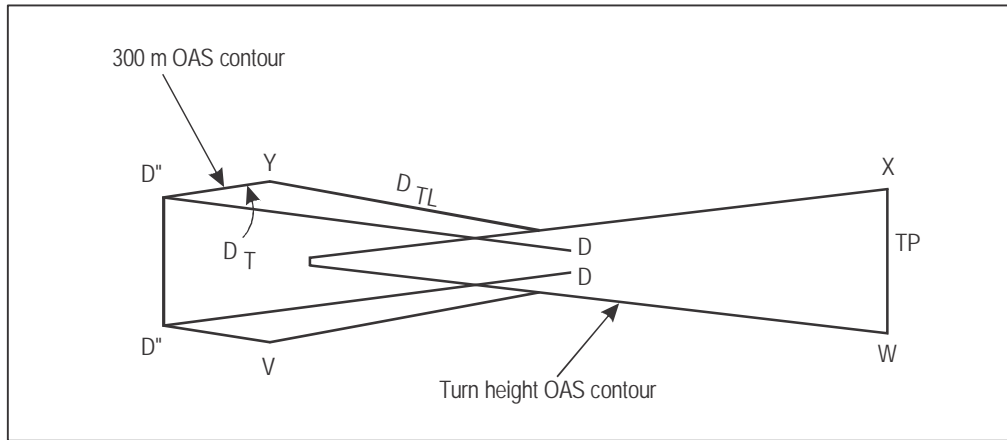

Figure II-1-1-App A-3. Turn initiation area (turn height 90 m)

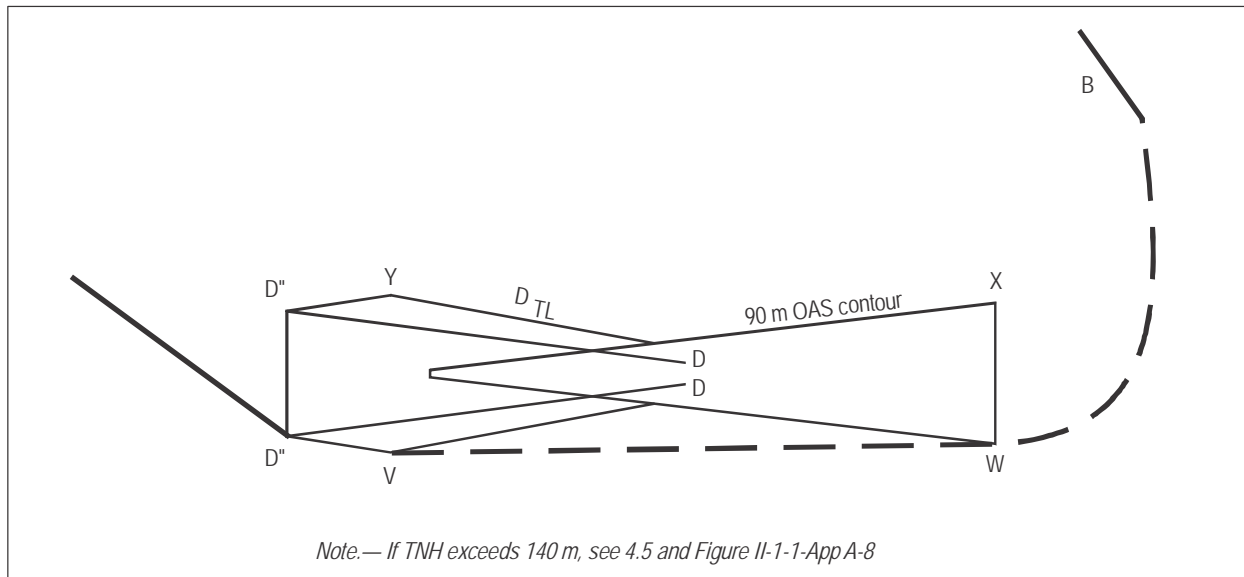

Figure II-1-1-App A-4. Turn area (TNH = 90 m)

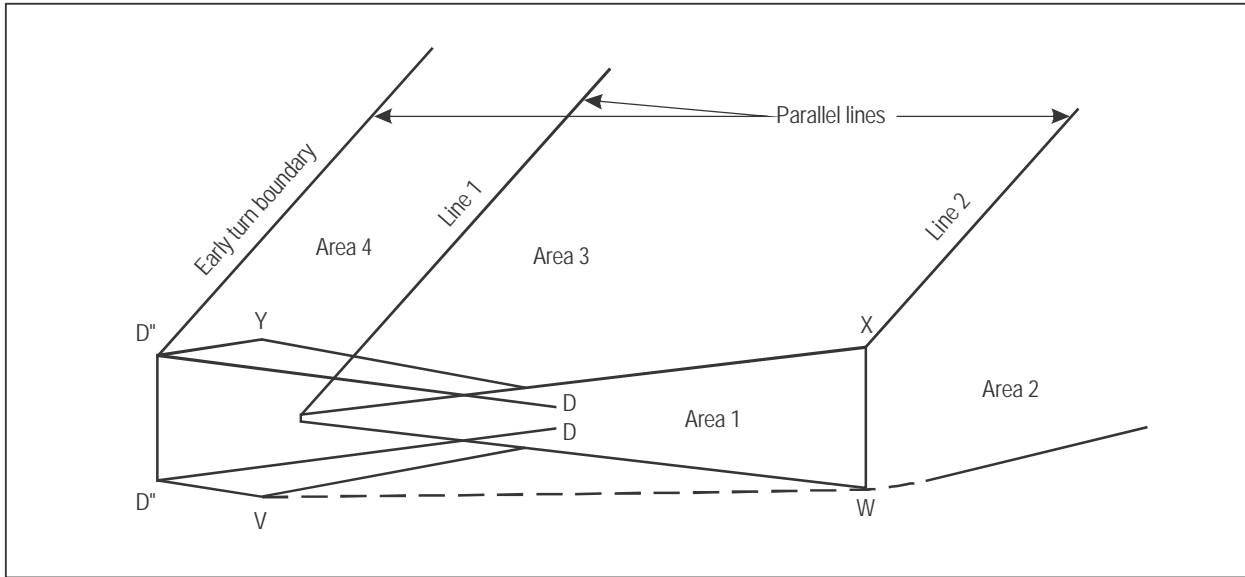

Figure II-1-1-App A-5. Areas for the application of obstacle clearance (TNH = 90 m)

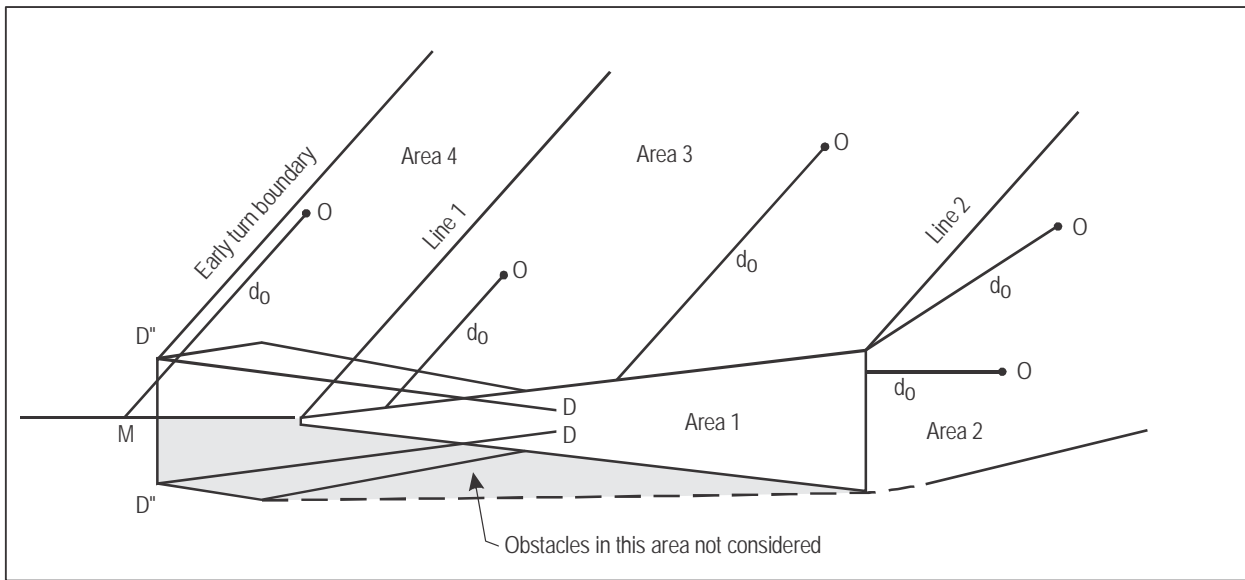

Figure II-1-1-App A-6. Measurement of distances d_0 to obstacles (turn less than 75°)

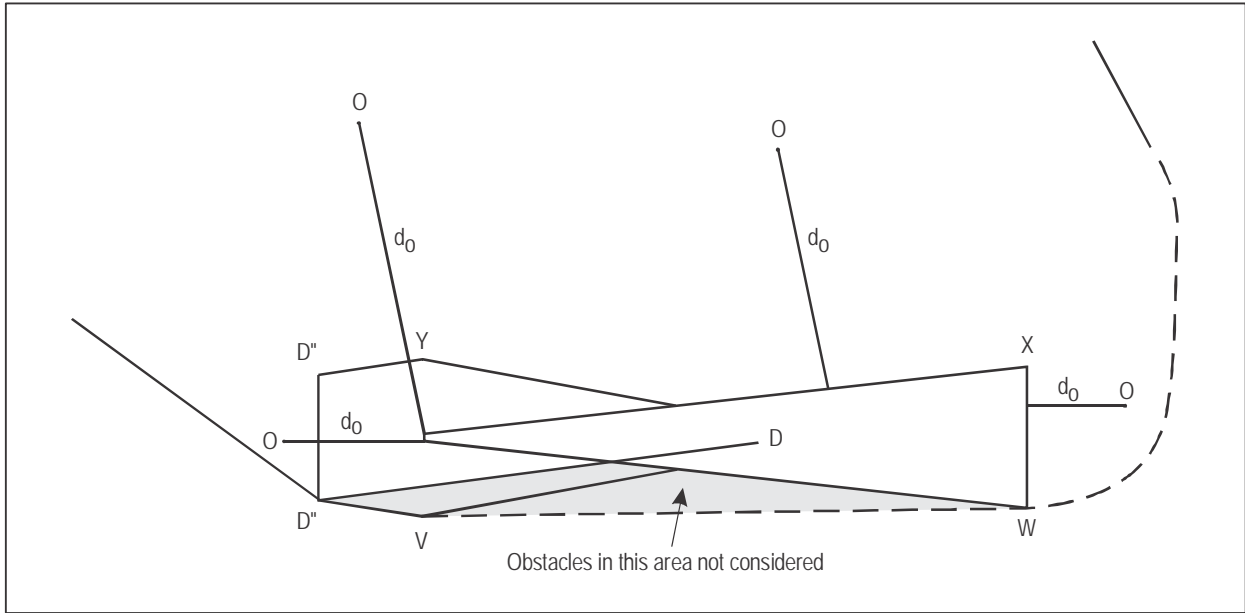

Figure II-1-1-App A-7. Measurement of distances d_o to obstacles (turn more than 75°)

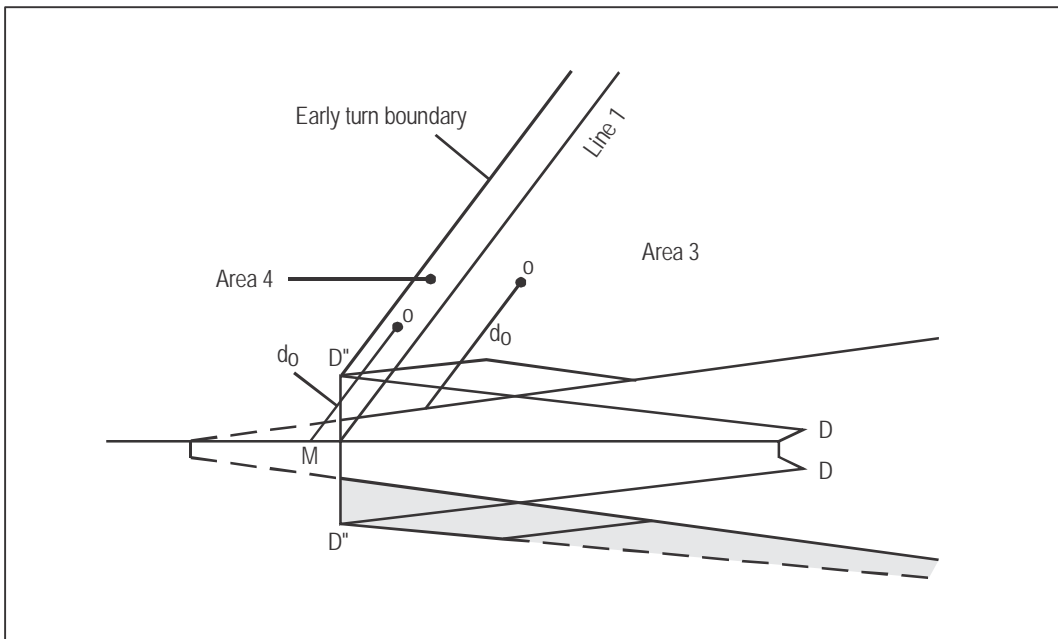

Figure II-1-1-App A-8. Case when TNH is above 140 m approximately (turn less than 75°)

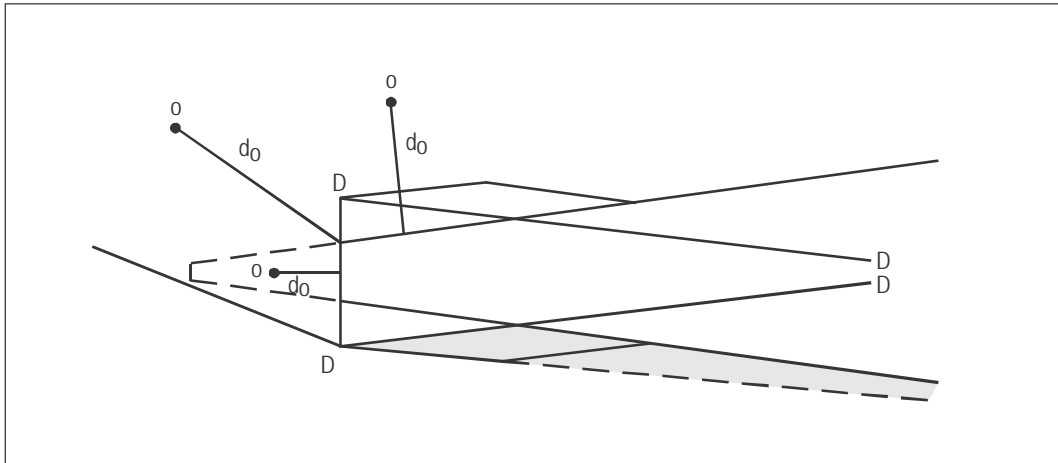

Figure II-1-1-App A-9. Case when TNH is above 140 m approximately (turn more than 75°)

Appendix B to Chapter 1

ILS OR MLS: STEEP GLIDE PATH ANGLE APPROACHES

1. GENERAL

Glide path angles above 3.5° should be used in approach procedure design only for obstacle clearance purposes and must not be used as a means to introduce noise abatement procedures. Such procedures are non-standard and require a special approval.

2. PROCEDURE DESIGN

2.1 Obstacle clearance criteria

The following obstacle clearance criteria should be adjusted for specific glide path angle:

- a) the W surface of the OAS;
- b) origin of the Z surface of the OAS; and
- c) height loss/altimeter margin (see paragraph 3).

2.2 Determination of the OAS coefficients

W surface: Coefficient A_w is determined by the formula

$$A_w = 0.0239 + 0.0092 (\theta - 2.5)$$

where θ is the glide path angle in degrees.

Coefficient $C_w = -6.45$

X and Y surfaces: The X and Y surface coefficients for 3.5° glide path at the appropriate localizer/threshold distance are used for all glide path angles greater than 3.5°.

Z surface: The coefficient C_z for the Z surface is determined by the formula

$$C_z = -A_z X_{z0}$$

where A_z is the A coefficient for the selected missed approach gradient; and X_{z0} is the new co-ordinate of the Z surface origin:

$$X_{z0} = -900 - 50 (\theta - 3.5^\circ)/0.1^\circ$$

2.3 Determination of the height of equivalent approach obstacle

Use the formula:

$$h_a = [h_{ma} \cot Z + (x - X_{zo})]/(\cot Z + \cot \theta)$$

- where:
- h_a = height of equivalent approach obstacle
 - h_{ma} = height of missed approach obstacle
 - θ = glide path angle
 - Z = angle of missed approach surface
 - X_{zo} = new co-ordinate of Z surface origin
 - x = range of obstacle relative to threshold (negative after threshold).

Note.— In using criteria specified in the text and drawings of paragraphs 1.5 and Chapter 3, 3.5, “Missed approach segment” use the newly calculated co-ordinate of “Z” surface origin (X_{zo}) instead of the value of -900 m.

2.4 Re-survey of obstacles

As the configuration of the OAS is changed, a re-survey of obstacles may be required.

2.5 Promulgation

A special note shall be included on the instrument approach chart stating that appropriate aircraft and crew qualifications are required to use such a procedure (see Annex 4, 11.10.8.6).

3. HEIGHT LOSS MARGIN AND OTHER CONSIDERATIONS

3.1 Height loss margins for glide paths greater than 3.5° or less than 3.5°

The height loss margin can be obtained by extrapolation from the formulas in 1.4.8.8.3.1 and Chapter 3, 3.4.8.8.3.1, both entitled “Height loss (HL)/altimeter margins”. However, this extrapolation may not be valid for glide paths greater than 3.5° or less than 3.5° when the nominal rate of descent (V_{at} for the aircraft type \times the sine of the glide path angle) exceeds 5 m/sec (1 000 ft/min), unless certification on flight trials has verified the effects of:

- a) minimum drag configuration;
- b) effect of wind shear;
- c) control laws;
- d) handling characteristics;
- e) minimum power for anti-icing;

- f) GPWS modification;
- g) use of flight director/autopilot;
- h) engine spin-up time; and
- i) V_{at} increase for handling considerations.

3.2 Additional operational considerations for height loss margin

In addition, the height loss margin may be inadequate unless operational consideration is given to configuration, engine-out operation, maximum tail wind — minimum head wind limits, GPWS, weather minima, visual aids and crew qualifications, etc.

Appendix C to Chapter 1

DETERMINING ILS GLIDE PATH DESCENT/MLS ELEVATION HEIGHTS AND DISTANCES

1. ILS/MLS glide path heights (H) and horizontal distances (D) from the threshold are calculated by solving a right-angle triangle:

SI units

$$H = h + 1\,000 D \tan \theta \text{ and } D = 0.001(H - h) \cot \theta$$

where: H = height in metres

h = reference datum height in metres

D = distance from the threshold in kilometres

θ = glide path angle in degrees

Non-SI units

$$H = h + 6\,076 D \tan \theta \text{ and } D = 0.0001646(H - h) \cot \theta$$

where: H = height in feet

h = reference datum height in feet

D = distance from the threshold in nautical miles

θ = glide path angle in degrees

2. The influence of the curvature of the earth's surface should be considered in order to check that the heights and distances to the threshold determined in this manner meet the Annex 10 and PANS-OPS requirements. To perform such a check, Tables II-1-1-App C-1 and II-1-1-App C-2 may be used. For intermediate distances, heights and glide path angles, the linear interpolation method is used.

For reference datum heights (h) other than 15 m (49 ft):

a) the values obtained from Table II-1-1-App C-1 should be corrected by adding ΔH where:

SI units: $\Delta H = h - 15$ (Table II-1-1-App C-1a))

and

Non-SI units: $\Delta H = h - 49$ (Table II-1-1-App C-1b))

b) the values obtained from Table II-1-1-App C-2 should be corrected by adding ΔD where:

SI units: $\Delta D = 0.00092(15 - h) \cot \theta$ (Table II-1-1-App C-2a))

and

Non-SI units: $\Delta D = 0.0001514(49 - h) \cot \theta$ (Table II-1-1-App C-2b))

The following formulae may be used for intermediate distances, heights and glide path angles as well as for values which are greater than the maximum values indicated in Tables II-1-1-App C-1 and II-1-1-App C-2:

SI units: $H = h + 1\,000 D \tan \theta + 0.0785 D^2$

and

Non-SI units: $H = h + 6\,076 D \tan \theta + 0.8833 D^2$

3. Heights are rounded up to the nearest multiple of 5 m (10 ft), and distances are rounded to the nearest tenth of a kilometre (nautical mile).

Note 1.— When heights are rounded up to the nearest multiple of 5 m (10 ft), the check referred to in paragraph 2 will not result in significant differences from the conventional geometric right-angle triangle calculation for threshold distances of less than 8 km or 4 NM. This also applies when distances are rounded to the nearest tenth of a kilometre (NM) for heights less than 500 m or 2 100 ft.

Note 2.— To determine glide path heights at the outer marker fix or other fix, unrounded height values are used.

**Table II-1-1-App C-1a). Fix height over threshold in metres taking account of the curvature of the earth
(reference datum height of 15 m) — SI units**

Glide path angle	Fix distance from threshold (km)																			
	1	2	3	4	5	6	7	8	9	10	11	12	13	14	15	16	17	18	19	20
2.5°	59	103	147	191	235	280	324	369	414	459	505	550	596	642	688	734	780	826	873	920
2.6°	60	106	152	198	244	290	337	383	430	477	524	571	618	666	714	762	810	858	906	955
2.7°	62	110	157	205	253	301	349	397	446	494	543	592	641	691	740	790	839	889	939	990
2.8°	64	113	162	212	262	311	361	411	462	512	562	613	664	715	766	818	869	921	972	1 024
2.9°	66	117	168	219	270	322	373	425	477	529	582	634	687	740	792	846	899	952	1 006	1 060
3.0°	67	120	173	226	279	332	386	439	493	547	601	655	710	764	819	874	929	984	1 039	1 094
3.1°	69	124	178	233	288	343	398	453	509	564	620	676	732	788	845	902	958	1 015	1 072	1 130
3.2°	71	127	183	240	296	353	410	467	524	582	639	697	755	813	871	930	988	1 047	1 106	1 164
3.3°	73	131	189	247	305	364	422	481	540	599	659	718	778	838	898	958	1 018	1 078	1 139	1 200
3.4°	74	134	194	254	315	374	435	495	556	617	678	739	801	862	924	986	1 048	1 110	1 172	1 235
3.5°	76	138	199	261	323	385	447	509	572	634	697	760	823	887	950	1 014	1 077	1 141	1 205	1 270

Glide path angle	Fix distance from threshold (km)																			
	21	22	23	24	25	26	27	28	29	30	31	32	33	34	35	36	37	38	39	40
2.5°	966	1 014	1 061	1 108	1 156	1 203	1 251	1 299	1 347	1 395	1 444	1 492	1 541	1 590	1 639	1 688	1 738	1 787	1 837	1 887
2.6°	1 003	1 052	1 101	1 150	1 199	1 249	1 298	1 348	1 398	1 448	1 498	1 548	1 599	1 650	1 700	1 751	1 803	1 854	1 905	1 957
2.7°	1 040	1 090	1 141	1 192	1 243	1 294	1 346	1 397	1 449	1 500	1 552	1 604	1 657	1 709	1 762	1 814	1 867	1 920	1 974	2 027
2.8°	1 077	1 129	1 181	1 234	1 287	1 340	1 393	1 446	1 499	1 553	1 606	1 660	1 714	1 769	1 823	1 877	1 932	1 987	2 042	2 097
2.9°	1 113	1 167	1 222	1 276	1 330	1 385	1 440	1 495	1 550	1 605	1 661	1 716	1 772	1 828	1 884	1 940	1 997	2 053	2 110	2 167
3.0°	1 150	1 206	1 262	1 318	1 374	1 431	1 487	1 544	1 601	1 657	1 715	1 772	1 830	1 888	1 945	2 003	2 062	2 120	2 178	2 237
3.1°	1 187	1 244	1 302	1 360	1 418	1 476	1 534	1 593	1 652	1 710	1 769	1 828	1 888	1 947	2 007	2 066	2 126	2 186	2 246	2 307
3.2°	1 224	1 283	1 342	1 402	1 462	1 522	1 582	1 642	1 702	1 763	1 824	1 884	1 945	2 007	2 068	2 129	2 191	2 253	2 315	2 377
3.3°	1 260	1 322	1 383	1 444	1 506	1 567	1 629	1 691	1 753	1 815	1 878	1 940	2 003	2 066	2 129	2 192	2 256	2 319	2 383	2 447
3.4°	1 297	1 360	1 423	1 486	1 549	1 613	1 676	1 740	1 804	1 868	1 932	1 996	2 061	2 126	2 190	2 256	2 321	2 386	2 451	2 517
3.5°	1 334	1 398	1 463	1 528	1 593	1 658	1 724	1 789	1 854	1 920	1 986	2 052	2 119	2 185	2 252	2 318	2 385	2 452	2 520	2 587

**Table II-1-1-App C-1b). Fix height over threshold in feet taking account of the curvature of the earth
(reference datum height of 49 ft) — Non-SI units**

Glide path angle	Fix distance from threshold (NM)																			
	1	2	3	4	5	6	7	8	9	10	11	12	13	14	15	16	17	18	19	20
2.5°	315	583	853	1 124	1 398	1 672	1 949	2 228	2 508	2 790	3 074	3 360	3 647	3 936	4 227	4 520	4 814	5 110	5 408	5 708
2.6°	326	604	885	1 167	1 451	1 736	2 024	2 313	2 604	2 896	3 191	3 487	3 785	4 085	4 386	4 690	4 994	5 302	5 610	5 920
2.7°	336	626	916	1 209	1 504	1 800	2 098	2 398	2 699	3 003	3 308	3 615	3 923	4 234	4 546	4 860	5 175	5 493	5 812	6 133
2.8°	347	647	948	1 252	1 557	1 864	2 172	2 483	2 795	3 109	3 425	3 742	4 061	4 382	4 705	5 030	5 356	5 684	6 014	6 346
2.9°	357	668	980	1 294	1 610	1 928	2 247	2 568	2 891	3 215	3 542	3 870	4 200	4 531	4 865	5 200	5 537	5 876	6 216	6 558
3.0°	368	689	1 012	1 336	1 663	1 991	2 321	2 653	2 986	3 322	3 659	3 997	4 338	4 680	5 024	5 370	5 718	6 067	6 418	6 771
3.1°	379	711	1 044	1 379	1 716	2 055	2 396	2 738	3 082	3 428	3 776	4 125	4 476	4 829	5 183	5 540	5 898	6 258	6 620	6 984
3.2°	390	732	1 076	1 422	1 770	2 119	2 470	2 823	3 178	3 534	3 892	4 253	4 614	4 978	5 343	5 710	6 079	6 450	6 822	7 196
3.3°	400	753	1 108	1 464	1 823	2 183	2 545	2 908	3 274	3 640	4 010	4 380	4 753	5 127	5 502	5 880	6 260	6 641	7 024	7 409
3.4°	411	774	1 140	1 507	1 876	2 247	2 619	2 993	3 369	3 747	4 127	4 508	4 891	5 276	5 662	6 051	6 441	6 833	7 226	7 622
3.5°	422	796	1 172	1 550	1 929	2 310	2 694	3 078	3 465	3 854	4 244	4 636	5 029	5 425	5 822	6 221	6 622	7 024	7 428	7 835

Table II-1-1-App C-2a). Distance of final approach point/descent fix before threshold in kilometres taking account of the curvature of the earth (reference datum height of 15 m) — SI units

Glide path angle	Final approach point/descent fix height over threshold (m)														
	100	200	300	400	500	600	700	800	900	1 000	1 100	1 200	1 300	1 400	1 500
2.5°	1 941	4 207	6 455	8 686	10 899	13 096	15 276	17 440	19 588	21 721	23 839	25 942	28 031	30 105	32 166
2.6°	1 866	4 047	6 212	8 361	10 494	12 613	14 717	16 806	18 881	20 942	22 990	25 024	27 045	29 053	31 049
2.7°	1 798	3 899	5 986	8 059	10 118	12 164	14 196	16 215	18 221	20 215	22 197	24 166	26 124	28 069	30 004
2.8°	1 734	3 761	5 776	7 778	9 768	11 745	13 710	15 663	17 605	19 536	21 455	23 363	25 260	27 147	29 023
2.9°	1 674	3 633	5 580	7 516	9 440	11 353	13 255	15 147	17 028	18 899	20 759	22 610	24 450	26 281	28 102
3.0°	1 619	3 513	5 397	7 270	9 133	10 986	12 829	14 663	16 487	18 301	20 106	21 901	23 689	25 467	27 236
3.1°	1 566	3 400	5 225	7 040	8 846	10 642	12 430	14 208	15 978	17 739	19 492	21 236	22 972	24 700	26 419
3.2°	1 518	3 295	5 064	6 824	8 575	10 318	12 053	13 780	15 499	17 209	18 912	20 608	22 295	23 976	25 648
3.3°	1 472	3 196	4 912	6 620	8 321	10 013	11 699	13 376	15 047	16 710	18 366	20 015	21 657	23 292	24 920
3.4°	1 429	3 102	4 769	6 428	8 081	9 726	11 344	12 995	14 620	16 238	17 849	19 454	21 052	22 644	24 230
3.5°	1 388	3 014	4 634	6 247	7 854	9 454	11 048	12 635	14 216	15 791	17 360	18 923	20 480	22 031	23 576

Glide path angle	Final approach point/descent fix height over threshold (m)														
	1 600	1 700	1 800	1 900	2 000	2 100	2 200	2 300	2 400	2 500	2 600	2 700	2 800	2 900	3 000
2.5°	34 212	36 246	38 267	40 274	42 270	44 252	46 223	48 182	50 129	52 064	53 989	55 902	57 804	59 696	61 577
2.6°	33 032	35 003	36 963	38 910	40 846	42 771	44 685	46 588	48 480	50 361	52 232	54 093	55 944	57 785	59 616
2.7°	31 927	33 839	35 740	37 630	39 510	41 380	43 239	45 088	46 928	48 758	50 578	52 389	54 191	55 983	57 767
2.8°	30 889	32 745	34 591	36 427	38 254	40 071	41 878	43 677	45 466	47 247	49 018	50 781	52 536	54 282	56 020
2.9°	29 914	31 717	33 510	35 295	37 071	38 838	40 596	42 346	44 087	45 821	47 546	49 263	48 092	52 674	54 368
3.0°	28 996	30 749	32 492	34 228	35 955	37 674	39 386	41 089	42 785	44 473	46 154	47 827	49 493	51 152	52 803
3.1°	28 131	29 835	31 531	33 220	34 901	36 575	38 241	39 901	41 553	43 198	44 836	46 467	40 092	49 710	51 321
3.2°	27 314	28 972	30 623	32 268	33 904	35 535	37 159	38 776	40 386	41 990	43 581	45 178	46 763	48 341	49 914
3.3°	26 541	28 156	29 764	31 366	32 961	34 550	36 133	37 709	39 280	40 844	42 402	43 955	45 501	47 042	48 577
3.4°	25 809	27 383	28 950	30 511	32 066	33 616	35 159	36 697	38 229	39 756	41 277	42 792	44 302	45 807	47 306
3.5°	25 116	26 649	28 177	29 700	31 217	32 728	34 235	35 736	37 231	38 722	40 207	41 687	43 162	44 632	46 097

**Table II-1-1-App C-2b). Distance of final approach point/descent fix before threshold
in nautical miles taking account of the curvature of the earth
(reference datum height of 49 ft) — Non-SI units**

Glide path angle	Final approach point/descent fix height over threshold (ft)														
	300	600	900	1 200	1 500	1 800	2 100	2 400	2 700	3 000	3 300	3 600	3 900	4 200	4 500
2.5°	943	2 063	3 175	4 278	5 374	6 462	7 543	8 616	9 682	10 741	11 793	12 838	13 877	14 909	15 934
2.6°	907	1 985	3 055	4 118	5 174	6 223	7 265	8 301	9 330	10 353	11 370	12 380	13 385	14 384	15 376
2.7°	874	1 912	2 944	3 969	4 988	6 000	7 007	8 008	9 003	9 992	10 976	11 953	12 926	13 893	14 855
2.8°	843	1 844	2 840	3 830	4 814	5 793	6 766	7 734	8 697	9 654	10 606	11 554	12 496	13 433	14 366
2.9°	814	1 781	2 743	3 700	4 652	5 599	6 541	7 478	8 410	9 338	10 261	11 179	12 093	13 002	13 907
3.0°	786	1 722	2 653	3 579	4 501	5 418	6 330	7 238	8 142	9 041	9 936	10 827	11 714	12 597	13 475
3.1°	761	1 667	2 569	3 466	4 359	5 248	6 132	7 063	7 890	8 762	9 631	10 496	11 358	12 215	13 069
3.2°	738	1 615	2 489	3 359	4 225	5 088	5 946	6 801	7 652	8 500	9 344	10 184	11 022	11 855	12 685
3.3°	715	1 567	2 414	3 259	4 100	4 937	5 771	6 601	7 428	8 252	9 073	9 890	11 704	11 515	12 323
3.4°	694	1 521	2 344	3 164	3 981	4 795	5 605	6 413	7 217	8 018	8 818	9 612	10 404	11 194	11 980
3.5°	674	1 477	2 278	3 075	3 869	4 660	5 449	6 234	7 017	7 797	8 574	9 349	10 120	10 889	11 655

Glide path angle	Final approach point/descent fix height over threshold (ft)														
	4 800	5 100	5 400	5 700	6 000	6 300	6 600	6 900	7 200	7 500	7 800	8 100	8 400	8 700	9 000
2.5°	16 954	17 967	18 974	19 975	20 970	21 960	22 994	23 922	24 895	25 862	26 824	27 781	28 733	29 680	30 622
2.6°	16 364	17 345	18 321	19 292	20 257	21 217	22 172	23 121	24 066	25 006	25 941	26 871	27 796	28 717	29 633
2.7°	15 812	16 764	17 710	18 651	19 588	20 520	21 447	22 369	23 287	24 200	25 109	26 014	26 914	27 810	28 702
2.8°	15 294	16 217	17 136	18 050	18 959	19 864	20 765	21 662	22 554	23 442	24 326	25 206	26 082	26 954	27 823
2.9°	14 808	15 704	16 596	17 484	18 368	19 247	20 123	20 995	21 863	22 727	23 588	24 444	25 297	26 147	26 992
3.0°	14 350	15 221	16 088	16 951	17 810	18 666	19 518	20 366	21 211	22 052	22 890	23 724	24 555	25 383	26 207
3.1°	13 919	14 766	15 609	16 448	17 284	18 117	18 946	19 772	20 595	21 414	22 230	23 043	23 853	24 660	25 463
3.2°	13 512	14 336	15 156	15 973	16 787	17 598	18 405	19 210	20 011	20 810	21 605	22 398	23 187	23 974	24 758
3.3°	13 128	13 930	14 728	15 524	16 317	17 106	17 893	18 677	19 458	20 237	21 013	21 786	22 556	23 324	24 089
3.4°	12 764	13 545	14 323	15 098	15 871	16 641	17 408	18 172	18 934	19 694	20 450	21 205	21 957	22 706	23 453
3.5°	12 419	13 180	13 938	14 694	15 448	16 198	16 947	17 693	18 436	19 177	19 916	20 652	21 386	22 118	22 848

Appendix D to Chapter 1

INDEPENDENT PARALLEL APPROACHES TO CLOSELY SPACED PARALLEL RUNWAYS

1. INTRODUCTION

1.1 Independent parallel approaches to closely spaced parallel runways are allowed when the distance between runways is not less than 1 035 m. To guarantee the safety of such operations, an obstacle assessment has to be carried out to protect a lateral break-out manoeuvre, which may need to be executed to avoid collision with a potential blundering aircraft. This will provide obstacle clearance from obstacles in the areas adjacent to the final approach segments.

1.2 The following method provides an example for the assessment of these obstacles and was derived from an existing procedure used by one State. This section includes the considerations made in developing the basis for the assessment.

1.3 It was considered that a difference exists between the current precision approach procedures described in Chapter 1, “Instrument landing system (ILS)” and Chapter 3, “MLS”, and the break-out procedures. For the approach procedures, an extensive data collection could be performed from which statistical probabilities of aircraft distributions could be obtained. In establishing a target level of safety (TLS) of 10^{-7} , obstacle assessment surfaces (OAS) and the collision risk model (CRM) are derived. For the assessment surfaces of the break-out manoeuvre, this type of method was not considered feasible due to the low probability of occurrence of a break-out manoeuvre. From one State’s report, it was learned that the occurrence of a break-out during simultaneous approaches was initially assumed to be in the order of 10^{-4} and 10^{-5} per approach and may even be lower.

1.4 In order to find obstacle clearance criteria for break-out manoeuvres, other methods were considered. One way was to use the existing missed approach criteria. However, these criteria are based on an occurrence of 10^{-2} which may be unduly restrictive at some aerodromes, and missed approaches are not primarily designed for break-out manoeuvres.

2. PARALLEL APPROACH OBSTACLE ASSESSMENT SURFACES (PAOAS)

2.1 The proposed method for the obstacle assessment for simultaneous parallel approaches was based on existing criteria provided by one State (FAA Order 8260.41). An evaluation was carried out by the Obstacle Clearance Panel (OCP). This evaluation was made by means of certification and operational criteria contained in the FAR/JAR 23/25 minimum climb requirements with all engines operating, together with the operational assumptions made by the ICAO Study Group on Simultaneous Operations on Parallel or Near-parallel Instrument Runways (SOIR), which established the minimum runway separation for use with simultaneous independent precision approaches (Cir 207). The evaluation considered that the initial part of the break-out manoeuvre would be executed in the landing configuration, followed by a climb gradient of 8.3 per cent within a height of 120 m (400 ft) above the break-out altitude/height. This evaluation indicated, in general, that the following restrictions to the break-out manoeuvres were necessary:

- a) no break-out manoeuvres below 120 m (400 ft); and
- b) maximum 45° break-out angle.

2.2 Due to the nature of the surfaces, these two parameters are interdependent. During the evaluation, it was found that the lower the break-out was considered, the earlier the assessment surfaces would be penetrated, causing the break-out angle to be reduced, e.g. a minimum break-out height of 60 m (200 ft) would result in a break-out angle of 20°, and a minimum break-out height of 300 m (1 000 ft) would result in a break-out angle of 65°.

2.3 It was considered necessary to restrict the minimum break-out altitude/height. One reason was that break-out manoeuvres at too low heights could be considered unsafe. Moreover, considering the maximum assumed blunder angle of 30° and approach speed of 150 kt, it could be assumed that below a certain height the blundering aircraft could not reach the threatened aircraft before it landed. and therefore it would be of no use to protect for these low heights.

2.4 Information available in respect of flight and simulator tests conducted by one State for these manoeuvres showed that phraseology used by the air traffic services (ATS) was similar to that contained in the PANS-ATM, Chapter 12, on independent parallel approaches. Following the instructions from air traffic services, the pilot actually first arrested the descent and then established climb, crossing the glide path (if below) before turning. This information supported the assumptions used to validate the proposed obstacle assessment criteria.

2.5 The evaluation report further indicated that it was not considered convenient to provide additional obstacle assessment surface (OAS) constant tables in PANS-OPS for these cases for each localizer-threshold distance combination. The proposed surfaces are based on operational rather than statistical considerations. Therefore, it was proposed to use one set of surfaces for all combinations of localizer-threshold distances. These surfaces would guarantee protection for aircraft following the assumed operational scenario.

2.6 A mathematical match was made from the surfaces for an average runway length/localizer distance contained in the Federal Aviation Administration (FAA) Order (8260.41). This approach was considered acceptable for the assessment of rare events for which statistical analysis was not feasible.

3. APPLICATION OF PARALLEL APPROACH OBSTACLE ASSESSMENT SURFACE (PAOAS) CRITERIA

3.1 General

In addition to the application of OAS criteria specified in Chapter 1, 1.4.8, “Obstacle clearance of the precision segment using (OAS) criteria,” parallel approach obstacle assessment surfaces (PAOAS) are defined to safeguard the execution of an immediate climb and turn manoeuvre to the assigned heading and altitude/height. PAOAS criteria are used to demonstrate obstacle clearance, accommodating turns up to 45° from the approach path and a lowest break-out manoeuvre initiation of 120 m (400 ft) above threshold elevation. PAOAS criteria are valid for all categories of instrument landing system/microwave landing system (ILS/MLS) approaches.

3.2 Definition of surfaces

3.2.1 The PAOAS consists mainly of two sloping plane surfaces (denoted P1 and P2) positioned on the side of the runway opposite to the adjacent runway. The geometry of the sloping surfaces is defined, similar to the OAS surfaces (see Chapter 1, 1.4.8.4, “Definition of obstacle assessment surfaces (OAS)”) by a linear equation of the form $z = Ax + By + C$. The constants are related to the glide path angle only. They are independent of the category of ILS/MLS operations and localizer-threshold distance. The constants are given in Table II-1-1-App D-1.

3.2.2 Where the OAS surfaces are below P1 or P2, they become the PAOAS. Where the Z surface is above the PAOAS, it becomes the PAOAS. A typical example of the layout of combined OAS and PAOAS surfaces is depicted in Figure II-1-1-App D-1. The surfaces terminate at a height of 300 m (1 000 ft) below minimum altitude/height associated with tactical radar vectoring.

3.3 Calculation of PAOAS height

To calculate the height z of P1 or P2 surfaces at a location x' , y' , the appropriate constants should be obtained from Table II-1-1-App D-1 and substituted in the equation $z = Ax' + By' + C$. Similarly, the height of the OAS surfaces should be calculated according to Chapter 1, 1.4.8. The height of the PAOAS is then determined as specified in 3.2, “Definition of surfaces,” above.

3.4 Obstacle assessment

3.4.1 The obstacle elevation/height in the area to be considered shall be less than the PAOAS height as specified in 3.2, “Definition of surfaces,” above. Obstacles below the Z surface, or its extension, need not be considered. PAOAS penetrations shall be identified and considered for electronic mapping on controller displays.

3.4.2 If possible, obstacles should be removed. Where obstacle removal is not feasible, air traffic operational rules shall be established to avoid obstacles, and a risk assessment shall be required to provide guidance on whether independent simultaneous ILS/MLS operations to parallel runways should be approved.

Table II-1-1-App D-1. Constants for calculation of PAOAS

PAOAS	A	B	C
P1	$\tan \theta$	0.091	5
P2	0	0.091	15

θ = ILS glide path angle or MLS elevation angle

PAOAS coordinates in metres

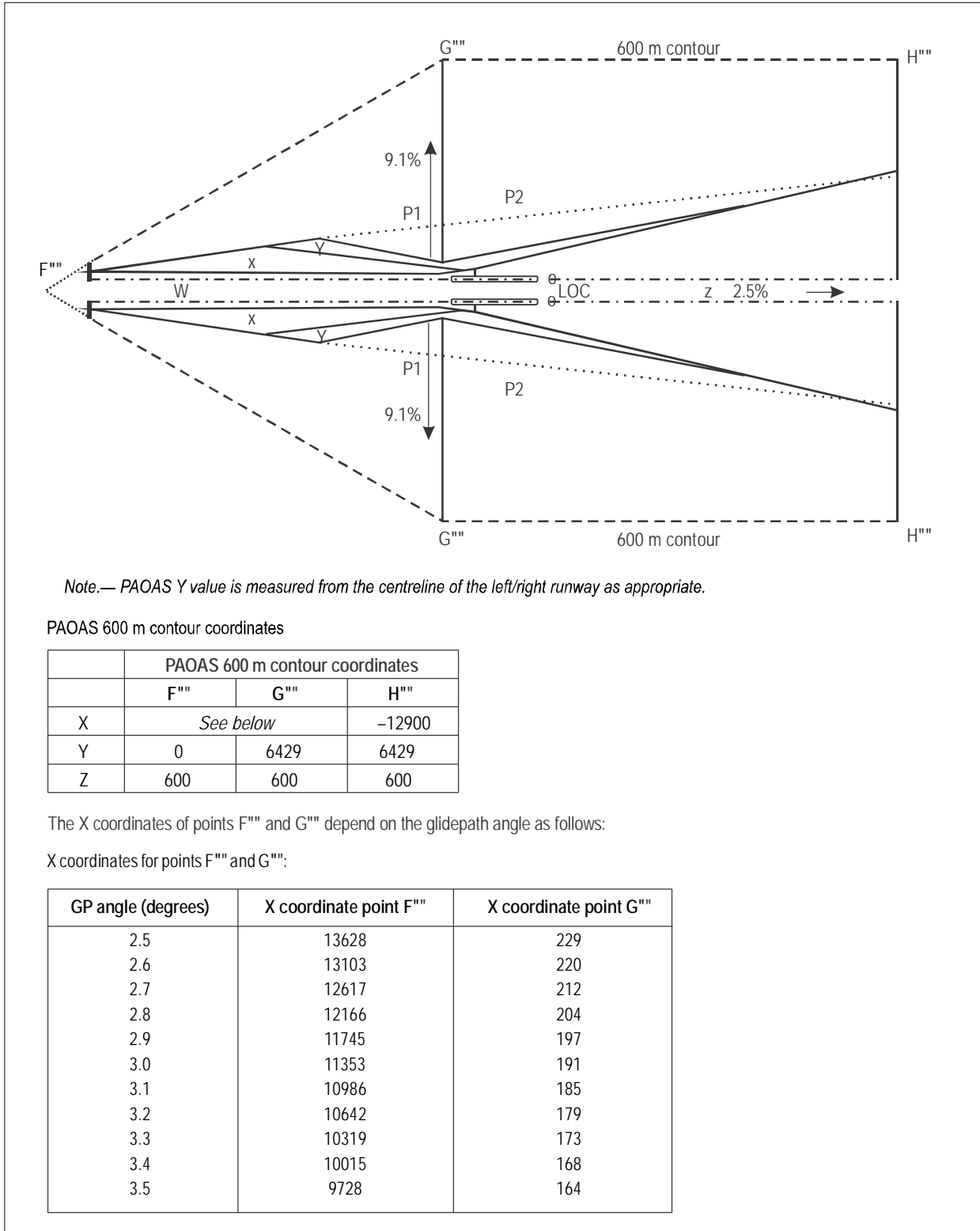

Figure II-1-1-App D-1. Example of PAOAS and OAS contours

Appendix E to Chapter 1

CALCULATION OF OBSTACLE ASSESSMENT SURFACE HEIGHT

Editorial Note.— The table previously contained in Attachment I has been replaced by the PANS-OPS OAS software (ICAO public website (www.icao.int) under “Publications”).

The PANS-OPS OAS software provides the calculation of the Obstacle Assessment Surfaces (OAS) parameters for specific ILS/MLS/GLS geometry, aircraft dimensions and missed approach climb gradient, and calculates the height of the OAS surface (Z) above a specific location (X, Y) for the selected system and aircraft parameters. The programme prints the parameters and results for any specific set of conditions and also all or any individual pages of the table previously contained in Attachment I to Part III (Doc 8168, Volume II, Amdt. 11).

Chapter 2

OFFSET ILS

2.1 USE OF ILS CAT I WITH OFFSET LOCALIZER ALIGNMENT

2.1.1 The localizer course line shall intersect the runway extended centre line:

- a) at an angle not exceeding 5° ; and
- b) at a point where the nominal glide path reaches a height of at least 55 m (180 ft) above threshold. This is called intercept height.

2.1.2 The procedure shall be annotated: “localizer offset ... degrees” (tenth of degrees). The general arrangement is shown in Figure II-1-2-1.

2.2 OBSTACLE CLEARANCE CRITERIA

The provisions contained in Chapter 1 apply except that:

- a) all the obstacle clearance surfaces and calculations are based on a fictitious runway aligned with the localizer course. This fictitious runway has the same length, the same threshold elevation, and the same distance threshold to intercept point as the real one. The localizer course width and the ILS reference datum height are based on the threshold of the fictitious runway; and
- b) the OCA/H for this procedure shall be at least: intercept altitude/height + 20 m (66 ft).

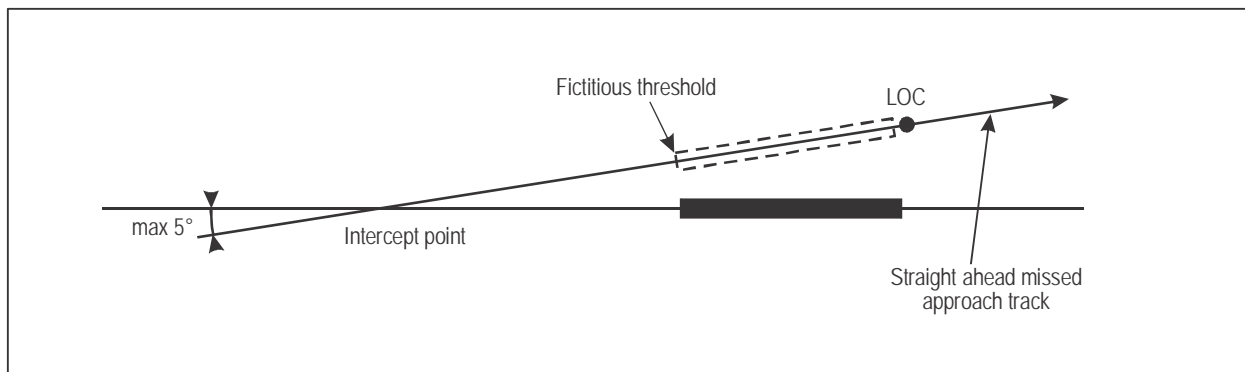

Figure II-1-2-1. Offset localizer

Chapter 3

MLS

3.1 INTRODUCTION

3.1.1 Application

The MLS criteria in this part are based on ILS criteria and are related to the ground and airborne equipment performance and integrity required to meet the Standards and Recommended Practices described in Annex 10. The following criteria apply to MLS Category I, II and III procedures based on the zero-degree azimuth and a glide path (elevation angle) of the MLS ground equipment and are intended for application pending the introduction of specific MLS criteria to be developed on the basis of further operational experience.

3.1.2 Procedure construction

The procedure from en-route to the precision segment of the MLS approach conforms to the general criteria in as Part I, Sections 1, 2 and 4. The differences are found in the MLS precision segment which contains the final approach segment and the initial/intermediate phases of the missed approach segment. The final approach track for the MLS procedure is always specified and promulgated in degrees magnetic. Figure II-1-3-1 (for MLS Category I, II and III) shows a typical layout where the final approach track is defined by the MLS zero-degree azimuth and is aligned with the runway extended centre line.

3.1.3 Standard conditions

The following list contains the standard assumptions on which procedures are developed. Provisions are made for adjustments where appropriate. Adjustments are mandatory when conditions differ adversely from standard conditions (see 3.4.8.7, “Adjustment of OAS constants”).

- a) Maximum aircraft dimensions are assumed to be the following:

<i>Aircraft category</i>	<i>Wingspan</i>	<i>Vertical distance between the flight paths of the wheels and the GP antenna (m)</i>
H	30	3
A, B	60	6
C, D	65	7
D _L	80	8

Note 1.— OCA/H for D_L aircraft is published when necessary.

Note 2.— The dimensions shown are those which encompass current aircraft types. They are chosen to facilitate OCA/H calculations and promulgation of aircraft category related minima. It is assumed that these dimensions are not intended to be used for other purposes than the OCA/H calculations in other ICAO documents. The use of OAS surfaces to calculate OCA/H may result in significant differences between aircraft categories because of small differences in size. For this reason, it is always preferable to use the Collision Risk Model (3.4.9) which will allow for more realistic assessment for both height and position of obstacles. When applying OAS methodology to determine OCH, new larger aircraft with performance as demonstrated in ICAO Circular 301 may be treated as standard Category C or D aircraft, without correcting the OAS for wingspan and/or vertical dimension.

Note 3.— Current Category E aircraft are not normally civil transport aircraft and their dimensions are not necessarily related to Vat at maximum landing mass. For this reason, they should be treated separately on an individual basis.

- b) Category II/III is flown autocoupled (for Category II flown with flight director, see 3.4.8.7.6).
- c) Missed approach climb gradient 2.5 per cent.
- d) The approach azimuth deviation information is displayed using sensitivity characteristics in accordance with the following table (Annex 10, Volume I, Attachment G, 7.4.1.1).

<i>Approach azimuth antenna to threshold distance (ATT)</i>	<i>Nominal course width</i>
0 – 400 m	± 3.6 degrees
500 – 1 900 m	± 3.0 degrees
2 000 – 4 100 m	± arctan $\left(\frac{105}{ATT}\right)$ degrees
4 200 – 6 300 m	± 1.5 degrees

Note.— The displacement sensitivity characteristics given above for the ATT distances from 2 000 m to 4 100 m are based upon a nominal course width of 210 m at the MLS approach reference datum.

- e) Glide path (elevation angle):
 - 1) minimum: 2.5°;
 - 2) optimum: 3.0°; and
 - 3) maximum: 3.5° (3° for Cat II/III operations).

Note.— The glide path angle of the procedure must be greater than or equal to the minimum glide path (see Annex 10, Volume I, Chapter 3, 3.11.1 — Definitions).

- f) MLS approach reference datum height 15 m (50 ft).
- g) All obstacle heights are referenced to threshold elevation.
- h) For Cat II and Cat III operations the Annex 14 inner approach, inner transitional, and balked landing surfaces have not been penetrated. Where the Cat II OCA/H is higher than the level of the inner horizontal surface, but

below 60 m, Category III operations can be accommodated provided the inner approach, inner transitional and balked landing surfaces are extended to the Cat II OCA/H level (see Figure II-1-3-9 a)).

When azimuth antenna to threshold distance is less than 2 000 m, the obstacle assessment surface (OAS) tables for a 2 000 m localizer to threshold are to be used. When using the ILS CRM or the OAS table, the ATT distances and displacement sensitivity characteristics shown in 3.1.3 d) above are to be used.

3.1.4 Obstacle clearance altitude/height (OCA/H)

3.1.4.1 The MLS criteria enable an OCA/H to be calculated for each category of aircraft. See Part I, Section 4, Chapter 1, 1.8, “Categories of aircraft”. Where statistical calculations were involved, the OCA/H values were designed against an overall safety target of 1×10^{-7} (1 in 10 million) per approach for risk of collision with obstacles.

3.1.4.2 The OCA/H ensures clearance of obstacles from the start of the final approach to the end of the intermediate missed approach segment.

Note.— This OCA/H is only one of the factors to be taken into account in determining decision height as defined in Annex 6.

3.1.4.3 Additional material is included to allow operational benefit to be calculated for the improved missed approach climb performance in Cat I, II and III.

3.1.4.4 Benefit may also be calculated for aircraft with dimensions smaller than the standard size assumed in the basic calculations and adjustments must be made for larger aircraft. An OCA/H is not associated with Cat III operations. These are supported by the obstacle limitation surfaces defined in Annex 14, in association with overlapping protection from the Cat II criteria.

3.1.5 Methods of calculating OCA/H

3.1.5.1 *General.* Three methods of calculating OCA/H are presented, which involve progressive increases in the degree of sophistication in the treatment of obstacles. Standard conditions (as specified in 3.1.3) are assumed to exist unless adjustments for non-standard conditions have been made.

3.1.5.2 *First method.* The first method involves a set of surfaces derived from the Annex 14 precision approach obstacle limitation surfaces and a missed approach surface described in 3.4.7.2, “Definition of basic ILS surfaces”. From this point forward, these are termed “basic ILS surfaces”. Where the standard conditions exist as specified in 3.1.3 and where the basic ILS surfaces are free of penetrations (see 3.4.7.1), the OCA/H for Cat I and Cat II is defined by aircraft category margins, and there are no restrictions on Cat III operations. If the basic ILS surfaces are penetrated, then the OCA/H is calculated as described in 3.4.7.3, “Determination of OCA/H with basic ILS surfaces”.

3.1.5.3 *Second method.* The second method involves a set of obstacle assessment surfaces (OAS) above the basic ILS surfaces (see 3.4.8.3, “Definition of obstacle assessment surfaces (OAS)”). If the OAS are not penetrated, — and provided the obstacle density below the OAS is operationally acceptable (see 3.4.8.9, “Effect of obstacle density on OCA/H”) — the OCA/H for Cat I and Cat II is still defined by the aircraft category margins, and Cat III operations remain unrestricted. However, if the OAS are penetrated, then an aircraft category-related margin is added to the height of the highest approach obstacle, or to the adjusted height of the largest missed approach penetration, whichever is greater. This value becomes the OCA/H.

3.1.5.4 *Third method.* The third method, using the ILS collision risk model (CRM), is employed either as an alternative to the use of the OAS criteria (second method) or when the obstacle density below the OAS is considered to be excessive. The ILS CRM accepts all objects as an input and assesses, for any specific OCA/H value, both the risk

due to individual obstacles and the accumulated risk due to all the obstacles. In this way it assists operational judgement in the choice of an OCA/H value which will ensure that the hazard due to obstacles, both individually and collectively, can be contained within the overall safety target.

3.1.6 References

The following appendices relate to and amplify the material contained in this chapter:

- a) background information relating to the derivation of the OAS material (Attachment to Part II, paragraph 1) and to airborne and ground equipment performance assumed in the derivation of the OAS (Attachment to Part II, paragraph 2);
- b) turning missed approach after precision approach (Appendix A to Chapter 1);
- c) independent parallel approaches to closely spaced parallel runways (Appendix D to Chapter 1);
- d) determining ILS glide path descents/MLS elevation heights and distances (Appendix C to Chapter 1); and
- e) PANS-OPS OAS software (ICAO public website (www.icao.int) under “Publications”).

Examples of OCA/H calculation for ILS can be found in *Instrument Flight Procedures Construction Manual* (Doc 9368).

3.1.7 MLS with glide path inoperative

The MLS with glide path inoperative is a non-precision approach procedure. The principles of Section 2, Chapter 2, “MLS azimuth only”, apply.

3.2 INITIAL APPROACH SEGMENT

3.2.1 General

The initial approach segment for MLS must ensure that the aircraft is positioned within the operational service volume of the azimuth on a track that will facilitate azimuth interception. Consequently, the general criteria applicable to the initial segment (see Part I, Section 4, Chapter 3) are modified in accordance with 3.2.2, “Initial approach segment alignment” and 3.2.3, “Initial approach segment area”, below. The initial approach segment may be defined by an RNAV or RNP route, using an RNAV or RNP system for track guidance. Only the systems capable of navigation accuracy of 1 NM or better in this phase of flight can be considered. Refer to Part III, Section 1, Chapter 1, Table III-1-1-1 for the navigation specifications that can be used for initial approach. The RNAV or RNP route shall terminate at an IF defined by RNAV or RNP located on the azimuth course. RNAV/RNP turn construction is applicable for turns within the initial segment and for the turn at the IF on the azimuth course (see Figures II-1-3-6 and II-1-3-7). For RNAV and RNP initial approach segments, criteria in Part III apply. If a course reversal is required with an RNAV or RNP initial approach segment, only a racetrack can be used. The fix and the inbound leg shall be located on the azimuth course and the inbound segment defined by the azimuth.

3.2.2 Initial approach segment alignment

The angle of interception between the initial approach track and the intermediate track should not exceed 90°. In order to permit the autopilot to couple on to the azimuth, an interception angle not exceeding 30° is desirable. When the angle

exceeds 70°, a radial, bearing, radar vector, or DME information providing at least 4 km (2 NM) of lead shall be identified to assist the turn onto the intermediate track. When the angle exceeds 90°, the use of a reversal, racetrack, or dead reckoning (DR) track procedure should be considered (see Part I, Section 4, Chapter 3, “Initial approach segment” and Part I, Section 4, Appendix A to Chapter 3, “Initial approach using dead reckoning (DR)”).

3.2.3 Initial approach segment area

The area is as described in the general criteria (see Part I, Section 4, Chapter 3, 3.3.3, “Area”). The difference is that the intermediate approach fix (IF) must be located within the service volume of the MLS azimuth signal, and normally at a distance not exceeding 41.7 km (22.5 NM) from the azimuth antenna. When radar is used to provide track guidance to the IF, the area shall be in accordance with 6.2, “Initial approach segment” (Section 2, Chapter 6, “SRE”).

3.3 INTERMEDIATE APPROACH SEGMENT

3.3.1 General

3.3.1.1 The intermediate approach segment for MLS differs from the general criteria in that:

- a) the alignment coincides with the MLS azimuth specified for final approach track;
- b) the length may be reduced; and
- c) in certain cases the secondary areas may be eliminated.

3.3.1.2 The primary and secondary areas at the FAP are defined in terms of the ILS surfaces. Consequently, the general criteria in Part I, Section 4, Chapter 4, “Intermediate approach segment” are applied except as modified or amplified in the paragraphs below with regards to alignment, area length and width, and for obstacle clearance. For RNAV initial approach segments, the criteria in the applicable RNAV chapters apply.

3.3.2 Intermediate approach segment alignment

The intermediate approach segment of an MLS procedure shall be aligned with the MLS azimuth specified for the final approach track.

3.3.3 Intermediate approach segment length

3.3.3.1 The optimum length of the intermediate approach segment is 9 km (5 NM). This segment shall allow interception with the final approach track and with the glide path (MLS elevation angle).

3.3.3.2 Segment length should be sufficient to permit the aircraft to stabilize and establish its course on the final approach track prior to intercepting the glide path (MLS elevation angle), taking into consideration the angle of interception of the final approach track.

3.3.3.3 Minimum values for distance between interception of final approach track and interception of glide path are specified in Table II-1-3-1; however, these minimum values should only be used if usable airspace is restricted. The maximum length of the segment is governed by the requirement that it be located wholly within the operational coverage region of the approach azimuth, and normally at a distance not exceeding 37 km (20 NM) from the runway threshold.

3.3.4 Intermediate approach segment area width

3.3.4.1 The total width at the beginning of the intermediate approach segment is defined by the final total width of the initial approach segment. It tapers uniformly to match the horizontal distance between the OAS X surfaces at the FAP (see 3.4.8.3, “Definition of obstacle assessment surfaces (OAS)”).

3.3.4.2 For obstacle clearance purposes the intermediate approach segment is usually divided into a primary area bounded on each side by a secondary area. However, when a DR track is used in the initial approach segment, the primary area of the intermediate approach segment extends across its full width and secondary areas are not applied.

3.3.4.3 The primary area is determined by joining the primary initial approach area with the final approach surfaces (at the FAP). At the interface with the initial approach segment the width of each secondary area equals half the width of the primary area. The secondary area width decreases to zero at the interface with the final approach surfaces. See Figures II-1-3-2, II-1-3-3 and II-1-3-4.

3.3.4.4 Where a racetrack or reversal manoeuvre is specified prior to intercepting the final approach track, the provisions in Part I, Section 4, Chapter 4, 4.4.4, “Turn not at the facility” apply, the facility being the MLS azimuth itself and the FAF being replaced by the FAP (see Figure II-1-3-5).

3.3.5 Intermediate approach segment obstacle clearance

The obstacle clearance is the same as defined in Part I, Section 4, Chapter 4, “Intermediate approach segment” except where the procedure permits a straight-in approach in which the aircraft is stabilized on the final approach track prior to crossing the IF. In this case, obstacles in the secondary areas need not be considered for the purpose of obstacle clearance.

3.4 PRECISION SEGMENT

3.4.1 General

The precision segment for MLS is aligned with the specified MLS azimuth and contains the final descent for landing as well as the initial and intermediate phases of the missed approach segment. Criteria are generally the same as for ILS, except as amended below. See Figure II-1-3-8.

3.4.2 Origin

The precision segment starts at the final approach point (FAP), that is, the intersection of the glide path (elevation angle) and the minimum altitude specified for the preceding segment. The FAP should not normally be located more than 18.5 km (10.0 NM) before threshold. This distance may be extended for operational requirements provided that:

- a) adequate guidance is available; and
- b) obstacle clearance requirements are not compromised (extension of the W and X surfaces of the OAS).

3.4.3 Descent fix

3.4.3.1 A descent fix may be located at the FAP to overcome certain obstacles located before the FAP as an alternative to increasing the glide path (GP) angle. When so located, it becomes the final approach fix, linking the

MOC in the preceding segment smoothly with the precision surfaces. The descent fix should not normally be located more than 18.5 km (10.0 NM) before threshold, unless adequate glide path guidance beyond the minimum specified in Annex 10 is provided. The maximum fix tolerance is ± 0.9 km (± 0.5 NM). The range shall be stated in tenths of kilometres (nautical miles).

Note.— *Guidance material for determining the distance to the descent fix from the threshold is contained in Chapter 1, Appendix C.*

3.4.3.2 Obstacle clearance at the descent fix. When a descent fix is provided, the precision approach surfaces start at the earliest point of the FAF tolerance area (see Figure II-1-3-3). The provisions of Part I, Section 2, Chapter 2, 2.7.4, “Obstacle close to a final approach fix or stepdown fix” which allow obstacles close to the fix to be ignored, apply in the area below the 15 per cent gradient within the precision surfaces (Cat H, 15 per cent gradient or the nominal gradient multiplied by 2.5, whichever is greater). Where a descent fix is not provided at the FAP, no curtailment of the precision surfaces is permitted (see Figure II-1-3-4). If the precision surfaces are extended into the preceding segment, they shall not be extended beyond the intermediate approach segment.

3.4.4 Glide path verification check

A DME fix is necessary so as to permit comparison between the indicated glide path (elevation angle) and the aircraft altimeter information. The fix shall not have a fix tolerance exceeding ± 0.9 km (± 0.5 NM). The range shall be stated in tenths of kilometres (nautical miles).

Note.— *Guidance material for determining the height crossing the DME fix is contained in Chapter 1, Appendix C.*

3.4.5 Missed approach

The missed approach point is defined by the intersection of the nominal glide path and the decision altitude/height (DA/H). The DA/H is set at or above the OCA/H, which is determined as specified in 3.4.7 to 3.4.9 and 3.5.

3.4.6 Termination

The precision segment normally terminates at the point where the final phase of the missed approach commences (see Part I, Section 4, Chapter 6, 6.1.2, “Phases of missed approach segment”) or where the missed approach climb surface Z (starting 900 m past threshold) reaches a height of 300 m (984 ft) above threshold, whichever is lower.

3.4.7 Obstacle clearance in the precision segment application of basic ILS surfaces

3.4.7.1 General. The area required for the precision segment is bounded overall by the basic ILS surfaces defined in 3.4.7.2, below. In standard conditions there is no restriction on objects beneath these surfaces (see 3.1.3, “Standard conditions”). Objects or portions of objects that extend above these surfaces must be either:

- a) minimum mass and frangible; or
- b) taken into account in the calculation of the OCA/H.

3.4.7.2 Definition of basic ILS surfaces. The surfaces to be considered correspond to a subset of Annex 14 obstacle limitation surfaces as specified for precision approach runway code numbers 3 or 4 (see Figure II-1-3-9 b)). These are:

- a) the approach surface, continuing to the final approach point (FAP) (first section 2 per cent gradient, second section 2.5 per cent as described in Annex 14);
- b) the runway strip assumed to be horizontal at the elevation of the threshold;
- c) the missed approach surface. This is a sloping surface which:
 - 1) starts at a point 900 m past threshold at threshold elevation;
 - 2) rises at a 2.5 per cent gradient; and
 - 3) splays so as to extend between the transitional surfaces.

It extends with constant splay to the level of the inner horizontal surface. Thereafter, it continues at the same gradient but with a 25 per cent splay until the termination of the precision segment; and

- d) the extended transitional surfaces, which continue longitudinally along the sides of the approach and missed approach surfaces and up to a height of 300 m above threshold elevation.

3.4.7.3 *Determination of OCA/H with basic ILS surfaces*

3.4.7.3.1 Where the basic ILS surfaces specified in 3.4.7.2 are not penetrated, the OCA/H for Category I and Category II is defined by the margins specified in Table II-1-3-2, and Category III operations are not restricted. Obstacles may be excluded when they are below the transitional surface defined by Annex 14 for runways with code numbers 3 and 4, regardless of the actual runway code number (i.e., the surfaces for code numbers 3 and 4 are used for the obstacle assessment on runways with code numbers 1 and 2).

3.4.7.3.2 If the basic ILS surfaces listed above are penetrated by objects other than those listed in Table II-1-3-3 the OCA/H may be calculated directly by applying height loss/altimeter margins to obstacles (see 3.4.8.8.2, “Calculation of OCA/H values with OAS”).

3.4.7.3.3 The obstacles in Table II-1-3-3 may only be exempted if the following two criteria are met:

- a) the nominal course has the standard width of 210 m (see 3.1.3, “Standard conditions”); and
- b) the MLS Category I decision height is not less than 60 m (200 ft) or the MLS Category II decision height is not less than 30 m (100 ft).

3.4.7.3.4 An object which penetrates any of the basic ILS surfaces and becomes the controlling obstacle, but which must be maintained because of its function with regards to air navigation requirements, may be ignored under certain circumstances in calculating the OCA/H with the following provision. It must be established by the appropriate authority that the portion which penetrates the surface is of minimum mass and frangibly mounted and would not adversely affect the safety of aircraft operations.

3.4.8 Obstacle clearance in the precision segment using obstacle assessment surface (OAS) criteria

3.4.8.1 *General*

3.4.8.1.1 This section describes the OAS surfaces, the constants which are used to define these surfaces, and the conditions under which adjustments may or must be made. The OAS dimensions are related to:

- a) the MLS geometry (azimuth antenna-threshold distance, MLS RDH, azimuth antenna sector width), glide path (elevation angle);
- b) the category of MLS operation; and
- c) other factors, including aircraft geometry, missed approach climb gradient.

Thus, a table of OCA/H values for each aircraft category may be calculated for Cat I and II MLS operations at the particular airfield.

3.4.8.1.2 Additional material is included to enable appropriate authorities to assess realistic benefits for claims of improved performance and associated conditions. See 3.4.8.7, “Adjustment of OAS constants”.

3.4.8.1.3 Note that the OAS are not intended to replace Annex 14 surfaces as planning surfaces for unrestricted obstacle growth. The obstacle density between the basic ILS surfaces and the OAS must be accounted for (see 3.4.8.9, “Effect of obstacle density on OCA/H”).

3.4.8.2 *Frame of reference*

Positions of obstacles are related to a conventional x, y, z coordinate system with its origin at threshold. See Figure II-1-3-13. The x axis is parallel to the precision segment track: positive x is distance before threshold and negative x is distance after threshold. The y axis is at right angles to the x axis. Although shown conventionally in Figure II-1-3-13, *in all calculations associated with OAS geometry, the y coordinate is always counted as positive*. The z axis is vertical, heights above threshold being positive. All dimensions connected with the OAS are specified in metres only. The dimensions should include any adjustments necessary to cater for tolerances in survey data (see Part I, Section 2, Chapter 1, 1.8, “Charting accuracy”).

3.4.8.3 *Definition of obstacle assessment surfaces (OAS)*

3.4.8.3.1 The OAS consist of six sloping plane surfaces (denoted by letters W, X, Y and Z) arranged symmetrically about the precision segment track, together with the horizontal plane which contains the threshold (see Figures II-1-3-11 and II-1-3-12). The geometry of the sloping surfaces is defined by four linear equations of the form $z = Ax + By + C$. In these equations x and y are position coordinates and z is the height of the surface at that position (see Figure II-1-3-10).

3.4.8.3.2 For each surface a set of constants (A, B and C) are obtained from the PANS-OPS OAS software for operational range of localizer threshold distances and glide path angles. Separate sets of constants are provided for Category I and II. These constants may be modified by the programme as specified (see 3.4.8.7, “Adjustment of OAS constants”).

3.4.8.3.3 The Category I OAS are limited by the length of the precision segment and, except for the W and X surfaces, by a maximum height of 300 m. The Category II OAS are limited by a maximum height of 150 m.

3.4.8.3.4 Where the Annex 14 approach and transitional obstacle limitation surfaces for code number 3 and 4 precision approach runways penetrate the OAS, the Annex 14 surfaces become the OAS (i.e. the surfaces for code numbers 3 and 4 are used for obstacle assessment on runways with code numbers 1 and 2).

3.4.8.3.5 The Annex 14 inner approach, inner transitional and balked landing obstacle limitation surfaces protect Category III operations, provided the Category II OCA/H is at or below the top of those surfaces, which may be extended up to 60 m if necessary (see Figure II-1-3-9 b)).

3.4.8.4 OAS constants — specification

For Category I and II operations the constants A, B and C for each sloping surface are obtained from the PANS-OPS OAS software with the constraint that the Category II flight director constants shall be used for MLS Category II autocoupled operations. The PANS-OPS OAS software gives coefficients for glidepath angles between 2.5° and 3.5° in 0.1° steps, and for any azimuth-threshold distance between 2 000 m and 4 500 m. Extrapolation outside these limits is not permitted. If an azimuth-threshold distance outside this range is entered, the PANS-OPS OAS software gives the coefficients for 2 000 m or 4 500 m as appropriate, which must be used. For an example of the PANS-OPS OAS software results, see Figure II-1-3-15.

3.4.8.5 Calculation of OAS heights

To calculate the height z of any of the sloping surfaces at a location x' , y' , the appropriate constants should be first obtained from the PANS-OPS OAS software. These values are then substituted in the equation $z = Ax' + By' + C$. If it is not clear which of the OAS surfaces is above the obstacle location, this should be repeated for the other sloping surfaces. The OAS height is the highest of the plane heights (zero if all the plane heights are negative).

Note.— The PANS-OPS OAS software also contains an OCH calculator that will show the height of the OAS surface z above any x , y location. It includes all the adjustments specified for MLS geometry, aircraft dimensions, missed approach climb gradient and MLS approach reference datum height.

3.4.8.6 OAS template construction

Templates, or plan views of the OAS contours to map scale, are sometimes used to help identify obstacles for detail survey (see Figure II-1-3-14). The OAS data in the PANS-OPS software includes the coordinates of the points of intersection:

- a) of the sloping surfaces at threshold level. The intersection coordinates are labeled as C, D and E (Figure II-1-3-14);
- b) at 300 m above threshold level for Cat I; and
- c) at 150 m for Cat II.

3.4.8.7 Adjustment of OAS constants

3.4.8.7.1 *General.* The following paragraphs describe the adjustments that the PANS-OPS OAS software makes to the OAS constants. These adjustments are mandatory when the standard conditions are not met (see 3.1.3, “Standard conditions”). Optional adjustments may be made when so specified. For examples of calculations see the *Instrument Flight Procedures Construction Manual* (Doc 9368).

3.4.8.7.2 *Reasons for adjusting constants.* The constants may be modified to account for the following:

- a) dimensions of specific aircraft (see 3.4.8.7.3, below);
- b) the height of the MLS approach reference datum above the nominal value (see 3.4.8.7.4, below);
- c) Category I azimuths having a sector width greater than 210 m at threshold (see 3.4.8.7.5, below);
- d) use of flight director (manually flown) in Cat II (see 3.4.8.7.6, below); and
- e) missed approach climb gradient (see 3.4.8.7.7, below).

3.4.8.7.3 *Specific aircraft dimensions.* An adjustment is mandatory where aircraft dimensions exceed those specified in 3.1.3, “Standard Conditions” and is optional for aircraft with smaller dimensions. The PANS-OPS OAS software adjust the OAS coefficients and template coordinates for the standard dimensions of Category A, B, C, D and D_L aircraft automatically. It will do the same for specific aircraft dimensions in any category. It uses the following correction formula to adjust the coefficient C for the W, X and Y surfaces:

$$\text{W surface: } C_{w\text{corr}} = C_w - (t - 6)$$

$$\text{X surface: } C_{x\text{corr}} = C_x - B_x \cdot P$$

$$\text{Y surface: } C_{y\text{corr}} = C_y - B_y \cdot P$$

where:

$$P = \left[\frac{t}{B_x} \text{ or } S + \frac{t - 3}{B_x}, \text{ whichever is the maximum} \right] - \left[\frac{6}{B_x} \text{ or } 30 + \frac{3}{B_x}, \text{ whichever is the maximum} \right]$$

and: s = semi-span

t = vertical distance between paths of the GP antenna and the lowest part of the wheels.

3.4.8.7.4 *Height of the MLS approach reference datum.* The constants are based on an MLS approach reference datum height (RDH) of 15 m. An adjustment to the OAS constants is mandatory for an RDH less than 15 m, and is optional for an RDH greater than 15 m. The PANS-OPS OAS software adjusts the OAS coefficients and template coordinates by correcting the tabulated values of the coefficient C for the W, X and Y surfaces as follows:

$$C_{\text{corr}} = C + (\text{RDH} - 15)$$

where: C_{corr} = corrected value of coefficient C for the appropriate surface

C = tabulated value.

3.4.8.7.5 *Modification for Cat I azimuths with nominal course width greater than 210 m at threshold.* Where the MLS azimuth sector width at threshold is greater than the nominal value of 210 m, the ILS collision risk model (CRM) method described in 3.4.9 shall be used. Adjustments for sector widths less than 210 m shall not be made and are inhibited in the PANS-OPS OAS software.

3.4.8.7.6 *Use of flight director (manually flown) in Cat II.* The Cat I OAS shall be used.

3.4.8.7.7 *Missed approach gradient.* If equipment is capable of missed approach climb gradients better than the nominal 2.5 per cent, the Y and Z surfaces may be adjusted. This adjustment is achieved by selecting the desired missed approach climb gradient in the PANS-OPS OAS software. The programme then adjusts the Y and Z surface coefficients.

3.4.8.8 *Determination of OCA/H with OAS or basic ILS surfaces*

3.4.8.8.1 *General.* The OCA/H is determined by accounting for all obstacles which penetrate the basic ILS surfaces defined in 3.4.7.2 and the OAS surfaces applicable to the ILS category of operation being considered. The exemptions listed in 3.4.7.3, “Determination of OCA/H with basic ILS surfaces” for obstacles penetrating the basic ILS surfaces may be applied to obstacles penetrating the OAS, providing the criteria listed in that paragraph are met. The surfaces which apply to each MLS category of operations are:

- a) *MLS Cat I*: ILS Cat I OAS;
- b) *MLS Cat II flight director*: ILS Cat I OAS;
- c) *MLS Cat II autocoupled*: ILS Cat II OAS, using flight director and those portions of ILS Cat I which lie above the limits of ILS Cat II; and
- d) *MLS Cat III autocoupled*: Same as MLS Cat II autocoupled.

3.4.8.8.2 *Calculation of OCA/H values with OAS*. Accountable obstacles, as determined below in 3.4.8.8.2.1, “OCA/H calculation steps” are divided into approach and missed approach obstacles. The standard method of categorization is as follows: Approach obstacles are those between the FAP and 900 m after threshold. Missed approach obstacles are those in the remainder of the precision segment (see Figure II-1-3-16). However, in some cases this categorization of obstacles may produce an excessive penalty for certain missed approach obstacles (see Attachment to Part II, 1.9). Where desired by the appropriate authority, missed approach obstacles may be defined as those above a plane surface parallel to the plane of the glide path (elevation angle) and with origin at -900 m (see Figure II-1-3-17), i.e. obstacle height greater than $[(900 + x) \tan \theta]$.

3.4.8.8.2.1 *OCA/H calculation steps*

- a) Determine the height of the highest approach obstacle.
- b) Convert the heights of all missed approach obstacles (h_{ma}) to the heights of equivalent approach obstacles (h_a) by the formula given below, and determine the highest equivalent approach obstacle.
- c) Determine which of the obstacles identified in steps a) and b) is the highest. This is the controlling obstacle.
- d) Add the appropriate aircraft category related margin (Table II-1-3-2) to the height of the controlling obstacle.

$$h_a = \frac{h_{ma} \cot Z + (x_z + x)}{\cot Z + \cot \theta}$$

- where:
- h_a = height of equivalent approach obstacle
 - h_{ma} = height of missed approach obstacle
 - θ = angle of glide path (elevation angle)
 - Z = angle of missed approach surface
 - x = range of obstacle relative to threshold (negative after threshold)
 - x_z = distance from threshold to origin of Z surface (900 m (700 m Cat H))

3.4.8.8.3 *Adjustment for high airfield elevations and steep glide path angles*

3.4.8.8.3.1 *Height loss (HL)/altimeter margins*. The margins in Table II-1-3-2 shall be adjusted as follows:

- a) for airfield elevation higher than 900 m (2 953 ft), the tabulated allowances shall be increased by 2 per cent of the radio altimeter margin per 300 m (984 ft) airfield elevation; and

- b) for glide path (elevation angles) greater than 3.2° in exceptional cases, the allowances shall be increased by 5 per cent of the radio altimeter margin per 0.1° increase in glide path (elevation angle) between 3.2° and 3.5°.

3.4.8.8.3.1.1 Procedures involving glide paths greater than 3.5° or any angle when the nominal rate of descent (V_{at} for the aircraft type \times the sine of the glide path angle) exceeds 5 m/sec (1 000 ft/min), are non-standard. They require the following:

- a) increase of height loss margin (which may be aircraft type specific);
- b) adjustment of the origin of the missed approach surface;
- c) adjustment of the slope of the W surface;
- d) re-survey of obstacles; and
- e) the application of related operational constraints.

Such procedures are normally restricted to specifically approved operators and aircraft, and are associated with appropriate aircraft and crew restrictions. They are not to be used as a means to introduce noise abatement procedures.

3.4.8.8.3.1.2 Appendix B to Chapter 1 shows the procedure design changes required and the related operational/certification considerations.

Example: Aircraft Category C — Aerodrome elevation: 1 650 m above MSL; glide path angle 3.5°.

Tabulated allowances: radio altimeter 22 m

(Table II-1-3-2) pressure altimeter 46 m

Correction for aerodrome elevation:

$$22 \times \frac{2}{100} \times \frac{1\,650}{300} = 2.42 \text{ m}$$

Correction for glide path angle:

$$22 \times \frac{5}{100} \times \frac{3.5 - 3.2}{0.1} = 3.30 \text{ m}$$

Total correction 5.72 m rounded up to 6 m.

Corrected radio altimeter margin $22 + 6 = 28$ m.

Corrected pressure altimeter margin $46 + 6 = 52$ m.

3.4.8.8.3.2 *Exceptions and adjustments to values in Table II-1-3-2.* Values in Table II-1-3-2 are calculated to account for an aircraft using normal manual overshoot procedures from OCA/H on the nominal approach path. The values in Table II-1-3-2 do not apply to Cat III operations. The values do not consider the lateral displacement of an obstacle nor the probability of an aircraft being so displaced. If consideration of these joint probabilities is required, then the ILS CRM discussed in 3.4.9 shall be used. Values in Table II-1-3-2 may be adjusted for specific aircraft types where adequate flight and theoretical evidence is available, i.e. the height loss value corresponding to a probability of 1×10^{-5} (based on a missed approach rate of 10^{-2}).

3.4.8.8.3.3 *Radio altimeter verification.* If the radio altimeter OCA/H is promulgated, operational checks shall have confirmed the repeatability of radio altimeter information.

3.4.8.8.3.4 *Height loss (HL)/altimeter margins for a specific speed at threshold.* If a height loss/altimeter margin is required for a specific V_{at} , the following formulae apply (see also Table II-1-3-4):

Use of radio altimeter:

Margin = $(0.096 V_{at} - 3.2)$ metres where V_{at} in km/h

Margin = $(0.177 V_{at} - 3.2)$ metres where V_{at} in kt

Use of pressure altimeter:

Margin = $(0.068 V_{at} + 28.3)$ metres where V_{at} in km/h

Margin = $(0.125 V_{at} + 28.3)$ metres where V_{at} in kt

where V_{at} is the speed at threshold based on 1.3 times stall speed in the landing configuration at maximum certificated landing mass.

Note.— The equations assume the aerodynamic and dynamic characteristics of the aircraft are directly related to the speed category. Thus, the calculated height loss/altimeter margins may not realistically represent small aircraft with V_{at} at maximum landing mass exceeding 165 kt.

3.4.8.9 *Effect of obstacle density on OCA/H.* To assess the acceptability of obstacle density below the OAS, the ILS CRM described in 3.4.9 may be used. This can provide assistance by comparing aerodrome environments and by assessing risk levels associated with given OCA/H values. It is emphasized that it is not a substitute for operational judgement.

3.4.9 Obstacle clearance in the precision segment — application of the ILS collision risk model (CRM) to MLS operations

3.4.9.1 *General.* The ILS CRM is a computer program that establishes the numerical risk which can be compared to the target level of safety for aircraft operating to a specified OCA/H height. A description of the programme and instructions on its use, including the precise format of both the data required as input and the output results, are given in the *Manual on the Use of the Collision Risk Model (CRM) for ILS Operations* (Doc 9274).

3.4.9.2 *Input.* When applied to MLS operations, the ILS CRM requires the following data as input:

- a) *aerodrome details:* name, runway threshold position and runway orientation in map grid coordinates (optional), threshold elevation above MSL;
- b) *MLS parameters:* category (the appropriate ILS category as defined in 3.4.8.8.1), glide path (elevation angle), azimuth-threshold distance, azimuth nominal course width, height of MLS reference datum above threshold;
- c) *missed approach parameters:* decision height (obstacle clearance height) and missed approach turn point;
- d) *aircraft parameters:* type, wheel height (antenna to bottom of wheel), and wing semi-span, aircraft category (A, B, C, D or D_L) missed approach climb gradient; and

Note.— The CRM does not consider Category E aircraft.

- e) *obstacle data*: obstacle boundaries (either as x and y coordinates relative to the runway threshold or as map grid coordinates) and obstacle height (either above threshold elevation or above MSL). For density assessment, all obstacles penetrating the basic ILS surfaces described in 3.4.7.2 must be included.

3.4.9.3 *Output and application*. The output of the programme is:

- a) the overall (total) risk of collision with obstacles for aircraft operating to a specified OCA/H; and
 b) the minimum OCA/H which will provide the target level of safety.

These options are detailed in Doc 9274, *Manual on the Use of the Collision Risk Model (CRM) for ILS Operations*. The user, by rerunning the ILS CRM with the appropriate parameters, can assess the effect on the safety of operations of any alteration in the parameters, typically varying the glide path, elevation angle or remaining obstacles.

3.5 MISSED APPROACH SEGMENT

3.5.1 General

3.5.1.1 The criteria for the final missed approach are based on those for the general criteria (see Part I, Section 4, Chapter 6). Certain modifications have been made to allow for the different areas and surfaces associated with the MLS precision segment and for the possible variation in OCA/H for that segment with aircraft category. Area construction is according to the navigation system specified for the missed approach.

3.5.1.2 The datum used for calculation of distances and gradients in obstacle clearance calculations is termed “start of climb” (SOC). It is defined by the height and range at which the plane GP’ — a plane parallel with the glide path (elevation angle) and with origin at –900 m at threshold level — reaches an altitude OCA/H – HL (OCA/H and HL must both relate to the same category of aircraft).

3.5.1.3 Where obstacles identified in the final missed approach segment result in an increase in any of the OCA/H calculated for the precision segment, a higher gradient of the missed approach surface (Z) may be specified in addition if this will provide clearance over those obstacles at a specified lower OCA/H (see Part I, Section 4, Chapter 6, 6.2.2.1, “Climb gradient in the intermediate phase”).

3.5.1.4 Missed approach segment using RNAV or RNP systems for track guidance can be utilized. Only the systems capable of navigation accuracy of 1 NM or better in this phase of flight can be considered. Refer to Part III, Section 1, Chapter 1, Table III-1-1-1 for the navigation specifications that can be used for missed approach.

3.5.2 Straight missed approach

3.5.2.1 *General*. The precision segment terminates at the point where the Z surface reaches a height 300 m above threshold. The width of the Z surface at that distance defines the initial width of the final missed approach area which splays at an angle of 15 degrees from that point, as shown in Figure II-1-3-18. There are no secondary areas.

3.5.2.2 *Straight missed approach obstacle clearance*. (See Figure II-1-3-19.) Obstacle elevation/height in this final missed approach area shall be less than

$$(OCA/H_{ps} - HL) + d_o \tan Z$$

where:

- a) OCA/H of the precision segment (OCA/H_{ps}) and HL (Table II-1-3-2 value) both relate to the same aircraft category;
- b) d_o is measured from SOC parallel to the straight missed approach track; and
- c) Z is the angle of the missed approach surface with the horizontal plane.

If this requirement cannot be met, a turn shall be prescribed to avoid the obstacle in question. If a turn is not practical, the OCA/H shall be raised.

3.5.2.3 Transition from conventional navigation to an RNAV or RNP missed approach may be defined by an RNAV or RNP fix located on the extended azimuth course, or by a turn at an altitude direct to a waypoint (see Figure II-1-3-24). If the RNAV or RNP track is collinear with the azimuth course, the area abeam the SOC shall be expanded at a 15 degree angle from the track course until it reaches the applicable width of the RNAV or RNP area constructed on the extended azimuth course. In the region between the lateral boundaries of the Z surface and the outer boundaries of the area, the obstacle evaluation shall be based on the Y surface and a mathematical extrapolation of the Y surface where the area is outside the lateral boundaries of the OAS 300 m contour. The Z surface shall continue to splay at the same angle until reaching the width of the RNAV or RNP area. Secondary areas shall apply from the point where the width of the Z surface reaches the width of the RNAV or RNP primary area (see Figure II-1-3-22). Obstacle clearance up to this point for the extended Y and Z surfaces shall be the same as in the precision segment (see 1.4.8 “Obstacle clearance of the precision segment using obstacle assessment surface (OAS) criteria”), and this shall also apply further out to all portions of the Z surface that are within the RNAV or RNP primary area. The principle of secondary areas shall apply between the edge of the RNAV or RNP primary area and the edge of the total area. If an obstacle penetrates either the extended Y or the Z surface within the secondary area, its elevation/height shall be less than:

$$(OCA/H_{ps} - HL) + d_o \tan Z + M$$

where:

- a) OCA/H of the precision segment (OCA/H_{ps}) and HL (Table II-1-3-2 value) both relate to the same aircraft category;
- b) d_o is measured from SOC parallel to the straight missed approach track;
- c) Z is the angle of the missed approach surface with the horizontal plane; and
- d) M is zero at the edge of the primary area increasing linearly to 30 m (98 ft) at the edge of the total area.

3.5.3 Turning missed approach

3.5.3.1 *General.* Turns may be prescribed at a designated turning point (TP), at a designated altitude/height, or “as soon as practicable”. The criteria used depend on the location of the turn relative to the normal termination of the precision segment (see 3.4.6, “Termination”) and are as follows:

- a) *turn after normal termination of the precision segment.* If a turn is prescribed after normal termination of the precision segment, the general criteria of Part I, Section 4, Chapter 6, 6.4.5, “Turn initiated at a designated altitude/height” and Part I, Section 4, Chapter 6, 6.4.6, “Turn initiated at a designated turning point (TP)” apply with the following exceptions:

- 1) OCA/H is replaced by (OCA/H – HL) as in 3.5.2.2, “Straight missed approach obstacle clearance”; and
 - 2) because SOC is related to OCA/H, it is not possible to obtain obstacle clearance by the means used in non-precision approaches (that is, by independent adjustment of OCA/H or MAPt);
- b) *turn before normal termination of the precision segment.* If a turn is prescribed at a designated altitude/height which is less than 300 m above threshold, or at a designated TP such that the earliest TP is within the normal termination range, the criteria specified in 3.5.3.2 and 3.5.3.3 below shall be applied:
 - c) for missed approaches using RNAV or RNP, fly-by or flyover turns should be limited to 90 degrees. RF turns are not permitted as the first RNP leg of the missed approach since there would be no tangent RNP entry track specified. In this case, a TF leg with the first waypoint located on the extended azimuth course is required, preceding the RF leg;
 - d) the earliest location of the first RNAV or RNP fix is at a distance of ATT after the SOC (see Figure II-1-3-25). If the fix designates a fly-by turn, the additional distance $d_1 + 3V/3 600$ where V is the TAS must be added prior to the fix ($d_1 = r \tan A/2$); and
 - e) for an RNAV or RNP missed approach, standard turn construction and turning MOC (50 m (164 ft) for turns of more than 15 degrees and 30 m (98 ft) for all other turns) shall apply after the earliest turning point. Secondary areas shall apply between the standard width of the RNAV or RNP primary area and the edge of the total area, except that obstacles located under the Y surface on the outer side of the turn need not be considered. See Figures II-1-3-22 and II-1-3-23.

Note.— Adjustments to designated TP location or to the designated turn altitude may involve redrawing the associated areas and recalculating the clearances. This can exclude some obstacles or introduce new ones. Thus, when it is necessary to obtain the minimum value of OCA/H – particularly when constraints due to obstacles are very high – it may be necessary to adjust the designated TP or turn altitude by trial and error. (See Section 1, Appendix A to Chapter 1).

3.5.3.2 Turn at a designated altitude/height less than 300 m above threshold

3.5.3.2.1 The general criteria apply (see Part I, Section 4, Chapter 6, 6.4.5, “Turn initiated at a designated altitude/height”) as amplified and modified by the contents of this section. Construction of the turn initiation area and the subsequent turn are illustrated in Figure II-1-3-20.

3.5.3.2.2 *Turn altitude/height.* The general criteria apply, modified as follows. The precision segment terminates (and the final missed approach segment begins) at the TP. This allows the calculation of OCA/H_{ps} and (OCA/H_{ps} – HL). SOC is then determined, and turn altitude/height (TNA/H) is computed from the following relationship:

$$TNA/H = OCA/H_{ps} - HL + d_z \tan Z$$

where: d_z is the horizontal distance from SOC to the TP; and

OCA/H_{ps} = OCA/H calculated for the precision segment.

If the TP is located at the SOC, the chart shall be annotated “turn as soon as practicable to ... (heading or facility)” and shall include sufficient information to identify the position and height of the obstacles dictating the turn requirement.

3.5.3.2.3 Areas

3.5.3.2.3.1 *Turn initiation area* (See Figure II-1-3-20). The turn initiation area is bounded by the 300 m Category I Y surface contour, and terminates at the TP.

Note.— The earliest TP is considered to be at the beginning of the 300 m Category I Y surface contour (point D) unless a fix is specified to limit early turns (see 3.5.3.2.4.2), “Safeguarding of early turns”).

3.5.3.2.3.2 *Turn boundary construction.* Turn boundaries are constructed as specified in Part I, Section 2, Chapter 3, “Turn area construction”

3.5.3.2.4 Obstacle clearance

a) *Obstacle clearance in the turn initiation area.* Obstacle elevation/height in the turn initiation area shall be less than:

- 1) turn altitude/height – 50 m (164 ft) for turns more than 15°; and
- 2) turn altitude/height – 30 m (98 ft) for turns 15° or less,

except that obstacles located under the Y surface on the outer side of the turn need not be considered when calculating turn altitude/height.

b) *Obstacle clearance in the turn area.* Obstacle elevation/height in the turn area and subsequently shall be less than:

$$\text{turn altitude/height} + d_o \tan Z - \text{MOC}$$

where d_o is measured from the obstacle to the nearest point on the turn initiation area boundary and MOC is:

- 1) 50 m (164 ft) for turns more than 15°; and
- 2) 30 m (98 ft) for turns 15° or less,

reducing linearly to zero at the outer edge of the secondary areas, if any.

3.5.3.2.4.1 *Turn altitude/height adjustments.* If the criteria specified in 3.5.3.2.4, “Obstacle clearance”, above cannot be met, the turn altitude/height shall be adjusted. This can be done in two ways:

- a) *adjust turn altitude/height without changing OCA/H:* this means that the TP will be moved and the areas redrawn accordingly; and
- b) *raise turn altitude/height by increasing OCA/H:* this results in a higher turn altitude over the same TP. The turn areas remain unchanged.

3.5.3.2.4.2 *Safeguarding of early turns.* Where the published procedure does not specify a fix to limit turns for aircraft executing a missed approach from above the designated turn altitude/height, an additional check of obstacles shall be made. The general criteria of Part I, Section 4, Chapter 6, 6.4.5.6, “Safeguarding of early turns” and general principles of Part I, Section 4, Chapter 6, Figure I-4-6-14 apply with the following modifications:

- a) the limit of the final approach area is replaced by the line DD” of the OAS surfaces and its extension;
- b) the FAF is replaced by the FAP;

- c) the earliest MAPt is replaced by the line D"D" (earliest limit of the turn initiation area); and
- d) if the criterion cannot be met, then the procedure must prohibit turns before a point equivalent to the MAPt and a note must be added on the profile view of the approach chart.

3.5.3.3 Turn at a designated TP with earliest TP before normal termination of precision segment

3.5.3.3.1 Where a turn is specified at a designated TP, and the earliest TP is before the normal termination range of the precision segment, the precision segment terminates at the earliest TP. This allows the calculation of OCA/H_{ps} and $(OCA/H_{ps} - HL)$; SOC is then determined.

3.5.3.3.2 *Turn area.* The turn area is constructed as specified in Part I, Section 4, Chapter 6, 6.4.6.3, "Construction of the turn area" except that it is based on the width of the 300 m OAS Y surface contours at the earliest and latest TP (see Figure II-1-3-21).

3.5.3.3.3 *Obstacle clearance.* Obstacle elevation/height shall be less than:

$$(OCA/H_{ps} - HL) + d_o \tan Z - MOC$$

where:

d_o = d_z + shortest distance from obstacle to line K-K,

d_z = horizontal distance from SOC to the earliest TP,

and MOC is:

50 m (164 ft) for turns more than 15° and

30 m (98 ft) for turns 15° or less.

If the obstacle elevation/height exceeds this value, the OCA/H must be increased, or the TP moved to obtain the required clearance (see Appendix A to Chapter 1).

3.6 SIMULTANEOUS PRECISION APPROACHES TO PARALLEL OR NEAR-PARALLEL INSTRUMENT RUNWAYS

Note.— Guidance material is contained in the Manual on Simultaneous Operations on Parallel or Near-Parallel Instrument Runways (Doc 9643).

3.6.1 General

When it is intended to use precision approach procedures to parallel runways simultaneously, the following additional criteria shall be applied in the design of both procedures:

- a) the maximum intercept angle with the final approach course is 30°. The point of intercepting final approach course should be located at least 3.7 km (2.0 NM) prior to the point of intercepting the glide path;

- b) the minimum altitudes of the intermediate approach segments of the two procedures differ by at least 300 m (1 000 ft); and
- c) the nominal tracks of the two missed approach procedures diverge by at least 30°. Associated missed approach turns shall be specified as “as soon as practicable”.

3.6.2 Obstacle clearance

The obstacle clearance criteria for precision approaches, as specified in the designated chapters apply for each of the parallel precision procedures. In addition to these criteria, a check of obstacles shall be made in the area on the far side of the parallel runway in order to safeguard early turns required to avoid potential intruding aircraft from the adjacent runway. This check can be made using a set of separately defined parallel approach obstacle assessment surfaces (PAOAS). An example of a method to assess obstacles for these procedures is included in Appendix D to Chapter 1.

3.7 PROMULGATION

3.7.1 General

3.7.1.1 The general criteria in Part I, Section 2, Chapter 1, 1.12, “Promulgation” apply as amplified by criteria in Part III, Section 5, Chapter 1, 1.3.4 for chart notes. The instrument approach chart for an MLS approach procedure shall be identified by the title MLS Rwy XX. If CAT II and/or III minima are included on the chart, the title shall read MLS Rwy XX CAT II or MLS Rwy XX CAT II & III, as appropriate. If more than one MLS procedure is published for the same runway, the Duplicate Procedure Title convention shall be applied. An example where the convention is applied is two MLS procedures with different segments, such as different missed approach segments.

3.7.1.2 When a final approach fix is identified at the FAP, a warning shall be appended to the procedure stating that descent on the glidepath below the FAF altitude is not permitted until passing the FAF.

3.7.2 Promulgation of OCA/H values

3.7.2.1 *Promulgation of OCA/H for MLS Cat I and II approach procedures*

3.7.2.1.1 The OCA or OCH values, as appropriate, shall be promulgated for those categories of aircraft for which the procedure is designed. The values shall be based on the following standard conditions:

- a) Cat I flown with pressure altimeter;
- b) Cat II flown autocoupled with radio altimeter;
- c) Cat II flown with radio altimeter and flight director;
- d) standard aircraft dimensions (see 3.1.3, “Standard conditions”); and
- e) 2.5 per cent missed approach climb gradient.

3.7.2.1.2 Additional values of OCA/H may be agreed upon between operators and the appropriate authority and promulgated, on the basis of evidence supporting the modifications defined in 3.4.8.7, “Adjustment of OAS constants”.

3.7.2.1.3 Use of OCA/H values for MLS Category I approach procedures based on radio altimeter height loss margins may be agreed upon between operators and the appropriate authority, and the values promulgated, if the requirement of 3.4.8.8.3.3, “Radio altimeter verification” is met.

3.7.2.2 *Promulgation of MLS Category III approach procedures*

Category III operations may be permitted subject to the appropriate Category II OCA/H being below the height of the Annex 14 inner horizontal surface. Category III operations may also be permitted with a Category II OCA/H between the height of the inner horizontal surface and 60 m provided the Annex 14 Category II inner approach, inner transitional and balked landing surfaces are extended to protect that OCA/H (see Figure II-1-3-9 a)).

3.7.3 Degrees magnetic

The final approach track for the MLS procedure is always specified and promulgated in degrees magnetic.

3.7.4 Turn at a designated altitude/height (missed approach)

If the TP is located at the SOC, the chart shall be annotated “turn as soon as practicable to ... (heading or facility)” and shall include sufficient information to identify the position and height of the obstacles dictating the turn requirement.

3.7.5 Turn at a designated TP (missed approach)

Where the procedure requires that a turn be executed at a designated TP, the following information must be published with the procedure:

- a) the TP, when it is designated by a fix; or
- b) the intersecting VOR radial, NDB bearing, or DME distance where there is no track guidance (see Part I, Section 2, Chapter 2, 2.6.5, “Missed approach fixes”).

3.7.6 Procedures involving non-standard glide path angles

Procedures involving glide paths greater than 3.5° or any angle when the nominal rate of descent exceeds 5 m/sec (1 000 ft/min), are non-standard and subject to restrictions (see 3.4.8.8.3.1, “Height loss (HL)/altimeter margins”). They are normally restricted to specifically approved operators and aircraft, and are promulgated with appropriate aircraft and crew restrictions annotated on the approach chart.

3.7.7 Additional gradient for the final missed approach segment

If obstacles identified in the final missed approach segment result in an increase in any of the OCA/H calculated for the precision segment, an additional steeper gradient may also be specified for the gradient of the missed approach surface (Z) for the purposes of lowering the OCA/H (see Part I, Section 4, Chapter 6, 6.2.3.1, “Climb gradient in the final phase”).

Table II-1-3-1. Minimum length of intermediate segment

<i>Intercept angle with the final Approach track (degree)</i>	<i>Minimum distance between the interception of the final approach track and the interception of the glide path</i>	
	<i>Cat A/B</i>	<i>Cat C/D/E</i>
0 – 15	2.8 km (1.5 NM)	2.8 km (1.5 NM)
16 – 30	3.7 km (2.0 NM)	3.7 km (2.0 NM)
31 – 60	3.7 km (2.0 NM)	4.6 km (2.5 NM)
61 – 90 or within a racetrack or reversal procedure	3.7 km (2.0 NM)	5.6 km (3.0 NM)

Table II-1-3-2. Height loss/altimeter margin

<i>Aircraft category (Vat)</i>	<i>Margin using radio altimeter</i>		<i>Margin using pressure altimeter</i>	
	<i>Metres</i>	<i>Feet</i>	<i>Metres</i>	<i>Feet</i>
A — 169 km/h (90 kt)	13	42	40	130
B — 223 km/h (120 kt)	18	59	43	142
C — 260 km/h (140 kt)	22	71	46	150
D — 306 km/h (165 kt)	26	85	49	161

Table II-1-3-3. Objects which may be ignored in OCA/H calculations

	<i>Maximum height above threshold</i>	<i>Minimum lateral distance from runway centre line</i>
EL antenna	17 m (55 ft)	120 m
Aircraft taxiing	22 m (72 ft)	150 m
A/C in holding bay or in taxi holding position at a range between threshold and -250 m	22 m (72 ft)	120 m
A/C in holding bay or in taxi holding position at a range between threshold and -250 m (Cat I only)	15 m	75 m

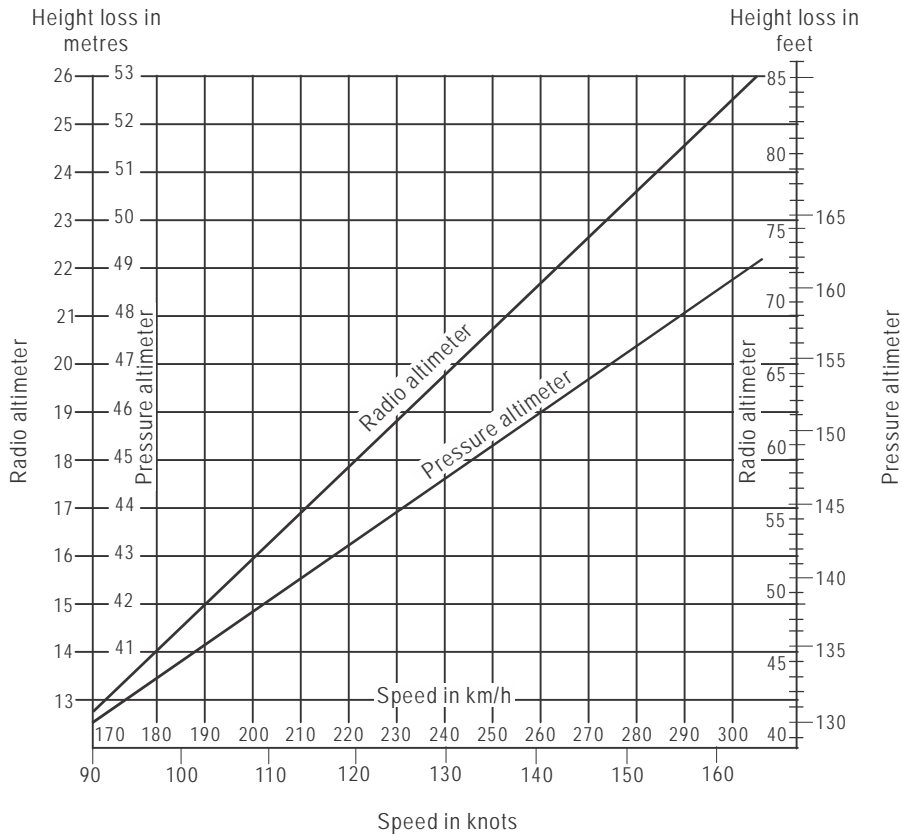

Table II-1-3-4. Height loss altimeter setting vs. speed

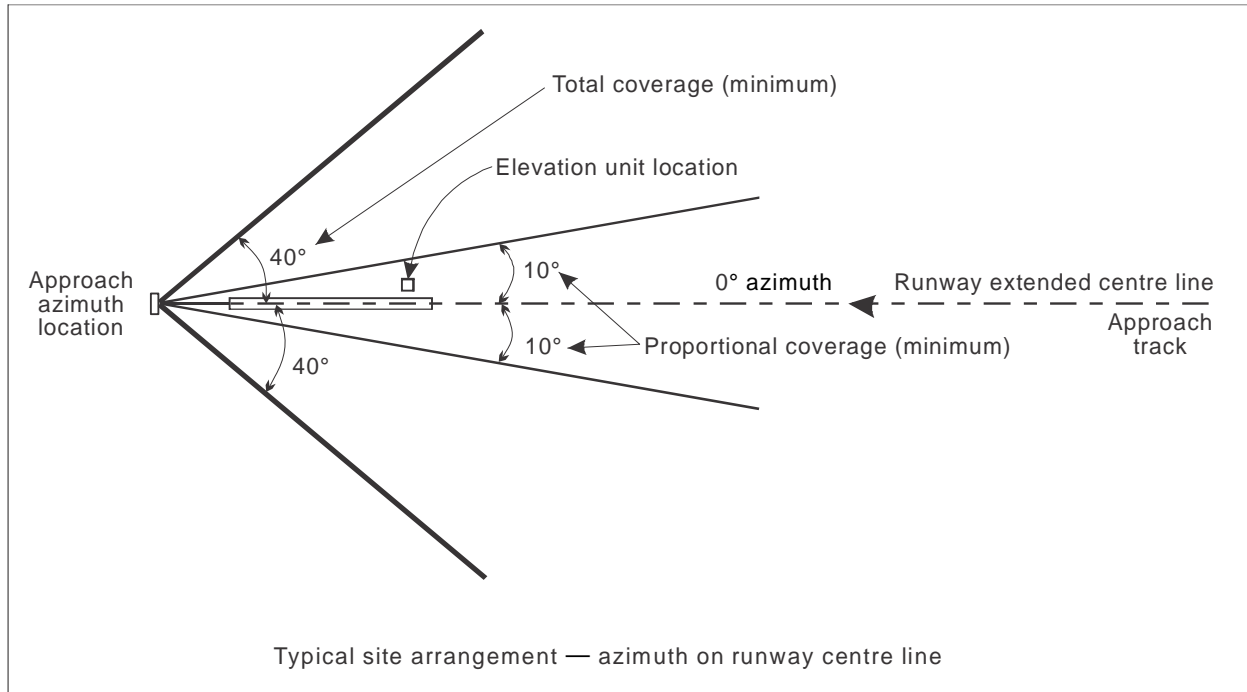

Figure II-1-3-1. Site arrangements suitable for MLS criteria application

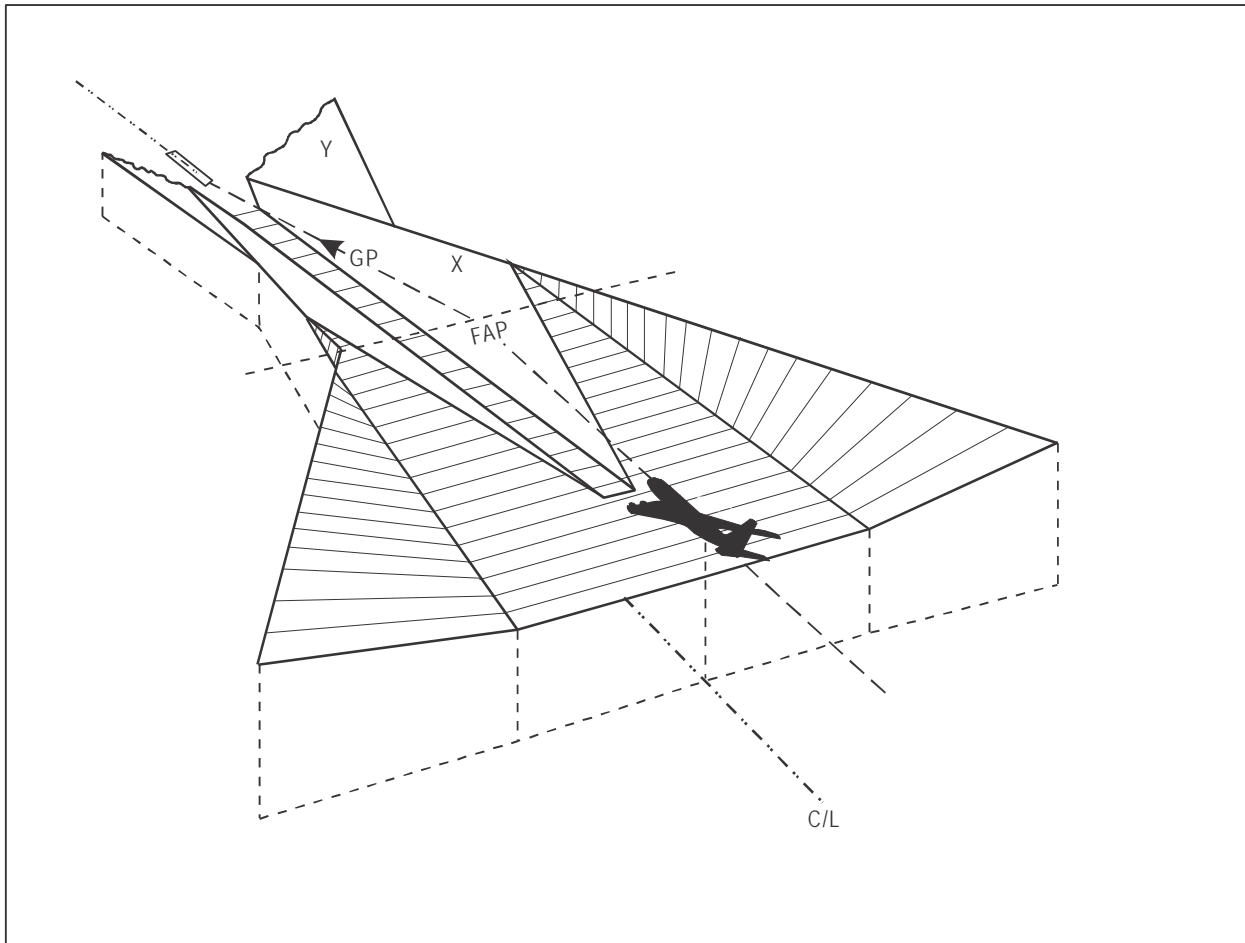

Figure II-1-3-2. Interface — final approach/preceding segment perspective view

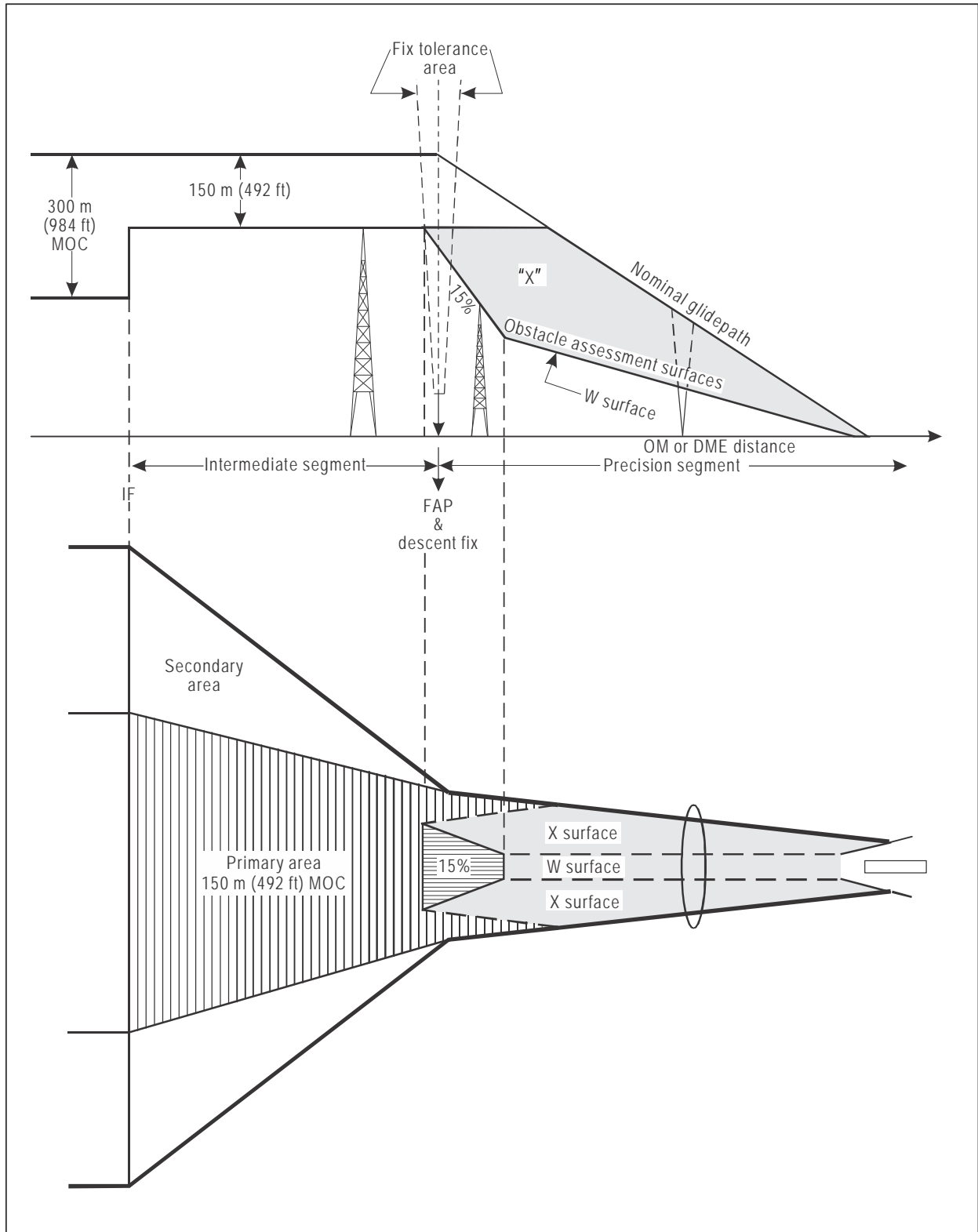

Figure II-1-3-3. Final approach fix defined by descent fix located at final approach point

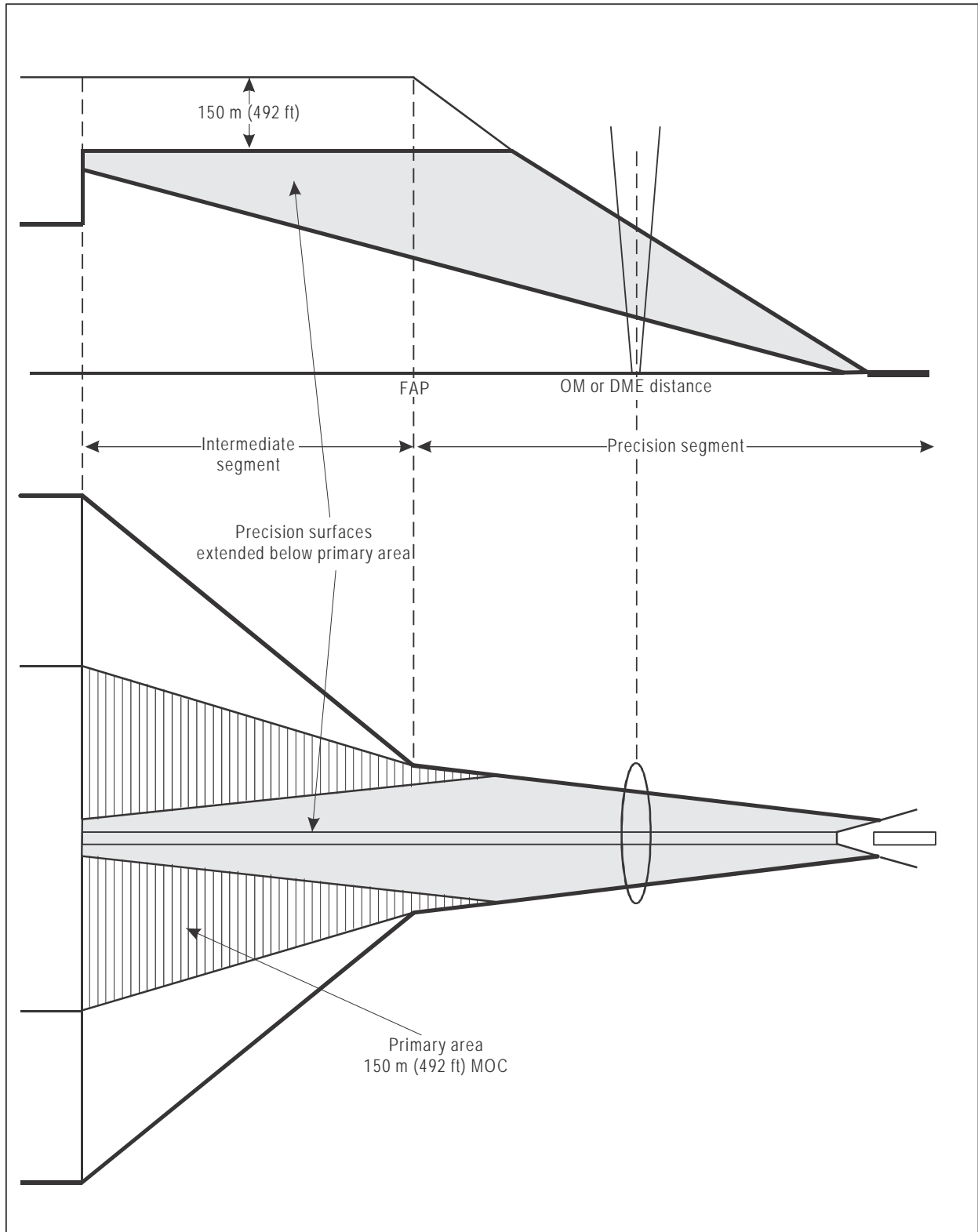

Figure II-1-3-4. Precision segment with no final approach fix

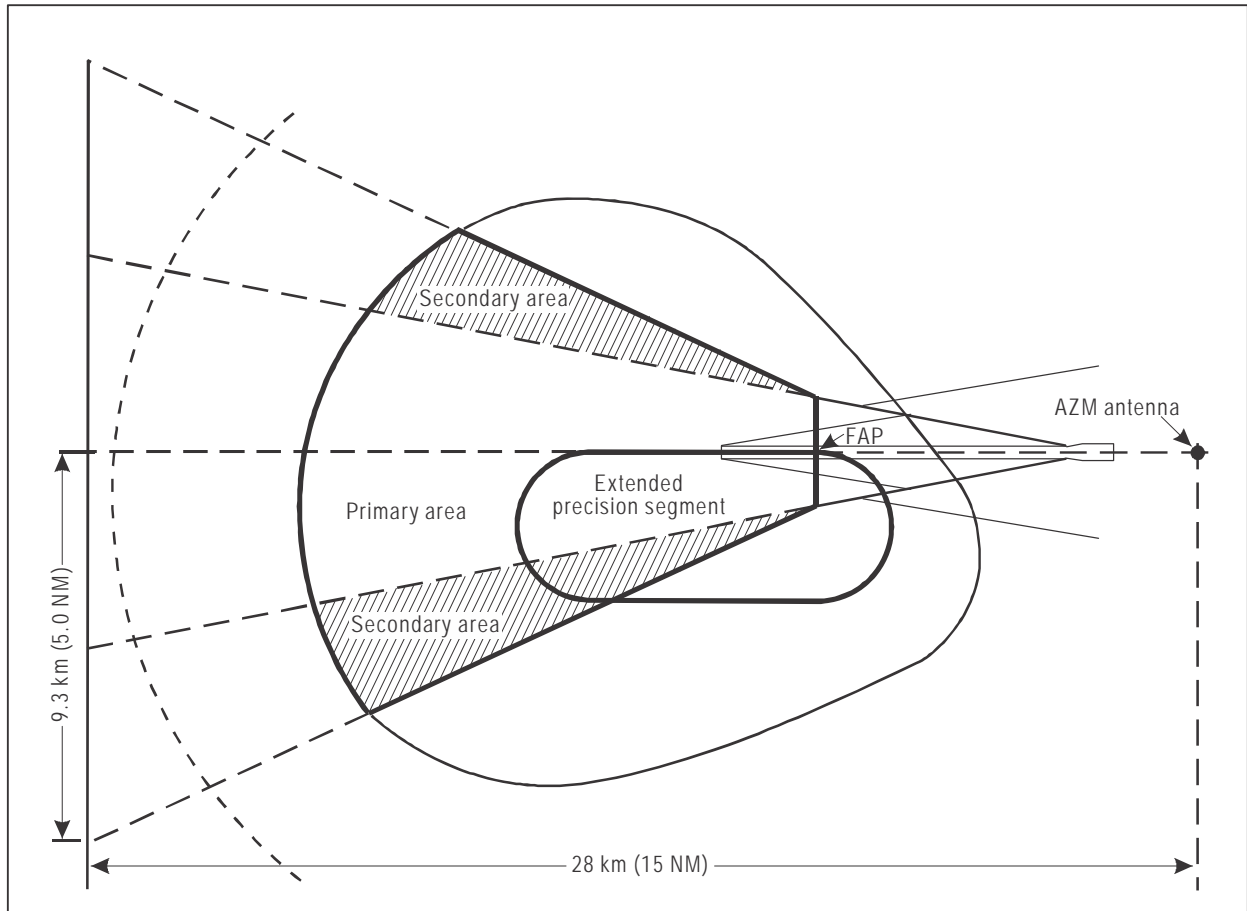

Figure II-1-3-5. Intermediate approach area. MLS approach using reversal or racetrack procedure

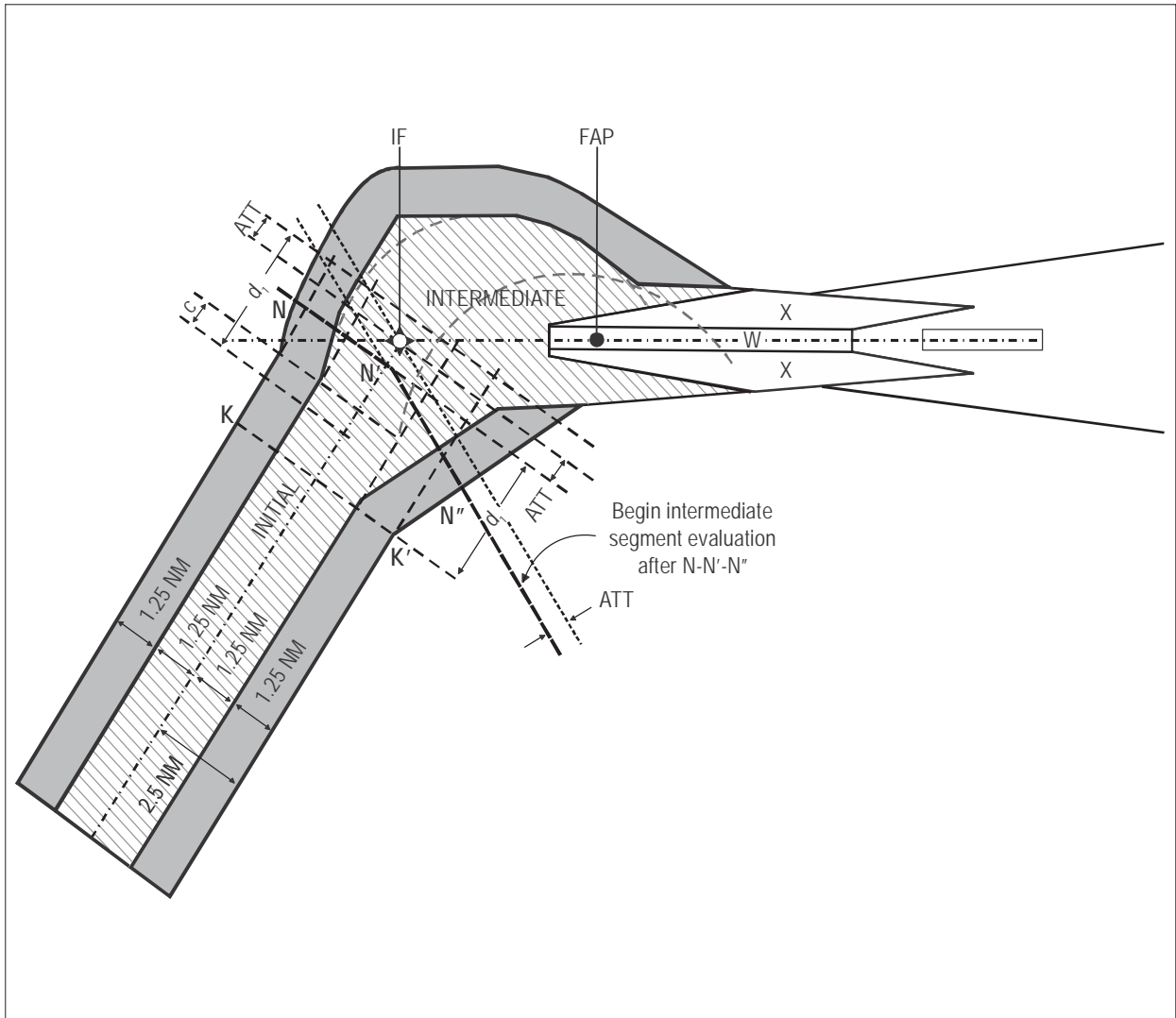

Figure II-1-3-6. Example: RNAV 1 or RNP 1 to MLS transition, 60° intercept

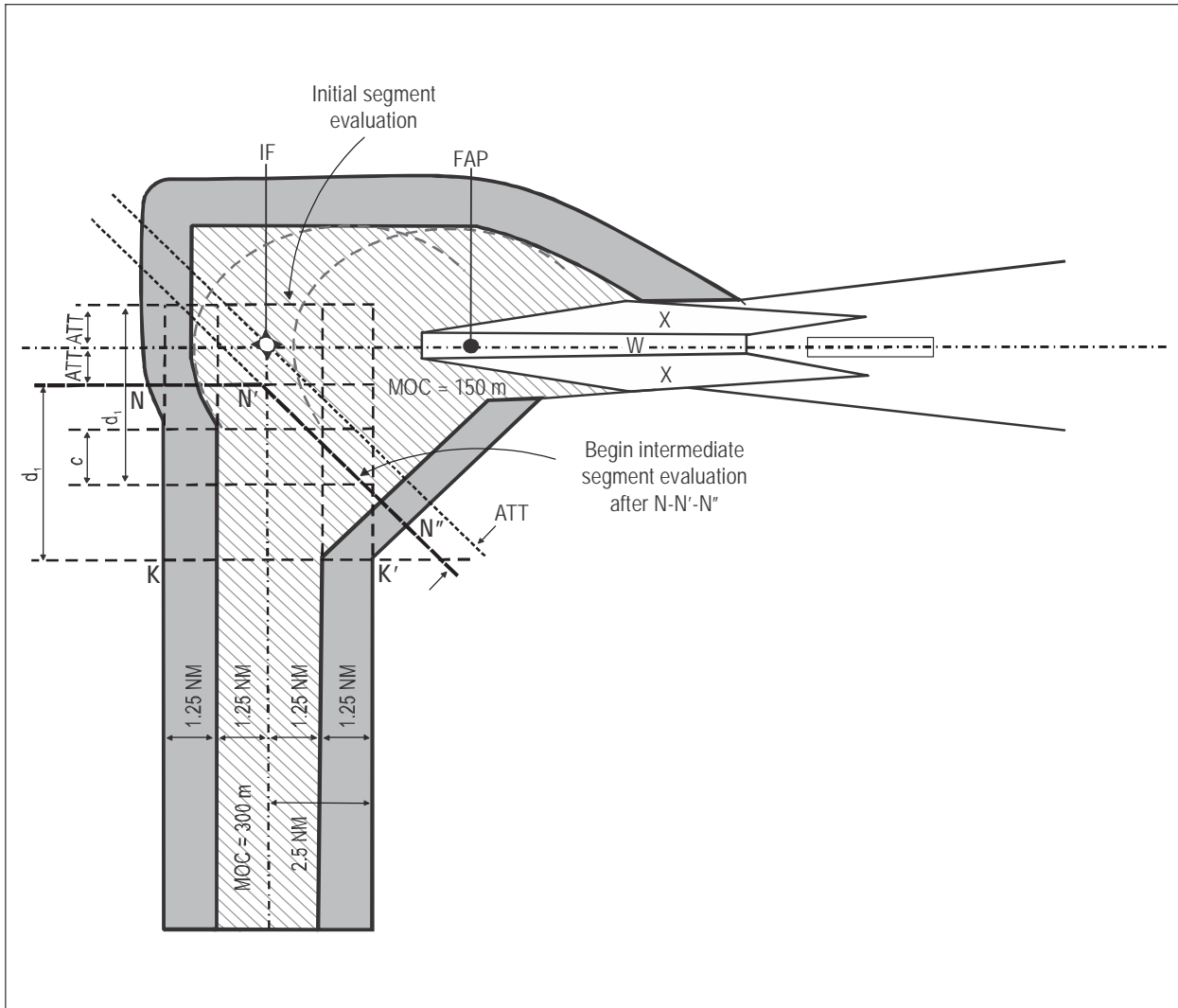

Figure II-1-3-7. Example: RNAV 1 or RNP 1 to MLS transition, 90° intercept (max)

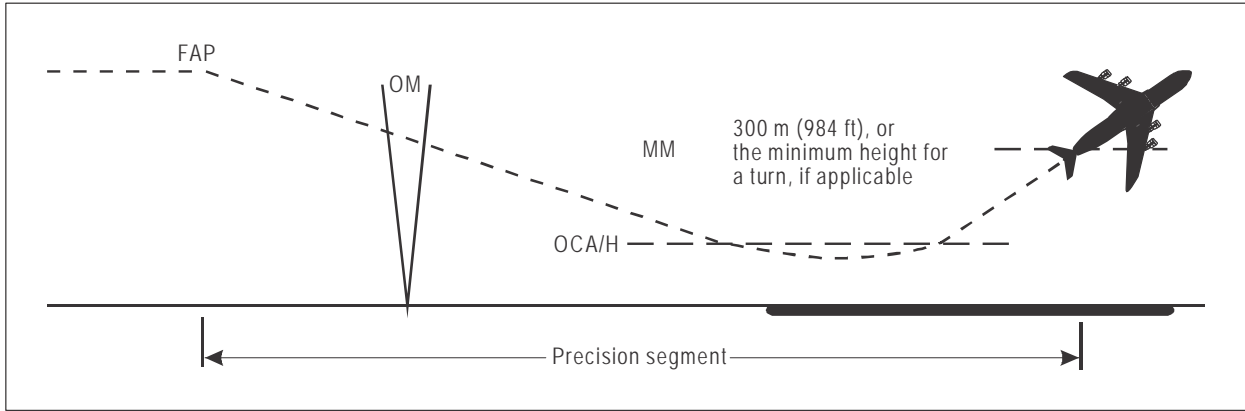

Figure II-1-3-8. Precision segment

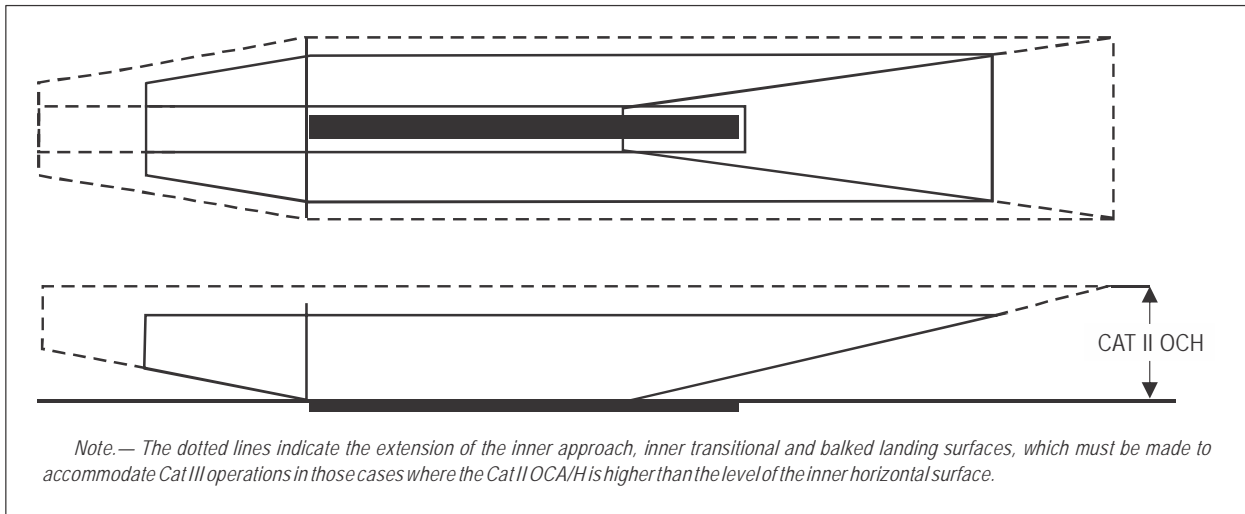

Figure II-1-3-9 a). Annex 14 inner approach, inner transitional and balked landing surfaces as applied for obstacle assessment for Cat II and III ILS operations

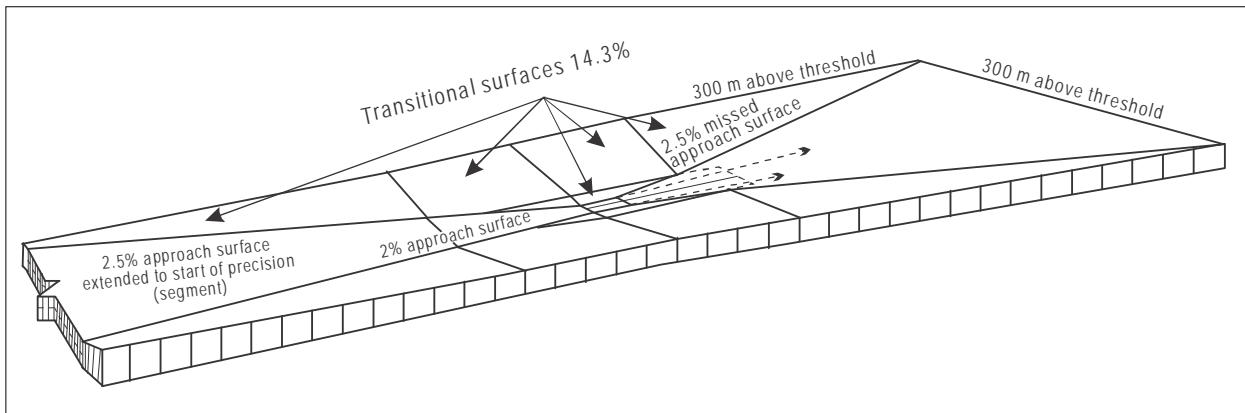

Figure II-1-3-9 b). Illustration of basic ILS surfaces as described in 3.4.7.2

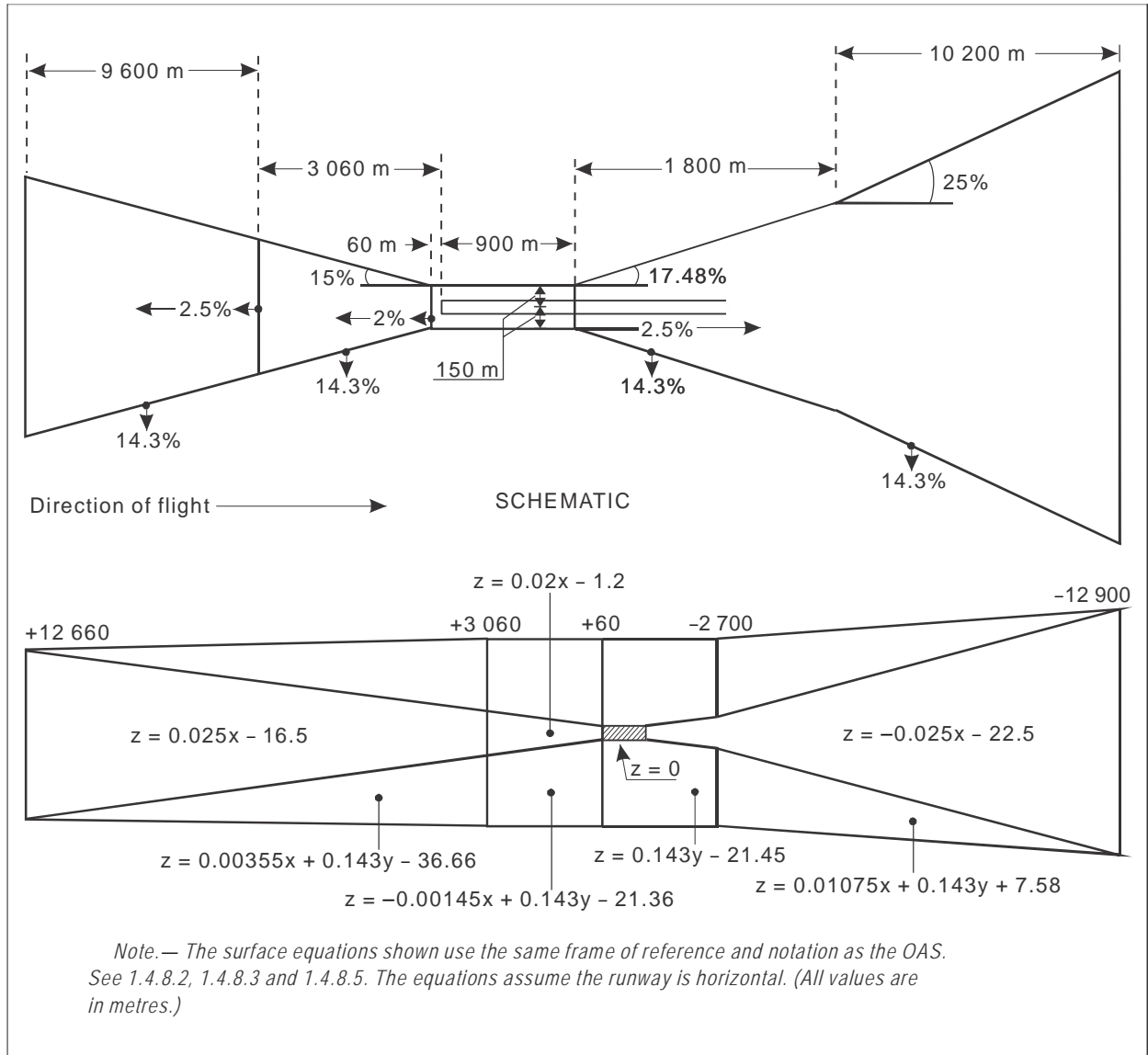

Figure II-1-3-10. Surface equations — basic ILS surfaces

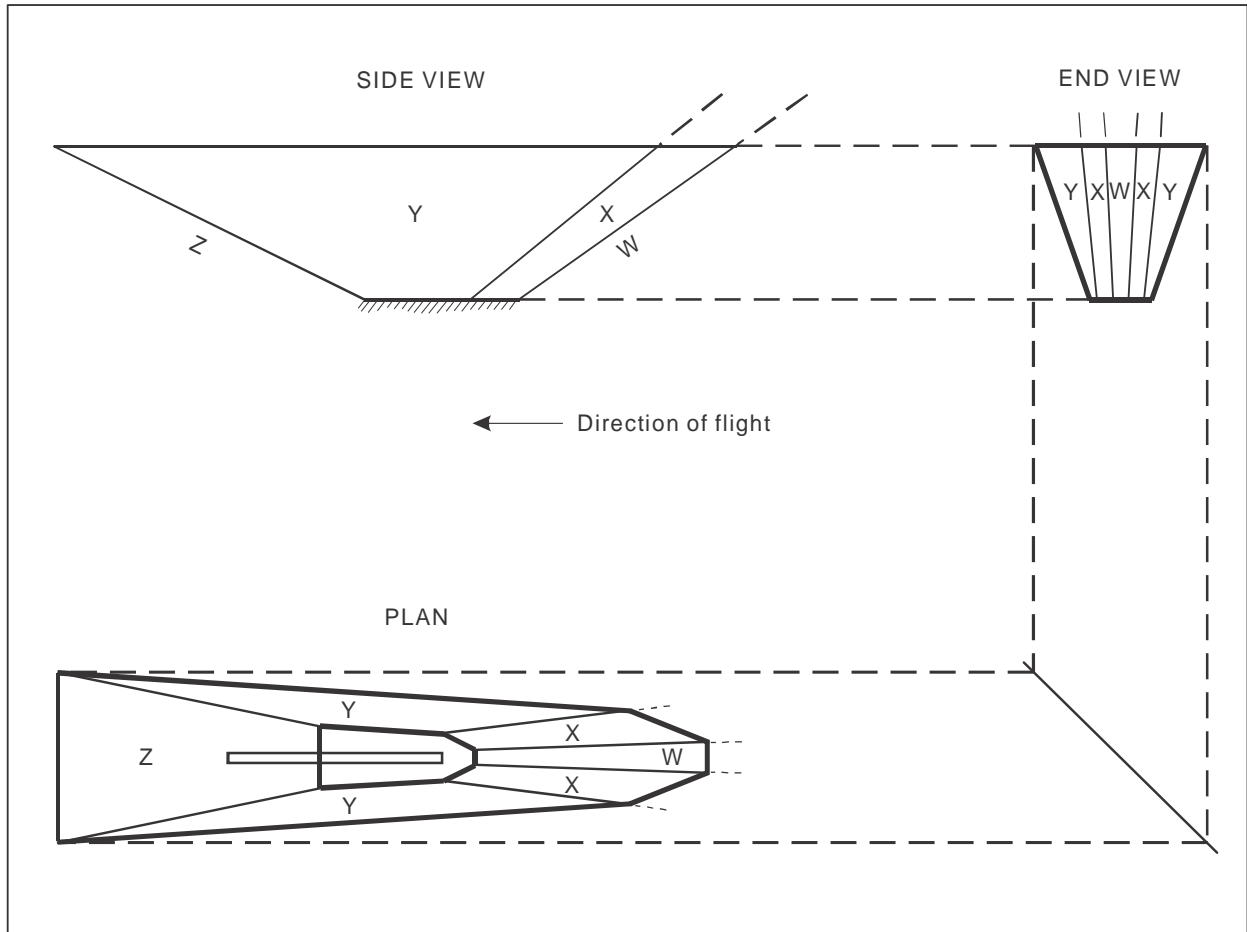

Figure II-1-3-11. Illustrations of ILS obstacle assessment surfaces

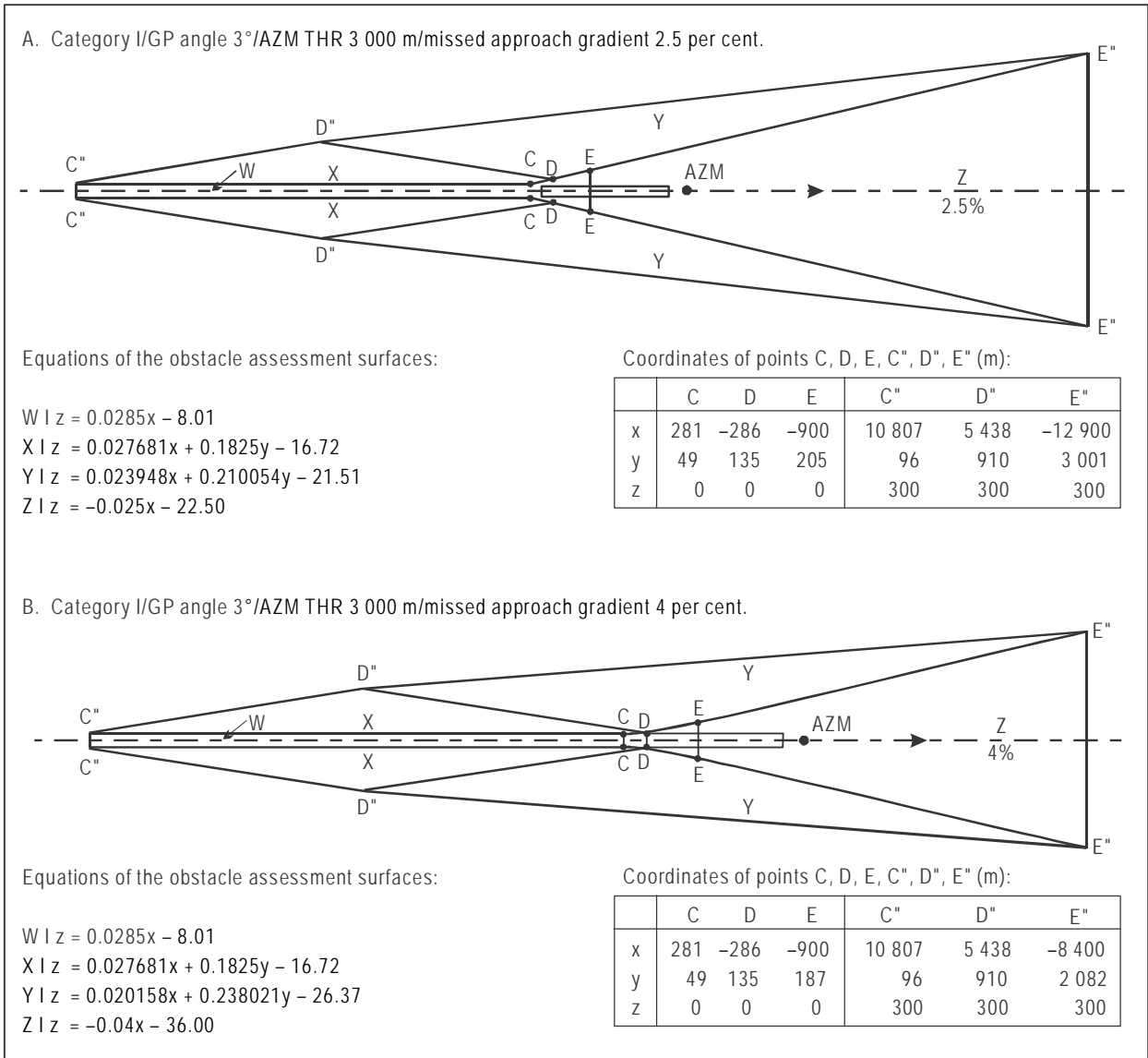

Figure II-1-3-14. Typical OAS contours for standard size aircraft

OAS

NAVIGATION AID DATA

Approach Category

Glide path (°) LOC THR Dist ⁽¹⁾ m

RDH m Course width at THR m

AIRCRAFT DATA

M/App CG (%) CAT STD Wing Semi Span m GP Wheel / Antenna height m

OAS constants

	A	B	C		A	B	C
W	<input type="text" value="0.028500"/>	<input type="text" value="0.000000"/>	<input type="text" value="-8.01"/>	Y	<input type="text" value="0.023948"/>	<input type="text" value="0.210054"/>	<input type="text" value="-21.51"/>
W*				Z	<input type="text" value="-0.025000"/>	<input type="text" value="0.000000"/>	<input type="text" value="-22.50"/>
X	<input type="text" value="0.027681"/>	<input type="text" value="0.182500"/>	<input type="text" value="-16.72"/>				

OAS Template coordinates -m (metres)

THR Elevation			300 m Height		
	X	Y		X	Y
C	<input type="text" value="281"/>	<input type="text" value="49"/>	C"	<input type="text" value="10807"/>	<input type="text" value="96"/>
D	<input type="text" value="-286"/>	<input type="text" value="135"/>	C'''		
E	<input type="text" value="-900"/>	<input type="text" value="205"/>	D"	<input type="text" value="5438"/>	<input type="text" value="910"/>
			E"	<input type="text" value="-12900"/>	<input type="text" value="3001"/>

OAS height calculator

X m Y m Z m

(1) For MLS read: "Azimuth antenna to THR distance"; for GBAS read: "GARP-LTP distance".

Figure II-1-3-15. OAS output data generated by the PANS-OPS OAS software

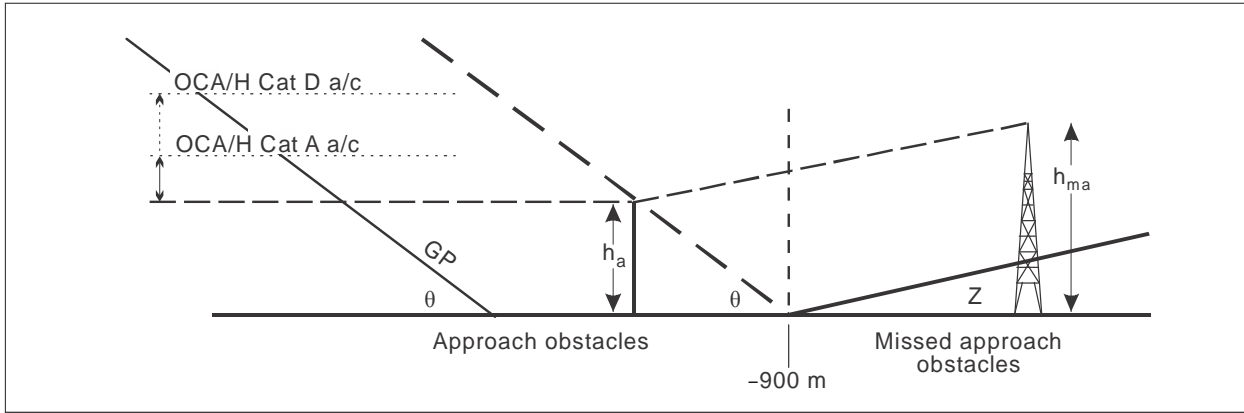

Figure II-1-3-16. Missed approach obstacle after range -900 m

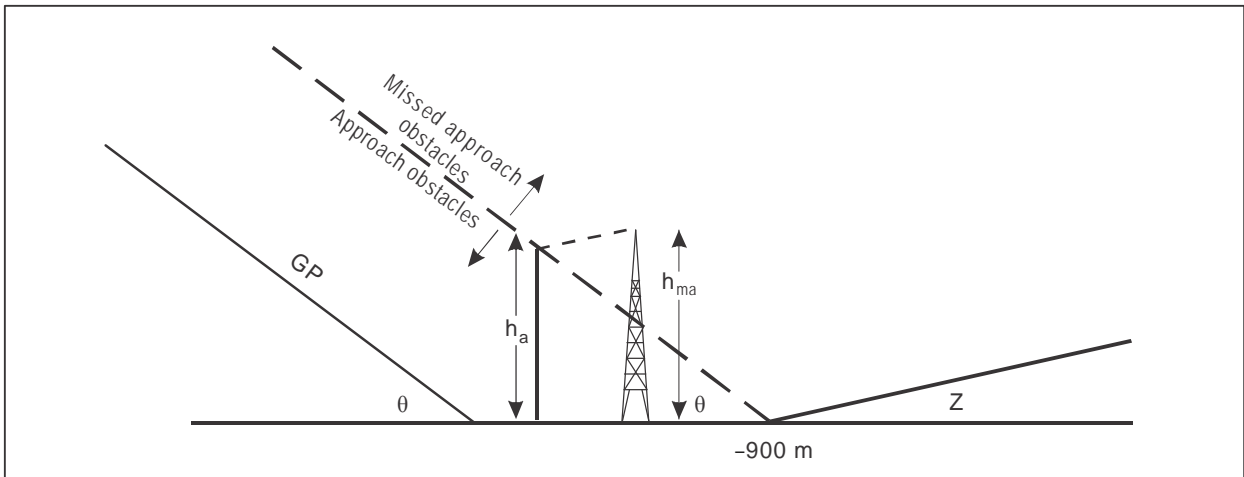

Figure II-1-3-17. Missed approach obstacle before range -900 m

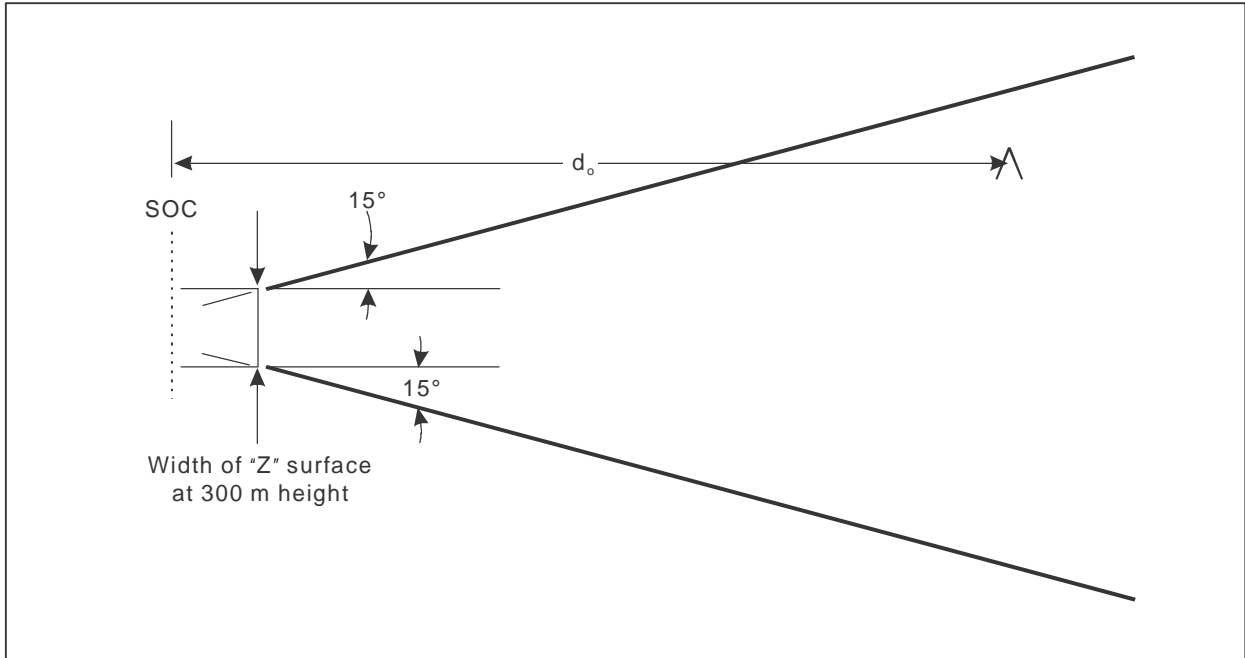

Figure II-1-3-18. Final segment of straight missed approach

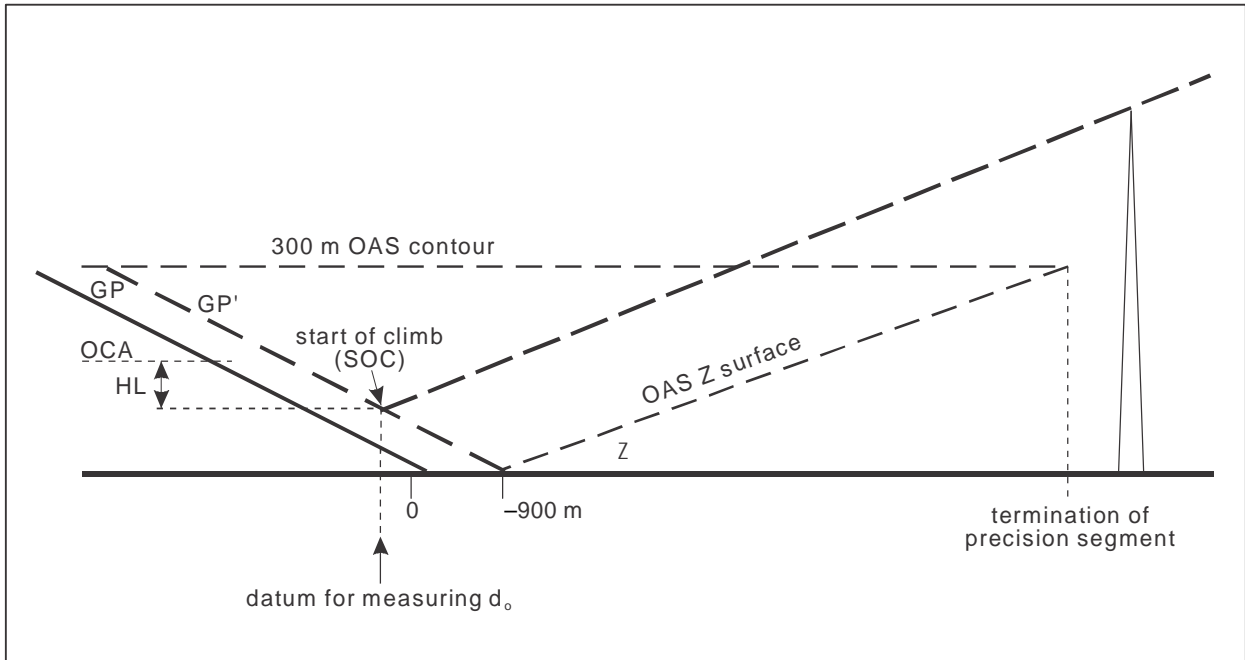

Figure II-1-3-19. Straight missed approach obstacle clearance

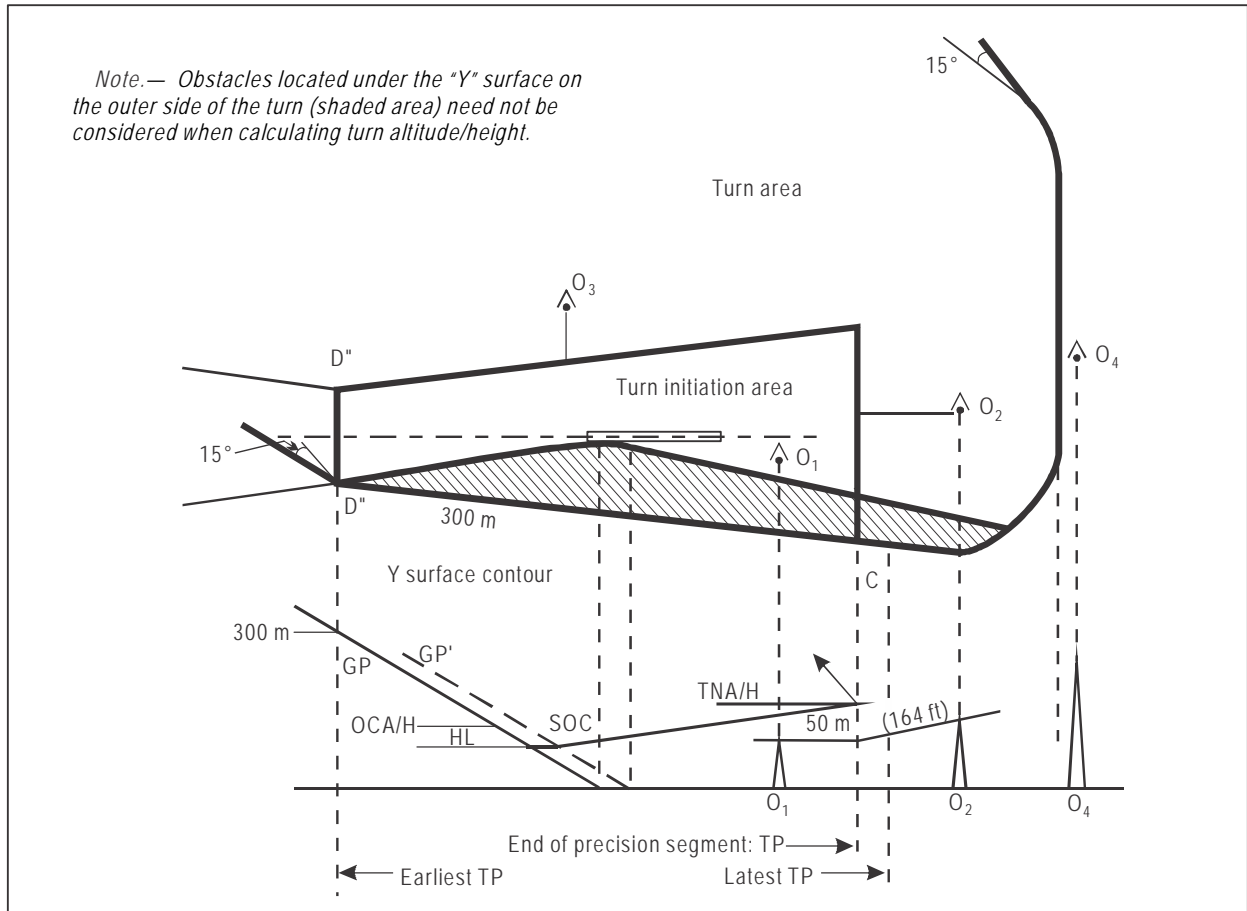

Figure II-1-3-20. Turn at a designated altitude

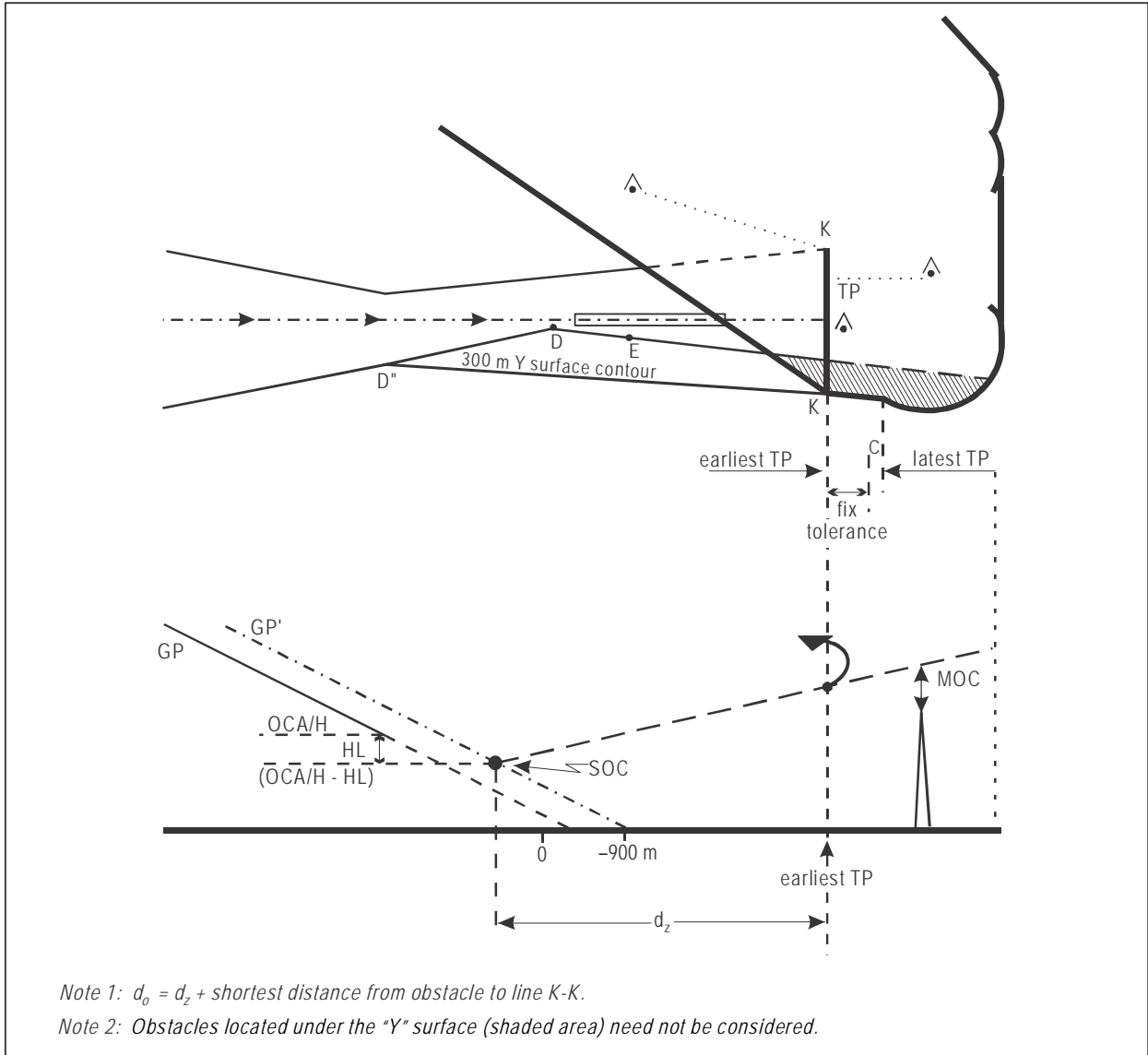

Figure II-1-3-21. Turn at designated TP (with TP fix)

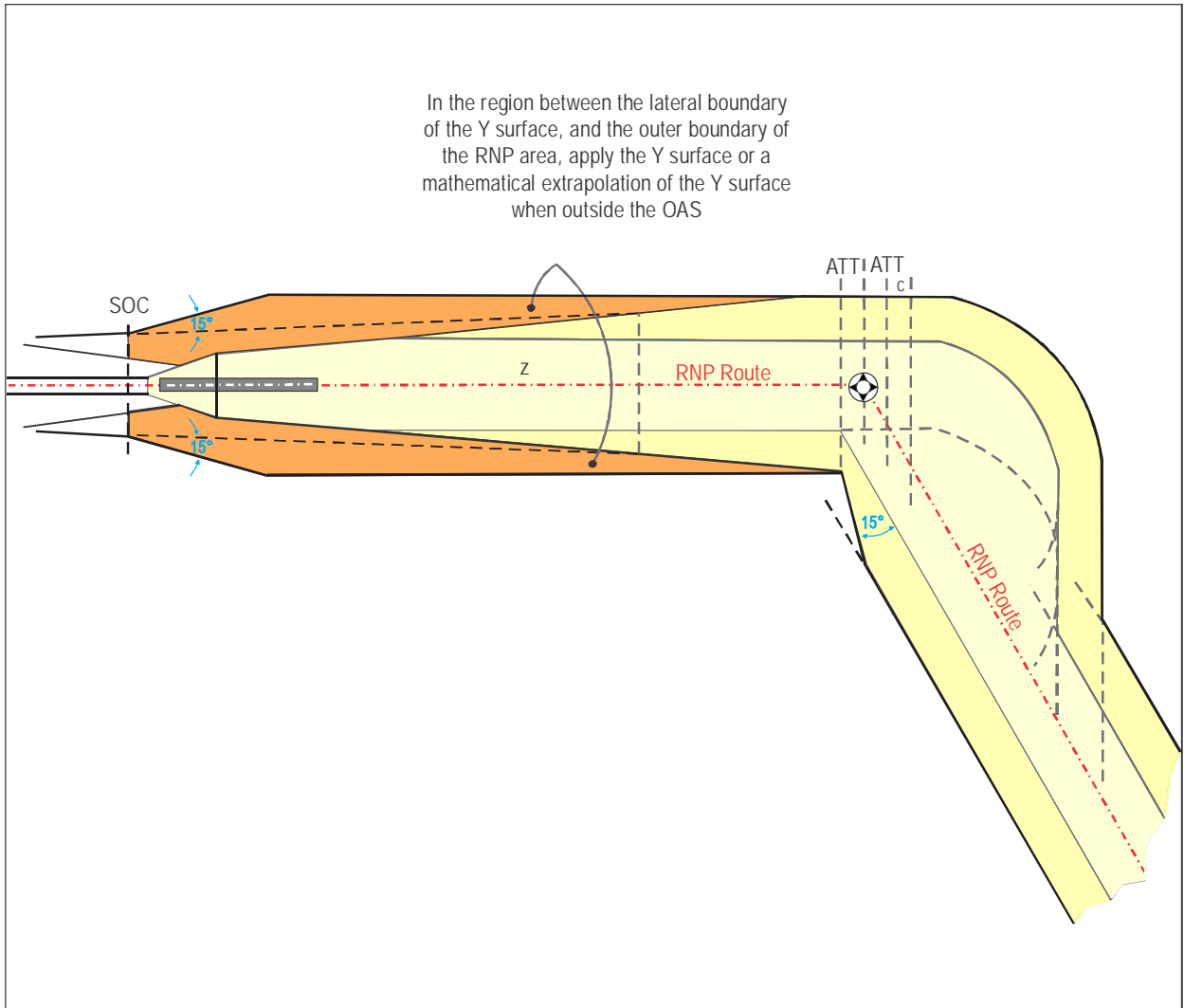

Figure II-1-3-22. Example: Transition to RNP 1, flyover turn after the precision segment

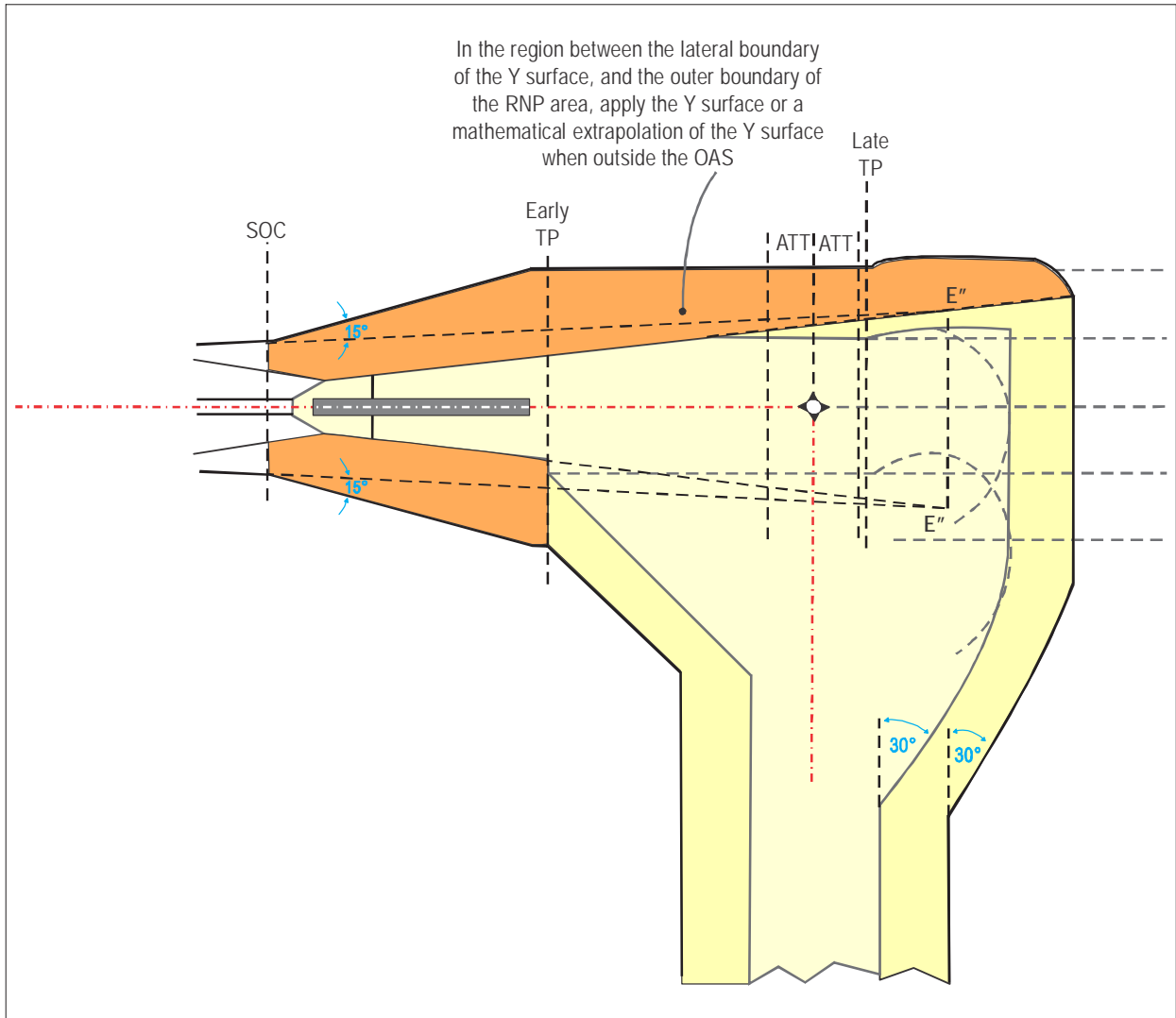

Figure II-1-3-23. Example: Transition to RNAV 1 or RNP 1, fly-by turn before the end of the precision segment

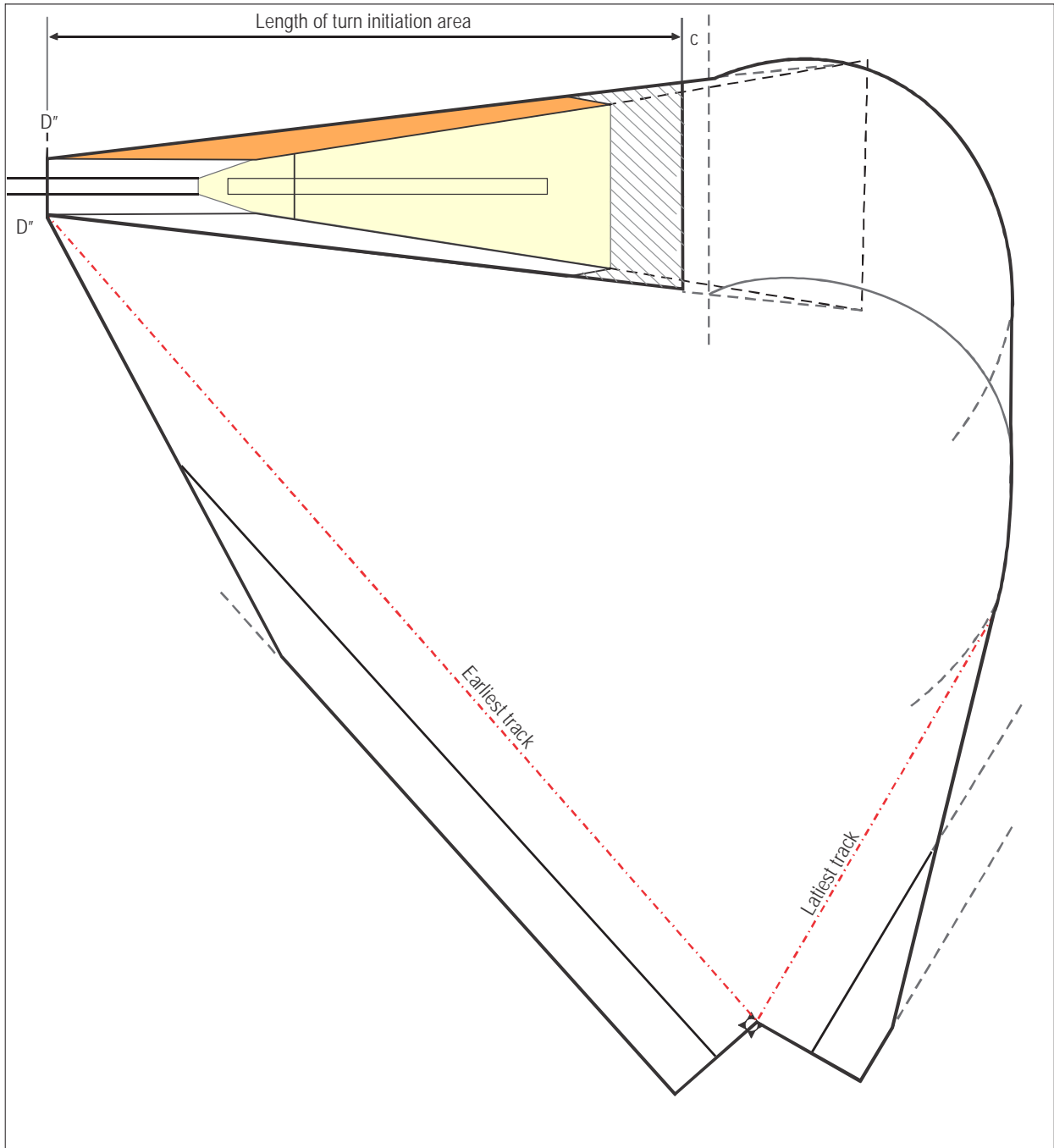

Figure II-1-3-24. Example: Turn at an altitude direct to an RNAV 1 or RNP 1 fix

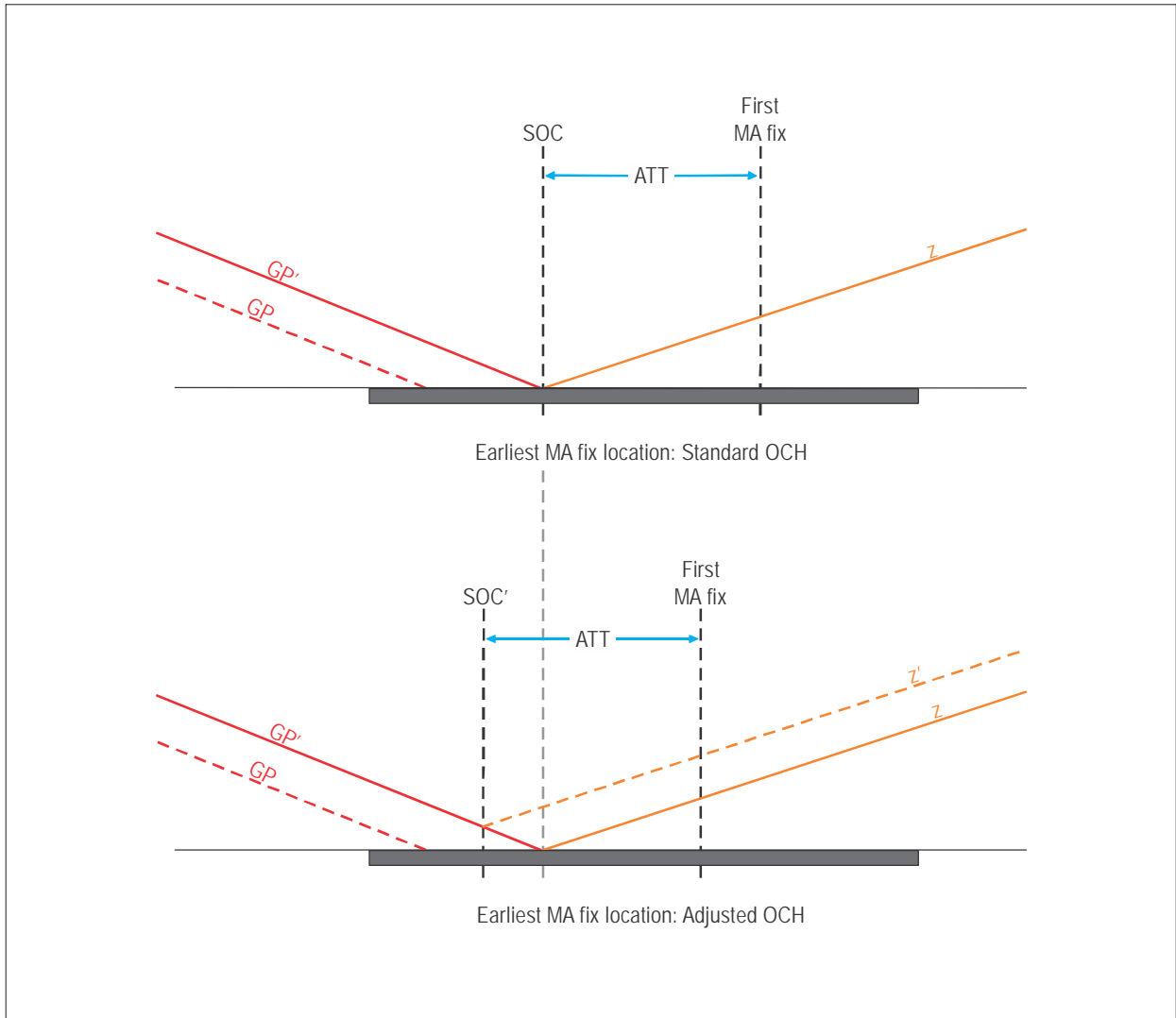

Figure II-1-3-25. Earliest fix location for RNAV or RNP missed approach

Chapter 4

OFFSET MLS

4.1 USE OF MLS CAT I WITH OFFSET AZIMUTH ALIGNMENT

4.1.1 The zero-degree azimuth shall intersect the runway extended centre line:

- a) at an angle not exceeding 5° ; and
- b) at a point where the nominal glide path (elevation angle) reaches a height of at least 55 m (180 ft) above threshold. This is called intercept height.

4.1.2 The procedure shall be annotated: “azimuth offset ... degrees” (tenth of degrees). The general arrangement is shown in Figure II-1-4-1.

4.2 OBSTACLE CLEARANCE CRITERIA

The provisions contained in Chapter 3 apply except that:

- a) all the obstacle clearance surfaces and calculations are based on a fictitious runway aligned with the azimuth specified for the final approach track. This fictitious runway has the same length, the same threshold elevation, and the same distance threshold to intercept point as the real one. The azimuth sector width and the MLS approach reference datum height are based on the threshold of the fictitious runway; and
- b) the OCA/H for this procedure shall be at least: intercept altitude/height + 20 m (66 ft).

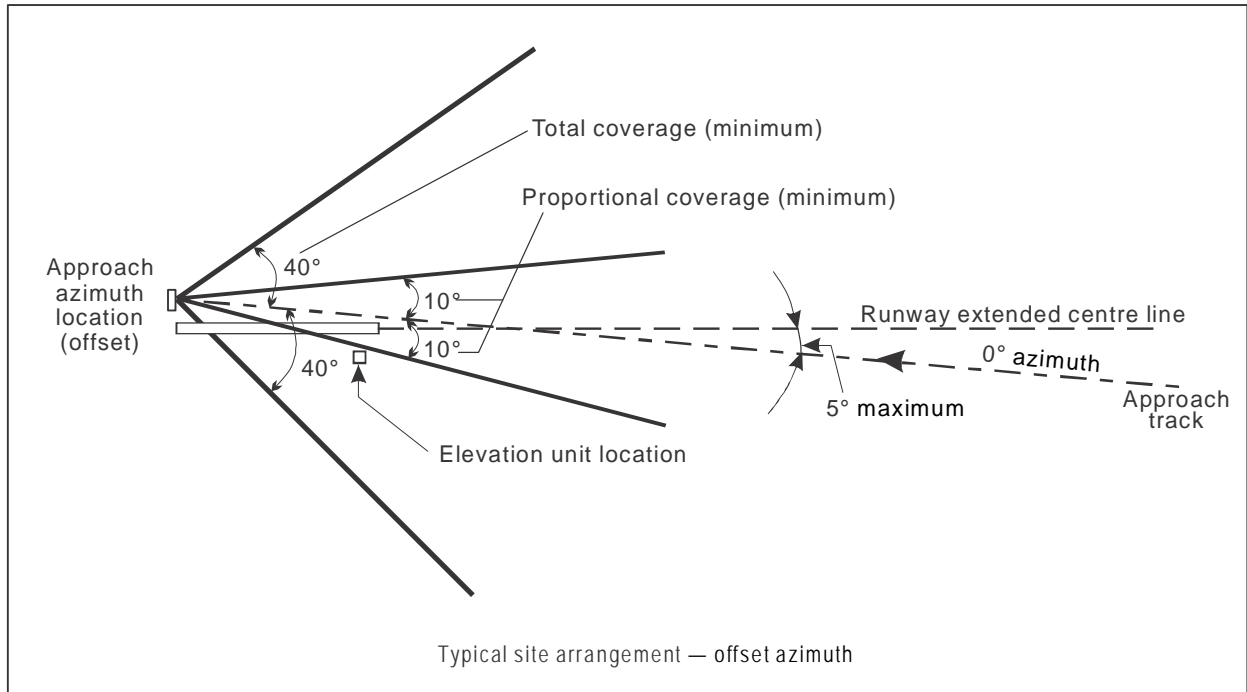

Figure II-1-4-1. Site arrangements suitable for MLS criteria application

Chapter 5

PAR

Note.— Only PAR approaches down to OCA/H of the order of 60 m (200 ft) have been considered.

5.1 ARRIVAL PHASE OPERATIONS

The arrival phase operations through initial and intermediate approach to the extended centre line of the runway will normally be made from an associated en-route navigation facility or within a radar vectoring area. This approach will be made on pre-determined tracks between such fixes or as directed by radar controllers within the radar vectoring area following radar identification. The time of flight from the last known fix should be sufficient to ensure that the radar identification procedure may be completed. In the event of radar contact not being established, or of the pilot becoming uncertain of his or her position, a return to the last fix should be prescribed.

5.2 INTERMEDIATE APPROACH

5.2.1 General

The interception with the descent path should be established at least 4 km (2 NM) inside the coverage of the radar.

5.2.2 Intermediate approach utilizing a suitable navigation facility or fix on or offset from the extended centre line of the runway

Routes shall be specified from the navigation facility, fix, predetermined tracks, or as directed by the radar controller, to intercept the extended centre line such that the aircraft, when aligned on the inbound track, is in a position from which the final approach can be started. The distance between the point of interception with the extended centre line and the interception with the descent path should be sufficient to permit the aircraft to stabilize (speed and configuration) and establish on the extended centre line prior to intercepting the descent path.

5.2.3 Length

The optimum length of the intermediate segment is 9 km (5 NM) (Cat H, 3.7 km (2.0 NM)). The minimum length depends upon the angle at which it is intercepted by the initial approach track and is specified in Table II-1-5-1. However, these minimum values should be used *only* if usable airspace is restricted.

5.2.4 Intermediate approach utilizing a suitable navigation facility or fix on the extended centre line of the runway

If a straight-in approach using such a facility on the extended centre line of the runway is possible, no special intermediate approach procedure is required other than radar identification.

5.2.5 Intermediate approach with no fix

Where no suitable navigation facility or fix is available for the procedures in 5.2.2 and 5.2.4 the procedure shall:

- a) ensure a track is available from the last positive fix at a suitable level above the MDA/H for the segments in question; and
- b) allow for identification turns in accordance with ATC instructions.

5.3 FINAL APPROACH

The procedure shall ensure that an aircraft on the inbound track of the extended runway centre line intercepts the glide path (minimum 2.5°, optimum 3.0°, maximum 3.5°) following radar control instructions at the altitude/height specified for the procedure which shall be at least 150 m (500 ft) above the horizontal part of the obstacle clearance surface (OCS). (See Figure II-1-5-1.) When instructed by radar of interception of descent path, descent is made in accordance with the radar controllers' instructions to the OCA/H.

Note.— The term obstacle clearance surface (OCS) is used only in precision approach radar procedures on the final approach.

5.4 MISSED APPROACH

The missed approach should normally be a track which is as near as possible a continuation of the final approach track after due consideration of obstructions, terrain and other factors influencing the safety of the operation (see 5.7).

5.5 ARRIVAL AND INITIAL APPROACH AREAS AND OBSTACLE CLEARANCES

5.5.1 Arrival and initial approach areas

The arrival and initial approach areas shall be at least 19 km (10 NM) wide (9.3 km (5.0 NM) either side of the predetermined track). Where navigation facilities are available which provide a very accurate track on initial approach, the distance of 9.3 km (5.0 NM) specified above may be reduced to a minimum of 5.6 km (3.0 NM). See Section 2, Chapter 6, 6.2.2, "Procedures based on predetermined tracks".

5.5.2 Arrival and initial approach obstacle clearances

The arrival and initial approaches shall not be made below an altitude which provides a clearance of 300 m (1 000 ft) above all obstacles within the area defined in Section 2, Chapter 6, 6.2.2, “Procedures based on predetermined tracks”. However, this altitude should not be lower than the altitude at which the glide path will be intercepted, and if a procedure turn is required not lower than the procedure turn altitude.

5.6 INTERMEDIATE AND FINAL APPROACH AREA AND OBSTACLE CLEARANCES

5.6.1 Combined intermediate and final approach area

5.6.1.1 This is an area symmetrical about the extended centre line extending from a point situated at a distance of D calculated as in 5.6.2.1 b) from the threshold to the point at which the final approach is commenced. The intermediate approach shall normally be commenced at a distance not exceeding 28 km (15 NM) from the threshold. The intermediate approach transforms into the final approach at the point where the aircraft intercepts the descent path.

5.6.1.2 The area has a constant width of 600 m from its origin at the distance D from the threshold as in 5.6.2.1 b), to a point 1 060 m before the threshold. From this point the area widens with a splay of 15 per cent on either side to a total width of 7.4 km (4.0 NM) at a distance of 24 km (13 NM) from the threshold, thence maintaining a constant width to the outer boundary of the joint intermediate/final approach area, normally not more than 28 km (15 NM) from the threshold (see Figures II-1-5-2, II-1-5-3 and II-1-5-4). Where the Annex 14 approach surface penetrates the approach surfaces and the initial missed approach surface shown in Figure II-1-5-2, the Annex 14 surface is used as the obstacle clearance surface.

Note 1.— In the event of D becoming greater than 1 060 m the figure of 1 060 m will be used.

Note 2.— The combined intermediate/final approach area corresponds to the extended area for instrument runways specified in Annex 14.

Note 3.— The length of the final approach area is limited by the convergence of the radar.

5.6.2 Intermediate and final approach obstacle clearances

5.6.2.1 The minimum obstacle clearance above obstacles within the limits of the intermediate and final approach area shall be as specified herein:

- a) from the beginning of intermediate approach, the obstacle clearance surface shall be the horizontal plane whose height is equal to that of the highest obstacle in the intermediate approach area, to the point where this surface intersects the plane described under b) hereafter; the obstacle clearance above this plane shall not be less than 150 metres (500 feet) up to a point where the obstacle clearance intersects the plane described under b); and
- b) thereafter, within the final approach area, the obstacle clearance surface is contained in a plane inclined at an angle not greater than 0.6θ . This plane intersects the horizontal plane through the threshold in a line at right angles to the runway centre line, at a distance D before the threshold, where:

$$D = \frac{30}{\tan 0.6 \theta} - \frac{H}{\tan \theta} \quad (D \text{ and } H \text{ in metres})$$

or

$$D = \frac{98}{\tan 0.6 \theta} - \frac{H}{\tan \theta} \quad (\text{D and H in feet})$$

- where: θ = nominal glide path angle;
- 0.6θ = worst assumed descent path angle; and
- H = height of the nominal descent path over the threshold.

5.6.2.2 The final approach OCA/H is obtained by adding the values for pressure altimeter from Section 1, Chapter 1, Table II-1-1-2 to the highest obstruction penetrating the plane defined in 5.6.2.1 b), or to the highest obstruction in the initial missed approach area, whichever is higher. (See Figure II-1-5-5.) It must also assure missed approach obstacle clearance is provided (see 5.7.2.2).

5.7 MISSED APPROACH AREA AND OBSTACLE CLEARANCE

5.7.1 Missed approach area

The initial phase of the missed approach area starts at the MAPt which is at the end of the final approach area (i.e. at a distance D before the threshold). The initial phase continues from there with a constant width of 600 m, there being 300 m on either side of the runway centre line, to a distance of not less than 900 m nor normally, more than 1 800 m beyond the threshold. At this point, the intermediate phase of the missed approach area commences. This intermediate phase is an area symmetrical about the missed approach track extending a sufficient distance to ensure that an aircraft climbing at a gradient of 2.5 per cent has reached an altitude at which a major turn can be initiated, acceleration may commence or obstacle clearances (such as for en route or holding) become effective. (See Part I, Section 4, Chapter 6, 6.2.2, “Intermediate phase”). The width of the intermediate phase of the missed approach area is 600 m until it reaches 1 800 m beyond the threshold or reaches the runway end, whichever is the least, then widening with a splay of 15° on either side. The final phase shall be in accordance with criteria contained in Part I, Section 4, Chapter 6. Where positive radar guidance is provided throughout the missed approach procedure, the splay may be reduced to a minimum of 10°. Criteria for additional track guidance is contained in Part I, Section 4, Chapter 6, 6.3.2.3, “Additional track guidance”.

Note.— In determining the missed approach area for a particular runway, the following considerations are pertinent:

- a) *the maximum distance from the threshold of 1 800 m for the commencement of the assumed gradient of 2.5 per cent may be unduly restrictive for certain aircraft operations and where this is so, this point may be varied to suit the conditions existing, but in any case the commencing point should not be less than 900 m from the threshold; and*
- b) *the angular deviations of 10° and 15° allow for pilot ability to maintain track during missed approach with or without radar guidance.*

5.7.2 Missed approach obstacle clearance

5.7.2.1 The minimum vertical clearance above all obstacles in the missed approach area shall be 30 m (98 ft).

5.7.2.2 The OCA/H for the intermediate phase of the missed approach area is determined by assuming a missed approach climb gradient that clears all obstacles in the intermediate phase of the missed approach area by at least 30 m (98 ft). This OCA/H for missed approach shall be the height at which a 2.5 per cent plane, passing at least 30 m (98 ft)

above any object in the intermediate phase of the missed approach area intersects in a horizontal line a vertical plane at right angles to the runway centre line and situated at the beginning of the intermediate phase of the missed approach area. The OCA/H shall also assure that MOC in the final phase of the missed approach is provided. See Part I, Section 4, Chapter 6.

5.7.3 Obstacle clearance altitude/height

The OCA/H published for the procedure shall be the higher of the values calculated in 5.6.3.1 and 5.7.2.1, but it shall not be less than 60 m (200 ft). See Figures II-1-5-1 and II-1-5-5.

Table II-1-5-1. Minimum length of intermediate segment

<i>Intercept angle with localizer (degrees)</i>	<i>Minimum distance between localizer and glide path interceptions</i>	
	Cat A to E	Cat H
0 – 15	2.8 km (1.5 NM)	2.8 km (1.5 NM)
16 – 30	3.7 km (2.0 NM)	3.7 km (2.0 NM)
31 – 60	4.6 km (2.5 NM)	3.7 km (2.0 NM)
61 – 90	5.6 km (3.0 NM)	3.7 km (2.0 NM)

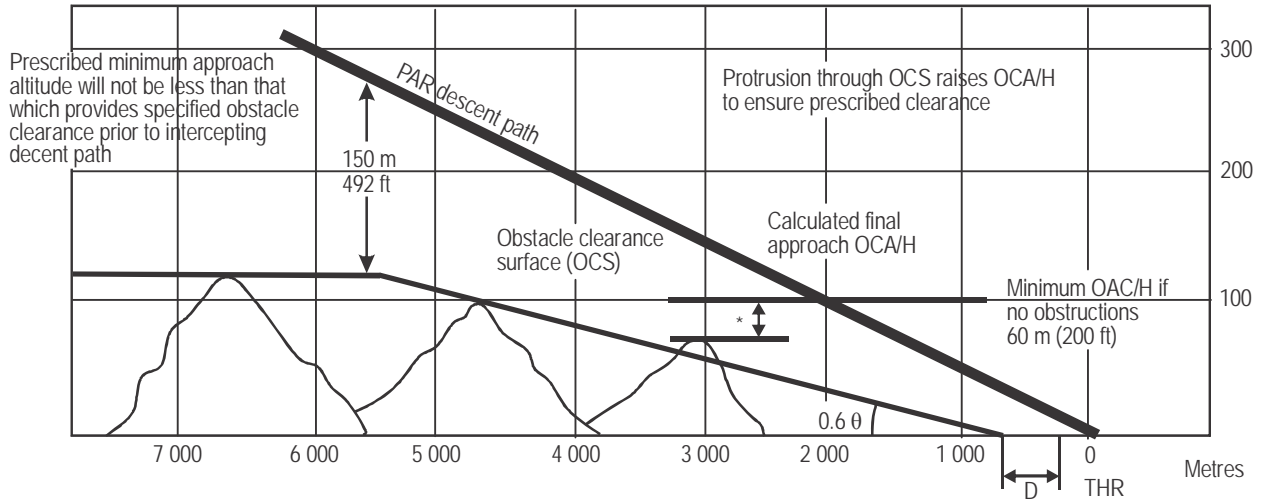

* Height loss from Section 1, Chapter 1, Table II-1-1-2

Figure II-1-5-1. Determination of final approach OCA/H for PAR

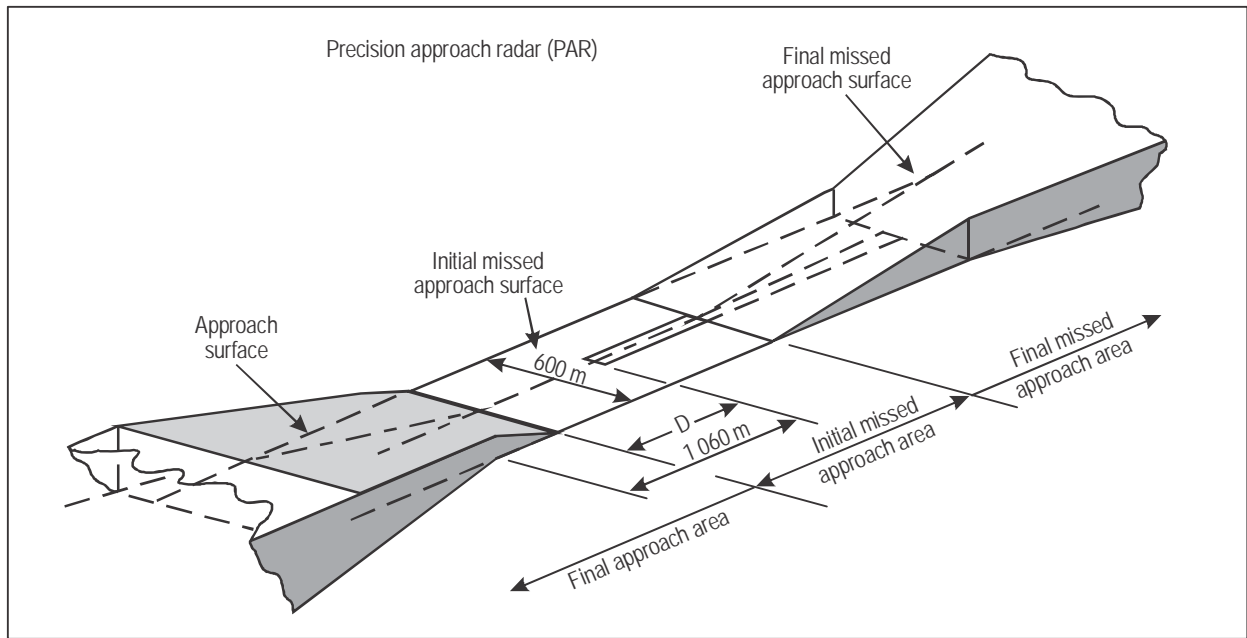

Figure II-1-5-2. Final approach and missed approach areas and surfaces

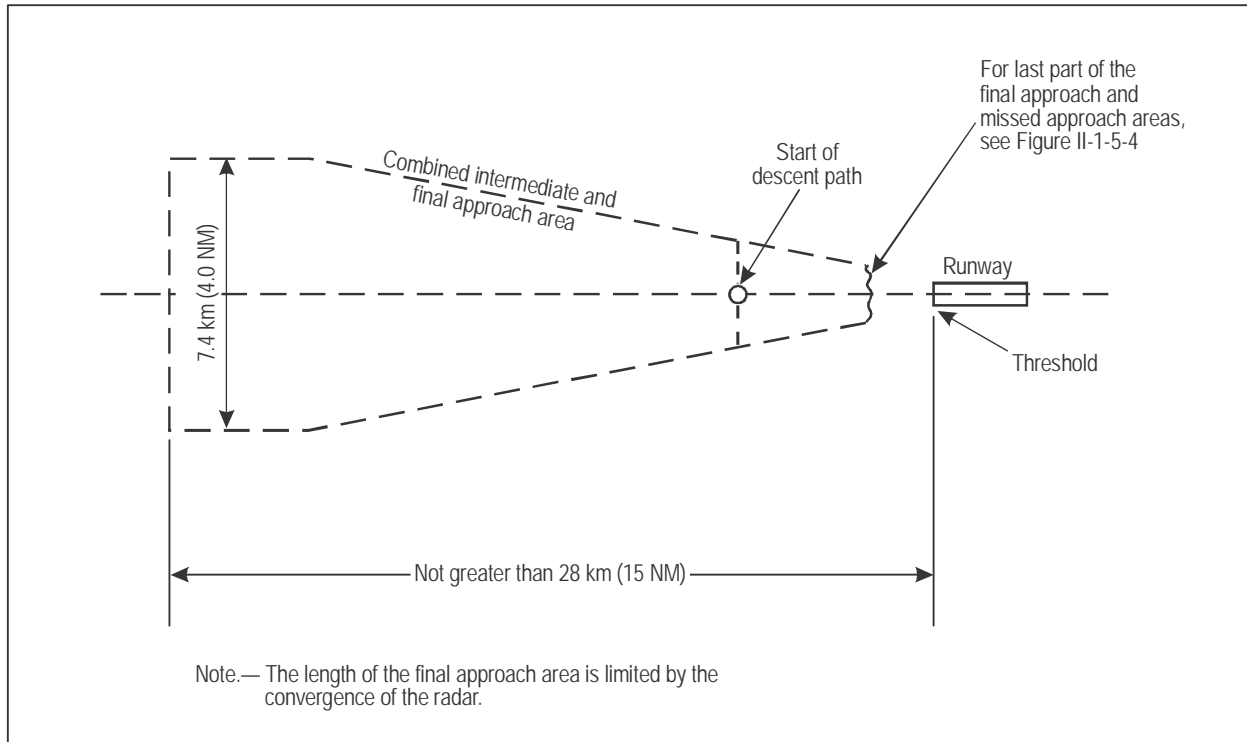

Figure II-1-5-3. Intermediate approach area precision approach radar

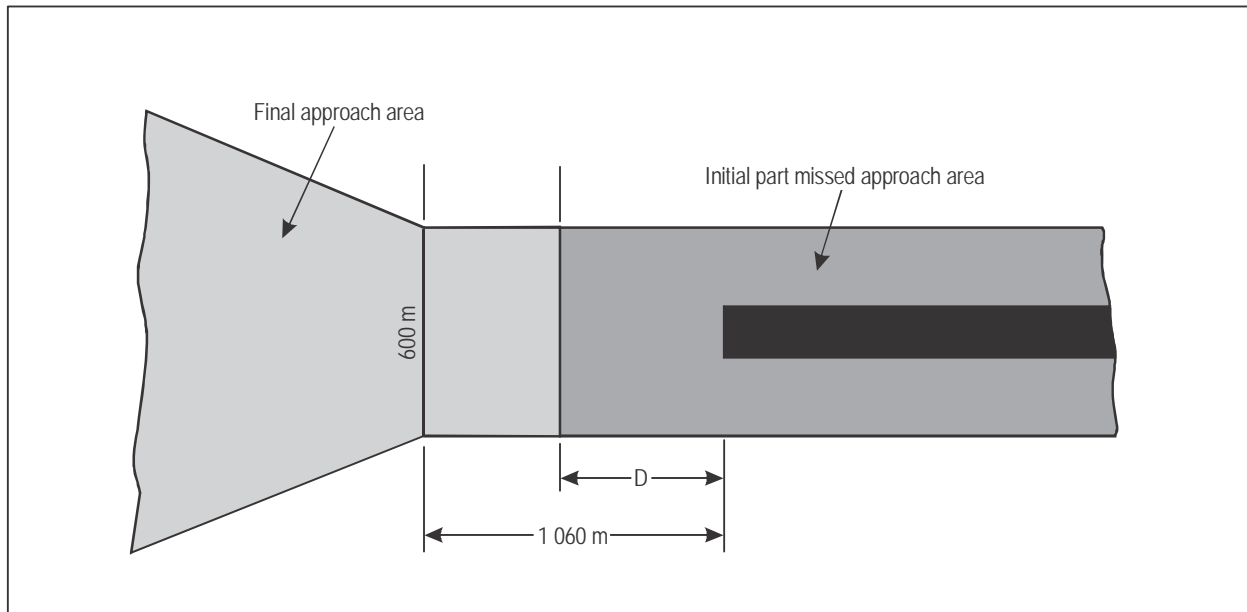

Figure II-1-5-4. Final and initial missed approach areas precision approach radar

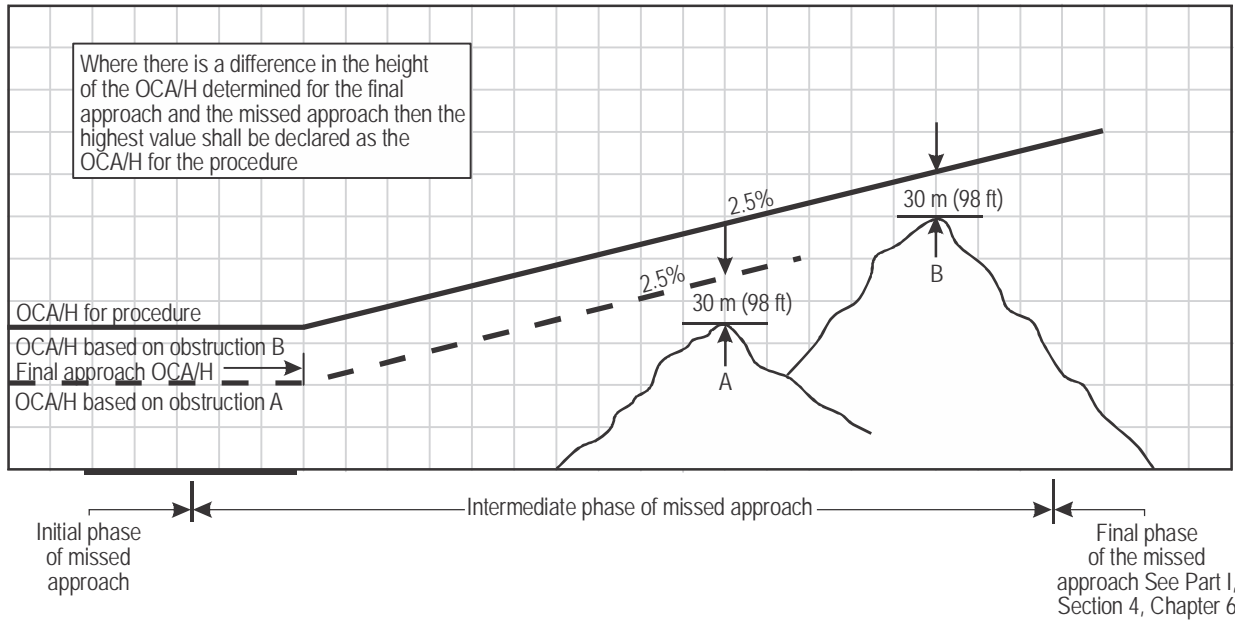

Figure II-1-5-5. Determination of missed approach OCA/H for PAR

Section 2

NON-PRECISION APPROACHES

Chapter 1

LOC ONLY

1.1 GENERAL

The localizer only procedure is a non-precision approach procedure. The general criteria apply with the following exceptions.

1.2 INTERMEDIATE APPROACH

The intermediate approach segment shall terminate at the FAF (outer marker or any fix meeting the FAF requirements). The width of the primary and secondary areas shall meet the criteria specified in Section 1, Chapter 1, 1.3.4, “Intermediate approach segment area width”, the FAP being replaced by the FAF.

1.3 FINAL APPROACH AND MISSED APPROACH SEGMENT

1.3.1 Beginning and end

The final approach segment shall start at the FAF. It shall terminate at the MAPt, which shall not be beyond the threshold.

1.3.2 Alignment

In general, the localizer antenna is sited on the runway centre line; nevertheless, in some cases this is not possible. In this case, the alignment of the final approach track with the runway centre line determines whether a straight-in or circling approach may be established. (See general criteria of Part I, Section 4, Chapter 5, 5.2, “Alignment”.)

1.3.3 Areas

1.3.3.1 The final approach/initial missed approach area is defined by the outer edges of the OAS X surfaces appropriate to the ILS Category I procedure between the FAF and the distance where those edges reach a height 300 m (984 ft) above threshold level. After that point, the area shall be equal in width to the 300 m (984 ft) Y surface contour (see Figure II-2-1-1).

1.3.3.2 Where there is no glide path a 3° glide path angle shall be used when determining the 300 m (984 ft) OAS contour.

1.3.3.3 The X and Y surfaces mentioned above may be replaced by the approach and extended transitional surfaces defined in items a) and d) of Section 1, Chapter 1, 1.4.7.2, “Definition of basic ILS surfaces”.

1.3.3.4 In the final approach and missed approach areas, those areas bounded by the lines joining points D, D”, E” and E are treated as secondary areas.

1.3.3.5 The final approach/initial missed approach areas terminate at the end of the transitional tolerance area as determined in the general criteria (see Part I, Section 4, Chapter 6; see also Part I, Section 2, Chapter 2, 2.6.4.2, “Use of 75 MHz marker beacon” and Part I, Section 4, Chapter 6, 6.1.6.2, “Determining SOC with an MAPt defined by a navigation facility or fix” for use of markers as missed approach points).

1.3.3.6 For turning missed approaches the general criteria in Part I, Section 4, Chapter 6, 6.4, “Turning missed approach” may be applied from the end of the transitional tolerance area.

1.3.3.7 The straight missed approach area is defined by the width of the 300 m (984 ft) Y surface contour to point E” (see Figure II-2-1-1) after which the splay increases to 15 degrees.

1.3.4 Obstacle clearance

The MOC is 75 m (246 ft) in the primary area, reducing to zero at the outer edges of the secondary areas. The general criteria apply except that obstacles in the secondary areas underlying the OAS Y surfaces are only considered if they penetrate those surfaces, in which case the required obstacle clearance is determined as in Part I, Section 2, Chapter 1, Figure I-2-1-3, and Figure II-2-1-2. See Part I, Section 2, Chapter 1, 1.7, “Increased altitudes/heights for mountainous areas” regarding increased altitudes/heights for mountainous areas.

1.3.5 Descent gradient for an ILS procedure with glide path inoperative

This type of procedure is associated with glide path failure. Therefore it is recommended, when possible, to specify the same descent gradient for both the ILS procedure with glide path inoperative and the corresponding ILS procedure (see Annex 4, 11.10.8.5).

1.4 PROMULGATION

1.4.1 The general criteria in Part I, Section 2, Chapter 1, 1.11, “Promulgation” apply. The instrument approach chart for a localizer-only approach procedure shall be identified by the title LOC RWY XX. If the localizer-only approach is published on the same chart as the ILS approach, the chart shall be entitled ILS or LOC RWY XX. If a DME is required it shall be indicated in a note on the chart.

1.4.2 For promulgation of procedure altitudes/heights and the descent gradient/angle for an ILS procedure with glide path inoperative, see Part I, Section 4, Chapter 5, 5.5, “Promulgation”.

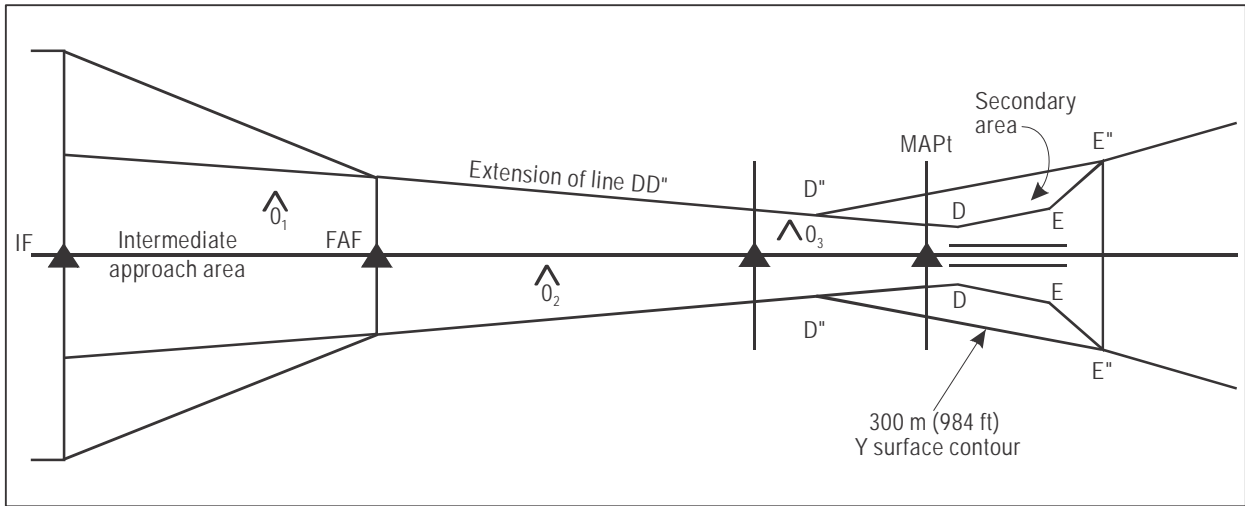

Figure II-2-1-1. Localizer-only procedure — areas

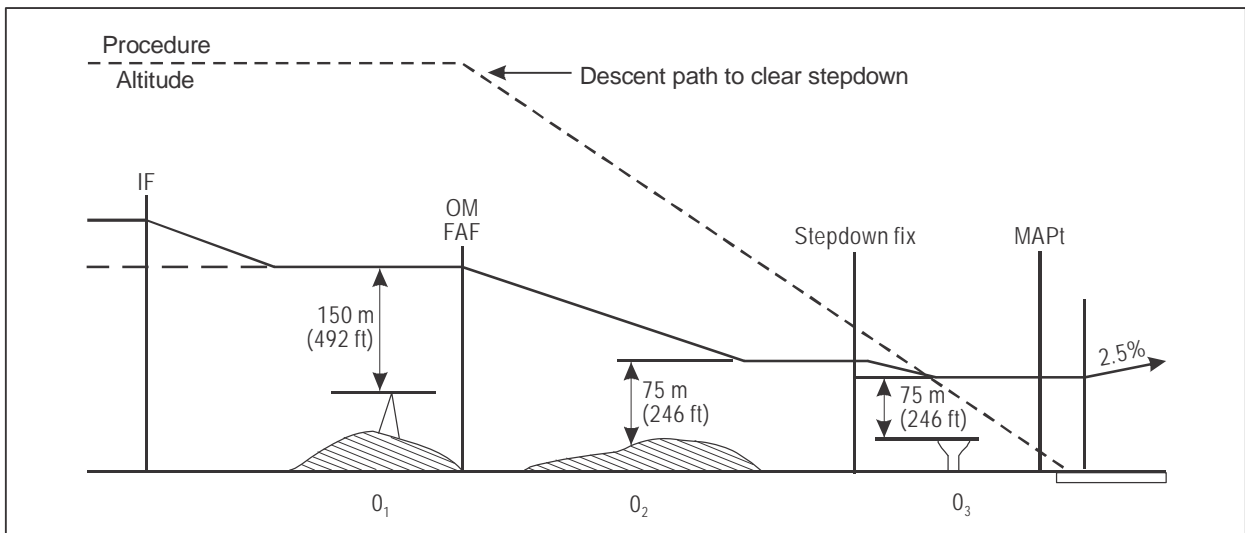

Figure II-2-1-2. Localizer-only procedure — obstacle clearance and procedure altitude

Chapter 2

MLS AZIMUTH ONLY

2.1 GENERAL

The azimuth-only procedure is a non-precision approach procedure. The general criteria apply with the following exceptions.

2.2 INTERMEDIATE APPROACH

The intermediate approach segment shall terminate at the FAF (outer marker or any fix meeting the FAF requirements). The width of the primary and secondary areas shall meet the criteria specified in Section 1, Chapter 3, 3.3.4, “Intermediate approach segment area width”, the FAP being replaced by the FAF.

2.3 FINAL APPROACH AND MISSED APPROACH SEGMENT

2.3.1

The final approach segment shall start at the FAF. It shall terminate at the MAPt, which shall not be beyond the threshold.

2.3.2 Alignment

In general, the azimuth antenna is sited on the runway centre line; nevertheless, in some cases this is not possible. In this case, the alignment of the final approach track with the runway centre line determines whether a straight-in or circling approach may be established (see general criteria of Part I, Section 4, Chapter 5, 5.2, “Alignment”).

2.3.3 Areas

2.3.3.1 The final approach/initial missed approach area is defined by the outer edges of the ILS OAS X surfaces appropriate to the MLS Category I procedure from the FAF to the range where those edges reach a height 300 m (984 ft) above threshold level. After that range the area shall be equal in width to the 300 m (984 ft) Y surface contour (see Figure II-2-2-1).

2.3.3.2 Where there is no glide path a 3° glide path angle shall be used when determining the 300 m (984 ft) OAS contour.

2.3.3.3 The X and Y surfaces may be replaced by the approach and extended transitional surfaces defined in items a) and c) of Section 1, Chapter 3, 3.4.7.2, “Definition of basic ILS surfaces”.

2.3.3.4 In the final approach and missed approach areas, those areas bounded by the lines joining points D, D”, E” and E are treated as secondary areas.

2.3.3.5 The final approach/initial missed approach areas terminate at the end of the transitional tolerance area as determined in the general criteria (see Part I, Section 4, Chapter 6; see also Part I, Section 2, Chapter 2, 2.6.4.2, “Use of 75 MHz marker beacon” and Part I, Section 4, Chapter 6, 6.1.6.2, “Determining SOC with an MAPt defined by a navigational facility or fix” for use of markers as missed approach points).

2.3.3.6 For turning missed approaches the general criteria in Part I, Section 4, Chapter 6, 6.4, “Turning Missed Approach” may be applied from the end of the transitional tolerance area.

2.3.3.7 The straight missed approach area is defined by the width of the 300 m (984 ft) Y surface contour to point E” (see Figure II-2-2-1) after which the splay increases to 15 degrees.

2.3.4 Obstacle clearance

The MOC is 75 m (246 ft) in the primary area, reducing to zero at the outer edges of the secondary areas. The general criteria apply except that obstacles in the secondary areas underlying the OAS Y surfaces are only considered if they penetrate those surfaces, in which case the required obstacle clearance is determined as in Part I, Section 2, Chapter 1, Figure I-2-1-3, and Figure II-2-2-2. See Part I, Section 2, Chapter 1, 1.7, “Increased altitudes/heights for mountainous areas” regarding increased altitudes/heights for mountainous areas.

2.3.5 Descent gradient for an MLS procedure with glide path inoperative

This type of procedure is associated with glide path failure. Therefore it is recommended, when possible, to specify the same descent gradient for both the MLS procedure with glide path unserviceable and the corresponding MLS procedure (see Annex 4, 11.10.8.5).

2.4 PROMULGATION

2.4.1 The general criteria in Part I, Section 2, Chapter 1, 1.11, “Promulgation” apply. The instrument approach chart for an azimuth-only approach procedure shall be identified by the title LOC Rwy XX. If the azimuth-only approach is published on the same chart as the MLS approach, the chart shall be entitled MLS or LOC Rwy XX. If a DME is required it shall be indicated in a note on the chart.

2.4.2 For promulgation of procedure altitudes/heights and the descent gradient/angle for an MLS procedure with azimuth-only, see Part I, Section 4, Chapter 5, 5.5, “Promulgation”.

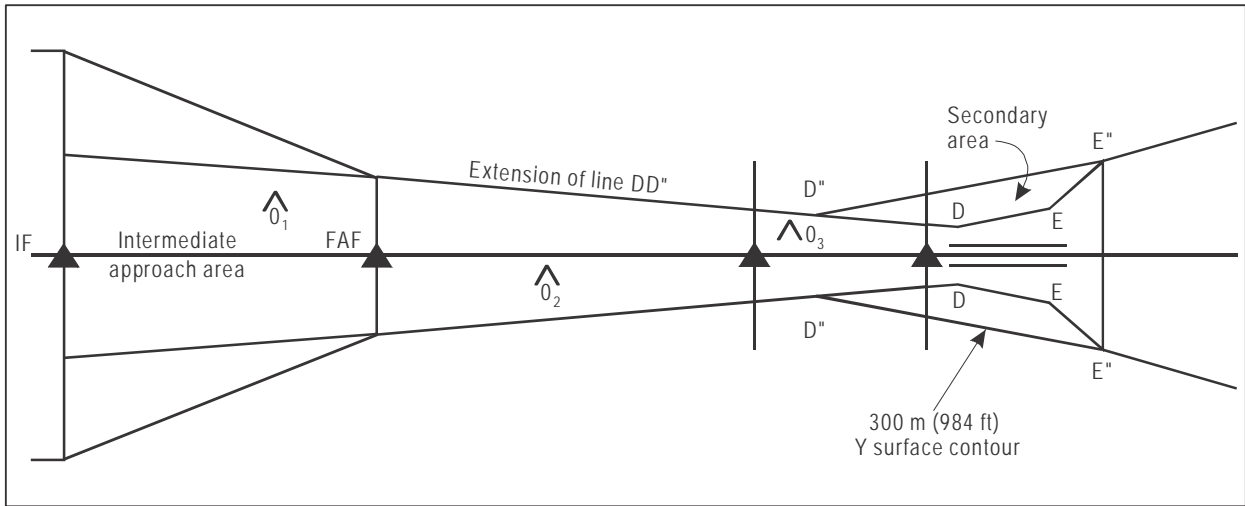

Figure II-2-2-1. Azimuth-only procedure — areas

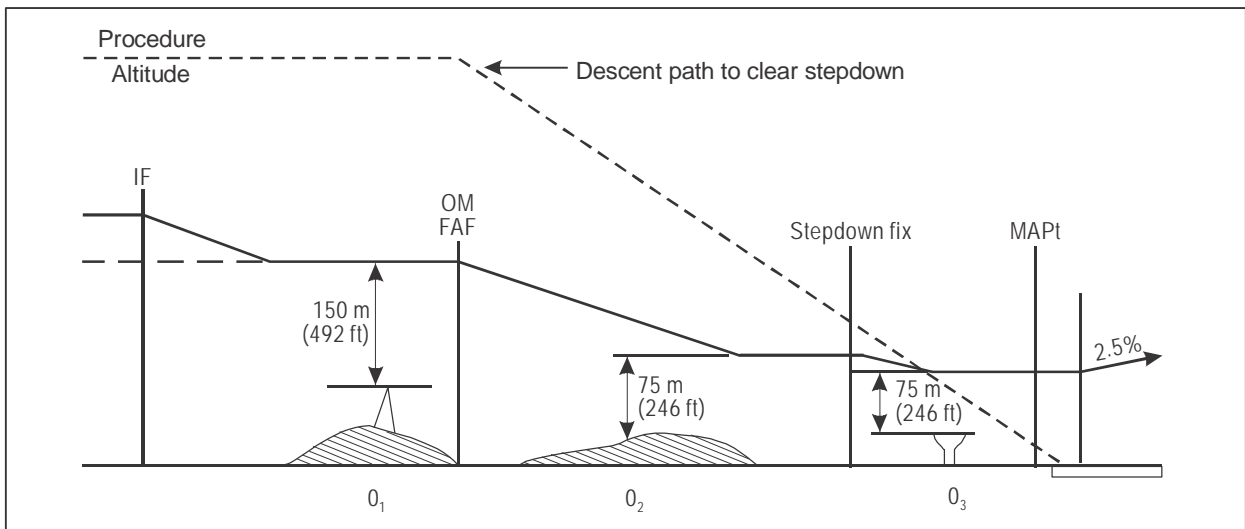

Figure II-2-2-2. Azimuth-only procedure — obstacle clearance and procedure altitude

Chapter 3

VOR OR NDB WITH NO FAF

Note.— A no-FAF instrument approach procedure does not easily support a stable final approach descent profile and therefore may contribute to unstabilized flight profiles. Therefore, the development of approach procedures in this chapter are not encouraged, and shall only be considered when a specific need to accommodate non-RNAV equipped aircraft exists.

3.1 GENERAL

This chapter deals with the specific criteria of procedures based on a VOR or NDB facility located on an aerodrome in which no FAF is established. An on-aerodrome facility is one which is located within 1.9 km (1.0 NM) of the nearest portion of the usable landing surface. These procedures must incorporate a reversal or racetrack procedure. The general criteria in Part I, Sections 1, 2 and 4 apply as amplified or modified herein.

3.2 INITIAL APPROACH SEGMENT

The initial approach fix (IAF) is defined by overheading the navigation facility. The initial approach is a reversal or racetrack procedure.

3.3 INTERMEDIATE SEGMENT

This type of procedure has no intermediate segment. Upon completion of the reversal or racetrack procedure, the aircraft is on final approach.

3.4 FINAL APPROACH SEGMENT

3.4.1 General

The final approach begins where the reversal or racetrack procedure intersects the final approach track inbound.

3.4.2 Alignment

The alignment of the final approach track with the runway centre line determines whether a straight-in or circling approach may be established (see Part I, Section 4, Chapter 5, 5.2, “Alignment”).

3.4.3 Area

3.4.3.1 Figure II-2-3-1 illustrates the final approach primary and secondary areas. The area is longitudinally centred on the final approach track. For VOR or NDB on-aerodrome procedures where there is no FAF a reversal or racetrack procedure must be executed before the final approach and the final approach area shall extend to the far boundary of the area for reversal or racetrack procedure.

3.4.3.2 VOR Area

The final approach area is 3.7 km (2.0 NM) wide at the facility and splays at an angle of 7.8° on either side. A secondary area, comprising 25 per cent of the total width, lies on each side of the primary area, which comprises 50 per cent of the total (see Part I, Section 2, Chapter 1, 1.2, “Areas”).

3.4.3.3 NDB Area

The area is 4.6 km (2.5 NM) wide at the facility and splays at an angle of 10.3° on either side. A secondary area, comprising 25 per cent of the total width lies on each side of the primary area, which comprises 50 per cent of the total (see Part I, Section 2, Chapter 1, 1.2, “Areas”).

3.4.4 Obstacle clearance

3.4.4.1 Straight-in approach

The minimum obstacle clearance in the primary area is 90 m (295 ft). In the secondary area 90 m (295 ft) of obstacle clearance shall be provided at the inner edge, reducing uniformly to zero at the outer edge.

3.4.4.2 Circling approach

3.4.4.2.1 Obstacle clearance in the visual manoeuvring (circling) area shall be as prescribed in Part I, Section 4, Chapter 7, Table I-4-7-3 (see also Part I, Section 4, Chapter 5, 5.4.4, “OCA/H for visual manoeuvring (circling)” for OCA/H calculation).

3.4.4.2.2 A circling approach is not prescribed for helicopters. When the final approach track alignment does not meet the criteria for a straight-in landing, the helicopter must manoeuvre visually to join the FATO axis. The track alignment should ideally be made to the centre of the FATO. In exceptional cases it may be aligned to a point in space.

3.5 DESCENT GRADIENT

The descent gradient relates to the length of time specified for the reversal or racetrack procedure. Criteria in Part I, Section 4, Chapter 3, 3.7.1, “General” apply to the initial segment. Rates of descent in the final approach phase are given in Part I, Section 4, Chapter 5, 5.3, “Descent gradient”.

3.6 USE OF STEPDOWN FIX

The use of a stepdown fix (Part I, Section 2, Chapter 2, 2.7.3) is permitted. Where a stepdown fix is provided then the obstacle clearance may be reduced to 75 m (246 ft) between the stepdown fix and the MAPt. See Figure II-2-3-2.

3.7 MISSED APPROACH POINT (MAPt)

The MAPt is located at the facility or defined by an adequate fix. The missed approach area shall commence at the MAPt.

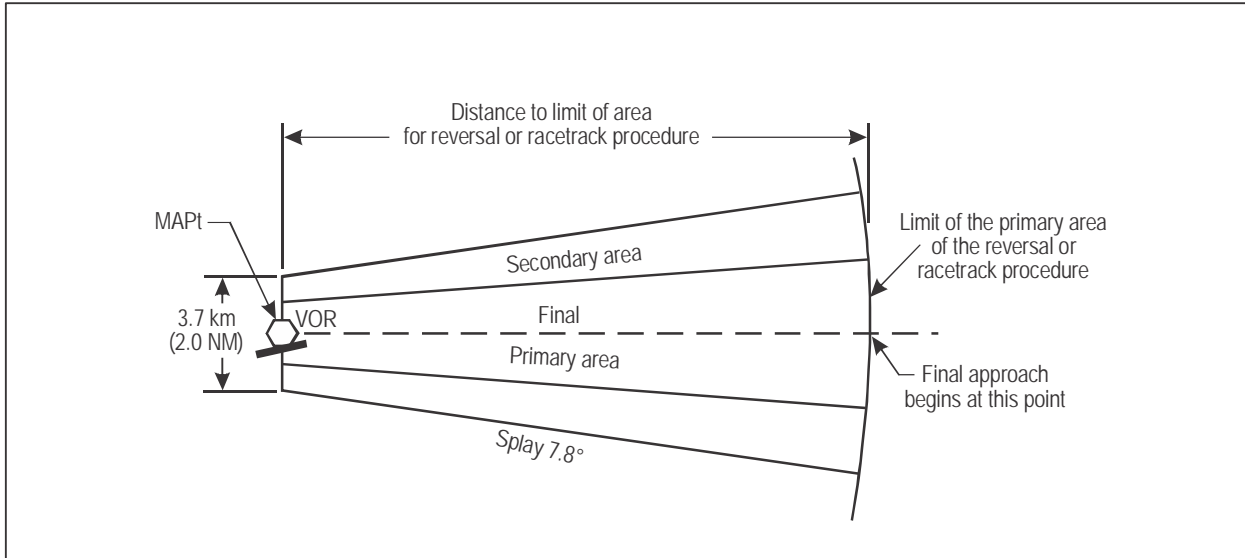

Figure II-2-3-1. Final approach area (VOR)

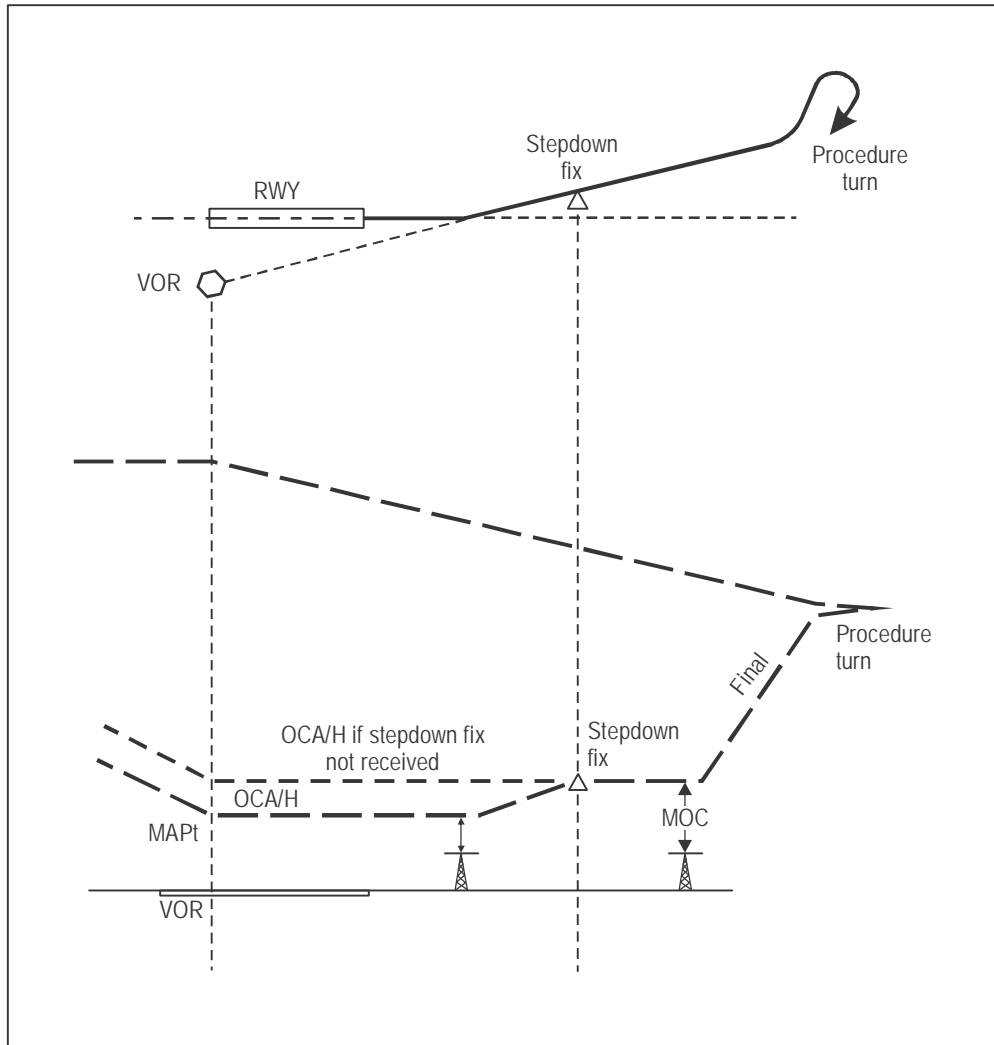

Figure II-2-3-2. Stepdown fix with dual OCA/H

Chapter 4

VOR or NDB with FAF

4.1 GENERAL

This chapter deals with the specific criteria of procedures based on a VOR or an NDB facility in which a FAF is incorporated. The general criteria in Part I, Sections 1, 2 and 4 apply, as amplified or modified herein.

4.2 INITIAL APPROACH SEGMENT

The general criteria in Part I, Section 4, Chapter 3 apply.

4.3 INTERMEDIATE APPROACH SEGMENT

The general criteria in Part I, Section 4, Chapter 4 apply.

4.4 FINAL APPROACH SEGMENT

4.4.1 The final approach may be made either “from” or “toward” the VOR. The final approach segment begins at the FAF and ends at the MAPt. See Figures II-2-4-1, II-2-4-2 and II-2-4-3 for typical approach segments.

4.4.2 Alignment

The alignment of the final approach track with the runway centre line determines whether a straight-in or circling only approach may be established. (See Part I, Section 4, Chapter 5, 5.2, “Alignment”.)

4.4.3 Descent gradient

4.4.3.1 The descent gradient criteria of Part I, Section 4, Chapter 5, 5.3, “Descent gradient” apply.

4.4.3.2 *Profile descent with DME.* Where a DME is suitably located, it may be used to define the distance/height relationship for the descent path angle required to facilitate CDFA technique. This information may be published on the appropriate approach chart, preferably in increments of 2 km (1 NM).

4.4.4 Area

4.4.4.1 The area considered for obstacle clearance in the final approach segment starts at the FAF and ends at the MAPt. It is a portion of a 37 km (20 NM) (NDB: 28 km (15 NM)) long trapezoid which is made up of primary and secondary areas. The area is centred longitudinally on the final approach track. It is 3.7 km (2.0 NM, NDB 4.6 km (2.5 NM)) wide at the facility and splays uniformly at an angle of 7.8° (NDB: 10.3°) either side of the area to 37 km (20 NM) from the VOR (28 km (15 NM) from the NDB). The inner 50 per cent of the area is the primary area, while the outer 25 per cent on each side of the primary area is the secondary area.

4.4.4.2 Final approach may be made to aerodromes which are a maximum of 37 km (20 NM) from the VOR (28 km (15 NM) from the NDB). However, only that portion of the 37 km (20 NM) (NDB: 28 km (15 NM)) trapezoid which falls between the FAF and the MAPt shall be considered as the final approach segment for obstacle clearance purposes. See Figure II-2-4-4.

4.4.4.3 The optimum length of the final approach segment is 9 km (5 NM) (Cat H, 3.7 km (2.0 NM)). The maximum length should not normally be greater than 19 km (10 NM). The minimum length (See Part I, Section 4, Chapter 5, 5.5.1.3) shall provide adequate distance for an aircraft to make the required descent, and to regain track alignment when a turn is required over the FAF. Table I-4-5-1 shall be used to determine the minimum length needed to regain the track after a turn over the FAF.

4.4.4.4 If the turn at the FAF is greater than 10° the final approach area should be widened on the outer side of the turn as specified in Part I, Section 4, Chapter 6, 6.4.6.3.3, “TP marked by a facility (NDB or VOR)”.

4.4.5 Station providing track guidance

When more than one facility is on the final approach track, the facility to be used for track guidance for final approach shall be clearly identified.

4.4.6 Obstacle clearance

4.4.6.1 *Straight-in approach.* The minimum obstacle clearance in the primary area is 75 m (246 ft). In the secondary area 75 m (246 ft) of clearance shall be provided over all obstacles at the inner edge, tapering uniformly to zero at the outer edge. See Part I, Section 2, Chapter 1, 1.7, “Increased altitudes/heights for mountainous areas”.

4.4.6.2 *Circling approach.* Obstacle clearance in the visual manoeuvring area shall be as described in Part I, Section 4, Chapter 7, “Visual manoeuvring (circling) area”.

4.5 MISSED APPROACH POINT (MAPt)

4.5.1 Off-aerodrome facility — Straight-in approach

The MAPt is located at a point on the final approach track which is not farther from the FAF than the threshold. See Figure II-2-4-4.

4.5.2 Off-aerodrome facility — Circling approach

The MAPt is located at a point on the final approach track which is not farther from the FAF than the first usable portion of the landing surface.

4.5.3 On-aerodrome facility

The MAPt is located at a point on the final approach track which is not farther from the FAF than the facility.

4.6 PROMULGATION

The general criteria in Part I, Section 2, Chapter 1, 1.11, “Promulgation” apply. The instrument approach chart for a VOR approach procedure shall be identified by the title VOR RWY XX. If a DME is required it shall be indicated in a note on the chart. When a DME has been used to obtain lower minima, no additional note is required as this shall be shown in the minima boxes. If a DME is used to define the distance/height relationship for a profile descent, the information shall be published on the chart, preferably in increments of 2 km (1 NM). If separate approach charts are published for different aircraft categories, the Duplicate Procedure Title convention shall be applied, with the approach having the lowest minima being identified as ILS RWY XX, LOC RWY XX, VOR Z RWY XX, NDB Y RWY XX, etc. A note shall be included on the chart detailing the applicable aircraft categories.

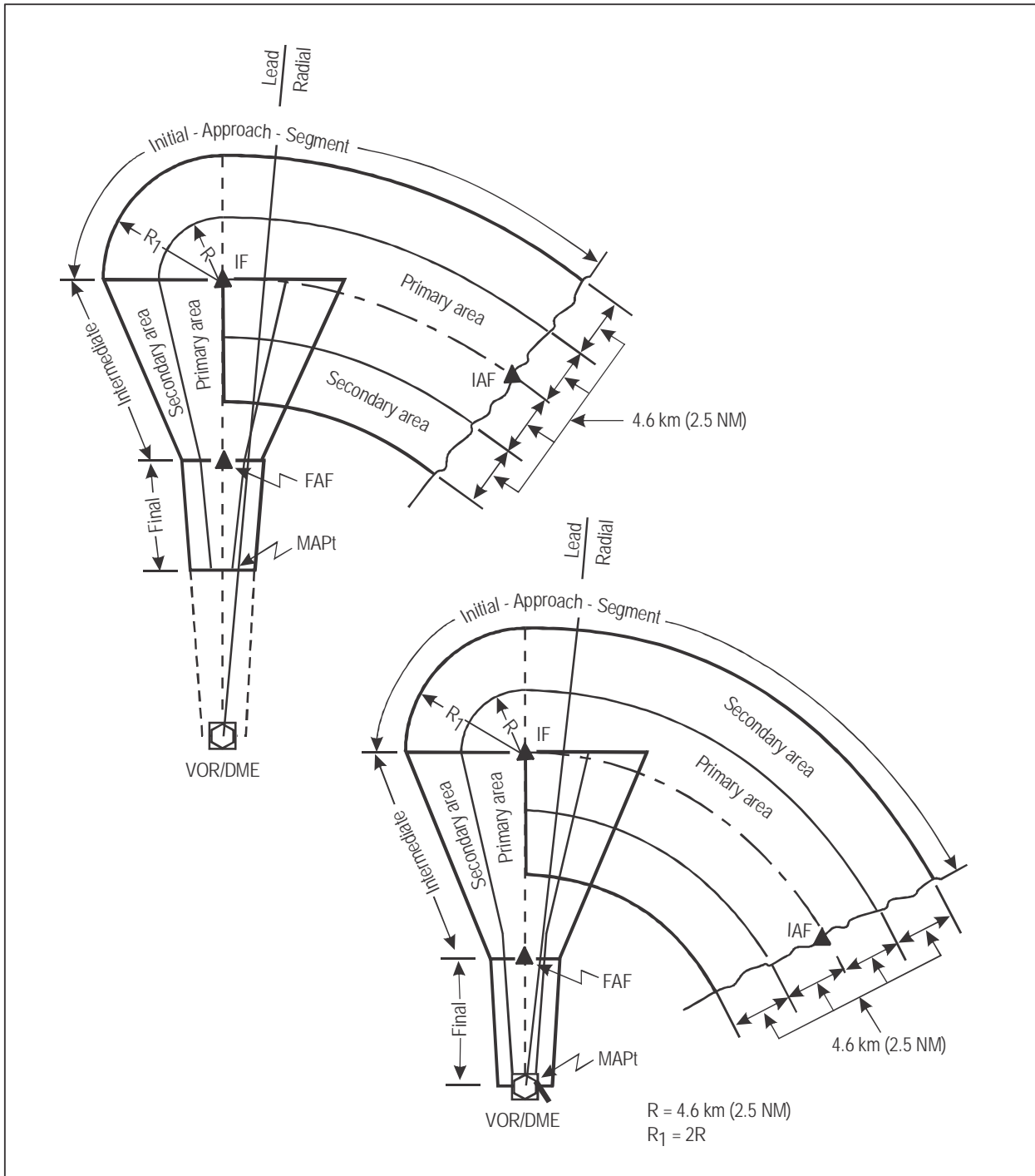

Figure II-2-4-1. Typical approach segments (with DME arcs)

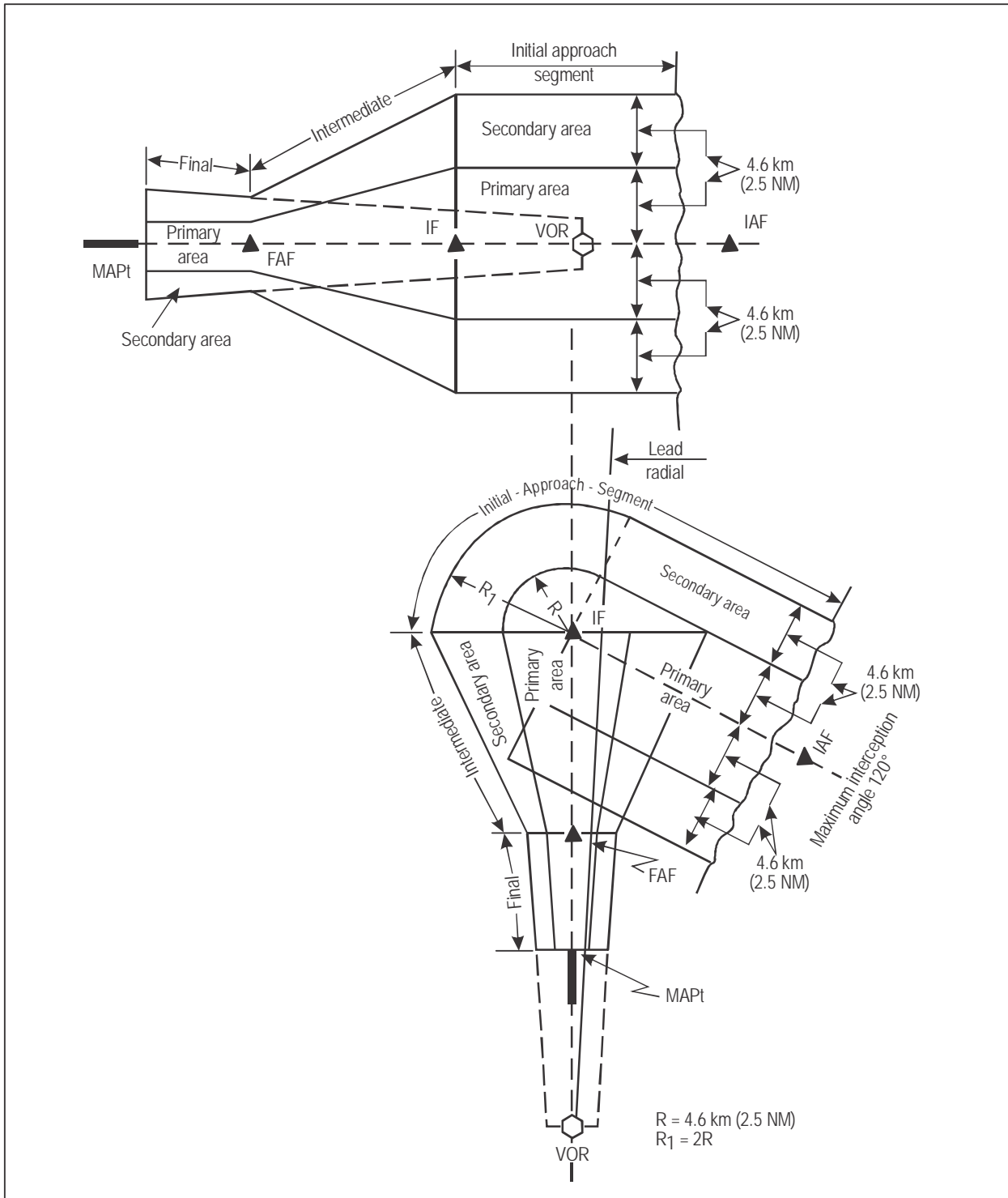

Figure II-2-4-2. Typical approach segments (straight and >90° turn)

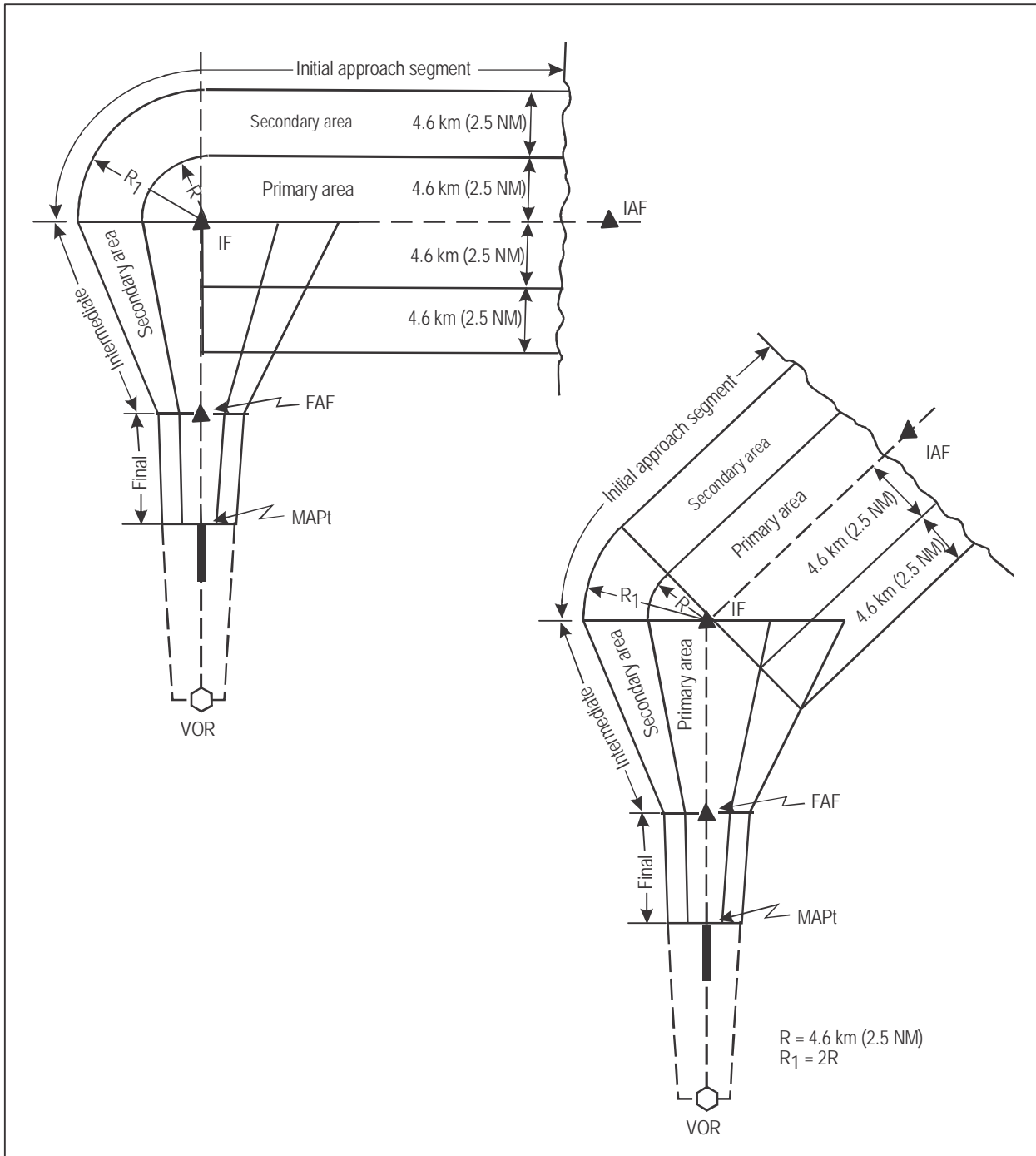

Figure II-2-4-3. Typical approach segment (45° and 90° turns)

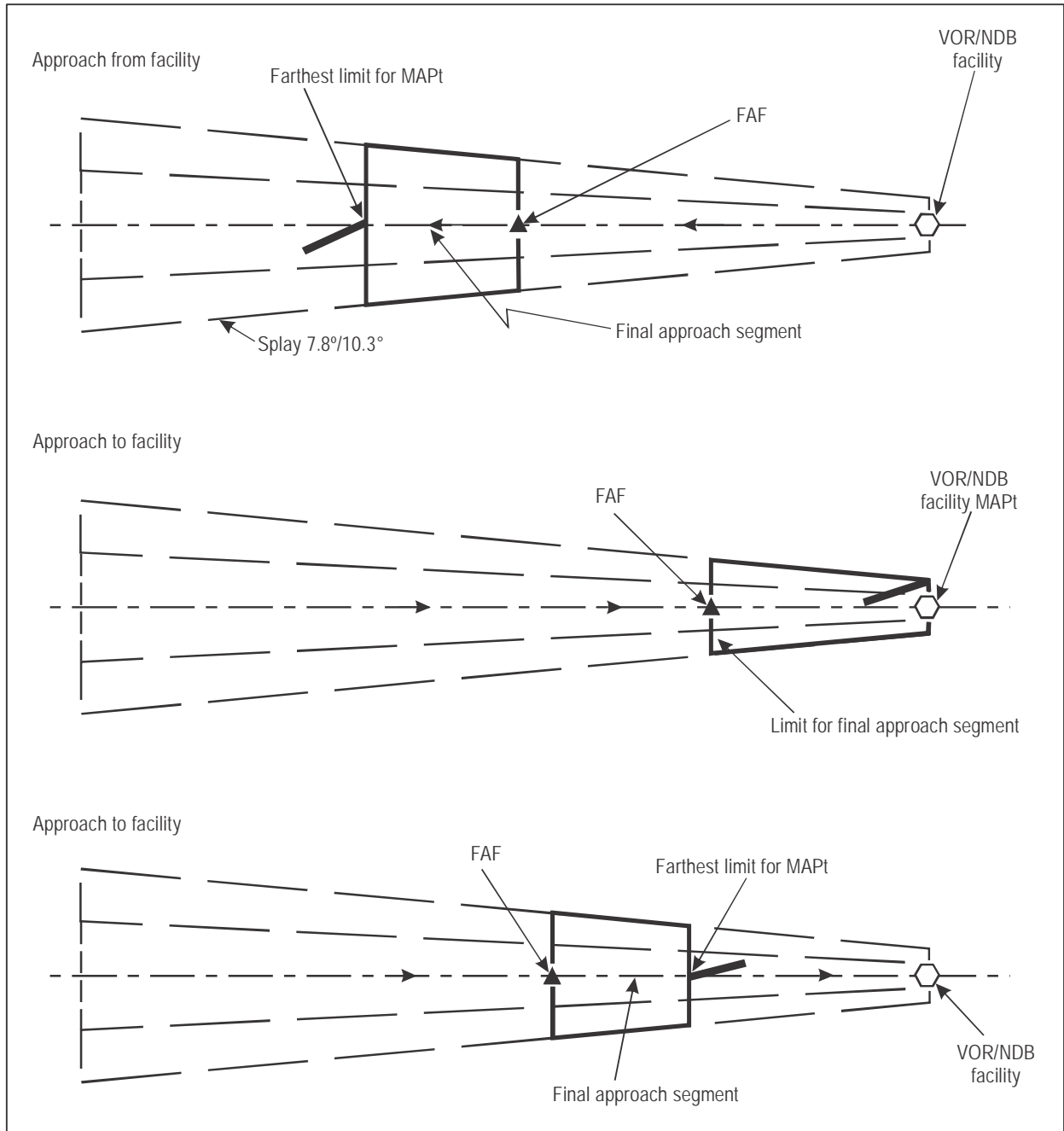

Figure II-2-4.4. Final approach segment (VOR/NDB)

Chapter 5

DF

5.1 GENERAL

This chapter deals with the specifics of procedures based on a very high frequency direction-finding (VDF) station located on or close to an aerodrome, that is, within 2 km (1 NM) of the nearest portion of the usable landing surface. These procedures must incorporate a base turn (see Part I, Section 4, Chapter 3, 3.5.4, “Types of reversal procedures”). The general criteria in Part I, Sections 1, 2 and 4 apply, as amplified or modified herein.

5.2 DESCENT GRADIENT

The rates of descent in the initial and final approach segments shall be as specified in Part I, Section 4, Chapter 3, Table I-4-3-1.

5.3 INITIAL APPROACH SEGMENT

5.3.1 General

5.3.1.1 The initial approach fix (IAF) is received by overheading the navigation facility. The initial approach is a base turn.

5.3.1.2 *Time of flight outbound.* The time of flight outbound should be limited to the period sufficient to ensure that the base turn is completed at a distance which permits descent from the base turn altitude/height to the MDA/H specified.

Note.— The angle between the outbound and inbound tracks is determined by the formula $36/t$ for Category A and B and $54/t$ for Category C, D, and E aircraft, where t is the outbound specified time expressed in minutes. The outbound track should be sufficient to ensure that at least 2 minutes are allowed inbound to permit proper establishment of track.

5.3.2 Area

The area is a sector of a circle centred on the navigation facility, symmetrical about the bisector of the inbound and outbound tracks, with an angle of:

- a) $20^\circ + 36/t$ for Category A and B; and
- b) $20^\circ + 54/t$ for Category C, D and E aircraft,

having a radius D for all aircraft.

D is described by the following equation:

$$D = \left(\frac{V}{60} + 1.9 \right) t + 2.8 \text{ km}$$

$$[D = \left(\frac{V}{60} + 1.0 \right) t + 1.5 \text{ NM}]$$

where: D = the radius in km [NM]

V = true aircraft speed in km/h [kt]

t = outbound time in minutes.

This sector shall be extended in all directions by a margin of 3.7 km (2.0 NM). (See Figure II-2-5-1.)

5.3.3 Obstacle clearance in the initial approach

The obstacle clearance in the initial approach area shall be 300 m (984 ft).

5.4 INTERMEDIATE SEGMENT

This type of procedure has no intermediate segment. Upon completion of the base turn, the aircraft is on final approach.

5.5 FINAL APPROACH SEGMENT

5.5.1 General

The final approach begins where the base turn intersects the final approach track inbound.

5.5.2 Alignment

5.5.2.1 The alignment of the final approach track with respect to:

- a) the facility;
- b) the runway centre line; and
- c) the runway threshold,

will determine whether a straight-in or circling approach may be established. (See Part I, Section 4, Chapter 5, 5.2, “Alignment”.)

5.5.2.2 *Alignment — Helicopter procedures.* When the final approach track alignment of a helicopter procedure does not meet the criteria for a straight-in landing, the helicopter must be manoeuvred visually to join the FATO axis. Track alignment should ideally be made to the centre of the FATO. In exceptional cases it may be aligned to a point in space.

5.5.3 Area

Figure II-2-5-2 illustrates the final approach area. There are no secondary areas. The area is symmetrical about the final approach track. It is 5.6 km (3.0 NM) wide at the facility and expands at an angle of 10° either side. It extends to the far boundary of the base turn area.

5.5.4 Obstacle clearance in the final approach

5.5.4.1 *Straight-in.* The minimum obstacle clearance in the final approach area is 90 m (295 ft). See Part I, Section 2, Chapter 1, 1.7, “Increased altitudes/heights for mountainous areas”.

5.5.4.2 *Visual manoeuvring (circling).* *In addition to the minimum requirement specified in 5.5.4.1 above, obstacle clearance in the visual manoeuvring (circling) area shall be as prescribed in Part I, Section 4, Chapter 7, “Visual manoeuvring (circling) area”.*

5.6 MISSED APPROACH SEGMENT

The MAPt is located at the facility. The missed approach area shall commence at the MAPt. The longitudinal tolerance of the MAPt area shall be calculated as in Part I, Section 4, Chapter 6, “Missed approach segment” and for the purpose of this calculation, the FAF tolerance error shall be ± 1.9 km (1.0 NM).

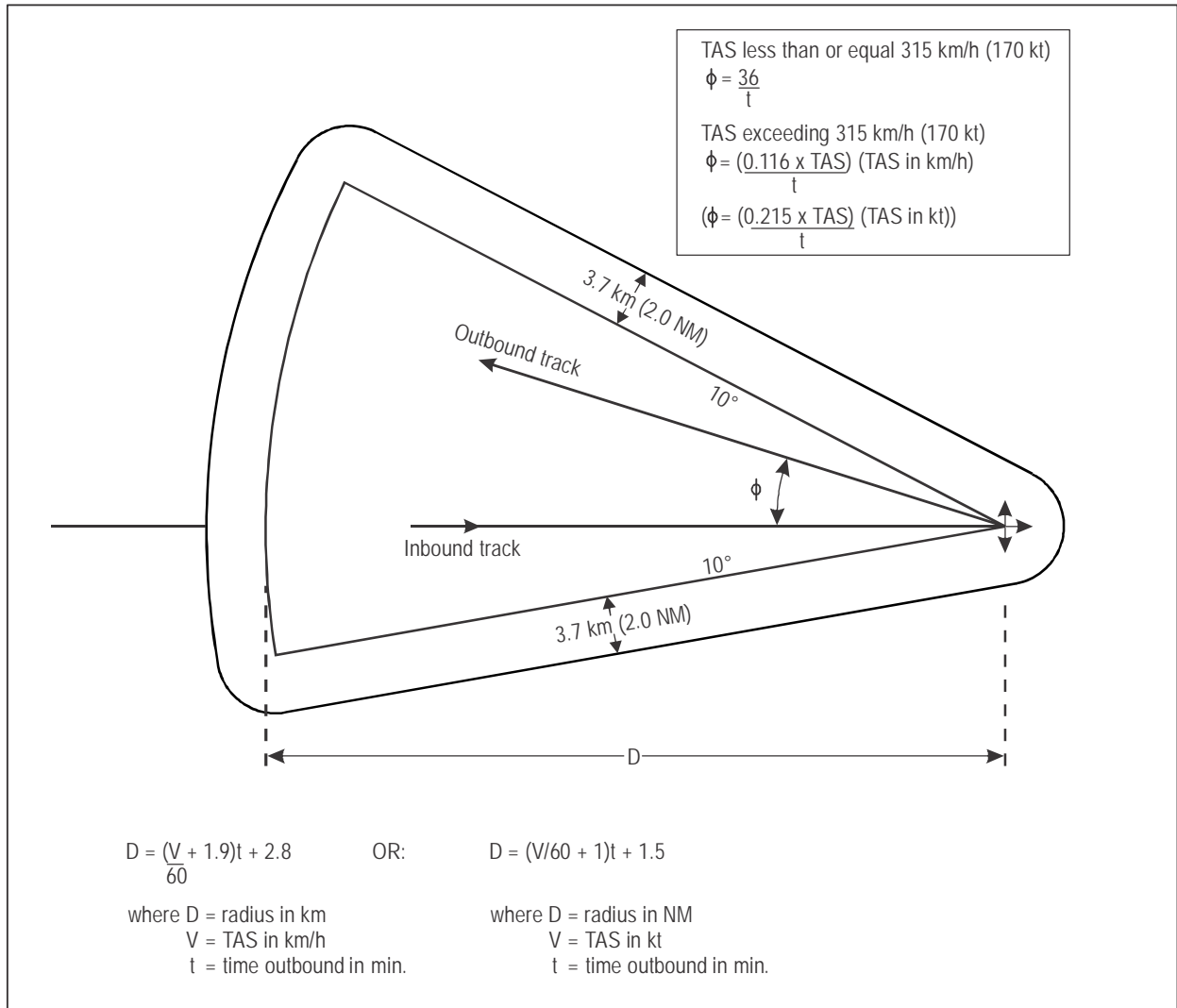

Figure II-2-5-1. D/F facility (on or close to an aerodrome)

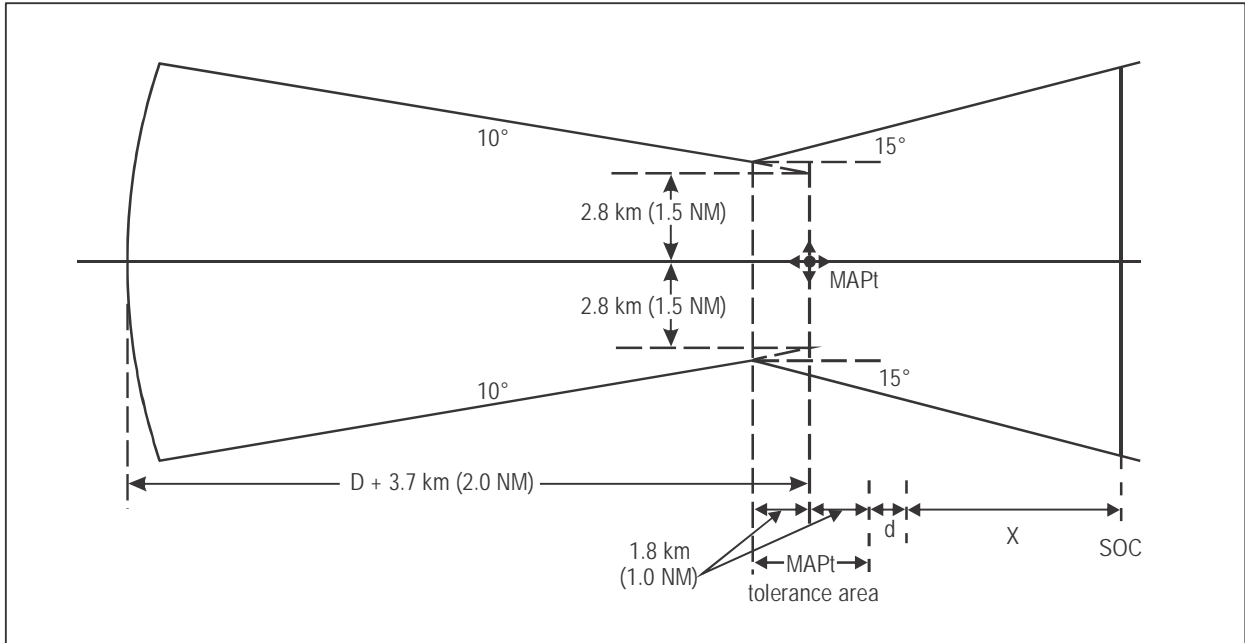

Figure II-2-5-2. Final approach area

Chapter 6

SRE

6.1 GENERAL

Surveillance radar may be used to provide primary navigation guidance within the operational coverage of the radar. Straight-in and circling approaches may be authorized to aerodromes where the quality of radar coverage and target resolution are adequate to support the procedure (see Figure II-2-6-1).

Note.— Detailed procedures regarding the use of primary radar in the approach control service are set forth in the PANS-ATM, Doc 4444, Procedures for Air Navigation Services — Air Traffic Management.

6.2 INITIAL APPROACH SEGMENT

6.2.1 General

The initial segment begins at the initial approach fix (IAF), which is defined as the position at which radar contact with the aircraft for the purpose of executing an approach has been established. It ends at the IF. In this segment, radar vectoring may be provided along predetermined tracks (6.2.2) or on a tactical basis (6.2.3).

Note.— See the PANS-ATM, Chapter 12, for identification procedures.

6.2.2 Procedures based on predetermined tracks

The establishment of radar procedure patterns requires the following:

- a) *Area.* The area width on each side of the predetermined radar track is 9.3 km (5.0 NM). The area has no specific maximum or minimum length; however, it should be long enough to permit the altitude loss required by the procedure at the authorized descent gradient.

Note.— The width of the area may be reduced to 5.6 km (3.0 NM) on each side of the track within 37 km (20 NM) of the radar antenna depending upon the accuracy of the radar equipment, as determined by the appropriate authority. See the PANS-ATM, Chapter 12.

- b) *Obstacle clearance.* A minimum of 300 m (984 ft) of clearance shall be provided over all obstacles in the initial approach area. Clearance over a prominent obstacle, if displayed as a permanent echo on the radar scope may be discontinued after the aircraft has been observed to pass the obstacle.

6.2.3 Procedures based on tactical vectoring

The following restrictions apply:

- a) *Area*. The area considered for obstacle clearance shall be the entire area within the operational coverage of the radar. This area may be subdivided to gain relief from obstacles which are clear of the area in which flight is to be conducted. There is no prescribed limit on the size, shape or orientation of these subdivisions; however, in all cases the boundary of the subdivision must be located at a distance not less than 5.6 km (3 NM) from an obstacle which is to be avoided or from another area over which flights are prohibited. The subdivision boundaries are depicted on video map and designed to emphasize simplicity and safety in radar ATC application. (See note under 6.1.)
- b) *Obstacle clearance*. A minimum of 300 m (984 ft) of clearance shall be provided over all obstacles within the area or approximate subdivision where subdivisions have been established. Levels established for use shall also provide 300 m (984 ft) of clearance over all obstacles within 5.6 km (3.0 NM) of the area boundary when up to 37 km (20 NM) from the radar antenna, or within 9.3 km (5.0 NM) of the boundary at distances greater than 37 km (20 NM) from the antenna.
- c) *Minimum vectoring altitudes*. Minimum vectoring altitudes shall be corrected for cold temperature. The cold temperature shall be based on seasonal or annual minimum temperature records. See PANS-OPS, Volume I, Part III, Section 1, Chapter 4, Tables III-1-4-1 a) and b).

6.2.4 Descent gradients

The optimum descent gradient in the initial approach is 4.0 per cent (Cat H, 6.5 per cent). Where a higher descent rate is necessary, the maximum permissible gradient is 8.0 per cent (Cat H, 10 per cent).

6.3 INTERMEDIATE APPROACH SEGMENT

6.3.1 General

The intermediate segment begins at the radar fix where the initial approach track intersects the intermediate approach track. The point of intersection is the IF. The intermediate segment extends along the intermediate track inbound to the point where it intersects the final approach track. This point is the FAF.

6.3.2 Alignment

The intermediate track shall not differ from the final approach track by more than 30°.

6.3.3 Area

The width of the intermediate area is determined by the width of the initial area at the IF, tapering to the width of the final area at the FAF. The length of the intermediate segment shall not exceed 28 km (15 NM) (Cat H, 9.3 km (5 NM)). The optimum length of the intermediate segment is 9 km (5 NM) (Cat H, 3.7 km (2.0 NM)). The minimum length depends upon the angle at which it is intercepted by the initial approach track and is specified in Table II-2-6-1. However, these minimum values should be used *only* if usable airspace is restricted. The maximum angle of interception shall be 90°.

6.3.4 Obstacle clearance

A minimum of 150 m (500 ft) of clearance shall be provided over all obstacles in the intermediate area.

6.3.5 Descent gradient

Because the intermediate segment is used to prepare the aircraft speed and configuration for entry into the final approach segment, the gradient should be flat (Cat H, 6.5 per cent). Where a higher gradient is necessary the maximum permissible gradient is 5.0 per cent (Cat H, 10 per cent).

6.4 FINAL APPROACH SEGMENT

6.4.1 General

The final approach segment begins at the FAF, which is a radar fix on the final approach track.

6.4.2 Alignment

For straight-in approaches, the final approach track shall coincide with the extended runway centre line. For circling approaches, the final approach track shall be aligned to cross the aerodrome manoeuvring area or to intercept the downwind leg of the visual manoeuvring (circling) pattern.

6.4.3 Area

The area to be considered for obstacle clearance begins at the FAF and ends at the MAPt or the runway threshold whichever occurs last and is centred on the final approach track (see Figure II-2-6-2). The minimum length of the final approach area shall be 6 km (3 NM) (Cat H, 1.9 km (1 NM)). The length shall be established by taking account of the permissible descent gradient. See 6.4.5. The maximum length should not exceed 11 km (6 NM). Where a turn is required over the FAF, Table II-2-4-1 of Chapter 4 applies. The width of the area is proportional to the distance from the radar antenna, according to the following formula:

$$W/2 = (1.9 + 0.1 D) \text{ km}$$

$$[W/2 = (1.0 + 0.1 D) \text{ NM}]$$

where: W = width in km [NM]

D = distance from antenna to track in km [NM]

Maximum value for D is 37 km (20 NM) subject to the accuracy of the radar equipment as determined by the appropriate authority.

6.4.4 Obstacle clearance

The minimum obstacle clearance is 75 m (246 ft).

6.4.5 Descent gradient

The general criteria of Part I, Section 4, Chapter 5, 5.3 apply.

6.4.6 Computation of altitudes/heights

Altitudes/heights through which the aircraft should pass to maintain the required descent path should be computed for each 2 or 1 km (1 or 1/2 NM) from touchdown assuming a 15 m (50 ft) height at the runway threshold. The resultant altitudes/heights should be rounded out to whole 10 m or 100 ft increments, except for distances less than 4 km (2 NM) from touchdown, where they should be rounded up to the next whole 10 m or 10 ft increment as appropriate. Precomputed altitudes/heights should be available to the radar controller and published in aeronautical information publications.

6.5 MISSED APPROACH SEGMENT

A surveillance radar approach shall be terminated 4 km (2 NM) before the threshold, except that when approved by the appropriate authority, it may be continued to a point not later than the runway threshold when the accuracy of the radar permits. The missed approach point (MAPt) is located at the point where the radar approach terminates. See Figure II-2-6-3 and Part I, Section 4, Chapter 6 for missed approach criteria.

Table II-2-6-1. Minimum length of intermediate segment

<i>Intercept angle with localizer (degrees)</i>	<i>Minimum distance between localizer and glide path interceptions</i>	
	Cat A to E	Cat H
0 – 15	2.8 km (1.5 NM)	2.8 km (1.5 NM)
16 – 30	3.7 km (2.0 NM)	3.7 km (2.0 NM)
31 – 60	4.6 km (2.5 NM)	3.7 km (2.0 NM)
61 – 90	5.6 km (3.0 NM)	3.7 km (2.0 NM)

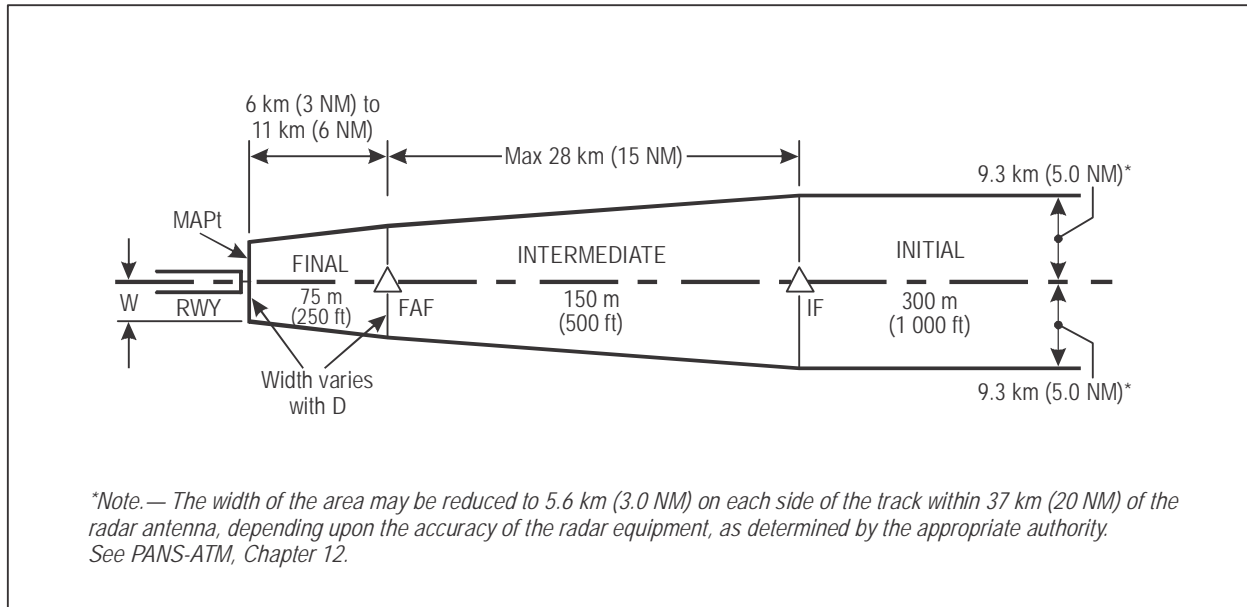

Figure II-2-6-1. Surveillance radar approach segments

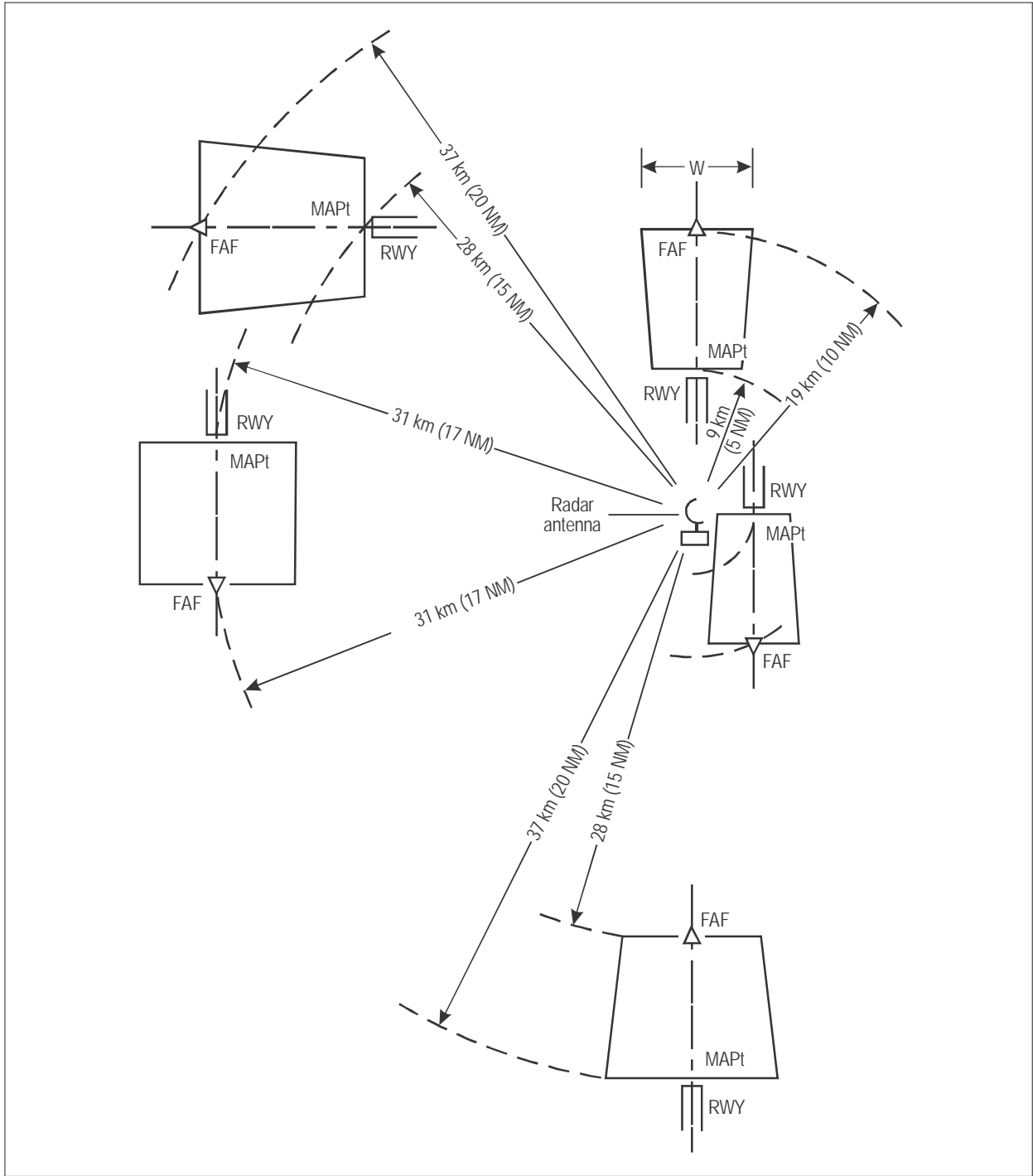

Figure II-2-6-2. Examples of surveillance radar final approach

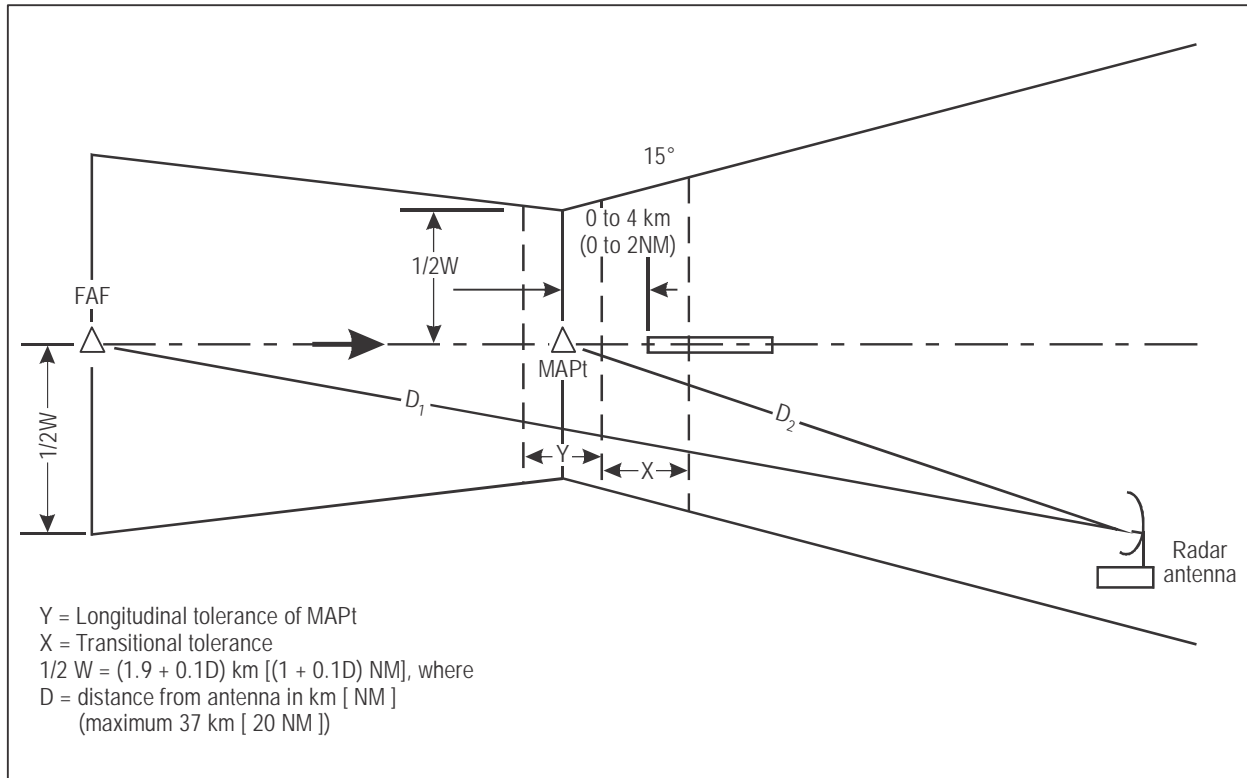

Figure II-2-6-3. Surveillance radar approach

Section 3
EN-ROUTE CRITERIA

Chapter 1

VOR AND NDB ROUTES

1.1 GENERAL

1.1.1 Scope

The areas associated with en-route criteria extend over very large surfaces; in some regions, the number of obstacles to consider is very high. Moreover, at crossing points, it may happen that several possibilities are offered to continue the flight, which can raise difficulties for the protection of all possible turns. For these reasons, two methods have been developed:

- a) a simplified method, presented in this chapter and retained as the standard method; and
- b) a refined method, described in Appendix A, which can be used when the simplified method is too constraining.

1.1.2 Segments

A route is generally composed of several segments. Each segment begins and ends at a designated fix.

1.2 OBSTACLE CLEARANCE AREAS

1.2.1 General

This section contains the description of the areas used for en-route obstacle clearance purposes.

1.2.2 Straight segment

The obstacle clearance areas consist of a primary area and a buffer area. The width of the primary and buffer areas is constant from their width abeam the facility until a specified distance from the system giving track. From this point, the areas splay as a function of the angular tolerance lines of the applicable facility, as described below in 1.4.2.3, “Angular limits”. (See also Figure II-3-1-2 and Figure II-3-1-3.)

1.2.3 Area without track guidance

When track guidance is not provided, for example outside the coverage of navigation facilities along the route, the primary area splays each side at an angle of 15° from its width at the last point where track guidance was available. The width of the buffer area is progressively reduced to zero, ending in an area without track guidance where the full MOC is applied (see Figure II-3-1-8).

1.2.4 Maximum area width

There is no maximum area width for routes within the coverage of the facilities defining the route. Outside coverage of the facilities defining the route, the area splays each side at 15°, as specified above in 1.2.3, “Area without track guidance”.

1.2.5 Turn area

The obstacle clearance areas consist of a primary area; no buffer areas are applied. Turn area construction is described in 1.4, “Construction of areas for VOR and NDB routes”.

1.3 OBSTACLE CLEARANCE

1.3.1 Minimum obstacle clearance (MOC)

1.3.1.1 The minimum obstacle clearance value to be applied in the primary area for the en-route phase of an IFR flight is 300 m (984 ft). (See 1.3.2 for MOC in mountainous areas). In the buffer area, the minimum obstacle clearance is equal to half the value of the primary area MOC (see Figure II-3-1-1).

1.3.1.2 A minimum obstacle clearance altitude (MOCA) is determined and published for each segment of the route. The MOCA provides the required MOC above obstacles contained inside the obstacle clearance areas. Charting accuracies shall be taken into account when establishing minimum altitudes by adding both a vertical and a horizontal tolerance to the depicted objects on the chart, as specified in PANS-OPS, Volume II, Part I, Section 2, Chapter 1, 1.7, “Increased altitude/height for mountainous areas”.

1.3.2 MOC in mountainous areas

1.3.2.1 In mountainous areas, the MOC shall be increased, depending on variation in terrain elevation as shown in the table below. The MOC in the buffer area is half the value of the primary area MOC (see Figure II-3-1-1).

<i>Elevation</i>	<i>MOC</i>
Between 900 m (3 000 ft) and 1 500 m (5 000 ft)	450 m (1 476 ft)
Greater than 1 500 m (5 000 ft)	600 m (1 969 ft)

1.3.2.2 Mountainous areas shall be identified by the State and promulgated in the State Aeronautical Information Publication (AIP), section GEN 3.3.5, “Minimum flight altitude”.

1.3.3 MOC for turns

The full MOC applies over the total width of the turning area as shown in Figure II-3-1-5. There is no buffer area.

1.3.4 MOC when no track guidance provided

When track guidance is not provided, for example outside the coverage of navigation facilities along the route, the primary area splays each side at an angle of 15° from its width at the last point where track guidance was available. The width of the buffer area is progressively reduced to zero, ending in an area without track guidance where the full MOC is applied (see Figure II-3-1-8).

1.4 CONSTRUCTION OF AREAS FOR VOR AND NDB ROUTES

1.4.1 General

This section contains methods for calculating the areas used for en-route obstacle clearance purposes. The statistical derivation of these calculations, which are based on a root sum square method of the navigation system use accuracy, appears in Appendix B.

1.4.2 Straight areas

1.4.2.1 *Area descriptions.* The obstacle clearance areas consist of a primary area and two lateral buffer areas on each side.

1.4.2.2 *Width abeam the facility.* Abeam the facility, the total area has a constant width of 18.5 km (10.0 NM), which is comprised of the primary area and a buffer area. The primary area maintains a constant width of 9.3 km (5.0 NM) on either side of the nominal track. The buffer area also maintains a constant width of 9.3 km (5.0 NM) on either side of the primary area.

1.4.2.3 *Angular limits.* When the distance from the facility is greater than:

- a) 92.3 km (49.8 NM) for VOR; and
- b) 60 km (32 NM) for NDB,

the areas diverge, following the angular tolerance lines of their respective facilities (See Table II-3-1-1).

1.4.2.4 *Width after the point of divergence.* After the limiting distance stated in 1.4.2.3, “Angular limits”, the width of the primary area is increased by the angle of splay. The buffer area is determined by the angle of splay plus an additional fixed width on the outside of the buffer area, parallel to its edge (see Figures II-3-1-2 and II-3-1-3). This width is:

- a) 3.7 km (2.0 NM) for VOR; and
- b) 4.6 km (2.5 NM) for NDB.

1.4.2.5 *Longitudinal limits.* The longitudinal limits of the area associated with a straight segment are determined as follows:

- a) the earliest limit of the area is a half circle, centred on the first fix and tangent to the lateral limits of the total area; and
- b) the latest limit of the area is a half circle, centred on the second fix and tangent to the lateral limits of the total area.

1.4.2.6 *Combination of VOR and NDB criteria.* In case of a straight segment based on a VOR at one end and an NDB at the other end, the area is designed as shown in Figure II-3-1-4.

1.4.2.7 *Offset change-over point (COP).* If the change-over point between two facilities is offset due to facility performance problems the system accuracy limits must be drawn from the farthest facility to a point abeam the COP and then joined by lines drawn directly from the nearer facility, which in this case have no specific angles (see Figure II-3-1-7). The COP will be published.

1.4.3 Protection areas associated with turns

1.4.3.1 Turns can be executed overhead a facility or at a fix.

1.4.3.2 *Fix or facility tolerances.*

- a) 4.5° (7.9 %) for VOR angular intersecting tolerance.
- b) 6.2° (10.9 %) for NDB angular intersecting tolerance.
- c) If available, DME can be used as a turning point fix. For DME accuracy values, see Part I, Section 2, Chapter 2, 2.4.4, “DME”.
- d) Facility tolerances — See Part I, Section 2, Chapter 2, 2.5, “Fix tolerance overheading a station”.

1.4.3.3 *Turn parameters.* The following turn parameters are applied:

- a) altitude — an altitude at or above which the area is designed;
- b) temperature — ISA for the specified altitude plus 15° C;
- c) indicated airspeed — 585 km/h (315 kt);
- d) wind — omnidirectional for the altitude h , $w = (12 h + 87)$ km/h, where h is in kilometres, [$w = (2 h + 47)$ kt, where h is in thousands of feet];
- e) average achieved bank angle: 15°;
- f) maximum pilot reaction time: 10 s;
- g) bank establishment time: 5 s; and
- h) turn anticipation distance: $r \cdot \tan(\alpha/2)$, where α is the angle of the course change.

1.4.3.4 *Turn area construction.* Turn area construction (see Figure II 3-1-5) is comprised of the following four steps:

- a) *Start of turn area.* The turn area starts at line K-K. Line K-K is perpendicular to the nominal track and is located at a distance of:
 - 1) $r \cdot \tan(\alpha/2)$, plus
 - 2) the fix tolerance before the nominal fix or facility

where: α = angle of course change

r = radius of turn

b) *Outer edge of the turn.* The outer edge of the turn area is composed of:

- 1) a straight extension of the outer edge of the segment before the turn;
- 2) the arc of a circle having a radius of T, which is centred on the turning point (nominal fix or facility); and
- 3) the tangent of the arc of this circle which makes an angle of 30° with the following segment.

The value of T is described by the following equation:

$$T = SA + 2*r + E_{165^\circ}$$

where: r = radius of turn

E_{165° = wind effect to account for 120° course change plus 30° convergence angle plus 15° drift

SA = area semi-width

This method is based on the assumption that the size of the tolerance associated with the turn point is included in the area corresponding to a straight segment.

Note 1.— Use the highest minimum altitude of all the segments intersecting at the turning point.

Note 2.— Maximum turn angle is 120° .

Note 3.— A constant wind effect (E_{165°) needs to be applied for all turn angles.

Example calculation for an altitude of 4 500 m. Given the turn parameters as stated in 1.4.3.3, “Turn parameters” and area semi-width of 18.5 km, it follows that:

the radius of turn (r) = 16.77

wind effect (E_{165°) = 9.00

$T = 18.5 + 33.54 + 9.00 = 61.04$ km

- c) *Inner edge of the turn.* From point K of the turn, draw a line making an angle of $\alpha/2$ with the nominal track in segment 2 (the segment following the turn). This line ends where it intersects the edge of segment 2.
- d) *End of turn area.* The arc as described under (2) also denotes the end of the turn area.

1.4.3.5 *Bidirectional routes.* The method of construction of the turn area assumes a direction of flight. When the route is to be flown in both directions, it is necessary to construct both turn areas to account for both directions of flight and to apply the minimum obstacle clearance over the whole combined turn area (see Figure II-3-1-6).

1.5 MINIMUM EN-ROUTE ALTITUDE (MEA)

A MEA is determined in coordination with ATS and published for each segment of the route. The MEA is the greatest of:

- the MOCA;
- the minimum altitude for proper reception of the relevant facilities;
- the minimum altitude for proper reception of ATS communications;
- the minimum altitude that complies with the ATS structure.

For planning purposes, in order to determine the minimum altitude for proper reception of the relevant facilities, the following formula can be used.

$$D = 4.13 \sqrt{H} \text{ where distance (D) is in km and the minimum height (H) is in meters}$$

$$D = 1.23 \sqrt{H} \text{ where D is in NM and H is in feet}$$

Note.— The formulae given may be optimistic where high terrain exists in the area of the facility or en route.

1.6 PROMULGATION

1.6.1 *Minimum altitude.* The minimum obstacle clearance altitude (MOCA) and the minimum en-route altitude (MEA) are determined and published for each segment of the route.

1.6.2 Mountainous areas

Mountainous areas shall be identified by the State and promulgated in the State Aeronautical Information Publication (AIP), section GEN 3.3.5, “Minimum flight altitude”.

1.6.3 Offset change-over point (COP)

If the change-over point between two facilities is offset due to facility performance problems the system accuracy limits must be drawn from the farthest facility to a point abeam the COP and then joined by lines drawn directly from the nearer facility, which in this case have no specific angles (see Figure II-3-1-7). The COP will be published.

Table II-3-1-1. Primary and Buffer area splay

	<i>Primary area splay</i>	<i>Buffer area splay</i>
VOR	5.7° (10%)	9.1° (15.86%)
NDB	7.95° (14%)	13.0° (23%)

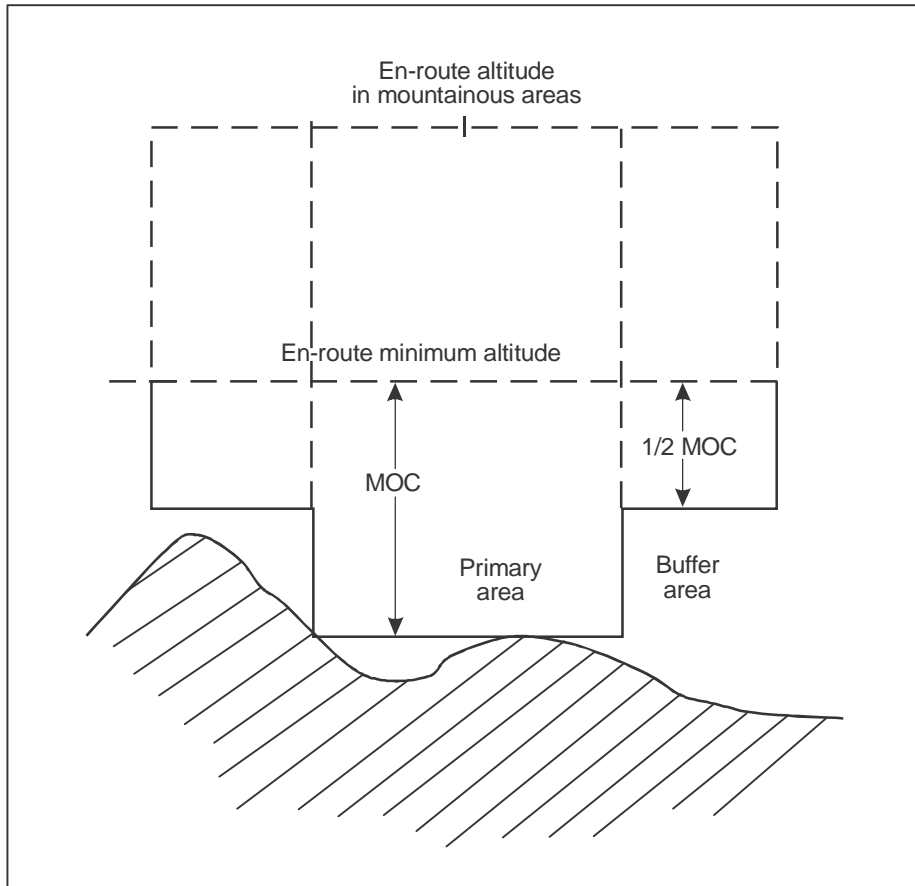

Figure II-3-1-1. En-route MOC — Primary and buffer areas

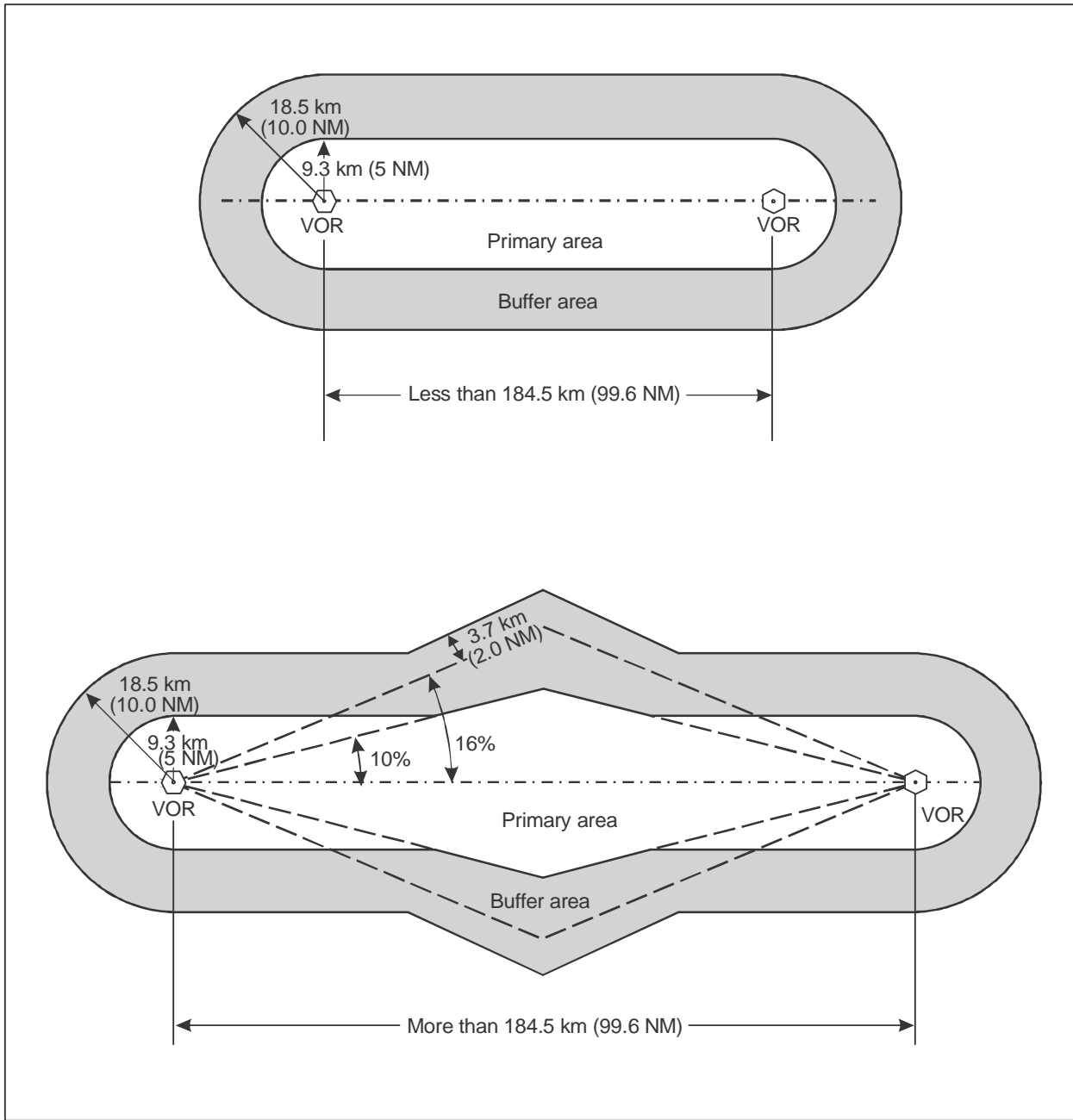

Figure II-3-1-2. Obstacle clearance areas for VOR en-route navigation. Straight segment

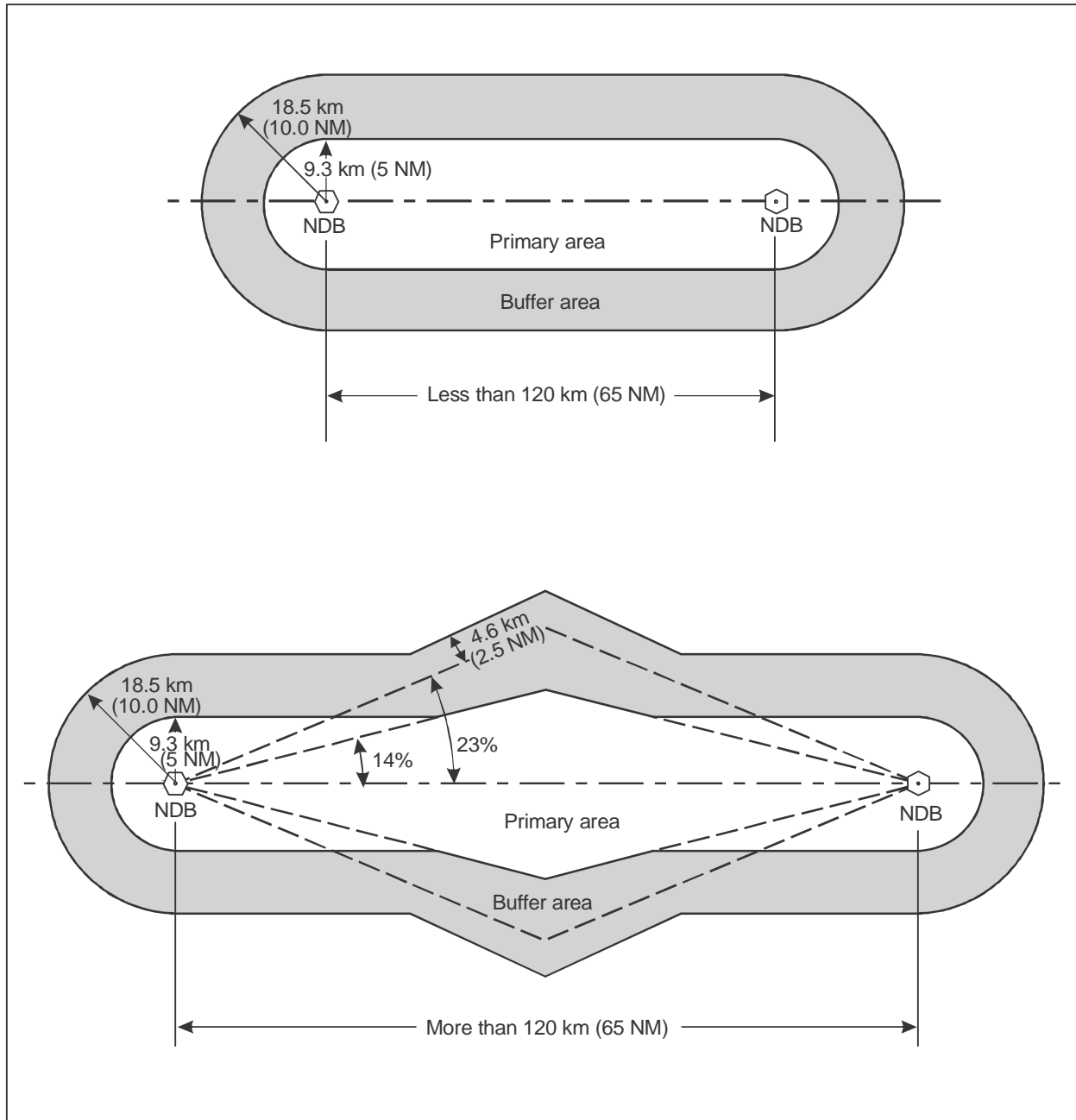

Figure II-3-1-3. Obstacle clearance areas for NDB en-route navigation. Straight segment

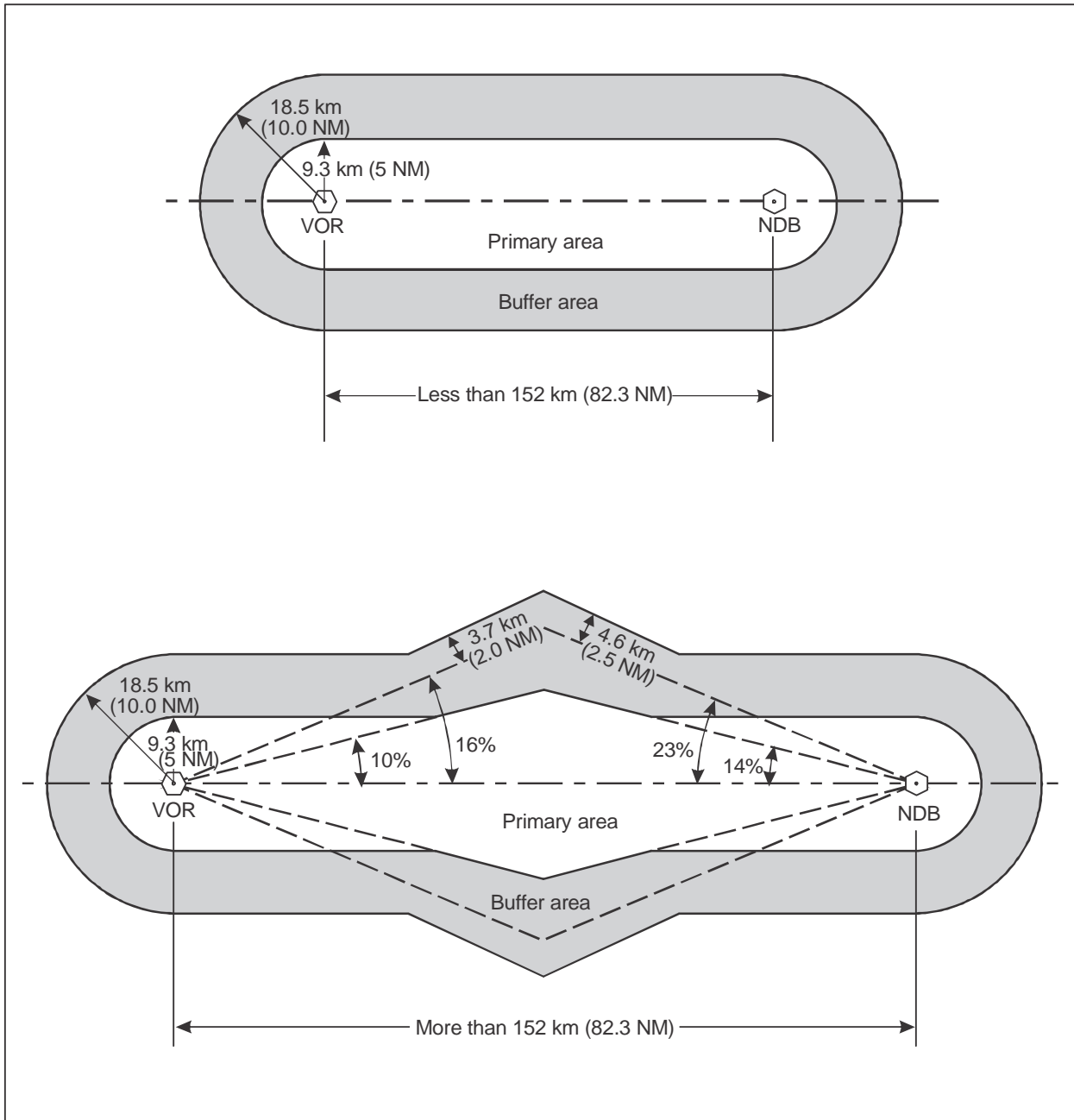

Figure II-3-1-4. Combination of VOR and NDB criteria

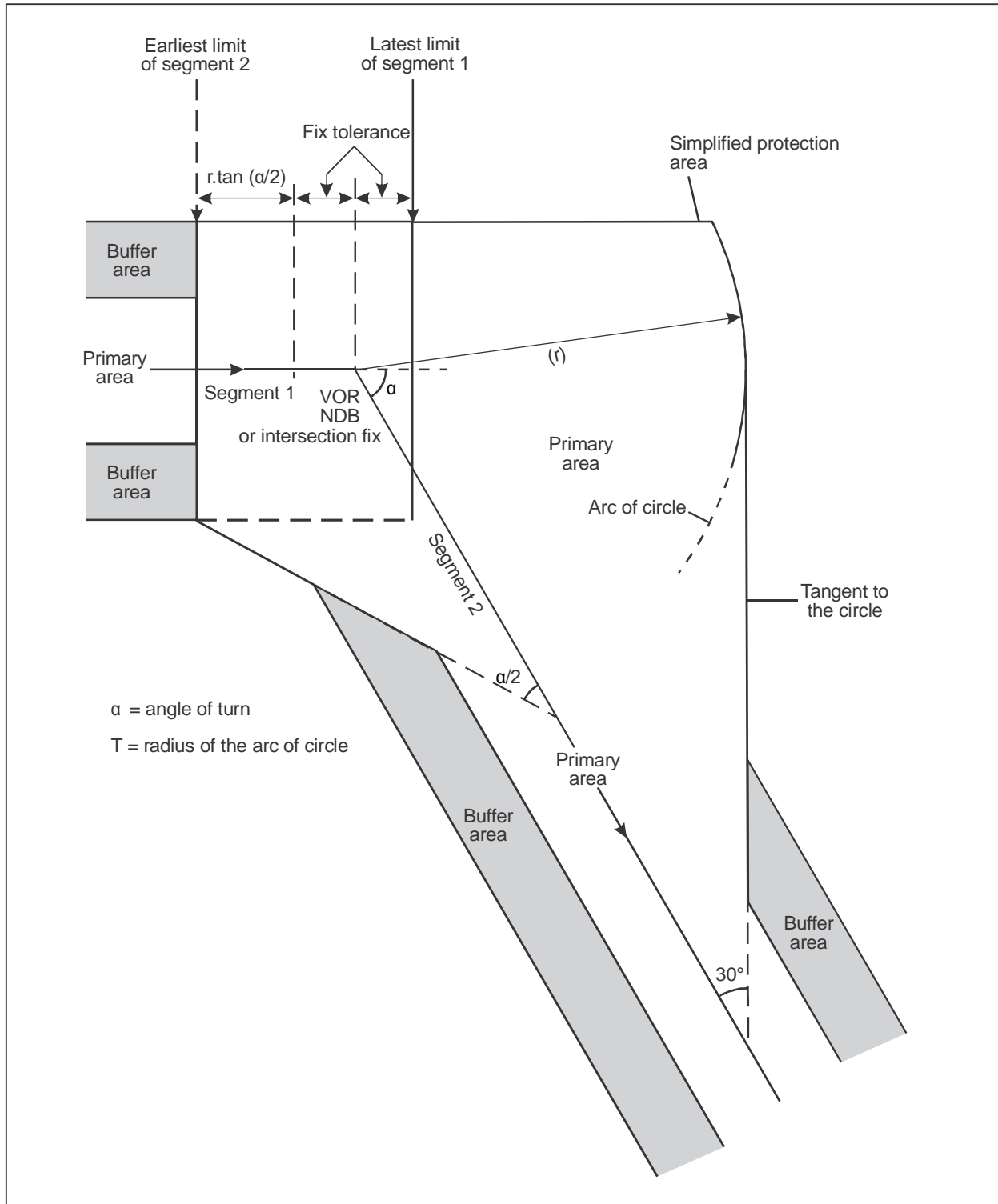

Figure II-3-1-5. Turn overhead a facility or at an intersection fix

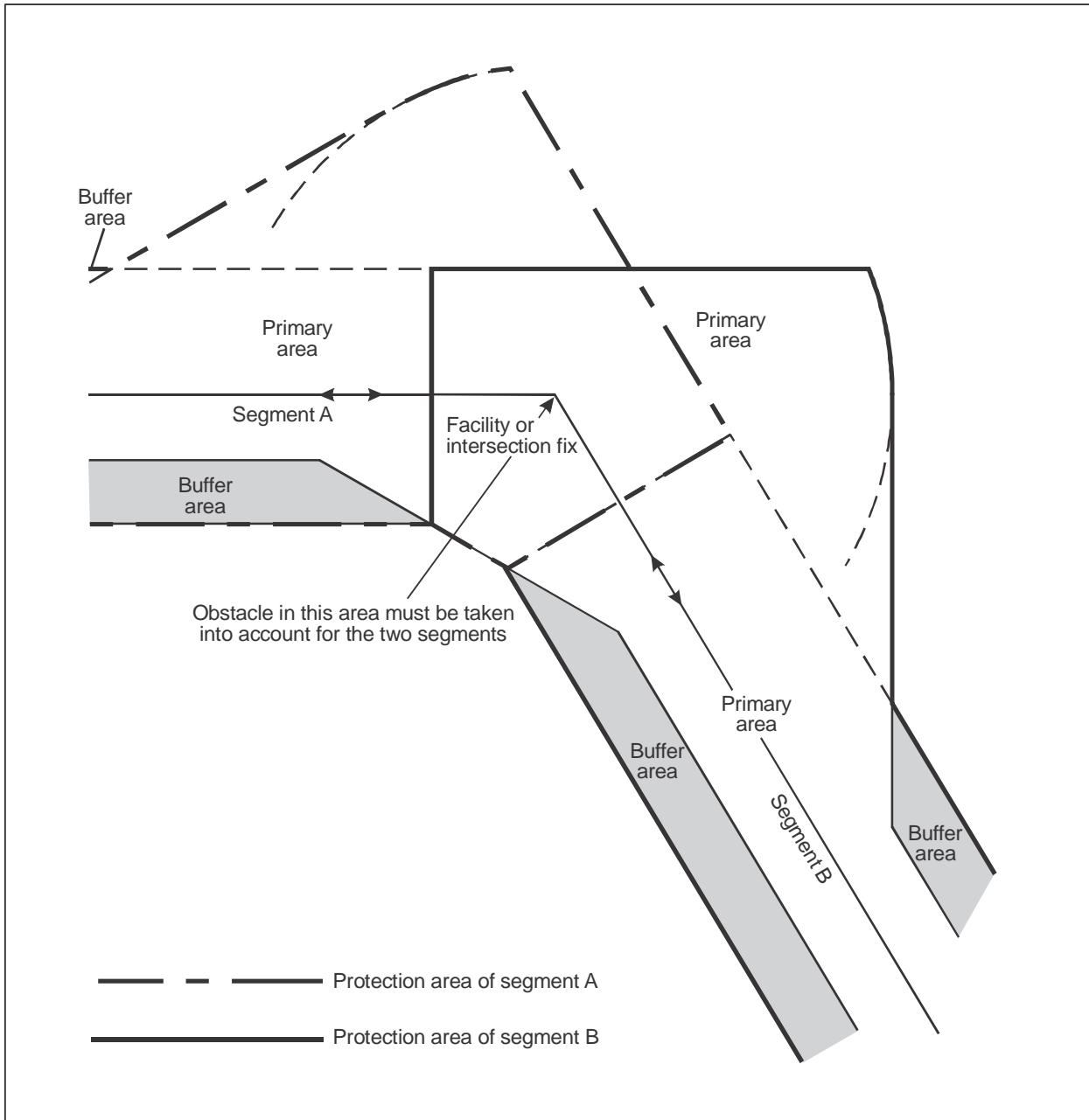
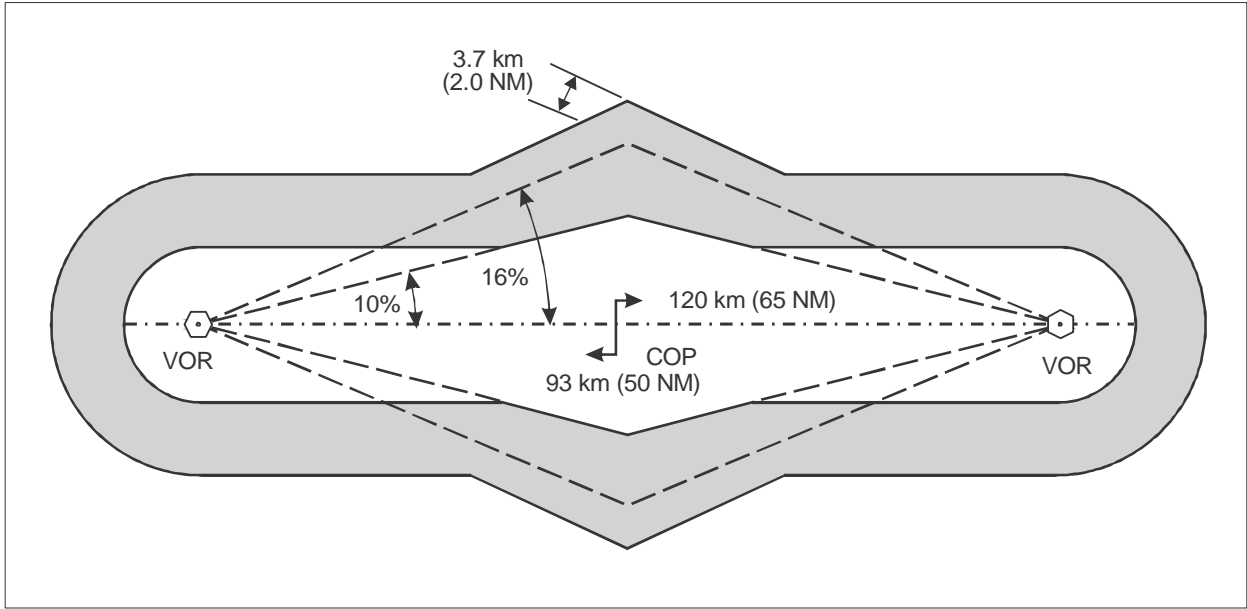

Figure II-3-1-6. Combination of turn areas for both directions of flight



**Figure II-3-1-7. Offset changeover point.
Example with two VORs**

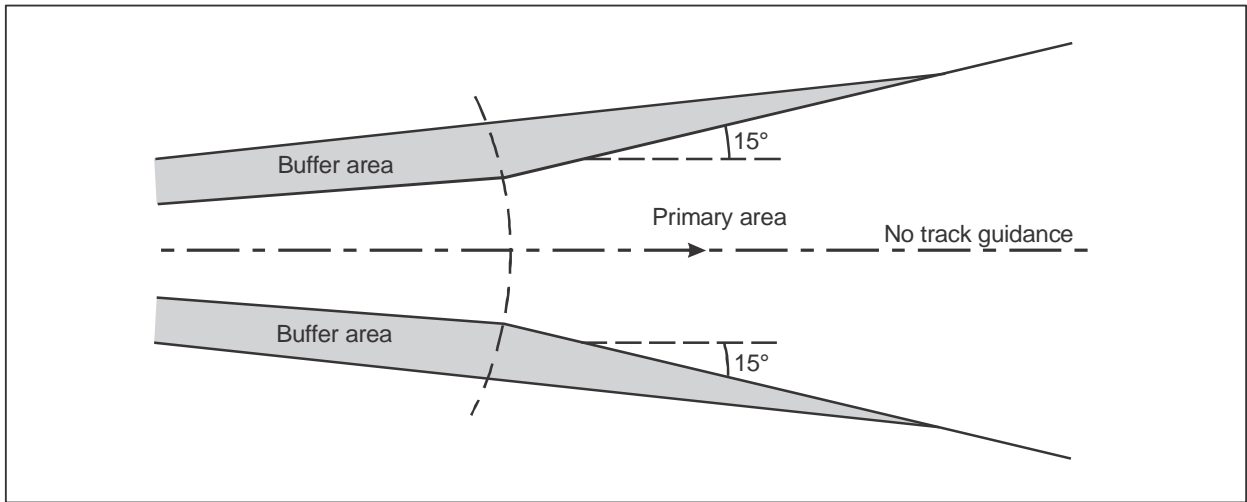

Figure II-3-1-8. Area without track guidance

Appendix A to Chapter 1

VOR AND NDB ROUTES — REFINED METHOD FOR THE CONSTRUCTION OF OBSTACLE CLEARANCE AREAS

1. GENERAL

1.1 Scope

The “refined method” presented in this appendix, related to obstacle clearance criteria for the en-route phase of an IFR flight, can be used when the criteria contained in Chapter 1 are not sufficient to address particular obstacle constraints. The criteria presented in this appendix amplify and/or modify the criteria as presented in Chapter 1.

2. OBSTACLE CLEARANCE AREAS

2.1 Primary and secondary areas

The obstacle clearance area is divided into a central primary area and two lateral secondary areas which replace the buffer areas in the standard method as described in Chapter 1.

2.2 Reductions to secondary area widths

Secondary areas for en-route operations may be reduced when justified by factors such as:

- a) when there is relevant information on flight operational experience;
- b) regular flight inspection of facilities to ensure better than standard signals; and/or
- c) radar surveillance.

3. OBSTACLE CLEARANCE

The criteria as contained in Chapter 1 apply. The MOC of the secondary area tapers from the full MOC of the primary area to zero at the outer edge.

4. CONSTRUCTION OF AREAS FOR VOR AND NDB ROUTES

4.1 VOR

4.1.1 *Constant width starting abeam the facility.* In Annex 11, Attachment A, values are indicated for the width of ATS routes navigated by VOR. Abeam the facility, values of ± 7.4 km (4 NM) and ± 11.1 km (6 NM) correspond respectively to 95 per cent and 99.7 per cent of probability of containment. The first value is specified for the limits of the primary area; the second value plus an additional value of 3.7 km (2.0 NM) is applied for the limits of the secondary area.

4.1.2 *Angular limits.* For distances greater than 70 km (38 NM) from the facility, the angular tolerances will cause the area width to increase. (See Figure II-3-1-App A-1.)

4.2 NDB

4.2.1 *Constant width starting abeam the facility.* To determine the width of the areas abeam the NDB, a factor of 1.25 is applied to the values specified in the VOR case, as in Part II, Section 2, Chapters 2 and 3. The resulting values are ± 9.3 km (5.0 NM) and ± 18.5 km (10.0 NM). (See Figure II-3-1-App A-2.)

4.2.2 *Angular limits.* For distances greater than 60 km (32 NM) from the facility, the angular tolerances will cause the area width to increase. (See Figure II-3-1-App A-2.)

4.3 Protection areas associated with turns

4.3.1 Turns can be executed overhead a facility or at a fix.

4.3.2 *Turn parameters.* The turn is constructed based on the parameters specified in Chapter 1, 1.4.3.3, “Turn parameters” and the following additional parameters:

- a) maximum pilot reaction time: 10 s; and
- b) bank establishment time: 5 s.

4.3.3 The turn area is constructed as follows (see Figures II-3-1-App A-3 and II-3-1-App A-4):

- a) on the outer edge of the turn, a wind spiral is constructed at the limit of the primary area and starting at a distance after the nominal turn point corresponding to the fix tolerance plus 15 seconds of flight at the nominal TAS plus a maximum tail wind. (See Part I, Section 2, Chapter 3 for the construction of the wind spiral); the convergence angle after the turn is 30° ; the secondary area width is constant throughout the turn; and
- b) on the inner edge of the turn, the primary area splays from a point located at a distance equal to $r \cdot \tan(\alpha/2)$ prior to the fix tolerance of the nominal turn point, at an angle of half the angle of turn. The secondary area width is constant during the turn.

If on one edge of the turn, the convergence angle cannot be used because the area of the segment being entered is already too wide, a splay angle of 15° is applied instead, measured from the nominal track of the segment being entered (see Figure II-3-1-App A-4).

5. PROMULGATION

5.1 *Minimum altitude.* The minimum obstacle clearance altitude (MOCA) and the minimum en-route altitude (MEA) are determined and published for each segment of the route.

5.2 Navigation system use accuracy

Smaller accuracy values may be used provided they are based on sufficient statistical data. Where different values are used they should be promulgated.

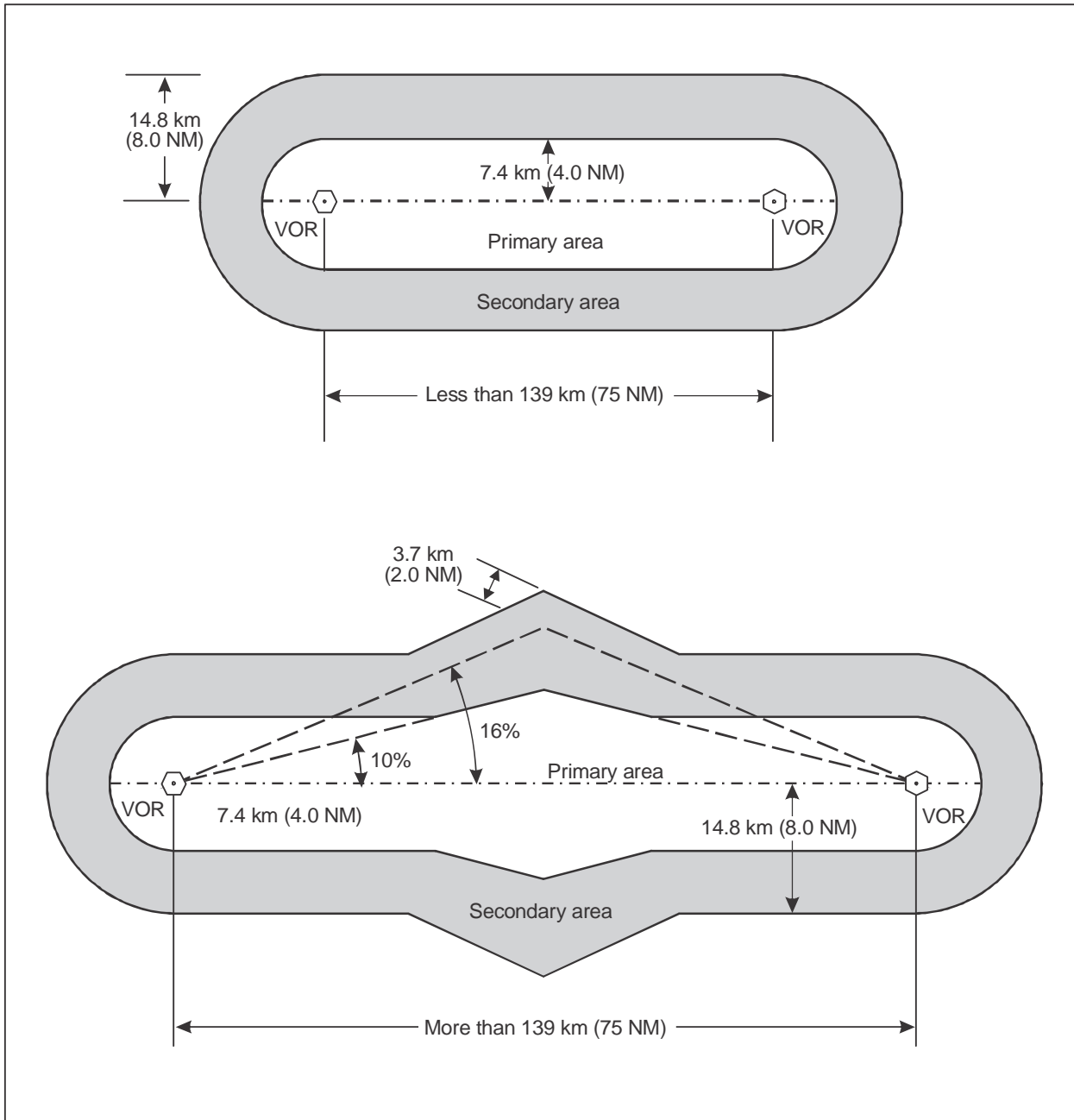

Figure II-3-1-App A-1. Obstacle clearance areas for VOR en-route navigation

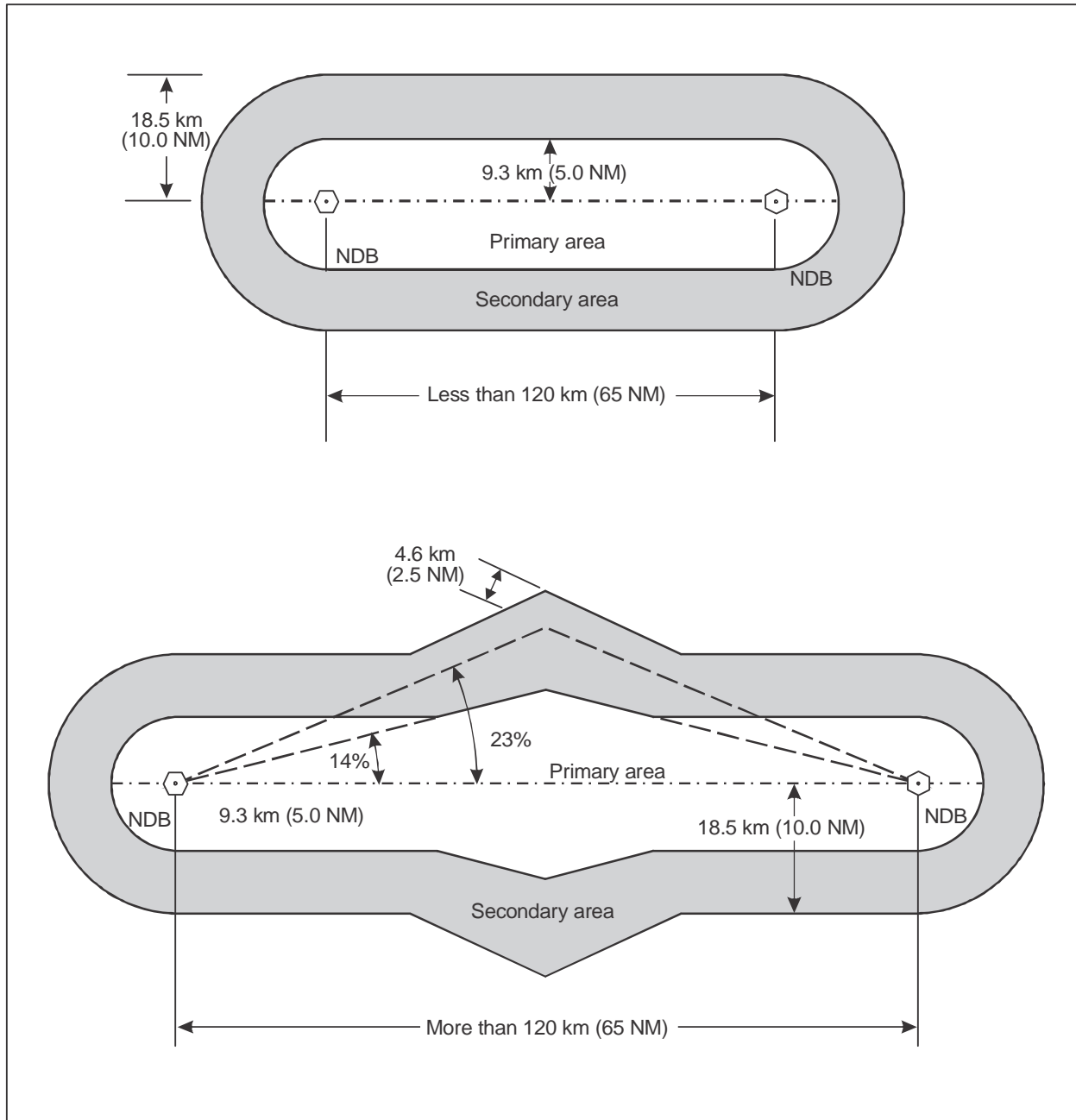

Figure II-3-1-App A-2. Obstacle clearance areas for NDB en-route navigation

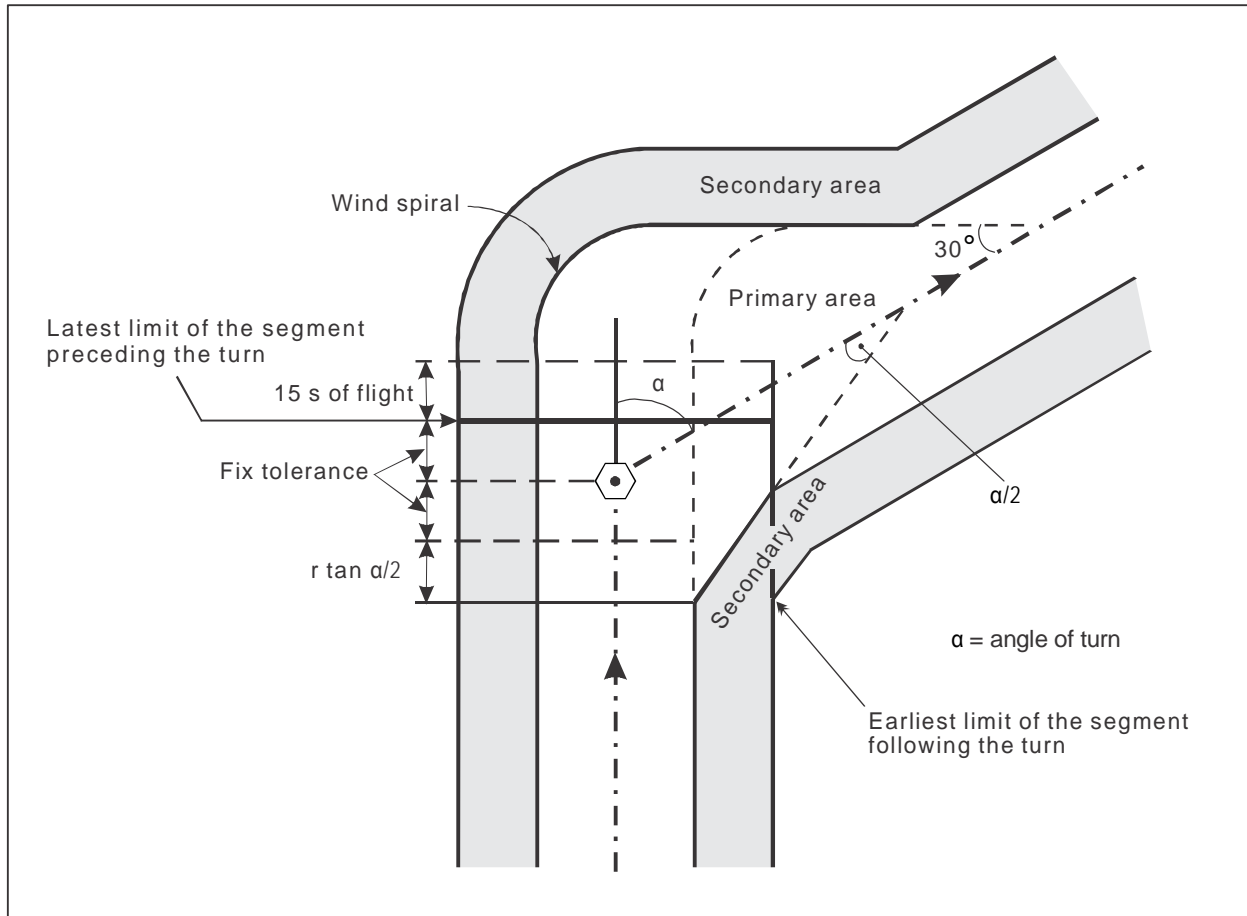

Figure II-3-1-App A-3. Turn overhead a facility

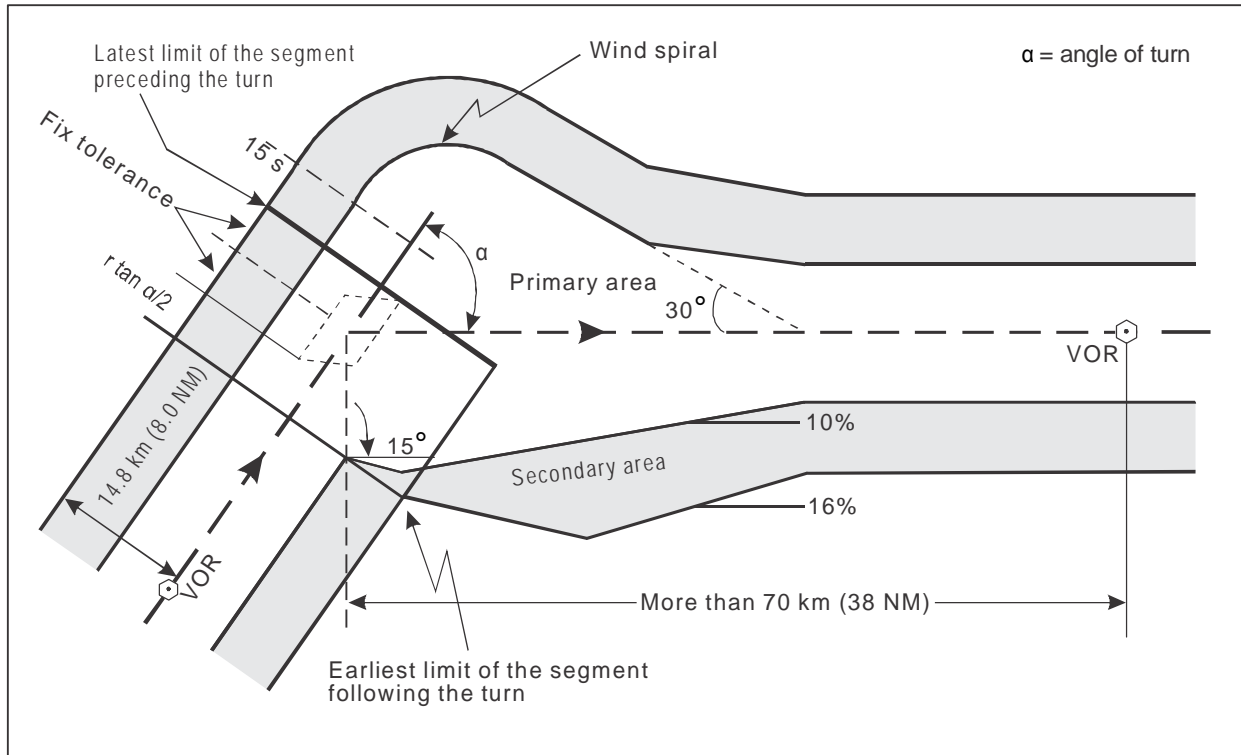

Figure II-3-1-App A-4. Turn at an intersection fix

Appendix B to Chapter 1

STATISTICAL CALCULATIONS FOR PRIMARY AND SECONDARY AREAS AND THEIR ANGLES OF SPLAY

1. GENERAL

The obstacle clearance area is divided into a central primary area and two buffer areas on either side. The primary area represents 95 per cent probability of containment (2 SD), as calculated on a root sum square basis from the system use accuracy. The buffer/secondary area represents 99.7 per cent probability of containment (3 SD), calculated in the same fashion.

2. NAVIGATION SYSTEM USE ACCURACY

2.1 The system accuracies used in the development of obstacle clearance criteria are based on minimum system performance factors. The various accuracy values, when considered as statistically independent, are combined on a root sum square (RSS) basis to produce limits corresponding to approximately 95 per cent probability of containment (2 SD) and limits corresponding to approximately 99.7 per cent probability of containment (3 SD).

2.2 The following system use accuracy values apply to VOR:

- a) $\pm 3.5^\circ$ ground system tolerance;
- b) $\pm 2.7^\circ$ receiver tolerance;
- c) $\pm 3.5^\circ$ flight technical tolerance; and
- d) $\pm 1.0^\circ$ monitoring tolerance.

2.3 The following system use accuracy values apply to NDB:

- a) $\pm 3^\circ$ ground equipment;
- b) $\pm 5.4^\circ$ airborne equipment; and
- c) $\pm 5^\circ$ flight technical tolerance.

2.4 *Fix or facility tolerances*

2.4.1 *VOR intersecting tolerance.* The VOR angular intersecting tolerance, calculated without the flight technical tolerance, results in 7.9 per cent (4.5°).

2.4.2 *NDB intersecting tolerance.* The NDB angular intersecting tolerance, calculated without the flight technical tolerance, results in 10.9 per cent (6.2°).

2.4.3 *Use of DME.* If available, DME can be used as a turning point fix. For DME accuracy values, see Part I, Section 2, Chapter 2, 2.4.4, “DME”.

2.4.4 *Facility tolerances – To be developed*

3. SPLAY

3.1 Primary area splay

3.1.1 The primary area splays at an angle of:

- a) 5.7° (10%) — VOR; and
- b) 7.95° (14%) — NDB.

3.1.2 *Primary area splay calculations.* These values are calculated as the root sum square of the system use accuracies values as given in 2.2 and 2.3. This gives a 95 per cent probability of containment (2 SD) of ± 9.87 per cent (5.64°) in the case of VOR, and ± 13.96 per cent (7.95°) in the case of NDB. The value of the primary area limit is rounded up to ± 10 per cent (5.7°) in the case of VOR. The value of the primary area limit is rounded up to ± 14 per cent (8.0°) in the case of NDB.

3.2 *Buffer area/secondary area splay.* The buffer area/secondary area splays at an angle of:

- a) 9.1° (15.86%) — VOR; and
- b) 13.0° (23%) — NDB.

3.3 *VOR buffer area/secondary area splay calculations.* In the calculation of the 99.7 per cent probability of containment (3 SD), the value of $\pm 1.0^\circ$ for the monitor tolerance is taken into account to replace $1.5 \times 3.5^\circ$ for the ground system tolerance by a maximum value of $3.5^\circ + 1.0^\circ = 4.5^\circ$. The combination on a root sum square basis gives a 3 SD limit of ± 14.08 per cent (8.01°). An additional value of $\pm 1.0^\circ$ is added, resulting in a total area limit of ± 15.86 per cent (9.01°). The splay of the total area is rounded up to ± 16 per cent (9.1°). (See Figure II-3-1-2 of Chapter 3.)

3.4 *NDB buffer area/secondary area splay calculations.* The calculation of the 99.7 per cent probability of containment (3 SD) and the addition of a $\pm 1.0^\circ$ buffer results in a total area limit of ± 22.94 per cent (12.92°). The splay of the total area is rounded up to ± 23 per cent (13.0°).

Section 4
HOLDING CRITERIA

Chapter 1

HOLDING CRITERIA

Note 1.— Guidance on parameters relating to holding areas for supersonic transport (SST) aircraft is contained in the “Statement of Operational Requirements” in ICAO Circular 126.

Note 2.— The criteria contained in this part are related to right turns holding patterns. If no operational considerations prevail, right turns holding patterns should be established. For left turns holding patterns, the corresponding entry and holding procedures are symmetrical with respect to the inbound holding track.

1.1 SHAPE AND TERMINOLOGY ASSOCIATED WITH HOLDING PATTERN

The shape and terminology associated with the holding pattern are given in Figure II-4-1-1.

1.2 ENTRY AND HOLDING PROCEDURES

The construction of a holding pattern shall be based on the following entry and holding procedures.

1.2.1 Entry procedures

Note.— Variations of the basic procedure to meet local conditions may be authorized by States after appropriate consultation with operators concerned.

1.2.1.1 Entry sectors

1.2.1.1.1 The entry into the holding pattern shall be according to heading, as it relates to the three entry sectors shown in Figure II-4-1-2. There is a zone of flexibility of 5° on either side of the sector boundaries.

1.2.1.1.2 In the case of holding on VOR intersections or VOR/DME fixes, entries will be limited to the radials. The criteria also provide for the protection of entries along DME arcs, but these should only be designed if there is a specific operational difficulty which makes the use of other entry procedures impossible.

1.2.1.2 Sector 1 procedure (parallel entry)

- a) Overhead the fix, the aircraft is turned onto an outbound heading (to a track parallel to the inbound track) for the appropriate period of time or distance; then
- b) turned left onto the holding side to intercept the inbound track or to return to the fix.

1.2.1.3 Sector 2 procedure (offset entry)

- a) Overhead the fix, the aircraft is turned onto a heading so that the track makes an angle of 30° from the reciprocal of the inbound track on the holding side; and
- b) flown outbound:
 - 1) for the appropriate period of time, where timing is specified; or
 - 2) until the appropriate DME distance is attained, where distance is specified; or
 - 3) where a limiting radial is also specified, either:
 - i) until the radial is encountered; or
 - ii) until the appropriate DME distance is reached, whichever occurs first; and then
- c) turned right to intercept the inbound track to the holding fix.

1.2.1.4 Sector 3 procedure (direct entry)

Overhead the fix, the aircraft is turned right and follows the holding pattern.

1.2.1.5 Special VOR/DME holding entry procedure

1.2.1.5.1 For entry into a VOR/DME holding pattern an entry radial to a secondary fix at the end of the outbound leg may be established (see Figure II-4-1-3 a) and b)). In this case Sector 1 and Sector 2 entries are not authorized.

1.2.1.5.2 The holding pattern will be entered directly along the entry radial or by the Sector 3 entry procedure. Having reached the secondary fix, the aircraft will turn right and follow the holding pattern. In this case the entry radial shall be published and clearly depicted.

1.2.2 Holding procedures

1.2.2.1 After completion of the sector entry, and overhead the fix for the second time (or on completion of a subsequent holding pattern) the aircraft is turned to fly an outbound track:

- a) for the appropriate period of time, if timing is specified; or
- b) until the appropriate DME distance is reached if distance is specified.

On completion of the outbound leg the aircraft will be positioned for the turn onto the inbound track, allowing for the effect of wind; and then turned to intercept the inbound track to the holding fix.

1.2.2.2 See 1.3.2, “Timing and distance” for the application of timing and distance limitations.

1.3 CONSTRUCTION OF HOLDING AREAS

1.3.1 Method of construction

1.3.1.1 Holding areas shall be constructed by a method which uses the input parameters and conditions specified in this part. One practical method is to construct a holding template that accommodates all the factors which may cause the aircraft to deviate from the nominal holding pattern. The limits of the holding area are then defined by applying this template to the boundaries of the fix tolerance area.

1.3.1.2 Details of the construction and application of this holding template method are described in Part I, Section 4, Chapter 3, Appendix C.

1.3.1.3 The calculations associated with the construction of basic holding areas and the respective omnidirectional entry areas require the use of the parameters given in 1.3.2 to 1.3.10.

1.3.1.4 *Aircraft holding at 520 km/h (280 kt)/0.8 Mach.* The possibility of aircraft having to hold at 520 km/h (280 kt)/0.8 Mach indicated airspeed in conditions of turbulence shall be taken into account. Whenever the holding area cannot accommodate aircraft required to hold at 520 km/h (280 kt)/0.8 Mach, suitable air traffic control (ATC) procedures should be established to handle aircraft requesting this speed.

Note.— Such ATC procedures might take the form of action to protect additional airspace or issue an alternative clearance, including holding outside the normal holding areas, or diversion.

1.3.2 Timing and distance

1.3.2.1 Start of timing

Outbound timing starts abeam the fix or on attaining the outbound heading, whichever comes later.

1.3.2.2 Outbound timing

1.3.2.2.1 *Aeroplane timing.* In constructing the outbound leg length based on time flown, the outbound timing should be:

- a) one minute up to and including 4 250 m (14 000 ft); and
- b) one and one-half minutes above 4 250 m (14 000 ft);

however, it may be increased provided the protected airspace is adjusted in accordance with the principles contained in this chapter.

1.3.2.2.2 *Helicopter timing.* The outbound timing should be:

- a) one minute up to and including 1 830 m (6 000 ft); and
- b) Category A fixed-wing aeroplane criteria above 1 830 m (6 000 ft).

1.3.2.3 *Outbound distance*

The specified DME outbound distance should be expressed in terms of distance equivalent to at least one minute of flight time at the selected true air speed (TAS). When this is done, make certain that:

- a) at least 30 seconds will be available on the inbound track after completion of the inbound turn; and that
- b) slant range is taken into account.

1.3.2.4 *Limiting radial*

In the case of holding away from the station, if the distance from the holding fix to the VOR/DME station is so short that there is no chance of even the most adverse outbound track or Sector 2 entry track intersecting the limiting DME distance, a limiting radial shall be specified. A limiting radial may also be specified where airspace conservation is essential.

Note.— The limiting radial shall be a radial from the VOR/DME on which the holding is based. (See 4.4.)

1.3.3 **Indicated airspeed**

1.3.3.1 *General*

1.3.3.1.1 Areas should be calculated and drawn to accommodate the fastest aircraft category. The indicated airspeeds shown in Table II-4-1-2 should be used in calculating holding areas.

1.3.3.1.2 Although the area based on the slow speed (i.e. 165 km/h (90 kt)) aircraft in strong winds may in some places be larger than the area constructed in this manner, the normal operational adjustments made by the pilots of such aircraft should keep the aircraft within the area.

1.3.3.1.3 For conversion from indicated airspeeds to true airspeeds, see temperature considerations in 1.3.7, “Temperature” and Appendix A to this chapter.

Note.— The speeds given in Table II-4-1-2 are converted and rounded to the nearest multiple of five for operational reasons and from the standpoint of operational safety are considered to be equivalent.

1.3.3.2 *Airspeeds*

The speeds upon which the holding area is based should be published.

1.3.3.3 *Entry speeds under limited position fixing capabilities*

Where position fixing capabilities preceding the holding fix are limited, the competent authority should consider planning holding areas to accommodate initial entry speeds greater than prescribed.

1.3.4 Angle of bank or rate of turn

The angle of bank to be taken into consideration should be 25°. The formula for deriving rate of turn from angle of bank is contained in Appendix A to this chapter. Graphs for deriving rate of turn from angle of bank appear at Appendix A to this chapter, Figures II-4-1-App A-1 and II-4-1-App A-2.

1.3.5 Navigation accuracy

Accuracy values for constructing holding areas are given in Part I, Section 2, Chapter 2, 2.3.3, “System use accuracy”.

1.3.6 Wind velocity

1.3.6.1 Where statistical wind data are available, the maximum wind speed within 95 per cent probability should be used on an omnidirectional basis for calculations. However, component wind velocities derived from the 95 per cent statistical data may be used instead of omnidirectional winds.

1.3.6.2 Where statistical wind data are not available, omnidirectional winds calculated from either of the formulae contained in Appendix A to this chapter, 6.6, or read from the graph at Appendix A to this chapter (Figure II-4-1-App A-4) should be used.

Note.— Where two adjacent holding pattern areas overlap, it may be possible to designate these patterns as laterally separated. In such cases the State concerned establishes that winds from different directions would be required in order for conflict to occur. The basic holding area plus the entry area should be applied in determining lateral separation between each pattern and other adjacent areas of probability, e.g. air routes.

1.3.7 Temperature

Where climatological data are available the maximum temperature within the 95 per cent probability should be used for calculations. Where adequate climatological data are not available, the international standard atmosphere (ISA) plus 15° Celsius temperature gradient should be used. ISA + 15°C graph is in Appendix A to this chapter (Figure II-4-1-App A-5). Tables of conversion from indicated airspeeds to true airspeeds at ISA + 15°C are contained at Appendix A to this chapter (Tables II-4-1-App A-1 and II-4-1-App A-2).

1.3.8 Flight levels

Where a holding area is to be applied to a block of flight levels it should be applied *only* to the level for which plotted or *below*.

1.3.9 Flight technical tolerance

The tolerances in this section are applied as shown in Part I, Section 4, Chapter 3, Figure I-4-3-8.

1.3.9.1 *Fix tolerance.* On passage over the fix, an overall tolerance of 11 seconds shall be applied to the fix position tolerance area. This is comprised of:

- a) 6 seconds tolerance for pilot reaction; and
- b) 5 seconds for establishment of bank.

1.3.9.2 *Outbound leg tolerance.* On the outbound leg, an overall tolerance of + 15 seconds to – 5 seconds shall be applied. This is comprised of:

- a) ± 10 seconds tolerance for timing; and
- b) 5 seconds for establishment of bank.

1.3.9.3 *DME distance tolerance.* In cases where DME is utilized a tolerance of 11 seconds should be applied to the DME distance tolerance.

1.3.10 Heading tolerance

A tolerance of ± 5° in heading should be allowed for on the outbound leg of the pattern.

1.3.11 Effect of entry track on the dimension of the basic holding area

The area of holding patterns shall be adjusted for the various types of entries by applying the parameters in 3.2 through 3.10 to the entry procedures. This generally requires additional airspace to the basic area (see 1.3.12, “Obstacle clearance”).

1.3.12 Obstacle clearance

1.3.12.1 *Holding area components.* The holding area includes the basic holding area, the entry area, and the buffer area.

- a) The basic holding area at any particular level is the airspace required at that level for a standard holding pattern based on the allowances for aircraft speed, wind effect, timing errors, holding fix characteristics, etc.
- b) The entry area includes the airspace required to accommodate the specified entry procedures.
- c) The buffer area extends 9.3 km (5.0 NM) (Cat H, 3.7 km (2.0 NM) at or below 1 830 m (6 000 ft)) beyond the boundary of the holding area. In this buffer area the height and nature of obstacles shall be taken into consideration when determining the minimum usable holding level in the holding pattern.

1.3.12.2 MOC

1.3.12.2.1 The minimum permissible holding level shall provide a clearance of at least:

- a) 300 m (984 ft) above obstacles in the holding area; and
- b) the appropriate value from Table II-4-1-1 above obstacles in the buffer area. This value decreases stepwise outward.

1.3.12.2.2 *Obstacle clearance over high terrain.* Over high terrain or in mountainous areas, obstacle clearance up to a total of 600 m (1 969 ft) shall be provided to accommodate the possible effects of turbulence, down draughts and other meteorological phenomena on the performance of altimeters, as indicated in the guidance material in Part II, Section 4, Chapter 1, Appendix B. (See also Figure II-4-1-4. For Cat H, see Figure II-4-1-5.)

1.4 SPECIAL CONDITIONS FOR PLANNING VOR/DME HOLDING PROCEDURES AND CONSTRUCTION OF ASSOCIATED AREAS

1.4.1 General

The general provisions of sections 1.1, 1.2 and 1.3 of this chapter apply. Information contained in Part I, Section 4, Chapter 3, Appendix A should be used for calculating and constructing the holding area.

1.4.2 VOR/DME system requirements

The use of the VOR/DME system is limited by the following requirements:

- a) the holding area must lie within the designated operational coverage of the VOR and DME;
- b) the cone of ambiguity of the VOR:
 - 1) must not overlap the holding area for holding away from the station; and
 - 2) must not overlap the holding fix in the case of holding towards the station;
- c) the minimum usable DME ground distance must overlap neither the holding fix nor the limiting distance of the outbound leg; and
- d) the VOR and DME facilities must be collocated and the inbound track aligned on the specified VOR radial.

The minimum usable ground distance to a VOR/DME fix for holding is subject to the limitations given in Part I, Section 2, Chapter 2, 2.6.1, “Minimum usable ground distance to a VOR/DME fix”.

1.4.3 DME arc radius

1.4.3.1 If DME arc is used to provide track guidance for entry to the holding pattern, the arc radius shall not be less than 13 km (7 NM).

1.4.3.2 Variations, to meet local conditions, may be authorized after appropriate consultation with the operator concerned.

1.4.4 Operationally-preferred procedures

The following procedures should be used, if possible:

- a) the inbound track should be towards the facility. However, if it is necessary to hold away from the station, the holding distance should be chosen so as to avoid the necessity for a limiting radial; and
- b) the entry to the pattern should be along the inbound track to the holding fix.

Note 1.— The entry may be assisted by radar, by establishment of a navigation fix beyond the holding pattern on the extended inbound track, etc.

Note 2.— Entries on DME arcs should only be designed if there is a specific operational difficulty which makes the use of other entry procedures impossible.

Note 3.— Entry procedures from other navigation facilities may require additional protected airspace.

1.4.5 VOR cone effect

In calculations of the VOR cone effect area and DME slant range conversions, the height above the facility (hl) is to be used (see Appendix A to this Chapter, 6.4 and 6.5).

1.5 PROMULGATION

1.5.1 Special VOR/DME holding entry procedure

1.5.1.1 For entry into a VOR/DME holding pattern an entry radial to a secondary fix at the end of the outbound leg may be established (see Figure II-4-1-3 a) and b)). In this case Sector 1 and Sector 2 entries are not authorized.

1.5.1.2 The holding pattern will be entered directly along the entry radial or by the Sector 3 entry procedure. Having reached the secondary fix, the aircraft will turn right and follow the holding pattern. In this case the entry radial shall be published and clearly depicted.

1.5.2 Airspeeds

1.5.2.1 The speeds upon which the holding area is based should be published.

1.5.2.2 Slant range distances for VOR/DME holding

1.5.2.2.1 The distance of holding fix and the limiting outbound distance shall be expressed in whole kilometres (nautical miles) as the slant-range from the DME station.

1.5.2.2.2 Slant-range distances together with the limiting radial (where specified), shall be published on the appropriate aeronautical chart to be used by the pilot.

Table II-4-1-1. Minimum obstacle clearance in the buffer area over low flat terrain

<i>Distance beyond the boundary of the holding area</i>		<i>Minimum obstacle clearance over low flat terrain</i>	
<i>Kilometres</i>	<i>Nautical miles</i>	<i>Metres</i>	<i>Feet</i>
0 to 1.9	0 to 1.0	300	984
1.9 to 3.7	1.0 to 2.0	150	492
3.7 to 5.6	2.0 to 3.0	120	394
5.6 to 7.4	3.0 to 4.0	90	294
7.4 to 9.3	4.0 to 5.0	60	197
Category H			
0. to 3.7	0 to 2.0	linear	linear
		300 to 0	984 to 0

Table II-4-1-2. Airspeeds for holding area construction

<i>Levels¹</i>	<i>Normal conditions</i>	<i>Turbulence conditions</i>
Helicopters up to 1 830 m (6 000 ft) inclusive	185 km/h (100 kt)	
up to 4 250 m (14 000 ft) inclusive	425 km/h (230 kt) ² 315 km/h (170 kt) ⁴	520 km/h (280 kt) ³ 315 km/h (170 kt) ⁴
above 4 250 m (14 000 ft) to 6 100 m (20 000 ft) inclusive above 6 100 m (20 000 ft) to 10 350 m (34 000 ft) inclusive	445 km/h (240 kt) ⁵ 490 km/h (265 kt) ⁵	520 km/h (280 kt) or 0.8 Mach, whichever is less ³
above 10 350 m (34 000 ft)	0.83 Mach	0.83 Mach
<ol style="list-style-type: none"> 1. The levels tabulated represent <i>altitudes</i> or corresponding <i>flight levels</i> depending upon the altimeter setting in use. 2. When the holding procedure is followed by the initial segment of an instrument approach procedure promulgated at a speed higher than 425 km/h (230 kt), the holding should also be promulgated at this higher speed wherever possible. 3. See 1.3.1.4, “Aircraft holding at 520 km/h (280 kt)/0.8 Mach”. 4. For holdings limited to Cat A and B aircraft only and Cat H above 1 830 m (6 000 ft). 5. Wherever possible, 520 km/h (280 kt) should be used for holding procedures associated with airway route structures. 		

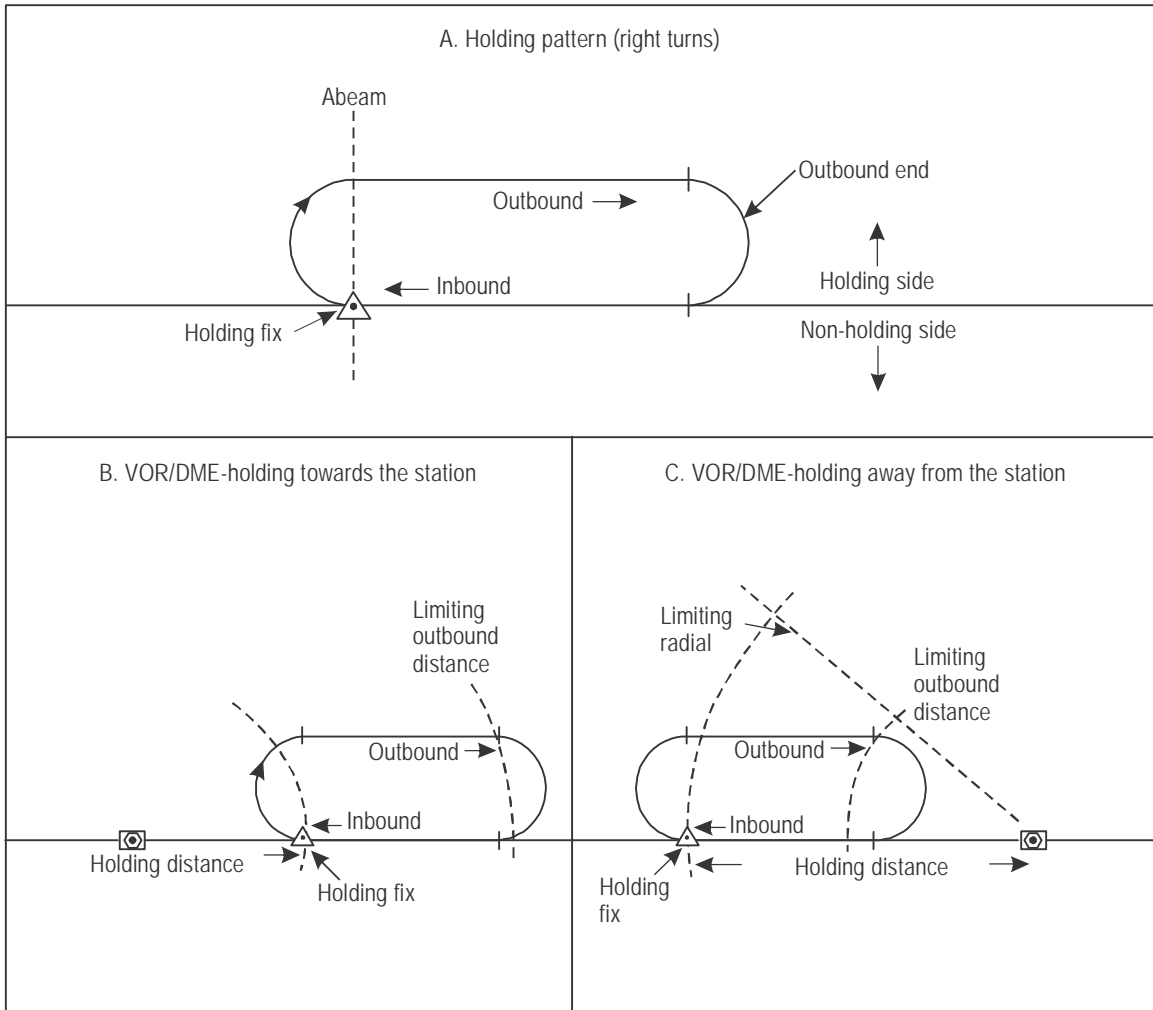

Figure II-4-1-1. Shape and terminology associated with right turns holding pattern

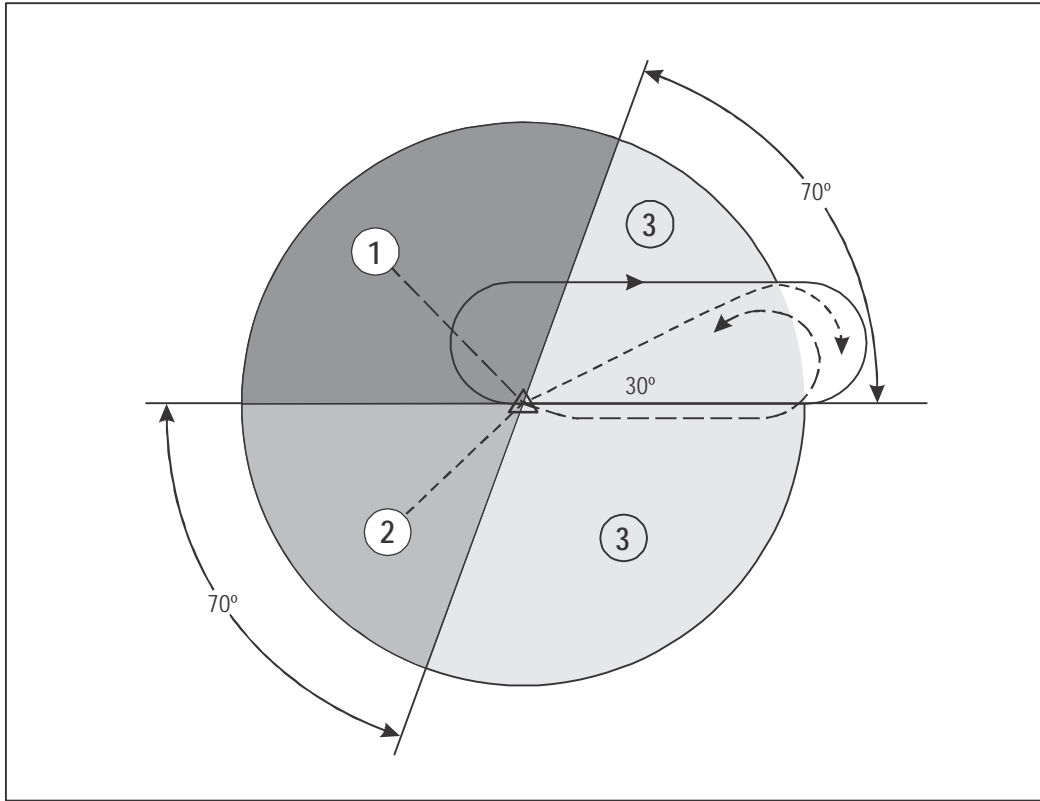

Figure II-4-1-2. Entry sectors

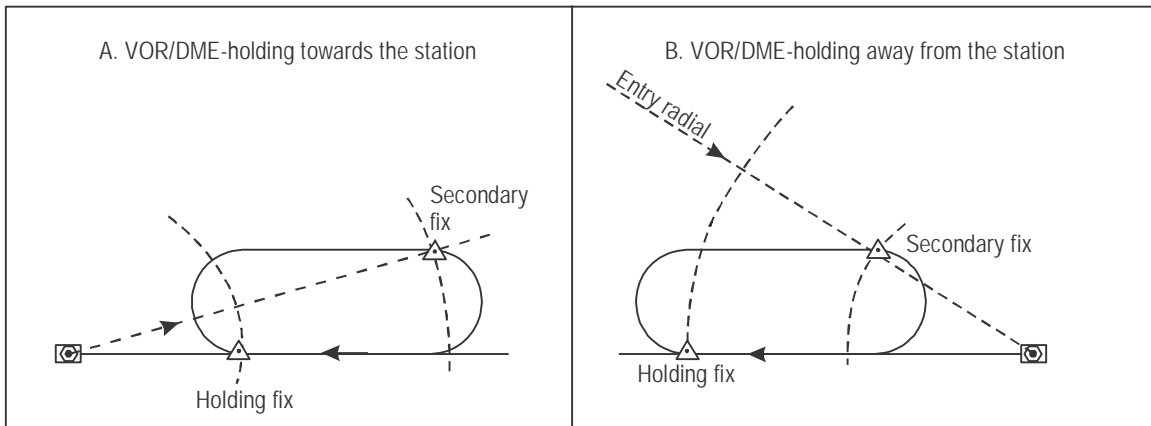

Figure II-4-1-3. Entry to a VOR/DME fix on the outbound leg

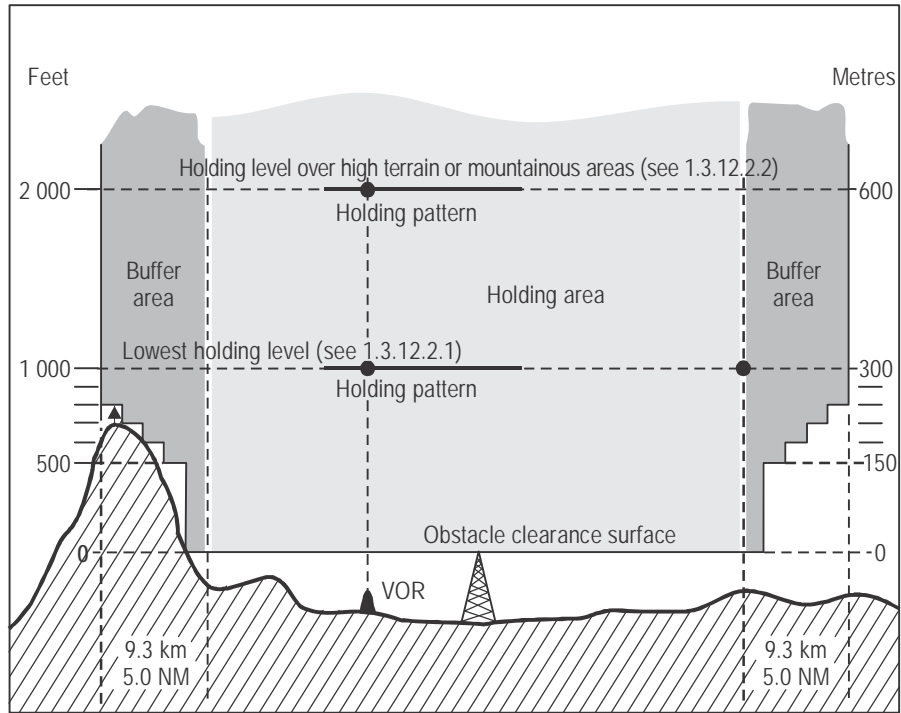

Figure II-4-1-4. Minimum holding level as determined by the obstacle clearance surface related to the holding area and the buffer area

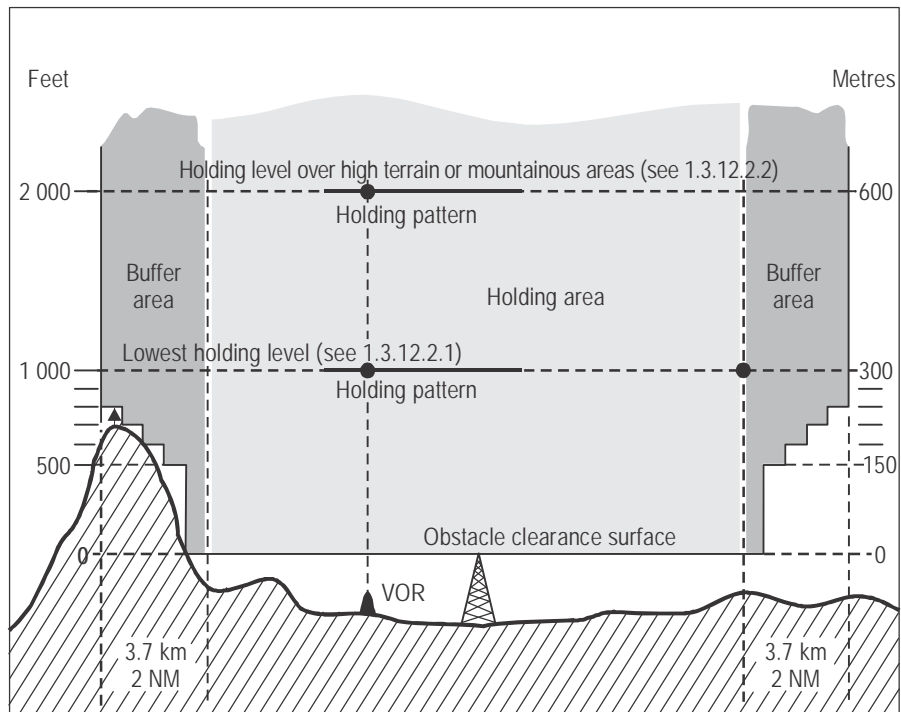

Figure II-4-1-5. Holding area up to 1 830 m (6 000 ft) for helicopters

Appendix A to Chapter 1

PARAMETERS FOR HOLDING AREA CONSTRUCTION

The material in this attachment provides general information on some of the parameters used for holding area construction. Parameters for which information is provided are as follows:

1. Turn parameters
2. Accountable wind vs. altitude
3. Temperature vs. altitude
4. DME slant range vs. ground distance
5. True airspeed (TAS) vs. indicated airspeed (IAS) and altitude
6. Formulae for basic holding area parameter calculations.

1. TURN PARAMETERS

(See also Part I, Section 2, Chapter 3)

Applicable turn parameters are given in Figures II-4-1-App A-1, II-4-1-App A-2 and II-4-1-App A-3.

2. ACCOUNTABLE WIND VS. ALTITUDE

The accountable omnidirectional wind speed given in Figure II-4-1-App A-4 for specified altitude is calculated according to the following formula:

$w = (12 h + 87) \text{ km/h}$, where h is in thousands of metres,

or

$w = (2 h + 47) \text{ kt}$, where h is in thousands of feet.

3. TEMPERATURE VS. ALTITUDE

See Figure II-4-1-App A-5.

4. DME SLANT RANGE VS. GROUND DISTANCE

See Figures II-4-1-App A-6 and II-4-1-App A-7.

5. TRUE AIRSPEED (TAS) VS. INDICATED AIRSPEED (IAS) AND ALTITUDE

Table II-4-1-App A-1 gives the true airspeed in km/h and Table II-4-1-App A-2 gives the true airspeed in kt at temperature ISA + 15°C including correction for the compressibility effect. For calculation formula, see 6.1 of this attachment.

Note.— These tables are only to be used in the construction of holding areas.

6. FORMULAE FOR BASIC HOLDING AREA PARAMETER CALCULATIONS

6.1 True airspeed calculation formula (*including compressibility effect*)

$$V = 102.06\sqrt{T} \sqrt{\sqrt{1 + 0.00067515 \frac{IAS^2}{P} \left(1 + \frac{IAS^2}{6003025}\right)} - 1}$$

where: T = temperature in K at ISA + 15;

P = pressure in hPa;

IAS = indicated airspeed in km/h; and

V = true airspeed in km/h

or

$$V = 55.1088\sqrt{T} \sqrt{\sqrt{1 + 0.0023157 \frac{IAS^2}{P} \left(1 + \frac{IAS^2}{1750200}\right)} - 1}$$

where: T = temperature in K at ISA + 15;

P = pressure in hPa;

IAS = indicated airspeed in kt; and

V = true airspeed in kt.

For values of P and T, see the *Manual of ICAO Standard Atmosphere* (Doc 7488).

6.2 Rate of turn calculation formula

$$R = \frac{6355 \tan \alpha}{\pi V}$$

where: α = angle of bank in degrees;
 V = true airspeed in kilometres per hour; and
 R = rate of turn in degrees per second.

or

$$R = \frac{3431 \tan \alpha}{\pi V}$$

where: α = angle of bank in degrees;
 V = true airspeed in knots; and
 R = rate of turn in degrees per second.

6.3 Radius of turn (r)

$$r = \frac{0.18V}{\pi R}$$

where: V = true airspeed in metres per second;
 R = rate of turn; and
 r = radius of turn in kilometres

or

$$r = \frac{3V}{\pi R}$$

where: V = true airspeed in nautical miles per minute;
 R = rate of turn; and
 r = radius of turn in nautical miles.

6.4 Cone effect area radius calculation formula

$$z = hl \tan \gamma l$$

where: hl = height above the facility in thousands of metres;
 γl = 1/2 cone angle in degrees; and
 z = radius of the cone effect area in kilometres

or

$$z = 0.164 h_1 \tan \gamma_1$$

where: h_1 = height above facility in thousands of feet;
 γ_1 = 1/2 cone angle in degrees; and
 z = radius of the cone effect area in nautical miles.

6.5 Minimum usable DME ground distance calculation formula

$$dm = h_l \tan 55^\circ$$

where: h_l = height above the facility in thousands of metres; and
 dm = minimum usable DME ground distance in kilometres

or

$$dm = 0.164 h_l \tan 55^\circ$$

where: h_l = height above the facility in thousands of feet; and
 dm = minimum usable DME ground distance in nautical miles.

6.6 Wind velocity calculation formula

$$w = 12 h + 87$$

where: h = altitude in thousands of metres;
 w = wind speed in kilometres per hour (up to 220)

or

$$w = 2 h + 47$$

where: w = wind speed in knots (up to 120); and
 h = altitude in thousands of feet.

Table II-4-1-App A-1. True airspeed (TAS) vs. indicated airspeed (IAS) and altitude (SI units)

<i>Altitude (metres)</i>	<i>315 km/h</i>	<i>425 km/h</i>	<i>445 km/h</i>	<i>490 km/h</i>	<i>520 km/h</i>	<i>0.8 M</i>	<i>0.83 M</i>
300	327.6	442.10			540.72		
600	332.28	448.42			548.28		
900	337.32	454.86			556.2		
1 200	342.0	461.43			564.12		
1 500	347.4	468.13			571.68		
1 800	352.8	474.97			580.32		
2 100	357.48	481.95			588.6		
2 400	362.88	489.04			596.88		
2 700	369.0	496.33			605.88		
3 000	374.4	503.75			614.52		
3 300	380.52	511.31			623.52		
3 600	385.92	519.04	568.08		632.88		
3 900	391.68	526.92			641.88		
4 200	398.52	534.97			651.6		
4 500					661.68		
4 800			577.08		671.4		
5 100			585.72		681.48		
5 400			595.08		691.92		
5 700			604.08		702.72		
6 000			613.8		713.52		
6 300				684.15	724.32		
6 600				694.83	735.48		
6 900				705.74	747.0		
7 200				716.86	758.5		
7 500				728.21	770.4		
7 800				739.80	782.28		
8 100				751.62	794.8		
8 400				763.68	807.48		
8 700				775.99	820.08		
9 000				788.55	833.4		
9 300				801.37	846.2	863.90	888.48
9 600				814.45	860.4	860.14	
9 900				827.79			
10 200				841.41			
10 500							
10 800							884.55
11 100							881.67
and above							

Table II-4-1-App A-2. True airspeed (TAS) vs. indicated airspeed (IAS) and altitude (non-SI units)

<i>Altitude (feet)</i>	<i>170 kt</i>	<i>230 kt</i>	<i>240 kt</i>	<i>265 kt</i>	<i>280 kt</i>	<i>0.8 M</i>	<i>0.83 M</i>
1 000	177.0	239.26			291.0		
2 000	179.4	242.68			295.2		
3 000	182.4	246.16			299.4		
4 000	184.8	249.72			304.2		
5 000	187.8	253.34			308.4		
6 000	190.8	257.04			312.6		
7 000	193.2	260.82			317.4		
8 000	196.2	264.67			322.2		
9 000	199.2	268.60			327.0		
10 000	202.8	272.61			331.8		
11 000	205.8	276.71			336.6		
12 000	208.8	280.88	307.8		342.0		
13 000	212.4	285.15			346.8		
14 000	215.4	289.50			352.2		
15 000					357.6		
16 000			312.6		363.0		
17 000			317.4		368.4		
18 000			322.2		374.4		
19 000			327.6		380.4		
20 000			333.0		386.4		
21 000				369.98	392.4		
22 000				375.76	398.4		
23 000				381.65	405.0		
24 000				387.67	411.0		
25 000				393.81	417.6		
26 000				400.07	424.2		
27 000				406.46	431.4		
28 000				412.98	438.0		
29 000				419.63	445.2		
30 000				426.42	452.4		
31 000				433.35	460.2	466.47	479.74
32 000				440.42	467.4	464.44	
33 000				447.64			
34 000				455.00			
35 000							
36 000							477.62
37 000 and above							476.06

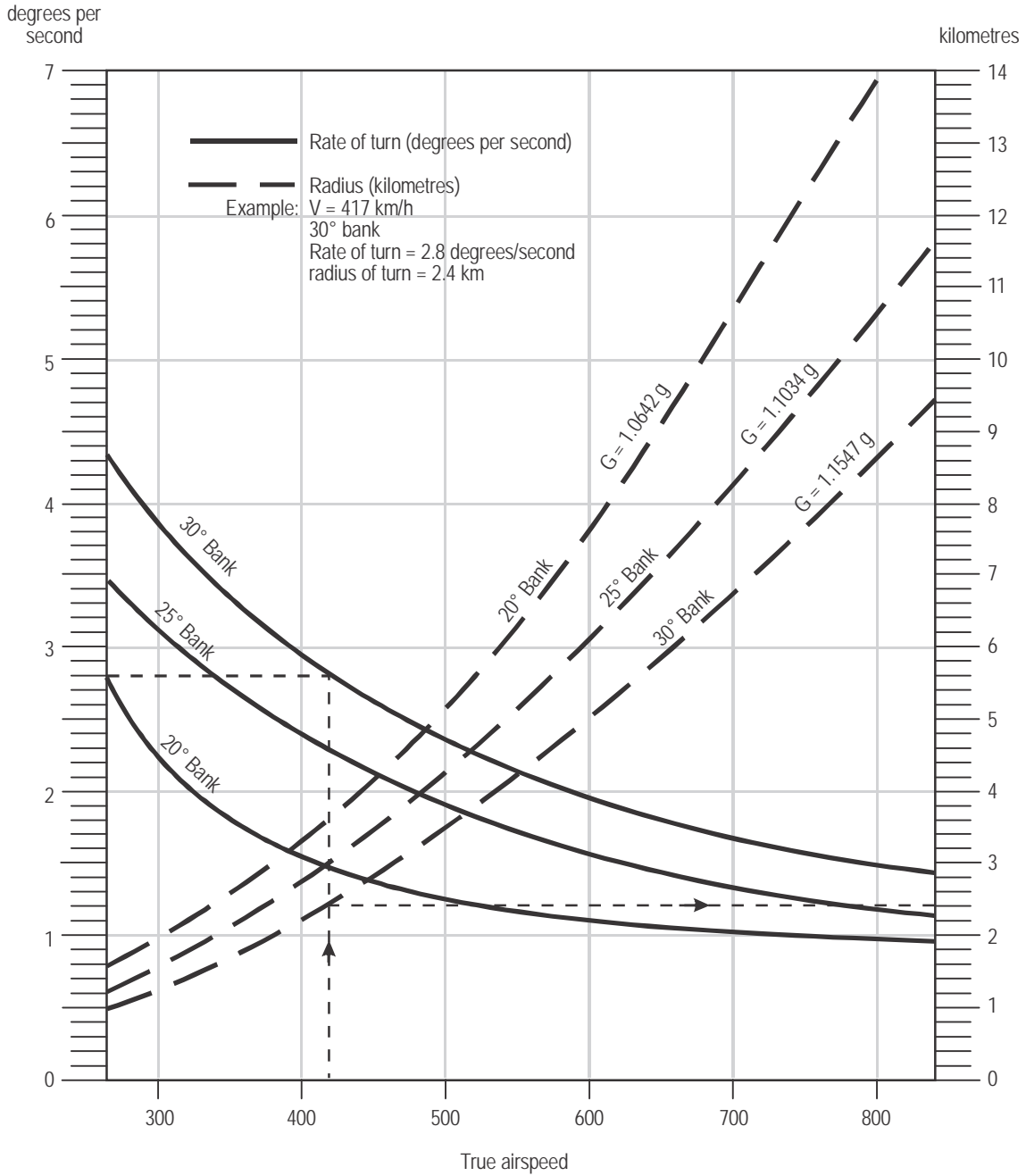

Figure II-4-1-App A-1. Angle of bank, rate of turn, radius of turn and g values at varying airspeeds (SI units)

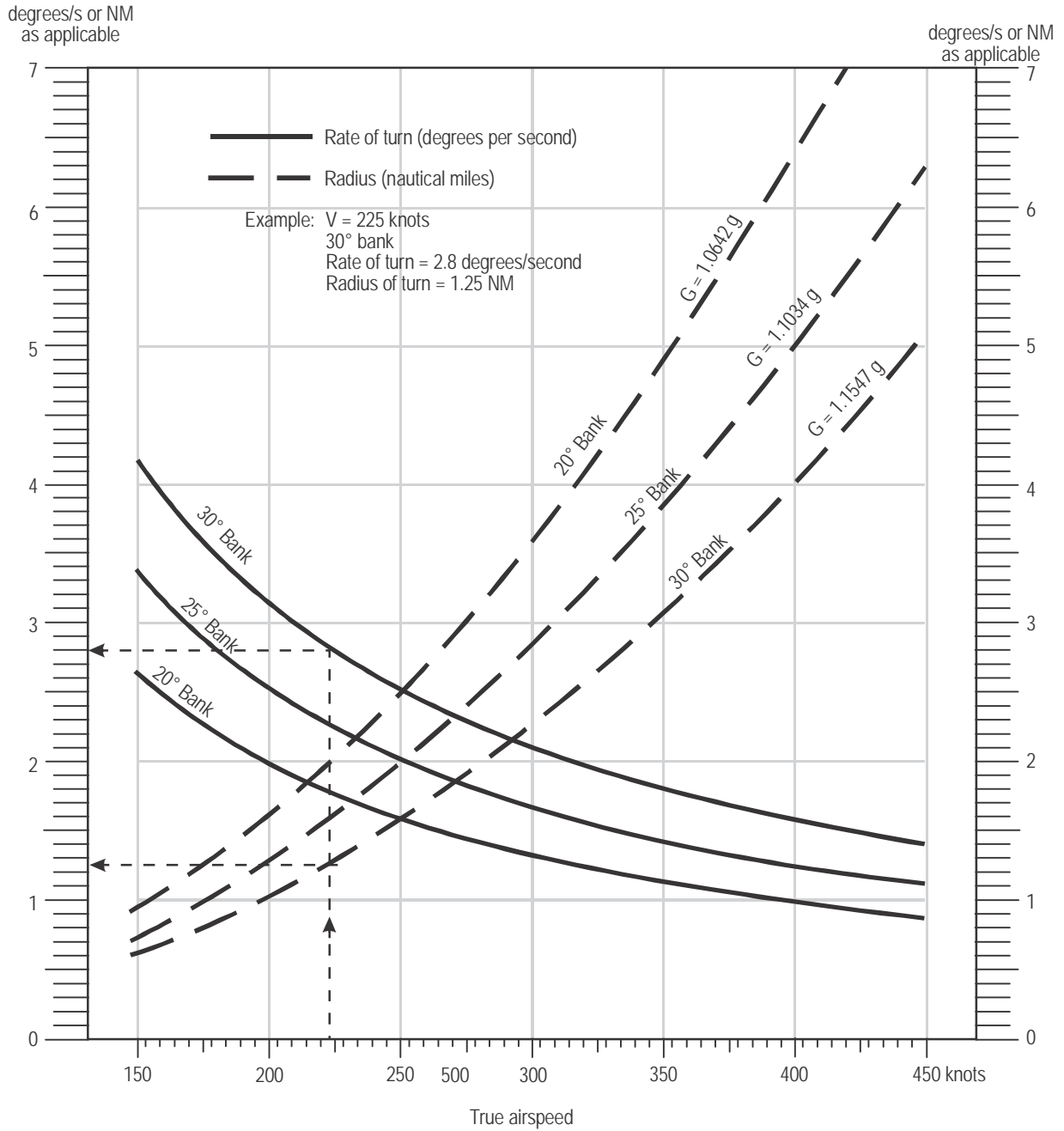

Figure II-4-1-App A-2. Angle of bank, rate of turn, radius of turn and g values at varying airspeeds (non-SI units)

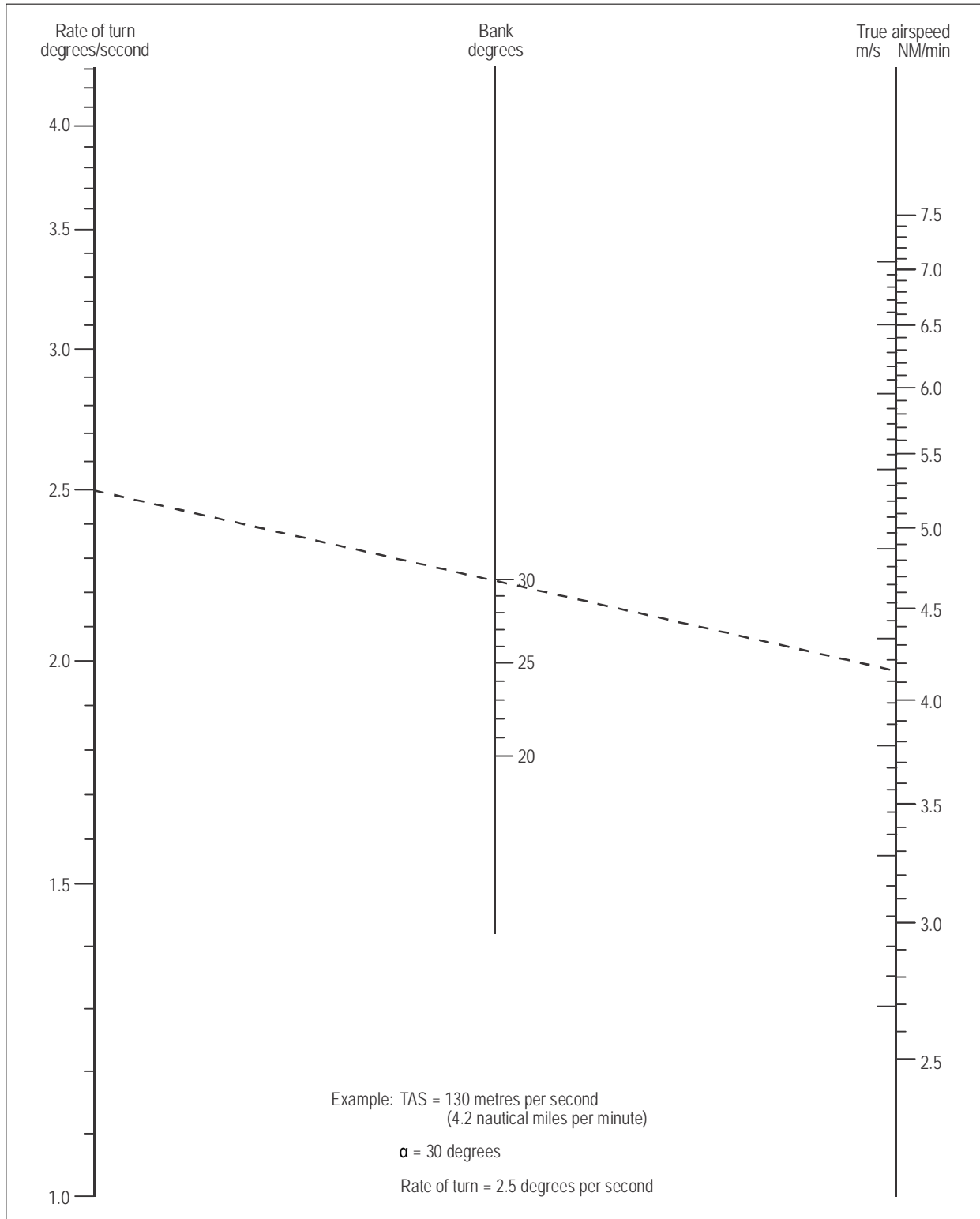
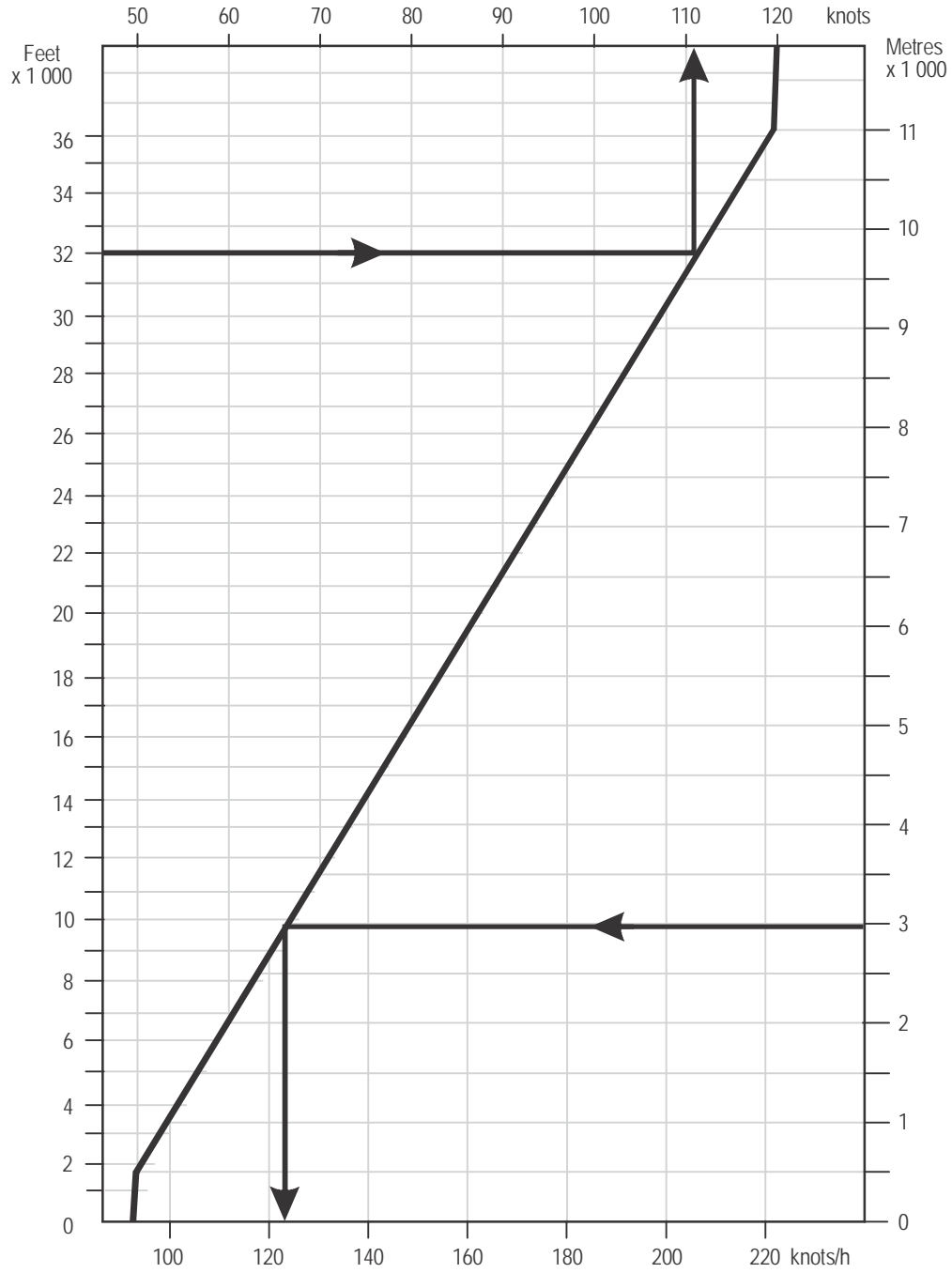

Figure II-4-1-App A-3. Rate of turn, in terms of bank and true airspeed



Example 1: 3 000 metres, 123 kilometres per hour

Example 2: 32 000 feet, 111 knots

Figure II-4-1-App A-4. Accountable wind vs. altitude

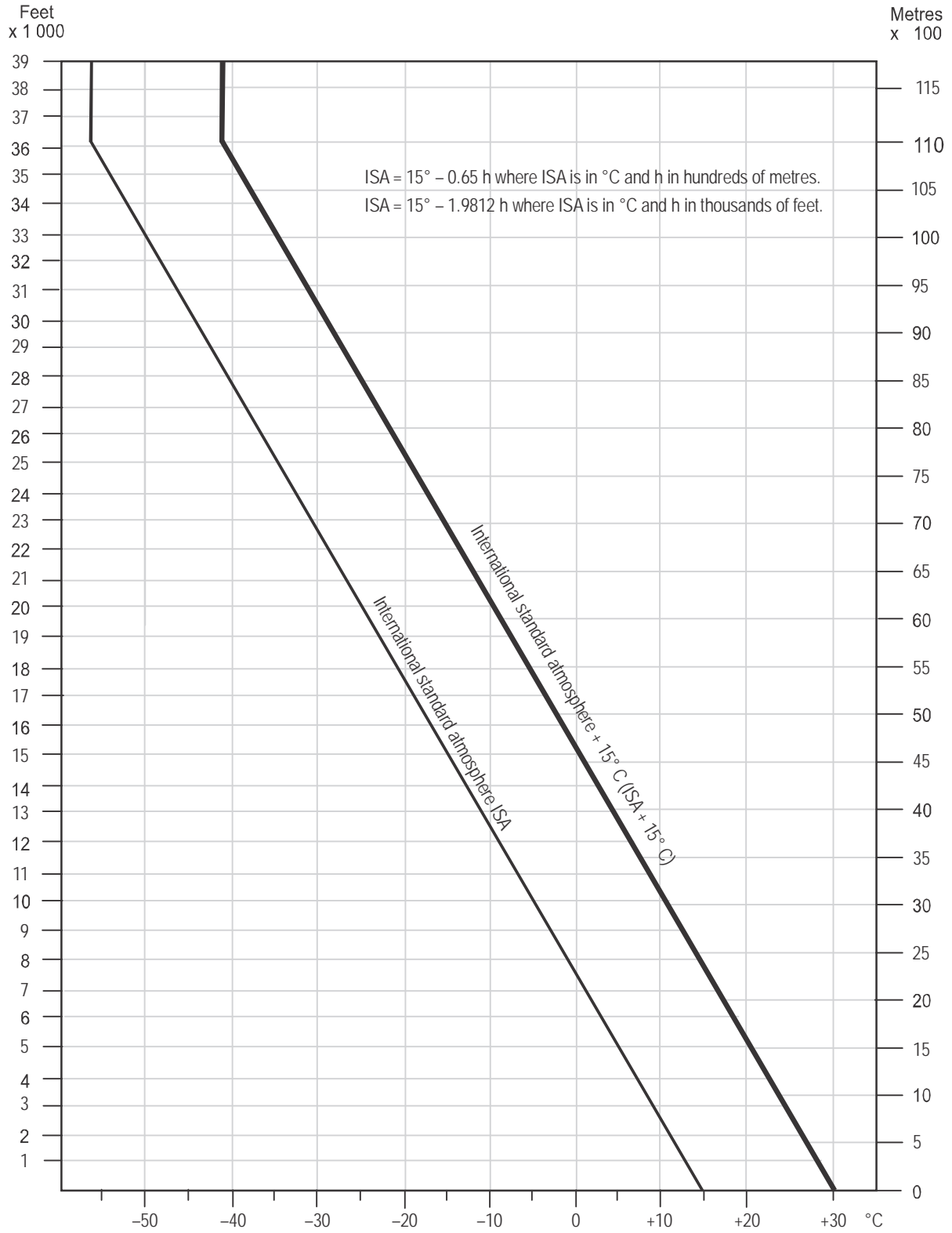
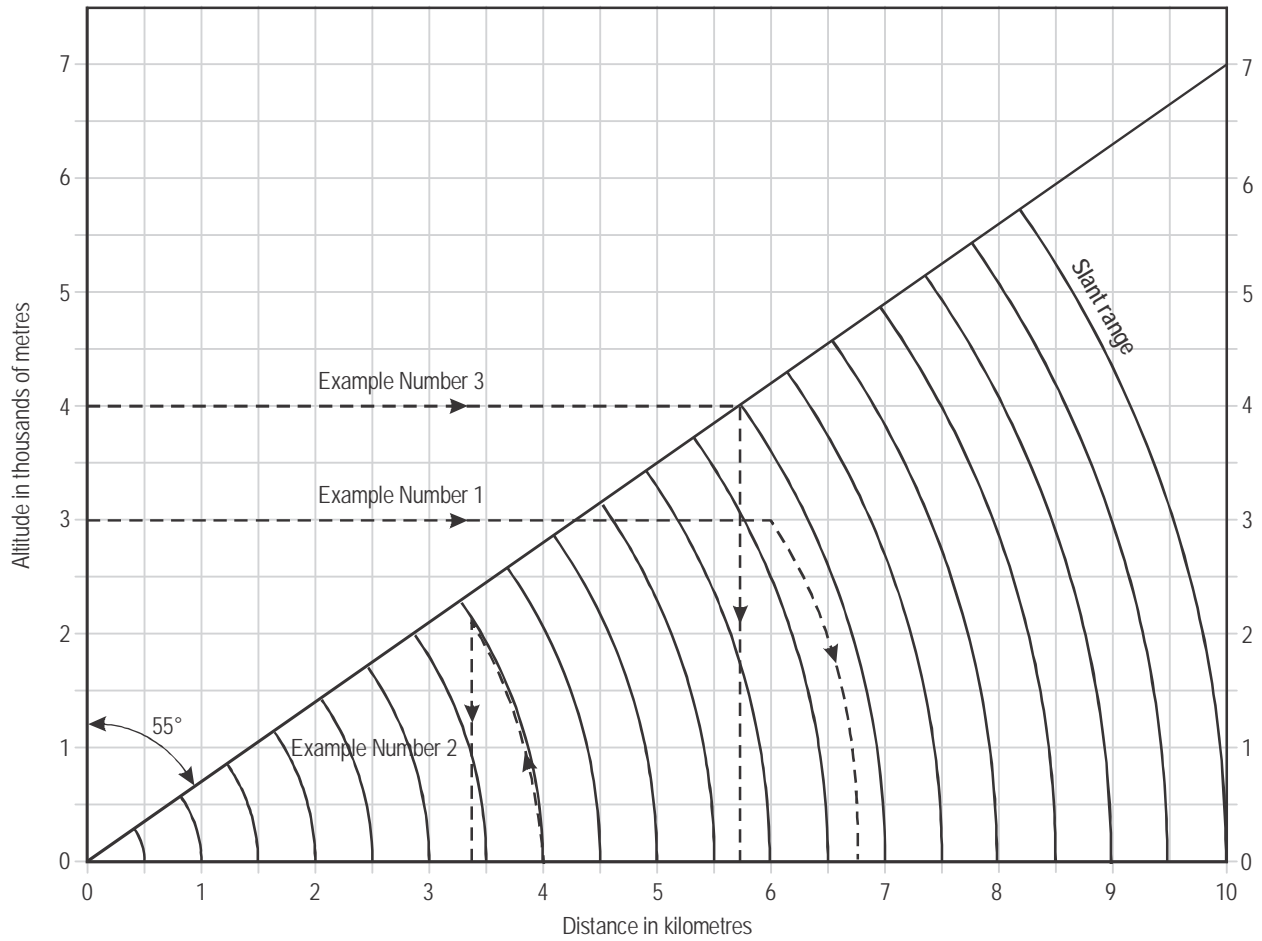

Figure II-4-1-App A-5. Temperature vs. altitude



For distances over 10 km and/or altitudes in excess of 7 000 m, multiply chart values by 10 (e.g. read as 1.7 km at 1 200 m or as 17 km at 12 000 m).

To determine slant range, extend altitude line to a point vertically above ground distance. Follow arc down to base line and read slant range (Example No. 1).

To determine ground distance, read slant range arc upward to selected altitude line. Follow vertically down to ground distance line (Example No. 2).

To determine minimum usable ground distance to VOR/DME fix, enter with the maximum altitude for the procedure. Ground distance is found vertically below intersection with diagonal (Example No. 3).

Figure II-4-1-App A-6. DME slant range vs. ground distance/ Minimum usable ground distance to a VOR/DME fix (SI units)

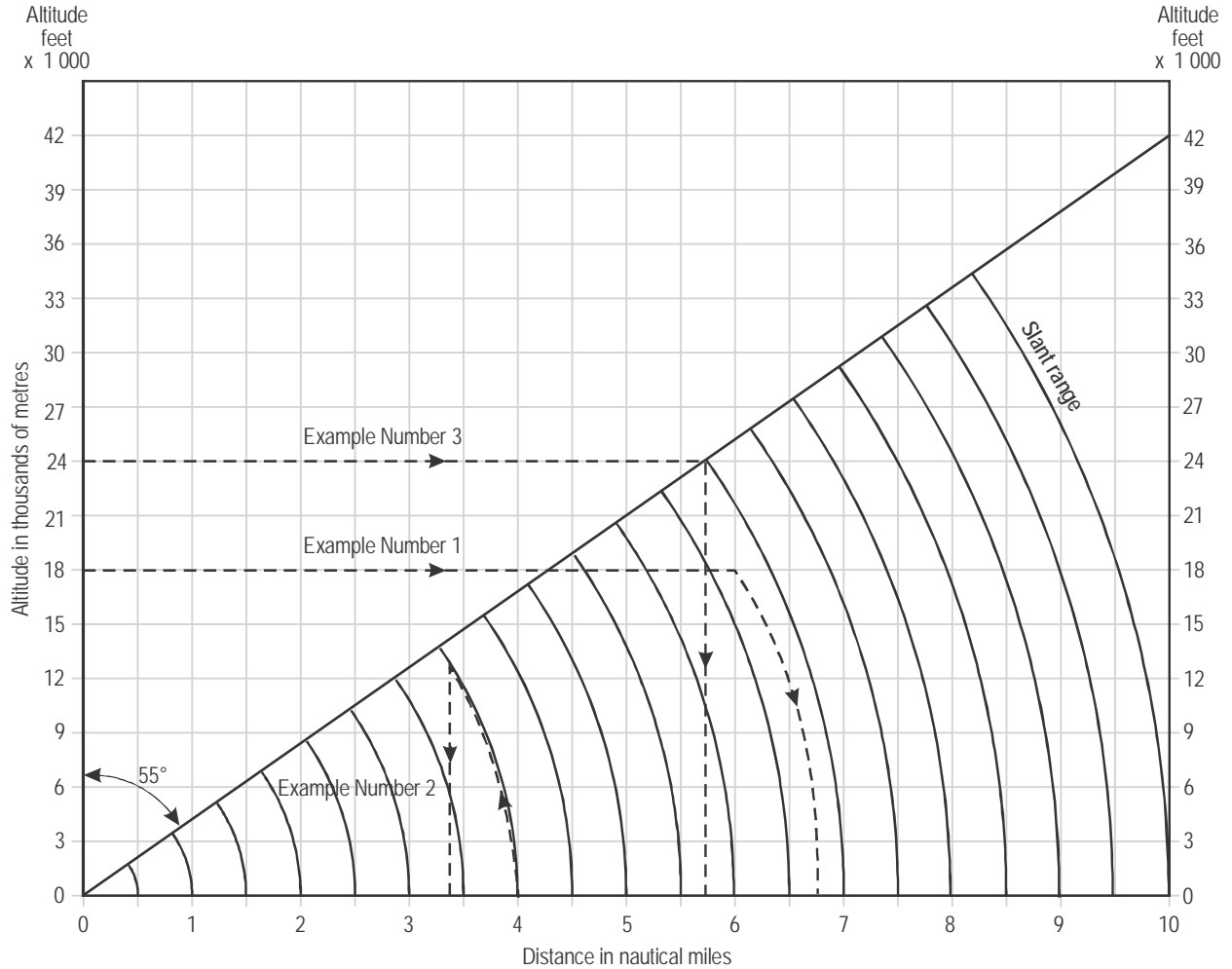

For distances over 10 miles and/or altitudes in excess of 35 000 ft, multiply chart values by 10 (e.g. read as 1 mile at 4 000 ft, or as 10 miles at 40 000 ft).

To determine slant range, extend altitude line to a point vertically above ground distance. Follow arc down to base line and read slant range (Example No. 1).

To determine ground distance, read slant range arc upward to selected altitude line. Follow vertically down to ground distance line (Example No. 2).

To determine minimum usable ground distance to VOR/DME fix, enter with the maximum altitude for the procedure. Ground distance is found vertically below intersection with diagonal (Example No. 3).

**Figure II-4-1-App A-7. DME slant range vs. ground distance/
Minimum usable ground distance to a VOR/DME fix (non-SI units)**

Appendix B to Chapter 1

DETERMINATION OF ADDITIONAL OBSTACLE CLEARANCE REQUIREMENTS FOR MINIMUM HOLDING LEVELS IN AREAS OF HIGH TERRAIN OR IN MOUNTAINOUS AREAS

1. When winds of 37 km/h (20 kt) or more move over precipitous terrain, lee or windward side turbulence can be created, varying in intensity. The degree of this turbulence is the result of many variables, such as wind speed, wind direction in relation to the terrain, atmospheric eddies, vortices, waves and other weather phenomena. One side effect of such turbulence is its associated effect on altimeter performance which can result in errors from a few to many feet depending upon the severity of the disturbance.

2. Criteria for establishing minimum holding altitudes in mountainous areas should take into consideration Bernoulli effect and precipitous terrain turbulence. A typical example which could produce Bernoulli effect, turbulence and associated altimeter error is shown in Figure II-4-1-App B-1.

3. Due to the many variables associated with such phenomena in mountainous areas it is impracticable to provide specific guidance that will cater to each situation. However, when establishing holding patterns in mountainous areas and when determining holding levels as a result of obstacle clearance considerations the following should be taken into account:

- a) areas characterized by precipitous terrain;
- b) weather phenomena peculiar to a particular area (including extreme down draughts); and
- c) phenomena conducive to steep local pressure gradients.

4. In areas where it is believed that the conditions described above may exist, or in areas where high altitude holding is required because of high terrain, the minimum holding altitude should be at a level which minimizes the aircraft's exposure to obstacles due to the possible effect on altimeter performance of the meteorological phenomena mentioned. This level will vary from a minimum of 300 m (984 ft) above obstructions within the holding area to 600 m (1 969 ft) or more whenever experience indicates a history of turbulence or other associated phenomena in the area including the associated buffer area.

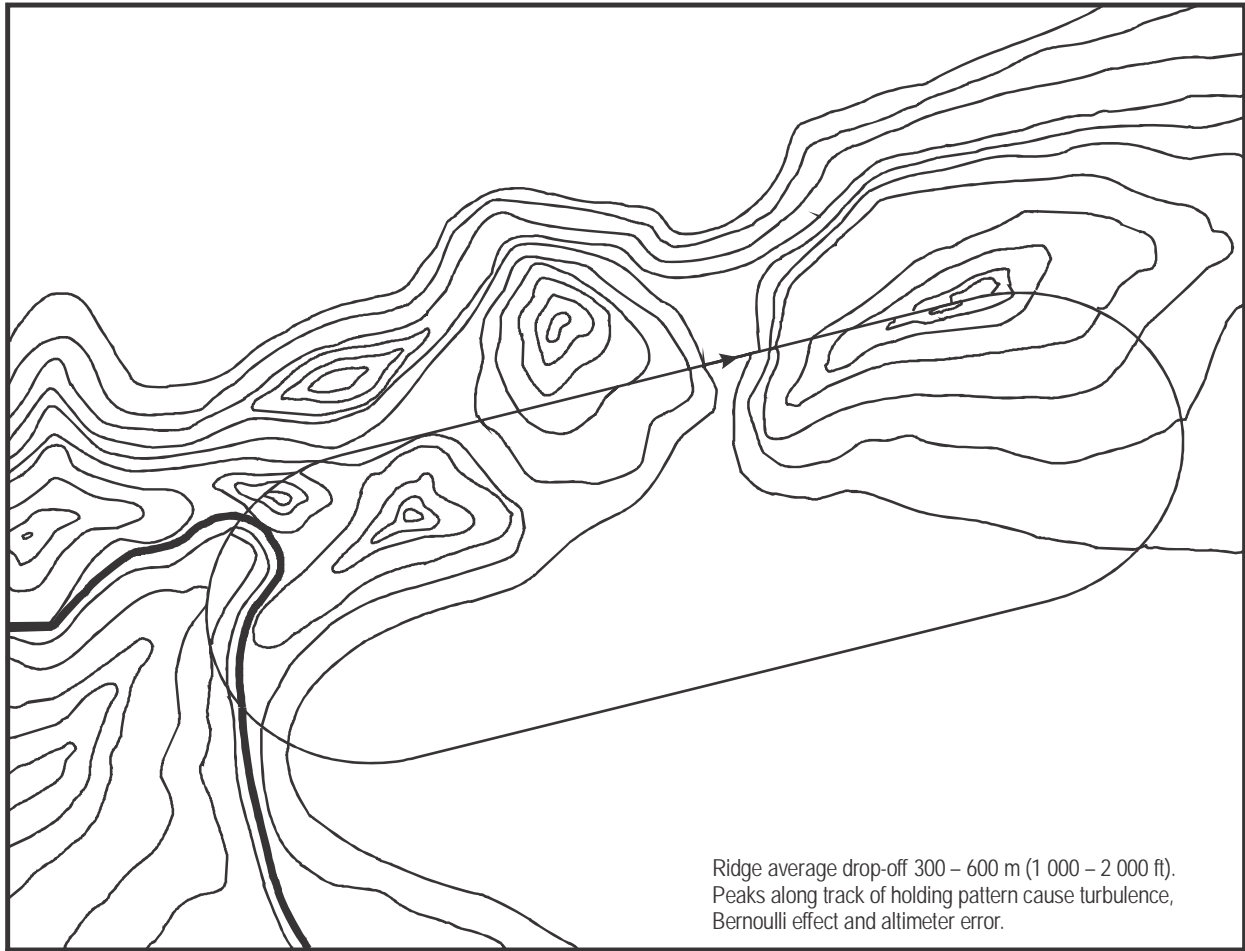

Figure II-4-1-App B-1

Attachment to Part II

ILS: BACKGROUND INFORMATION ON ILS OBSTACLE CLEARANCE AND ON AIRBORNE AND GROUND EQUIPMENT PERFORMANCE VALUES ASSOCIATED WITH CATEGORIES I AND II OBSTACLE ASSESSMENT SURFACES USED IN THE MATHEMATICAL MODEL

1. ILS OBSTACLE CLEARANCE

1.1 The ILS obstacle assessment surfaces differ in concept from the obstacle clearance surfaces defined for other instrument approach aids. In the calculation of minimum heights for other aids, the OCS are raised above the ground level until they are clear of obstacles, whereas the OAS remain fixed relative to the ground. The OAS remain fixed relative to threshold and are used to divide obstacles into two classes — accountable and non-accountable. Non-accountable obstacles are those which, although penetrating the basic Annex 14 surfaces, do not penetrate the OAS. No direct operating penalty is created by these obstacles provided their density is not considered excessive. In this respect the recommendations of Annex 14 (limiting penetrations of the defined surfaces) apply in the same way as with earlier ILS obstacle clearance surfaces. Recognizing that Annex 14 obstacle limitation surfaces are not always free of penetrations, a mathematical method (collision risk model) was developed to assess such obstacle penetrations in terms of risk. See OAS software (ICAO public website (www.icao.int) under “Publications”).

1.2 The collision risk model and the related obstacle assessment surfaces were designed to meet a level of operational safety of 1×10^{-7} per approach. This value was based loosely on the concept used by one State to determine mean time between failures for the ILS ground and airborne equipment. In that concept, the overall target level was set at one order better than the then current world accident rate (1×10^{-6}). This was arbitrarily divided between failures and performance, which should logically have resulted in a value of 5×10^{-8} for PANS-OPS. However, such precision was not matched by the accuracy of the data, and a ‘round number’ of 1×10^{-7} was considered more appropriate. It was also agreed that only items resulting in a change in probability exceeding one order should be treated as independent variables. The practical effect of a half-order change would have been a small increase in the dimensions of the iso-probability contours, plus an increase of about 2 m in the height loss element in both OAS and CRM. Further considerations included:

- a) additional protection was already provided by the Annex 14 surfaces;
- b) certification risk is measured against time and operations whereas the risk in approach is measured per sector, and must be factored by whether the flight involves an instrument approach and the percentage of occasions that the approach is in instrument conditions with weather conditions near minima; and
- c) to apportion risk for pilot/system performance at the sub-order level was cosmetic rather than practical.

It thus appeared appropriate to accept a target level of safety of 10^{-7} for the performance related criteria in PANS-OPS. Subsequently the 10^{-7} value was reviewed following a concern to align the target level of safety with that specified in various other aviation documents. However, a review of the accident statistics over the preceding 20 years led to the conclusion that the level of safety achieved by the precision instrument approach criteria exceeds the stated level by a large margin. It was noted that changing the target level of 1×10^{-7} associated with the 2007 version of the CRM would not achieve any measurable difference in the achieved safety.

1.3 The basic geometry of the OAS was defined by the approach surfaces. These were developed using a data-matched mathematical model. This model predicted aircraft position as a function of the main error-producing components of the total system and matched this against the results of a data collection programme. In the matching process equipment values appropriate to the sites in the collection programme were used in the model, and both equipment values and data were classed into Category I and Category II operations. Because the observed Category II autopilot performance was significantly better than that for Category II flight directors, the two were treated separately.

1.4 The data matched model produced lateral and vertical distributions at selected ranges in the final approach. These were combined to produce isoprobability contours at those ranges. Three factors defined the selection of an isoprobability contour for practical application. Firstly, the total risk summed over all ranges in the final approach was specified to lie within the overall safety target of 1×10^{-7} . Secondly, the isoprobability contours predicted the risk of being outside the contour at the range selected, whereas theoretical studies and data measurement suggested that the risk of being outside that contour at other ranges during the whole approach was about one order higher. Thirdly, it was recognized that the previous surfaces and any new surfaces should not be assumed to be solid walls. The existing provisions of Annex 14 were in no way reduced by the new criteria, and it was accepted that a probability of between 0.1 and 0.01 represented a realistic assessment of the risk of hitting an object between the Annex 14 surface and the OAS. These constraints led to the use of the isoprobability contour for 10^{-7} at the selected ranges as the basis for fitting practical surfaces. These surfaces, being planar, provided some additional safety.

1.5 The OAS were therefore constrained to contain the 10^{-7} isoprobability contours at all ranges. In addition, they were constrained to contain the minimum cross-sectional area; to protect aircraft within them climbing a 2.5 per cent gradient with a 20 per cent splay and to preclude those anomalies between categories of operation which would otherwise arise due to the use of simple planar surfaces.

1.6 An attempt was made to adjust the contours and surfaces to reflect the poorer performance theoretically possible according to one interpretation of Annex 10. The result was that the surfaces had to be expanded outside the previous PANS-OPS surfaces. The difference between the basic data-matched surfaces and those based on the poorer performance interpretation of Annex 10 was of the order of 10^{-2} in terms of probability. However, it was concluded that this increased risk was apparent rather than real and was due to the generous nature of both Annex 10 and the interpretation used. The practical surfaces were therefore based on the data-matched contours.

1.7 The Category I approach surfaces were extended to glide path intercept level, since the data showed a linear variation of approach performance with range. This was not the case with the Category II data, however. Because of this and because Category II operational performance constraints were often height related, the Category II surfaces were only extended up to 150 m (492 ft) above threshold.

1.8 The remaining surfaces were related to the previous PANS-OPS missed approach surface, there being little evidence upon which to base any change. However, to enable benefit to be obtained for aircraft having superior missed approach performance, provision was made for adjusting its gradient. To define the width of the missed approach surface, side planes were projected above and forward of the intersection of the approach surfaces and the plane of the glide path. These planes were adjusted to contain a 20 per cent splay combined with the gradient specified for the missed approach, and logically became the transitional surfaces linking approach and missed approach protection. They were not extended above 300 m (984 ft) for Cat I and 150 m (492 ft) for Cat II, the plan area covered at that level being considered adequate for even early missed approaches.

1.9 The Category I ground footprint usually lay within the Category II OAS for a given glide path angle and localizer threshold distance. This happened because the OAS construction method is intended to accommodate the variation within range of the standard deviation of predicted aircraft displacement from the nominal flight path (see Figure II-Att-2). The dimensions of the smaller footprint were then arbitrarily increased to be coincident with or enclosed by the original larger footprint. In practice, this is achieved by:

- a) setting dimension GD to 135 m in all cases; and
- b) basing $\tan \mu$ and $\tan \nu$ on the Category I values (fixing dimensions BC and EF, and $\tan Y$).

OAS Z surface

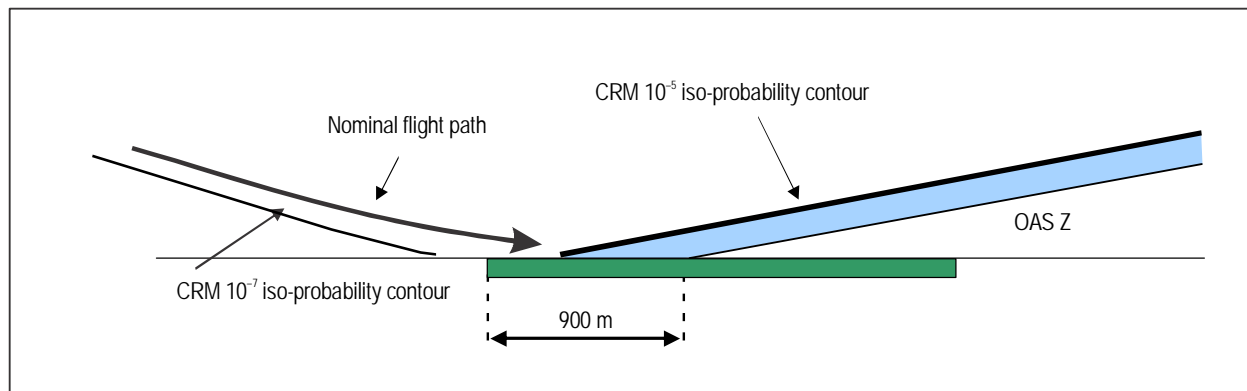

Figure II-Att-1. OAS Z surface below the mathematically modelled climbing portion of the missed approach (profile on centre line)

1.10 The slopes of the corresponding X planes are then recomputed as shown in Figure II-Att-2:

KL is the required tangent to the 7 800 m iso-probability contour
 KL and DH define the required approach surface.

Since KL and DH are coplanar, and DH lies in the horizontal plane while KL lies in a vertical plane at 7 800 m range, KL and DH shall intersect on the intersection of those two planes. Hence by projecting DH until it intersects the vertical plane at 7 800 m range, KL can be constructed. This exercise may be simplified by imagining the vertical plane at 7 800 m range folded into the horizontal plane.

The philosophy was modified to address similar discrepancies between corresponding sets of Category II (flight director) and Category II (autopilot) OAS. The dimensions of the ground footprint, the values of $\tan Y$ and $\tan W$, between runway threshold and 1 000 m range, remained the same. The overshoot performance of flight director and autopilot-equipped aircraft was expected to be very similar.

1.11 Missed approach obstacles were defined as those located beyond 900 m after threshold. In order to ensure simplicity a fixed value was chosen. No category-dependent values were used and the lower categories of aircraft with slower speeds were therefore over-protected. By that range (~ 900 m) all aircraft were considered to be climbing, and the margin above obstacles accounted for the fact that an increase in OCA/H also increased the distance available to climb prior to reaching a given obstacle. Due to this fixed longitudinal displacement of the OAS missed approach obstacle surface, the OAS method provides a greater vertical margin compared with the mathematical model and the CRM missed approach 10^{-5} contour (see Figure II-Att-1).

1.12 The partitioning of approach/missed approach obstacles by range was the simplest method to produce the desired operational penalty differential and was safe in all cases. However, the resulting OCA/H could be such that the “on glide path” OCA/H point was so far before the obstacle that it should be more correctly treated as a missed approach obstacle. Provision was therefore made for a more complex partitioning by defining approach/missed approach obstacles relative to a plane surface originating 900 m after threshold, and sloping upwards into the approach area parallel to the plane of the glide path.

1.13 The higher of the heights necessary for clearance of approach or missed approach obstacles was then taken as the obstacle clearance altitude/height to be applied in calculating operating minima as specified in Annex 6.

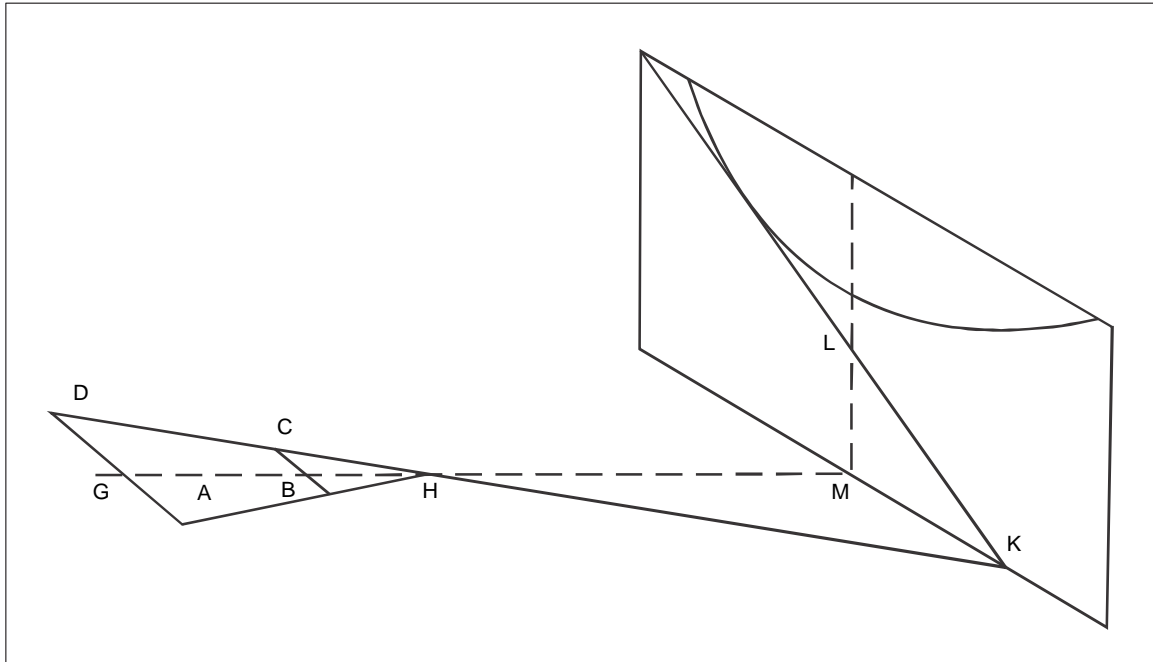

Figure II-Att-2. X-plane slope computation

1.14 The use of obstacle assessment surfaces in calculating OCA/H involved applying the same margin above all obstacles without regard to the location of obstacles relative to the flight path. To account for this, and to provide a means of assessing obstacle density, a “collision risk model” was developed. This was a computer programme containing data describing the spread of aircraft about their intended path, both in the approach and instrument missed approach. The programme used these distributions to evaluate the risk or collision probability associated with individual obstacles. To allow for the fact that only a proportion of the approaches results in a missed approach, the computed risk of each obstacle in the missed approach region was factored by a missed approach rate. Taking account of the variability in missed approach rate experienced over different periods of time and at different locations, one per cent was deemed to be representative of the general order of missed approach rates likely to be experienced and was used in the CRM. Risks associated with individual obstacles were then accumulated to produce a total risk for the complete set of obstacles of interest. This final value, representing a probability of collision per approach, could then be compared with a predetermined target level of safety. In this way the effects of operational adjustments (i.e. reduction in obstacle density, increase in OCA/H, change of GP angle) could be assessed on an objective basis.

1.15 Although the obstacle assessment surfaces can be considered as equivalent to the CRM iso-probability contours, there are some significant differences between the two. The set of surfaces matching the CRM iso-probability contours are simplified. This simplification results in conservatism. It is relevant that the procedure designer understands the differences between the two, as in some instances the resulting OCH may be unnecessarily high and result in unnecessary operational penalties.

1.16 The most significant differences are provided in Figure II-Att-3.

1.17 Figure II-Att-3 indicates that application of the OAS method results in a conservative OCH when obstacles are located between the CRM iso-probability contour and the OAS. There is a large difference in the width of the obstacle accountability areas between the two.

1.18 In addition, the CRM gives a gradual increase of the OCH, whereas the OAS has a binary effect: an obstacle penetrates or does not penetrate the surface. In the case of the CRM, the penetration has a gradual effect on the OCH. In the case of the OAS method, the obstacle may become the controlling obstacle and determine the OCH.

1.19 From a distance of approximately 3 000 m (depending on glide path angle) the CRM iso-probability contour bends upwards based on the assumed go-around manoeuvre. However, the associated OAS W surface continues at the same angle to threshold level. Thus, after approximately 3 000 m prior to threshold the OAS W surface becomes more conservative. As a consequence an obstacle penetrating the W surface may be a controlling obstacle when using the OAS method but be assessed as less than 1×10^{-7} in the CRM (see Figure II-Att-4).

OAS X surface

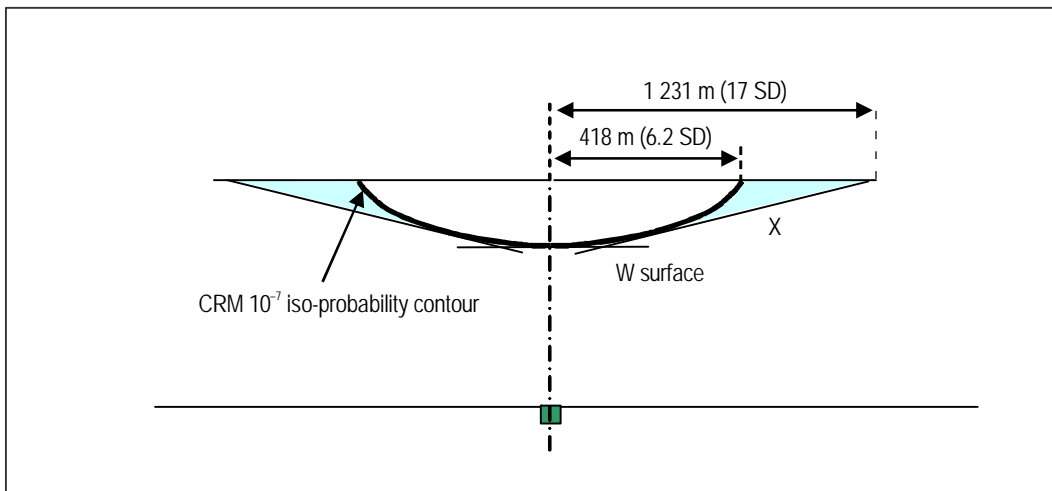

Figure II-Att-3. Cross section ILS CRM and OAS at 7 800 m standard conditions ILS CAT I, 3° glide path, distance threshold to LOC antenna 3 000 m

OAS W surface

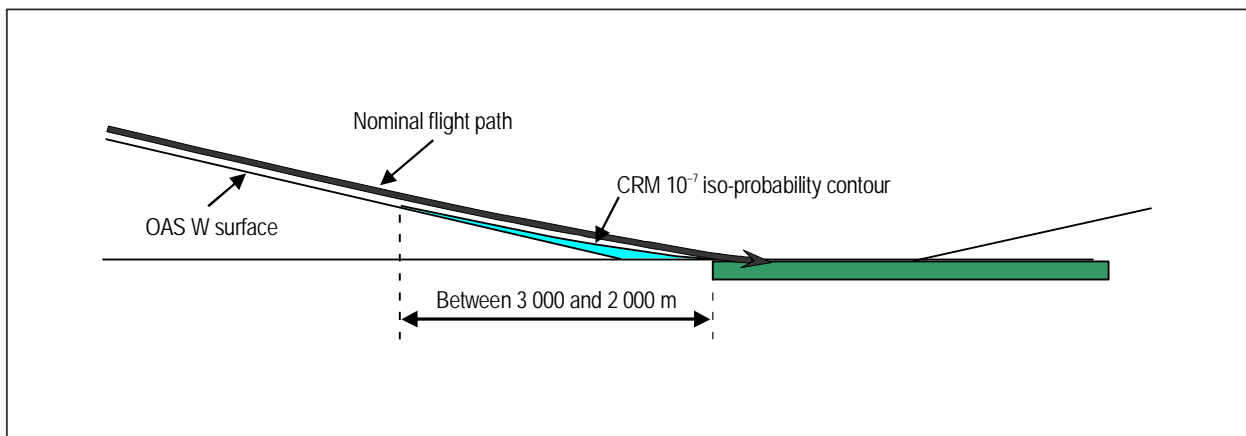

Figure II-Att-4. OAS W surface compared to the CRM flight path

2. AIRBORNE AND GROUND EQUIPMENT PERFORMANCE VALUES ASSOCIATED WITH CATEGORIES I AND II OBSTACLE ASSESSMENT SURFACES USED IN THE MATHEMATICAL MODEL

2.1 Airborne and ground equipment values used in the mathematical model

Details of the equipment (ground and air) values associated with the Categories I and II obstacle assessment surfaces are contained in Tables II-Att-1 and II-Att-2. This is background information only and cannot be used directly as a means of assessing changes in equipment performance. It represents the actual performance of the systems observed. It is included as a permanent record of the values used to match the model with the observed aircraft positions and to provide a complete reference for any future revision. Guidance material relating to equipment performance characteristics is contained in Annex 10, Volume I, Attachment C.

2.2 Beam holding

The approach surfaces were based on observed displacement data rather than on indicated deviations. However, when the mathematical model was matched to predict the actual approach path envelopes it was found that a good fit could be obtained by assuming that pilots attempt to limit indicated deviations at 75 μ A on both localizer and glide path. For the Cat I surfaces this was factored by the value 1.4.

2.3 Category II system failures

It has been assumed that failure of any part of the Category II system when the aircraft is below the relevant Category I missed approach level will be followed by the immediate initiation of a missed approach.

Table II-Att-1. Category I performance values used in the mathematical model
(See 2.1)

<i>Item</i>	<i>Distribution shape</i>	<i>Nominal value</i>	<i>Standard deviation</i>	<i>Truncation</i>	<i>Units</i>
Localizer					
Beam centring	normal	0	2.3	9.6	metres (m)
Beam sensitivity	normal	14.4×10^{-4}	6×10^{-5}	$\pm 2.448 \times 10^{-4}$	DDM/m
Receiver centring	double sided exponential	0	5	± 7 SD	microamps (μ A)
Receiver sensitivity	single exponential	968 (maximum)	32.3	484	μ A/DDM
Beam bends	normal	0	3 at 1 200 m 8.5 at 7 800 m	± 3.5 SD	μ A
Beam holding	double sided exponential	0	from data matching	mean 105 SD 15	μ A
Glide path					
Beam centring	normal	0	0.018	± 0.075	Unit θ (GP angle)
Beam sensitivity	normal	0.625	0.039	± 0.156	DDM/unit θ
Receiver centring	double sided exponential	0	5	± 7 SD	μ A
Receiver sensitivity	single exponential	859 (maximum)	28.6	430	μ A/DDM
Beam bends	normal	0	10	± 3 SD	μ A
Beam holding	double sided exponential	0	from data matching	mean 105 SD 15	μ A
This is background information only and cannot be used directly as a means of assessing changes in equipment performance.					

Table II-Att-2. Category II performance values used in the mathematical model
(See 2.1)

<i>Item</i>	<i>Distribution shape</i>	<i>Nominal value</i>	<i>Standard deviation</i>	<i>Truncation</i>	<i>Units</i>
Localizer					
Beam centring	normal	0	1.52	±7.62	metres (m)
Beam sensitivity	normal	14.4×10^{-4}	4.8×10^{-5}	$\pm 2.451 \times 10^{-4}$	DDM/m
Receiver centring	double sided exponential	0	3	±9 SD	microamps μ A)
Receiver sensitivity	single exponential	968 (maximum)	32.3	484	μ A/DDM
Beam bends	normal	0	2	±7	μ A
Beam holding	double sided exponential	0	from data matching	mean 75 SD 15	μ A
Glide path					
Beam centring	normal	0	0.015	±0.075	Unit θ (GP angle)
Beam sensitivity	normal	0.625	0.0344	±0.156	DDM/unit θ
Receiver centring	double sided exponential	0	5	±9 SD	μ A
Receiver sensitivity	single exponential	859 (maximum)	28.6	430	μ A/DDM
Beam bends	normal	0	8	±28	μ A
Beam holding	double sided exponential	0	from data matching	mean 75 SD 15	μ A
This is background information only and cannot be used directly as a means of assessing changes in equipment performance.					

**Procedures for
Air Navigation Services**

AIRCRAFT OPERATIONS

Part III

PERFORMANCE-BASED NAVIGATION PROCEDURES

Section 1

UNDERLYING PRINCIPLES

Chapter 1

RNAV CONCEPTS

1.1 GENERAL

1.1.1 The chapters in this section provide the components (XTT, ATT and area semi-width) which are required for the construction of instrument flight procedures, detailed in Sections 2 and 3. It should be noted that this does not apply to SBAS APV and GBAS, as the error components for such procedures are considered equivalent to the ILS approach, which are angular in nature.

1.1.2 Performance-based navigation (PBN) is defined as a type of area navigation (RNAV) in which the navigation performance requirements are prescribed in navigation specifications. A navigation specification is defined as a set of aircraft and aircrew requirements needed to support PBN operations within a defined airspace. RNAV as defined in PANS-OPS includes PBN and non-PBN applications, such as SBAS APV and GBAS.

Note.— ICAO is currently reviewing the possibility/need for developing navigation specifications for SBAS APV and GBAS under performance-based navigation.

1.1.3 There are two types of navigation specifications:

- a) *RNAV specification.* A navigation specification designation that does not include requirements for on-board performance monitoring and alerting.
- b) *RNP specification.* A navigation specification designation that includes requirements for on-board performance monitoring and alerting.

1.1.4 The ICAO *Performance-based Navigation (PBN) Manual* (Doc 9613 provides a detailed explanation of the PBN concept and guidance on how to implement PBN applications as well as navigation specifications for the following applications (see also Table III-1-1-1):

- a) *RNAV 10:* used to support RNAV operations in the en-route phase of flight to support longitudinal distance-based separation minima in oceanic or remote area airspace. Procedure design criteria have not been developed.
- b) *RNAV 5:* used to support RNAV operations in the en-route phase of flight for continental airspace. Obstacle clearance criteria are detailed in Part III, Section 1, Chapters 2, 3 and 4, and Section 3, Chapters 7 and 8.
- c) *RNAV 1 and 2:* used to support RNAV operations in the en-route phase of flight, on SIDs, on STARs and on approaches up to the FAF/FAP. Obstacle clearance criteria are detailed in Part III, Section 1, Chapters 2 and 3, and Section 3, Chapters 1, 2, 3, 7 and 8.

Note.— The criteria are also applicable to regional/national navigation specifications published prior to RNAV 1, such as P-RNAV.

- d) *RNP 4:* used to support RNAV operations in the en-route phase of flight to support longitudinal distance-based separation minima in oceanic or remote area airspace. Obstacle clearance criteria are detailed in Part III, Section 1, Chapter 2, and Section 3, Chapter 8.

- e) *RNP 2*: used to support RNP operations in the en-route phase of flight in oceanic, remote area and continental airspace. Obstacle clearance criteria are detailed in Part III, Section 1, Chapter 2, and Section 3, Chapter 8.
- f) *RNP 1*: used to support RNP operations on SIDs, on STARs and on approaches up to the FAF/FAP with no, or limited, ATS surveillance and with low to medium density traffic. Obstacle clearance criteria are detailed in Part III, Section 1, Chapter 2, and Section 3, Chapters 1, 2, 7 and 8.
- g) *Advanced RNP (ARNP)*: used to support RNP operations in en-route continental airspace and on SIDs, STARs and approach procedures. ARNP requirements include the following values for navigation accuracy: 0.3 NM in final approach; 1 or 2 NM in en-route continental; and navigational accuracy of 1 NM in SIDs, STARs, initial/intermediate approaches and missed approaches. Optional requirements include applications for oceanic/remote airspace and an incremental option which allows any navigational accuracy value between 1.0 NM and 0.3 NM, in 0.1NM increments, in all terminal flight phases outside final approach. Obstacle clearance criteria are detailed in Part III, Section 1, Chapter 2, and Section 3, Chapters 1, 2, 3, 4, 7 and 8.
- h) *RNP 0.3*: used to support helicopter RNP operations in all phases of flight except final approach. Obstacle clearance criteria are detailed in Part III, Section 1, Chapter 2 and Part IV.
- i) *RNP APCH*: used to support RNP approach operations to LNAV, LNAV/VNAV, LP and LPV minima. Obstacle clearance criteria are detailed in Part III, Section 1, Chapter 2, and Section 3, Chapters 2, 3, 4, 5 and 7.
- j) *RNP AR APCH*: used to support RNP approach operations, including the final approach segment, which consist of straight and/or fixed radius segments, with navigation accuracies equal to or less than 0.3 NM on final and 1 NM on the other approach segments.

Note 1.— The criteria to develop RNP AR approach procedures are detailed in the Required Navigation Performance Authorization Required (RNP AR) Procedure Design Manual (Doc 9905).

Note 2.— The navigation specifications, together with associated appendices and attachments, in the ICAO Performance-based Navigation (PBN) Manual (Doc 9613) also contain details of specific navigation functions that may be optional or mandatory, depending upon the navigation specification:

- a) *All navigation specifications intended for terminal and approach procedures require the ability to execute leg transitions and maintain tracks consistent with specific ARINC 424 path terminators. In particular, the ability to fly constant radius turns in terminal airspace, using the RF path terminator, is addressed in the RNP AR APCH navigation specification and in Doc 9613, Volume II, Part C, Appendix 1. The RF path terminator functionality is required in the ARNP navigation specification and is an optional function in the RNP 1, RNP 0.3 and RNP APCH navigation specifications. Its application in RNP AR APCH operations is addressed in Doc 9905.*
- b) *The ability to fly constant radius turns in the en-route phase of flight is addressed in Doc 9613, Volume II, Part C, Appendix 2. Fixed radius transitions (FRT) are associated with individual waypoints on an en-route structure and may be used in ARNP and RNP 2 applications.*

Note.— Guidance on how to employ FRT is still being developed and once it is mature, design criteria for FRT will be included in PANS-OPS.

- c) *The use of barometric altitude and RNAV information in the definition of vertical flight paths and vertical guidance in relation to a path, known as Baro-VNAV, is addressed in Doc 9613, Volume II, Attachment A.*

Table III-1-1-1. Navigation specification per flight phase

	<i>Flight Phase</i>							
	<i>Oceanic/Remote</i>	<i>En-route</i>	<i>Arrival</i>	<i>Approach</i>				<i>Departure</i>
				<i>Initial</i>	<i>Intermediate</i>	<i>Final</i>	<i>Missed¹</i>	
RNAV 10	10							
RNAV 5		5	5 ²					
RNP 4	4							
RNP 2	2	2						
RNAV 2		2	2					2
Advanced RNP ³	2	2 or 1	1 – 0.3	1 - 0.3	1 - 0.3	0.3	1 - 0.3	1 - 0.3
RNP 1			1	1	1		1	1
RNAV 1		1	1	1	1		1	1
RNP 0.3 (Cat H)		0.3	0.3	0.3	0.3		0.3	0.3
RNP APCH (Part A) ⁴				1	1	0.3	1	
RNP APCH (Part B) ⁴				1	1	Angular	1 or 0.3 (initial straight MISAP)	
RNP AR APCH				1-0.1	1-0.1	0.3-0.1	1-0.1	

Notes:

- RNP requirements do not apply to initial and intermediate missed approach segments.*
- RNAV 5 may be used for initial parts of STARs outside 30 NM from the ARP.*
- Advanced RNP core requirements are limited to RNP 1 in all flight phases except final approach (RNP 0.3) and RNP 2 in oceanic/remote and en-route continental. A scalability option will allow accuracy values between 0.3 and 1.0, in 0.1 NM increments, in all flight phases except oceanic/remote/en-route continental (RNP 1 and RNP 2) and final approach (RNP 0.3).*
- Part A and B refer to the Performance-based Navigation (PBN) Manual (Doc 9613), Volume II, Part C, Chapter 5, Part A — RNP APCH operations down to LNAV and LNAV/VNAV minima and Part B — RNP APCH operations down to LP and LPV minima, respectively.”*

1.2 FLIGHT TECHNICAL ERROR

The 95 per cent FTE values from which the design criteria for PBN applications have been derived are detailed in Table III-1-1-2 and are based upon the following formulae:

For RNAV, FTE = ½ required navigation accuracy

For RNP ≥ 0.5, FTE = ½ RNP

For RNP ≤ 0.5, FTE = 463 m (0.25 NM)

Table III-1-1-2. FTE as a function of PBN navigation specification

<i>Phase of flight</i>	<i>FTE (95 per cent) Specific to required navigation specification</i>
En route (greater than or equal to 56 km (30 NM) from departure or destination ARP)	RNAV 5 – 4 630 m (2.5 NM) RNP 4 – 3 704 m (2 NM) RNAV 2 – 1 852 m (1 NM) RNAV 1 – 926 m (0.5 NM) RNP-1 – 926 m (0.5 NM)
Terminal (SIDs, STARs, initial and intermediate approaches less than 56 km (30 NM) of the ARP)	RNAV 2 – 1 852 m (1 NM) RNAV 1 – 926 m (0.5 NM) RNP-1 – 926 m (0.5 NM) RNP APCH – 926 m (0.5 NM)
Final approach	RNP APCH – 463 m (0.25 NM)
Missed approach	RNP APCH – 926 m (0.5 NM)

Note.— The FTE value for RNAV 5 is that specified in the navigation specifications in the Performance-based Navigation Manual (Doc 9613) and may be considered to be conservative in the context of the demonstrable performance.

1.3 MAGNETIC BEARING ON A PBN (RNAV OR RNP) ROUTE SEGMENT

Magnetic bearing on an PBN route segment. The magnetic bearing for a PBN route segment shall be based on the true course and the magnetic variation at the significant point at origin of the PBN route segment. The magnetic bearing shall be charted to the nearest degree. When a PBN route overlays an existing airway (joint conventional and PBN route) the VOR radial or the NDB magnetic bearing shall be charted.

1.4 BUFFER VALUES

1.4.1 The RNAV and RNP cross-track tolerance values are derived from the NSE and FTE. They are both treated as though they are Gaussian and are determined by the RSS of these two errors. (For GNSS-based RNP systems, the NSE is small and the FTE is the dominant component.) However, it is known that the distributions which include, inter alia, blunder errors, are not truly Gaussian and the tails of the distributions cannot be accurately determined without an extensive data set, which is not available. These tails are therefore accounted for in the procedure design criteria for all

PBN applications except RNP AR by an additional “buffer value”, based upon the aircraft characteristics (speed, manoeuvrability, etc.) and the phase of flight (pilot reaction time, time of exposure, etc.), to address excursions beyond a 3 standard deviation (3σ) value.

1.4.2 The buffer values (BV) in Table III-1-1-3 are applied in all PBN applications except RNP AR:

Table III-1-1-3. Buffer values

<i>Phase of flight</i>	<i>BV for CAT A–E</i>	<i>BV for CAT H</i>
En-route, SIDs and STARs (greater than or equal to 56 km (30 NM) from departure or destination ARP)	3 704 m (2.0 NM)	1 852 m (1.0 NM)
Terminal (STARs, initial and intermediate approaches less than 56 km (30 NM) of the ARP; and SIDs and missed approaches less than 56 km (30 NM) of the ARP but more than 28 km (15 NM) from the ARP)	1 852 m (1.0 NM)	1 296 m (0.7 NM)
Final approach	926 m (0.5 NM)	648 m (0.35 NM)
Missed approaches and SIDs up to 28 km (15 NM) from the ARP	926 m (0.5 NM)	648 m (0.35 NM)

1.5 OBSTACLE CLEARANCE AREA

1.5.1 Area semi-width

1.5.1.1 The $\frac{1}{2}$ A/W of the obstacle clearance area in all RNAV and RNP applications (except RNP AR) is based upon the following:

$$\frac{1}{2} A/W = 1.5 * XTT + BV$$

Where XTT is the 2σ cross-track tolerance value (known as TSE) and BV is the “buffer value”, detailed in Table III-1-1-2.

1.5.1.2 More than one navaid type can be used on a procedure (e.g. DME/DME and GNSS for RNAV 1), the XTT, ATT and area semi-width shall be calculated for each specific navaid type and the obstacle clearance shall be based on the greater of these values.

1.5.2 Secondary areas

The principle of secondary areas is applied on all RNAV legs where track guidance is available. Secondary areas may also be used on legs which are coded for heading mode (VA, VI, VM path terminators) provided that the whole area splays out at 15° to take account of wind effect.

1.5.3 Merging segments of different widths

Larger area semi width values are merged, at 30° to the nominal track, to achieve smaller area semi width values at one ATT after the designated waypoint (use ATT value associated to the succeeding segment). Smaller semi-area width values are splayed, at 15° to the nominal track, to larger area semi-width values from one ATT prior to the designated waypoint. This is illustrated in Figure III-1-1-1. The merging and splaying at flight phase interfaces is addressed in paragraph 1.5.4.

1.5.4 Merging areas at flight phase interfaces

1.5.4.1 For arrivals and approaches, at the point where the flight phase and/or XTT changes, the area width is defined using the buffer value for the preceding phase and the XTT value for the subsequent phase. When the area width of the subsequent segment is smaller than the area width of the preceding one, the merge is achieved using a line at 30° to the nominal track anchored by the area width at the point of change (e.g. IF, FAF). The outer edge of the primary area delineates half the total area. This is illustrated in Figure III-1-1-2, for FAF change, where:

Intermediate segment $\frac{1}{2} A/W = 1.5 * XTT_{IF} + \text{terminal buffer value}$

FAF $\frac{1}{2} A/W = 1.5 * XTT_{FAF} + \text{terminal buffer value}$

Final approach segment $\frac{1}{2} A/W = 1.5 * XTT_{MAPt} + \text{final approach buffer value}$

1.5.4.2 The same principle applies at the interface between the en-route phase and the initial approach phase.

1.5.4.3 When the area width of the subsequent segment is larger than the area width of the preceding one, the merge is achieved by a 15° splay from the area width of the preceding segment at the earliest limit of the point where the flight phase and/or XTT changes. The outer edge of the primary area delineates half the total area. This is illustrated in Figure III-1-1-3.

1.6 FIXES

1.6.1 Fix identification

The fixes used are those in the general criteria. Each fix shall be determined as a waypoint as specified in Annex 15.

1.6.2 Stepdown fixes

Criteria contained in Part I, Section 2, Chapter 2, 2.7.3, “Stepdown fix” and 2.7.4, “Obstacle close to a final approach fix or stepdown fix” relative to stepdown fixes apply. The SDF location shall not be considered for the calculation of the lateral protection area.

1.6.3 Additional fixes within a straight segment

To allow implementation of specific constraints (e.g. a speed restriction, a change of altitude or a reporting point for ATC purposes) some waypoints that are neither turning waypoints nor specified as IAF, IF, FAF or MAPt may be added within a straight segment. Nevertheless, as the limitation of waypoint number is essential for various reasons (e.g. flyability, pilot workload, navigation database size), the following needs to be taken into account:

- a) The least number of waypoints required should be used in developing procedures. Unless it is necessary and irrespective of the phase of flight, no more than two additional waypoints should be specified within a straight segment. These additional waypoints are not considered for the calculation of the lateral protection area and are defined as fly-by waypoints; and
- b) Altitude changes and speed restrictions shall only be applied when operational benefits are expected.

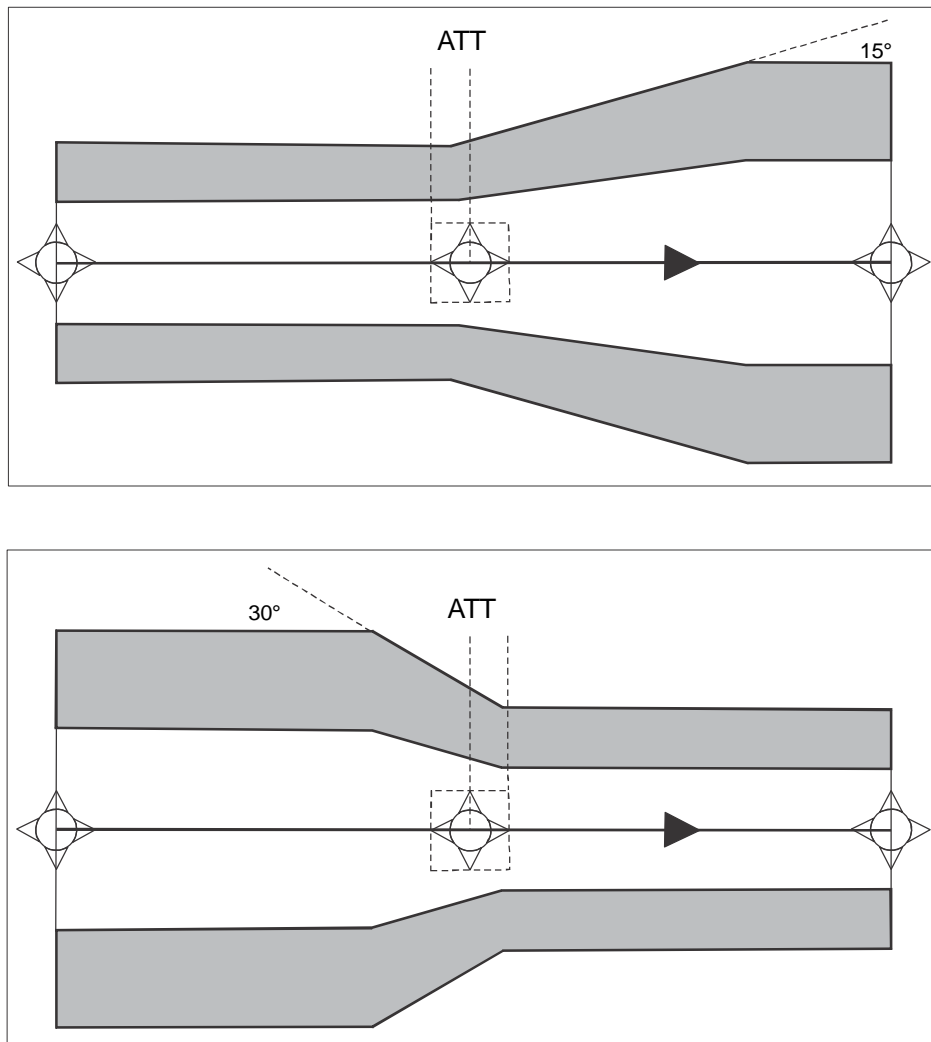

Figure III-1-1-1. Merging segments of different widths

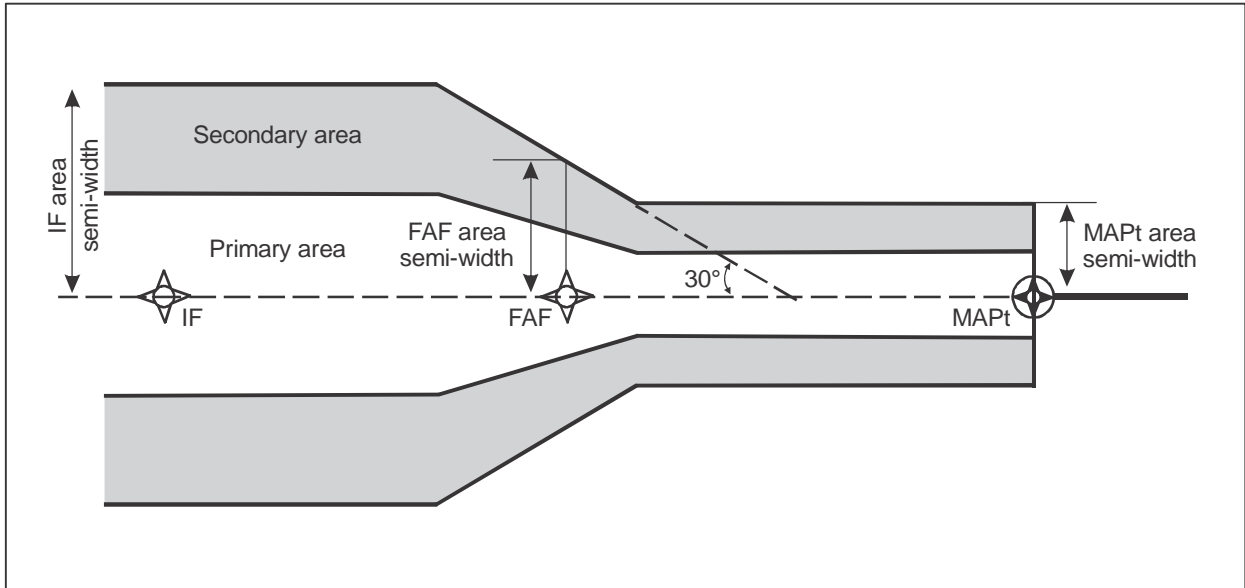

Figure III-1-1-2. Merging at phase-of-flight interfaces — FAF

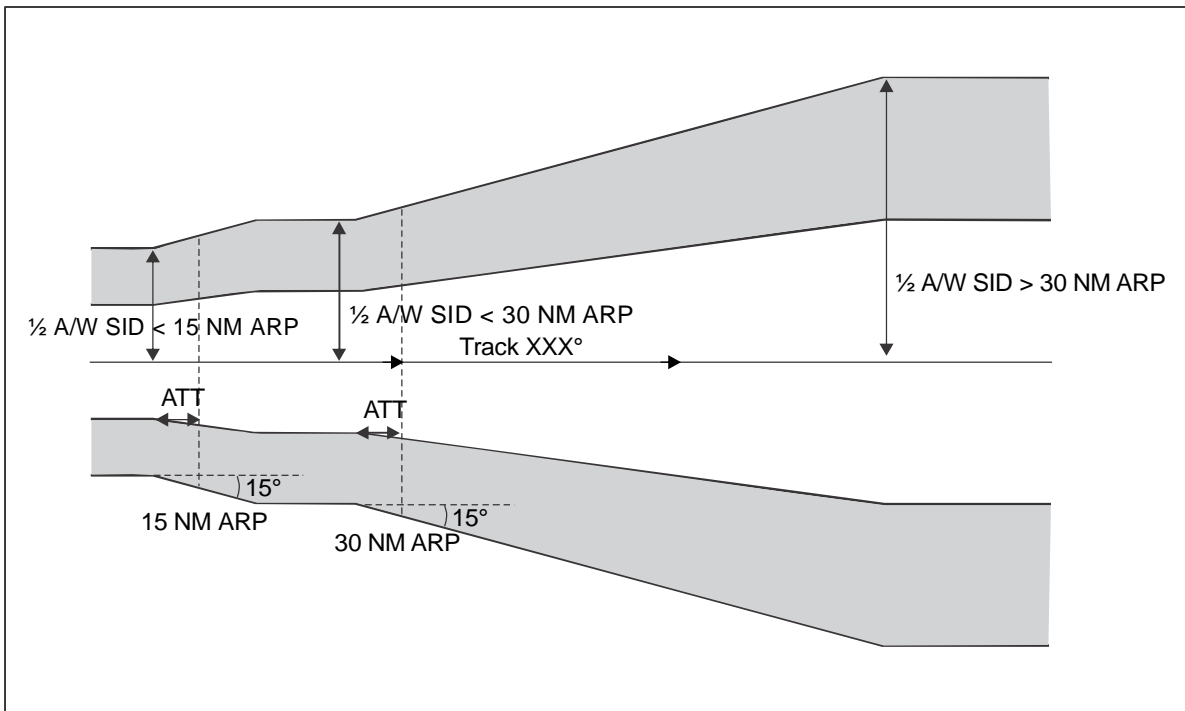

Figure III-1-1-3. Merging at phase-of-flight interfaces — departures

Chapter 2

GNSS RNAV

2.1 GENERAL

2.1.1 This chapter provides the cross-track and along-track parameters for GNSS used as input to the procedure construction criteria provided in Section 3 of this part. GNSS positioning is applicable to the following navigation specifications:

- a) RNAV 5;
- b) RNAV 2;
- c) RNAV 1;
- d) RNP 4;
- e) RNP 2;
- f) RNP-1;
- g) Advanced RNP;
- h) RNP 0.3; and
- i) RNP APCH (except for LP/LPV minima).

2.2 XTT, ATT AND AREA SEMI-WIDTH

2.2.1 *XTT and ATT for RNP navigation specifications.* The total system error (TSE) is dependent upon position estimation error (SIS error and airborne receiver error), path definition error, display error and flight technical error. The RNP navigation specifications define lateral TSE values as follows:

- a) *RNP 4.* The lateral TSE and the along-track error will not exceed ± 7.4 km (4 NM) for at least 95 per cent of the total flight time.
- b) *RNP 2.* The lateral TSE and the along-track error will not exceed ± 3.7 km (2.0 NM) for at least 95 per cent of the total flight time.
- c) *RNP-1.* The lateral TSE and the along-track error will not exceed ± 1.9 km (1 NM) for at least 95 per cent of the total flight time.
- d) *Advanced RNP.* The lateral TSE and the along-track error will not exceed the applicable accuracy for the phase of flight:

- oceanic/remote: ± 3.7 km (2.0 NM)
- continental en route: ± 3.7 km (2.0 NM) or ± 1.9 km (1 NM)
- departure, arrival, initial, intermediate, missed approach: $\pm (0.56$ km (0.3 NM) to 1.9 km (1 NM)) with a 0.19 km (0.1 NM) increment
- final approach: ± 0.56 km (0.3 NM)

for at least 95 per cent of the total flight time.

- e) *RNP 0.3*. The lateral TSE and the along-track error will not exceed ± 0.56 km (0.3 NM) for at least 95 per cent of the total flight time.
- f) *RNP APCH (LNAV and LNAV/VNAV only)*. The lateral TSE and the along-track error will not exceed ± 1.9 km (1 NM) 95 per cent of the total flight time during the initial and intermediate segments of the approach and during the missed approach, where the missed approach is predicated upon an RNAV requirement. The lateral TSE and the along-track error will not exceed ± 0.56 km (0.3 NM) 95 per cent of the total flight time during the final approach.

Note.— The final approach and missed approach segment of RNP APCH down to LP or LPV minima is addressed in Part III, Section 3, Chapter 5.

The TSE is used to define the XTT and ATT values as follows:

$$\text{XTT} = \text{TSE}$$

$$\text{ATT} = 0.8 * \text{TSE}$$

2.2.1.1 RNP APCH criteria shall only be applied within 56 km (30 NM) of the destination ARP. Outside this distance, either the RNAV 1 or RNP-1 criteria should be applied.

2.2.2 *XTT and ATT for RNAV navigation specifications*. Where the FTE in an RNAV navigation specification exceeds the integrity monitoring alarm limit (IMAL) of the GNSS receiver, the XTT is based upon the standard root sum square of the TSE ($\text{TSE} = \text{NSE} + \text{FTE} + \text{ST}$, where ST is equal to 0.25 NM). Where the FTE is equal to, or less than, the IMAL, the XTT is based upon the IMAL. This is illustrated in the following table:

<i>Phase of flight</i>	<i>Navigation specification</i>	<i>XTT</i>
En-route and terminal (>56 km (30 NM) from ARP)	RNAV 5	4.65 km (2.51 NM)
En-route and terminal (>56 km (30 NM) from ARP)	RNAV 1 and 2	3 704 m (2.00 NM)
Terminal (<56 km (30 NM) from ARP) to the IAF	RNAV 1 and 2	1 852 m (1.00 NM)

$$\text{ATT} = 0.8 * \text{XTT}$$

2.2.3 Area semi-width

2.2.3.1 Area semi-width ($\frac{1}{2}$ A/W) at a waypoint is determined by the following equation:

$$\frac{1}{2} A/W = XTT \times 1.5 + BV$$

where:

1.5 XTT corresponds to a 3σ lateral TSE value

BV = buffer value (for values see Table III-1-1-2).

2.2.3.2 RNAV holding fixes should be defined using the XTT and ATT values for en-route, except where the hold is less than 56 km (30 NM) of the ARP, where STAR values should be used.

2.2.3.3 Results of calculations of the semi-width for the most common applications are shown as examples as follows (the semi-width for all applications can be calculated using the formulae in paragraphs 2.2.1 and 2.2.3):

- a) *RNP 4*: Tables III-1-2-1 and III-1-2-2;
- b) *RNP 2*: Tables III-1-2-3 and III-1-2-4;
- c) *RNP-1 (Aeroplane)*: Tables III-1-2-5 and III-1-2-6;
- d) *RNP-1 (CAT H)*: Tables III-1-2-7 and III-1-2-8;
- e) *Advanced RNP*: Tables III-1-2-9 and III-1-2-10 Optional ARNP semi-width and ATT values can be calculated using the formulae in paragraph 2.2.1 and 2.2.3;
- f) *RNP 0.3 (CAT H)*: Tables III-1-2-11 and III-1-2-12;
- g) *RNP (APCH) (Aeroplane)*: Tables III-1-2-13 and III-1-2-14;
- h) *RNP APCH (CAT H)*: Tables III-1-2-15 and III-1-2-16;
- i) *RNAV 1 and RNAV 2*: Tables III-1-2-17 and III-1-2-18;
- j) *RNAV 1 and RNAV 2 (CAT H)*: Tables III-1-2-19 and III-1-2-20;
- k) *RNAV 5*: Tables III-1-2-21 and III-1-2-22.

Table III-1-2-1. XTT, ATT and area semi-width for RNP 4 in the en-route phase of flight (km)

<i>En-route/STAR/SID (>56 km ARP)</i>		
<i>XTT</i>	<i>ATT</i>	<i>½ A/W</i>
7 408	5 926	14 820

Table III-1-2-2. XTT, ATT and area semi-width for RNP 4 in the en-route phase of flight (NM)

<i>En-route/STAR/SID (>30 NM ARP)</i>		
<i>XTT</i>	<i>ATT</i>	<i>½ A/W</i>
4.00	3.20	8.00

Table III-1-2-3. XTT, ATT, area semi-width for RNP 2 in en-route phase of flight (m)

<i>En-route/STAR/SID (>56 km ARP)</i>		
<i>XTT</i>	<i>ATT</i>	<i>½ A/W</i>
3 704	2 963	9 260

Table III-1-2-4. XTT, ATT, area semi-width for RNP 2 in en-route phase of flight (NM)

<i>En-route/STAR/SID (>30 NM ARP)</i>		
<i>XTT</i>	<i>ATT</i>	<i>½ A/W</i>
2.00	1.60	5.00

Table III-1-2-5. XTT, ATT and area semi-width for RNP-1 in arrival and departure phases of flight (m)

<i>STAR/SID</i> (<i>>56 km ARP</i>)			<i>STAR/SID</i> (<i><56 km ARP</i>)			<i>SID</i> (<i><28 km ARP</i>)		
<i>XTT</i>	<i>ATT</i>	<i>½ A/W</i>	<i>XTT</i>	<i>ATT</i>	<i>½ A/W</i>	<i>XTT</i>	<i>ATT</i>	<i>½ A/W</i>
1 852	1 482	6 482	1 852	1 482	4 630	1 852	1 482	3 704

Table III-1-2-6. XTT, ATT and area semi-width for RNP-1 (aeroplane) in arrival and departure phases of flight (NM)

<i>STAR/SID</i> (<i>>30 NM ARP</i>)			<i>STAR/SID</i> (<i><30 NM ARP</i>)			<i>SID</i> (<i><15 NM ARP</i>)		
<i>XTT</i>	<i>ATT</i>	<i>½ A/W</i>	<i>XTT</i>	<i>ATT</i>	<i>½ A/W</i>	<i>XTT</i>	<i>ATT</i>	<i>½ A/W</i>
1.00	0.80	3.50	1.00	0.80	2.50	1.00	0.80	2.00

Table III-1-2-7. XTT, ATT and area semi-width for RNP-1 (CAT H) in arrival and departure phases of flight (m)

<i>STAR/SID</i> (<i>>56 km ARP</i>)			<i>STAR/SID</i> (<i><56 km ARP</i>)			<i>SID</i> (<i><28 km ARP</i>)		
<i>XTT</i>	<i>ATT</i>	<i>½ A/W</i>	<i>XTT</i>	<i>ATT</i>	<i>½ A/W</i>	<i>XTT</i>	<i>ATT</i>	<i>½ A/W</i>
1 852	1 482	4 630	1 852	1 482	4 074	1 852	1 482	3 426

Table III-1-2-8. XTT, ATT and area semi-width for RNP 1 (CAT H) in arrival and departure phases of flight (NM)

<i>STAR/SID</i> (<i>>30 NM ARP</i>)			<i>STAR/SID</i> (<i><30 NM ARP</i>)			<i>SID</i> (<i><15 NM ARP</i>)		
<i>XTT</i>	<i>ATT</i>	<i>½ A/W</i>	<i>XTT</i>	<i>ATT</i>	<i>½ A/W</i>	<i>XTT</i>	<i>ATT</i>	<i>½ A/W</i>
1.00	0.80	2.50	1.00	0.80	2.20	1.00	0.80	1.85

Table III-1-2-9. XTT, ATT and area semi-width for Advanced RNP in all phases of flight (aeroplane) (m)

RNP	En-route (Continental & Remote)			STAR/SID (>56 km ARP)			STAR/SID/IF/IAF/ Missed Approach (<56 km ARP)			FAF			MAPt			Missed Approach/ SID (<28 km ARP)		
	XTT	ATT	½ A/W	XTT	ATT	½ A/W	XTT	ATT	½ A/W	XTT	ATT	½ A/W	XTT	ATT	½ A/W	XTT	ATT	½ A/W
2	3704	2964	9260	–	–	–	–	–	–	–	–	–	–	–	–	–	–	–
1	1852	1482	6482	1852	1482	6482	1852	1482	4630	–	–	–	–	–	–	1852	1482	3704
0.3	–	–	–	–	–	–	–	–	–	556	444	2685	556	444	1759	–	–	–

Table III-1-2-10. XTT, ATT and area semi-width for Advanced RNP in all phases of flight (Aeroplane) (NM)

RNP	En-route (Continental & Remote)			STAR/SID (>30 NM ARP)			STAR/SID (<30 NM ARP) IAF/IF/Missed Approach			FAF			MAPt			Missed Approach/ SID (<15 NM ARP)		
	XTT	ATT	½ A/W	XTT	ATT	½ A/W	XTT	ATT	½ A/W	XTT	ATT	½ A/W	XTT	ATT	½ A/W	XTT	ATT	½ A/W
2	2	1.6	5.0	–	–	–	–	–	–	–	–	–	–	–	–	–	–	–
1	1	0.8	3.5	1	0.8	3.5	1	0.8	2.5	–	–	–	–	–	–	1	0.8	2
0.3	–	–	–	–	–	–	–	–	–	0.3	0.24	1.45	0.3	0.24	0.95	–	–	–

Table III-1-2-11. XTT, ATT and area semi-width for RNP 0.3 (m) (CAT H)

En-route/STAR/SID (>56 km ARP)			STAR/SID/IF/IAF/Missed Approach (≤56 km ARP)			SID/Missed Approach (<28 km ARP)		
XTT	ATT	½ A/W	XTT	ATT	½ A/W	XTT	ATT	½ A/W
556	444	2 685	556	444	2 130	556	444	1 482

Table III-1-2-12. XTT, ATT and area semi-width for RNP 0.3 (NM) (CAT h)

En-route/STAR/SID (>30 NM ARP)			STAR/SID/IF/IAF/Missed Approach (≤30 NM ARP)			SID/Missed Approach (<15 NM ARP)		
XTT	ATT	½ A/W	XTT	ATT	½ A/W	XTT	ATT	½ A/W
0.30	0.24	1.45	0.30	0.24	1.15	0.30	0.24	0.80

Table III-1-2-13. XTT, ATT and area semi-width for RNP APCH (aeroplane) in initial/intermediate/final approach and missed approach phases of flight (m)

<i>IF/IAF/missed approach (<56 km ARP)</i>			<i>FAF</i>			<i>MAPt/Initial Straight Missed Approach (LP/LPV only)</i>			<i>Missed approach (<28 km ARP)</i>		
<i>XTT</i>	<i>ATT</i>	<i>½ A/W</i>	<i>XTT</i>	<i>ATT</i>	<i>½ A/W</i>	<i>XTT</i>	<i>ATT</i>	<i>½ A/W</i>	<i>XTT</i>	<i>ATT</i>	<i>½ A/W</i>
1 852	1 482	4 630	556	444	2 685	556	444	1 759	1 852	1 482	3 704

Table III-1-2-14. XTT and ATT, area semi-width for RNP APCH (aeroplane) in initial/intermediate/final approach and missed approach phases of flight (NM)

<i>IF/IAF/missed approach (<30 NM ARP)</i>			<i>FAF</i>			<i>MAPt/Initial Straight Missed Approach (LP/LPV only)</i>			<i>Missed approach (<15 NM ARP)</i>		
<i>XTT</i>	<i>ATT</i>	<i>½ A/W</i>	<i>XTT</i>	<i>ATT</i>	<i>½ A/W</i>	<i>XTT</i>	<i>ATT</i>	<i>½ A/W</i>	<i>XTT</i>	<i>ATT</i>	<i>½ A/W</i>
1.00	0.80	2.50	0.30	0.24	1.45	0.30	0.24	0.95	1.00	0.80	2.00

Table III-1-2-15. XTT, ATT and area semi-width for RNP APCH (CAT H) in initial/intermediate/final approach and missed approach phases of flight (m)

<i>IF/IAF/missed approach (<56 km ARP)</i>			<i>FAF</i>			<i>MAPt/Initial Straight Missed Approach (LP/LPV only)</i>			<i>Missed approach (<28 km ARP)</i>		
<i>XTT</i>	<i>ATT</i>	<i>½ A/W</i>	<i>XTT</i>	<i>ATT</i>	<i>½ A/W</i>	<i>XTT</i>	<i>ATT</i>	<i>½ A/W</i>	<i>XTT</i>	<i>ATT</i>	<i>½ A/W</i>
1 852	1 482	4 074	556	444	2 130	556	444	1 482	1 852	1 482	3 426

Table III-1-2-16. XTT, ATT and area semi-width for RNP APCH (CAT H) in en-route, arrival, initial/intermediate/final approach and missed approach phases of flight (NM)

<i>IF/IAF/missed approach (<30 NM ARP)</i>			<i>FAF</i>			<i>MAPt/Initial Straight Missed Approach (LP/LPV only)</i>			<i>Missed approach (<15 NM ARP)</i>		
<i>XTT</i>	<i>ATT</i>	<i>½ A/W</i>	<i>XTT</i>	<i>ATT</i>	<i>½ A/W</i>	<i>XTT</i>	<i>ATT</i>	<i>½ A/W</i>	<i>XTT</i>	<i>ATT</i>	<i>½ A/W</i>
1.00	0.80	2.20	0.30	0.24	1.15	0.30	0.24	0.80	1.00	0.80	1.85

Table III-1-2-17. XTT, ATT and area semi-width for RNAV 1 and RNAV 2 (Cat A to E) in en-route, arrival, initial/intermediate approach and departure phases of flight (m)

<i>En-route/STAR/SID</i> (>56 km ARP)			<i>STAR/IF/IAF/SID</i> (<56 km ARP)			<i>SID</i> (<28 km ARP)		
<i>XTT</i>	<i>ATT</i>	<i>½ A/W</i>	<i>XTT</i>	<i>ATT</i>	<i>½ A/W</i>	<i>XTT</i>	<i>ATT</i>	<i>½ A/W</i>
3 704	2 963	9 260	1 852	1 482	4 630	1 852	1 482	3 704

Table III-1-2-18. XTT, ATT and area semi-width for RNAV 1 and RNAV 2 (Cat A to E) in en-route, arrival, initial/intermediate approach and departure phases of flight (NM)

<i>En-route/STAR/SID</i> (>30 NM ARP)			<i>STAR/IF/IAF/SID</i> (<30 NM ARP)			<i>SID</i> (<15 NM ARP)		
<i>XTT</i>	<i>ATT</i>	<i>½ A/W</i>	<i>XTT</i>	<i>ATT</i>	<i>½ A/W</i>	<i>XTT</i>	<i>ATT</i>	<i>½ A/W</i>
2.00	1.60	5.00	1.00	0.80	2.50	1.00	0.80	2.00

Table III-1-2-19. XTT, ATT and area semi-width for RNAV 1 and RNAV 2 (Cat H) in en-route, arrival, initial/intermediate approach and departure phases of flight (m)

<i>En-route/STAR/SID</i> (>56 km ARP)			<i>STAR/IF/IAF/SID</i> (<56 km ARP)			<i>SID</i> (<28 km ARP)		
<i>XTT</i>	<i>ATT</i>	<i>½ A/W</i>	<i>XTT</i>	<i>ATT</i>	<i>½ A/W</i>	<i>XTT</i>	<i>ATT</i>	<i>½ A/W</i>
3 700	2 960	7 400	1 850	1 480	4 070	1 850	1 480	3 420

Table III-1-2-20. XTT, ATT and area semi-width for RNAV 1 and RNAV 2 (Cat H) in en-route, arrival, initial/intermediate approach and departure phases of flight (NM)

<i>En-route/STAR/SID</i> (>30 NM ARP)			<i>STAR/IF/IAF/SID</i> (<30 NM ARP)			<i>SID</i> (<15 NM ARP)		
<i>XTT</i>	<i>ATT</i>	<i>½ A/W</i>	<i>XTT</i>	<i>ATT</i>	<i>½ A/W</i>	<i>XTT</i>	<i>ATT</i>	<i>½ A/W</i>
2.00	1.60	4.00	1.00	0.80	2.20	1.00	0.80	1.85

Table III-1-2-21. XTT, ATT and area semi-width for RNAV 5 in the en-route phase of flight (m)

<i>En-route/STAR/SID</i> (>56 km ARP)		
<i>XTT</i>	<i>ATT</i>	<i>½ A/W</i>
4 650	3 720	10 690

Table III-1-2-22. XTT, ATT and area semi-width for RNAV 5 in the en-route phase of flight (NM)

<i>En-route/STAR/SID (>30 NM ARP)</i>		
<i>XTT</i>	<i>ATT</i>	<i>½ A/W</i>
2.51	2.01	5.77

Chapter 3

DME/DME RNAV

3.1 GENERAL

3.1.1 This chapter provides design criteria for DME/DME RNAV in RNAV 1 and RNAV 2 navigation applications, which are applicable to operations in the continental en-route and terminal phases of flight, including SIDs, STARs and initial approaches up to, but not including, final approach/missed approach. It also addresses RNAV 5 applications, which are applicable to operations in the continental en-route phase of flight only. The provisions of Part I, Section 2, Chapter 4, “Quality Assurance” as amplified or modified in this chapter apply.

3.1.2 The criteria in this chapter are not appropriate for RNP applications. Where DME/DME positioning is used to support RNP applications, the existing RNP 1 and RNP APCH criteria should be used, as appropriate.

3.2 AIRBORNE AND GROUND EQUIPMENT REQUIREMENTS FOR DME/DME PROCEDURES

3.2.1 The standard assumptions for airborne and ground equipment on which DME/DME procedures are based are as follows.

- a) DME station coordinates are referenced to WGS-84 and elevations in AMSL (where a DME is not exactly collocated with a VOR, the location and elevation of the DME should be published separately in the AIP).
- b) Airborne equipment complies with the guidance laid down in the ICAO *Performance-based Navigation (PBN) Manual* (Doc 9613):
 - 1) Volume II, Part B, Chapter 2, Implementing RNAV 5; or
 - 2) Volume II, Part B, Chapter 3, Implementing RNAV 1 and RNAV 2.
- c) Ground equipment complies with the criteria laid down in ICAO Annex 10 and does not contribute an error of more than 185 m/0.1 NM, 95 per cent of the time.

3.3 DME/DME RNAV SYSTEM USE ACCURACY

3.3.1 The system use accuracy (DTT) of airborne receiving systems is defined as:

$$2\sigma = 2 \frac{\sqrt{(\sigma_{1,air}^2 + \sigma_{1,sys}^2) + (\sigma_{2,air}^2 + \sigma_{2,sys}^2)}}{Sina}$$

where: $\sigma_{\text{sis}} = 0.05 \text{ NM}$,

$\sigma_{\text{air}} = \text{MAX}\{0.085 \text{ NM}, 0.125 \text{ per cent distance (as defined in RTCA DO-189 and TSO-C66c)}\}$ for RNAV 1 and RNAV 2

and

$$30 \leq \alpha \leq 150.$$

3.3.2 The ATT, XTT and $\frac{1}{2}$ A/W values are calculated for $\alpha = 90^\circ$ where more than 2 DME stations are usable throughout the procedure (i.e. at least 2 DME pairs available at any point on the track); otherwise a value of $\alpha = 30^\circ$ is used.

Note.— Theoretical maximum radio horizon in km is $4.11 \sqrt{h}$, where h is in metres. Theoretical maximum radio horizon in NM is $1.23 \sqrt{h}$, where h is in feet.

3.4 FLIGHT TECHNICAL TOLERANCE

The FTE values detailed in Table III-1-1-1 are applied.

3.5 SYSTEM COMPUTATIONAL TOLERANCE

The system computational tolerance (ST) is $\pm 463 \text{ m}$ (0.25 NM). This tolerance is dependent upon the implementation of WGS-84.

3.6 XTT, ATT AND AREA SEMI-WIDTH

3.6.1 XTT and ATT

3.6.1.1 The combination of the tolerances specified in 3.3 to 3.5 on a root sum square basis gives the cross-track and along-track tolerance of any fix defined by waypoints as follows:

$$XTT = \sqrt{DTT^2 + FTE^2 + ST^2}$$

$$ATT = \sqrt{DTT^2 + ST^2}$$

3.6.1.2 Results of calculations of XTT and ATT are shown as follows:

- a) RNAV 1: Tables III-1-3-1 to III-1-3-4;
- b) RNAV 2: Tables III-1-3-5 and III-1-3-6;
- c) RNAV 5: Tables III-1-3-7 and III-1-3-8.

3.6.2 Area semi-width

3.6.2.1 Area semi-width ($\frac{1}{2}$ A/W) at a waypoint is determined by the following equation:

$$\frac{1}{2} A/W = 1.5 * XTT + BV$$

where: BV = buffer value (for values see Table III-1-1-3).

3.6.2.2 RNAV holding fixes should be defined using the XTT and ATT values for en-route, except where the hold is less than 30 NM of the ARP, where the STAR values should be used.

3.6.2.3 Results of calculations of the semi-width are shown as follows:

- a) RNAV 1: Tables III-1-3-1 to III-1-3-4;
- b) RNAV 2: Tables III-1-3-5 and III-1-3-6;
- c) RNAV 5: Tables III-1-3-7 and III-1-3-8.

3.7 NAVIGATION AID COVERAGE

3.7.1 As it is not possible to know which DME facilities the airborne system will use for a position update, a theoretical viability check should be made of the route to ensure that there is appropriate DME coverage available at any point along the proposed route, based upon at least two selected facilities (the coverage of DME stations is given in Figure III-1-3-1). The initial check should be carried out using a qualified DME screening model and should consider:

- a) the promulgated maximum range of the DME facility, allowing a theoretical maximum radio horizon of the station of 300 km/160 NM;
- b) maximum and minimum intersection angle of the DME stations (between 30° and 150°);
- c) that DME facilities within 5.6 km (3 NM) of the design track cannot be used for navigation; and
- d) promulgated restrictions in designated operational coverage, if any.

Note.— Several States and organizations such as the FAA and EUROCONTROL utilize DME screening tools.

3.7.2 The theoretical viability check should determine the coverage and redundancy over the route. If, at any point on the procedure, the positioning can only be achieved using a specific DME pair, then those DMEs are considered to be critical to the procedure. Procedures with critical DMEs have no redundancy. Critical DMEs shall be noted on the procedure chart.

3.7.3 If a TACAN, not meeting the DME-ranging requirements of Annex 10, falls within the possible update range, this station shall not be published in the civil AIP in order to discourage storage in an electronic airborne navigation database.

3.7.4 A DME station may be located above the nominal flight path provided that the performance is confirmed to be acceptable by flight inspection and the operational acceptability is closely monitored during the initial months of operation (at least 3 months).

Note.— Airborne systems use all DME facilities within a maximum range and determine the most suitable facilities for position estimation.

3.7.5 Where continuous DME/DME coverage cannot be achieved, the design must take account of the limitation by the use of a dead reckoning segment. The protected area shall splay 15° either side of track, starting from the edge of the primary area at the point where coverage is not available. The track distance outside coverage shall not exceed 19 km (10 NM). (In the initial departure segments, where DME coverage is often inadequate and the design is strongly influenced by the ATM requirements, the use of heading legs and initial turns at altitude or even conventional (non-RNAV) navigation should be considered). The service provider should ensure that there are no adverse effects on positioning from VOR/DME stations while outside DME/DME coverage.

Note.— Multi-sensor solutions involving the use of VOR/DME and/or DME/DME/IRU may be developed for specific scenarios.

3.8 VALIDATION

3.8.1 Ground validation

An initial validation of the proposed procedure may be made using flight simulators and/or FMC simulation software tools to check the predicted flight path for continuity and repeatability of the route. Such validation should include the effect of minimum and maximum IAS, winds, type and mass of aircraft and type of FMC.

3.8.2 Flight inspection

3.8.2.1 The initial theoretical viability check should be subsequently confirmed by flight inspection. The flight inspection organization should be provided with full details of the pre-design checks, including details of any critical DMEs.

3.8.2.2 The pre-promulgation flight check should include an analysis of the update history (use of DME stations for update). If the RNAV system uses DME stations outside their promulgated radio range, an additional check on the effect of the use of those stations should be made.

Table III-1-3-1. XTT, ATT and area semi-width for DME RNAV (RNAV 1) in en-route, arrival, initial/intermediate approach and departure phases of flight (km)
Table based on availability of two DME update stations

Altitude (m)	En-route/STAR/SID (>56 km ARP)			STAR/IF/IAF (<56 km ARP)			SID (<28 km DER)			FAF		
	XTT	ATT	½ A/W	XTT	ATT	½ A/W	XTT	ATT	½ A/W	XTT	ATT	½ A/W
4 500	For all altitudes			2.29	2.09	5.29	2.29	2.09	4.36			
4 200	2.29	2.09	7.14	2.23	2.03	5.20	2.23	2.03	4.27			
3 900				2.17	1.97	5.11	2.17	1.97	4.18			
3 600				2.11	1.90	5.02	2.11	1.90	4.09			
3 300				2.05	1.83	4.93	2.05	1.83	4.00			
3 000				1.99	1.76	4.83	1.99	1.76	3.90	1.82	1.76	3.65
2 700				1.92	1.68	4.73	1.92	1.68	3.80	1.74	1.68	3.54
2 400				1.85	1.60	4.63	1.85	1.60	3.70	1.67	1.60	3.43
2 100				1.78	1.52	4.52	1.78	1.52	3.59	1.59	1.52	3.31
1 800				1.70	1.43	4.41	1.70	1.43	3.48	1.50	1.43	3.18
1 500				1.63	1.34	4.29	1.63	1.34	3.36	1.41	1.34	3.05
1 200				1.54	1.24	4.17	1.54	1.24	3.24	1.32	1.24	2.91
300–900				1.46	1.13	4.05	1.46	1.13	3.12	1.22	1.13	2.76

Table III-1-3-2. XTT, ATT and area semi-width for DME RNAV (RNAV 1) in en-route, arrival, initial/intermediate approach and departure phases of flight (NM)
Table based on availability of two DME update stations

Altitude (ft)	En-route/STAR/SID (>30 NM ARP)			STAR/IF/IAF (<30 NM ARP)			SID (<15 NM DER)			FAF		
	XTT	ATT	½ A/W	XTT	ATT	½ A/W	XTT	ATT	½ A/W	XTT	ATT	½ A/W
15 000	For all altitudes			1.24	1.13	2.85	1.24	1.13	2.35			
14 000	1.24	1.13	3.85	1.20	1.10	2.81	1.20	1.10	2.31			
13 000				1.17	1.06	2.76	1.17	1.06	2.26			
12 000				1.14	1.02	2.71	1.14	1.02	2.21			
11 000				1.11	0.99	2.66	1.11	0.99	2.16			
10 000				1.07	0.95	2.61	1.07	0.95	2.11	0.98	0.95	1.97
9 000				1.04	0.91	2.55	1.04	0.91	2.05	0.94	0.91	1.91
8 000				1.00	0.86	2.50	1.00	0.86	2.00	0.90	0.86	1.85
7 000				0.96	0.82	2.44	0.96	0.82	1.94	0.86	0.82	1.79
6 000				0.92	0.77	2.38	0.92	0.77	1.88	0.81	0.77	1.72
5 000				0.88	0.72	2.32	0.88	0.72	1.82	0.76	0.72	1.65
4 000				0.83	0.67	2.25	0.83	0.67	1.75	0.71	0.67	1.57
1 000–3 000				0.79	0.61	2.18	0.79	0.61	1.68	0.66	0.61	1.49

Table III-1-3-3. XTT, ATT and area semi-width for DME RNAV (RNAV 1) in en-route, arrival, initial/intermediate approach and departure phases of flight (km)
Table based on availability of more than two DME update stations

Altitude (m)	En-route/STAR/SID (>56 km ARP)			STAR/IF/IAF (<56 km ARP)			SID (<28 km DER)			FAF		
	XTT	ATT	½ A/W	XTT	ATT	½ A/W	XTT	ATT	½ A/W	XTT	ATT	½ A/W
4 500	For all altitudes			1.45	1.12	4.03	1.45	1.12	3.11			
4 200	1.45	1.12	5.88	1.43	1.09	4.00	1.43	1.09	3.07			
3 900				1.41	1.06	3.96	1.41	1.06	3.04			
3 600				1.39	1.03	3.93	1.39	1.03	3.00			
3 300				1.36	1.00	3.89	1.36	1.00	2.97			
3 000				1.34	0.97	3.86	1.34	0.97	2.93	1.07	0.97	2.53
2 700				1.31	0.93	3.82	1.31	0.93	2.90	1.04	0.93	2.49
2 400				1.29	0.90	3.78	1.29	0.90	2.86	1.01	0.90	2.44
2 100				1.26	0.86	3.75	1.26	0.86	2.82	0.98	0.86	2.39
1 800				1.24	0.82	3.71	1.24	0.82	2.78	0.94	0.82	2.34
1 500				1.21	0.78	3.67	1.21	0.78	2.74	0.91	0.78	2.29
1 200				1.18	0.74	3.63	1.18	0.74	2.70	0.87	0.74	2.23
300–900				1.16	0.69	3.59	1.16	0.69	2.66	0.83	0.69	2.18

Table III-1-3-4. XTT, ATT and area semi-width for DME RNAV (RNAV 1) in en-route, arrival, initial/intermediate approach and departure phases of flight (NM)
Table based on availability of more than two DME update stations

Altitude (ft)	En-route/STAR/SID (>30 NM ARP)			STAR/IF/IAF (<30 NM ARP)			SID (<15 NM DER)			FAF		
	XTT	ATT	½ A/W	XTT	ATT	½ A/W	XTT	ATT	½ A/W	XTT	ATT	½ A/W
15 000	For all altitudes			0.78	0.61	2.18	0.78	0.61	1.68			
14 000	0.78	0.61	3.18	0.77	0.59	2.16	0.77	0.59	1.66			
13 000				0.76	0.57	2.14	0.76	0.57	1.64			
12 000				0.75	0.56	2.12	0.75	0.56	1.62			
11 000				0.74	0.54	2.10	0.74	0.54	1.60			
10 000				0.72	0.52	2.08	0.72	0.52	1.58	0.58	0.52	1.37
9 000				0.71	0.50	2.06	0.71	0.50	1.56	0.56	0.50	1.34
8 000				0.70	0.48	2.04	0.70	0.48	1.54	0.54	0.48	1.32
7 000				0.68	0.46	2.02	0.68	0.46	1.52	0.53	0.46	1.29
6 000				0.67	0.44	2.00	0.67	0.44	1.50	0.51	0.44	1.26
5 000				0.65	0.42	1.98	0.65	0.42	1.48	0.49	0.42	1.23
4 000				0.64	0.40	1.96	0.64	0.40	1.46	0.47	0.40	1.20
1 000– 3 000				0.62	0.37	1.94	0.62	0.37	1.44	0.45	0.37	1.18

Table III-1-3-5. XTT, ATT and area semi-width for DME RNAV (RNAV 2) in en-route, arrival, initial/intermediate approach and departure phases of flight (km)
Table based on availability of two DME update stations

Altitude (m)	En-route/STAR/SID (>56 km ARP)			STAR/IF/IAF (<56 km ARP)			SID (<28 km DER)			FAF		
	XTT	ATT	½ A/W	XTT	ATT	½ A/W	XTT	ATT	½ A/W	XTT	ATT	½ A/W
4 500	For all altitudes			2.79	2.09	6.04	2.79	2.09	5.12			
4 200	2.79	2.09	7.90	2.75	2.03	5.97	2.75	2.03	5.05			
3 900				2.70	1.97	5.90	2.70	1.97	4.98			
3 600				2.65	1.90	5.83	2.65	1.90	4.90			
3 300				2.60	1.83	5.76	2.60	1.83	4.83			
3 000				2.55	1.76	5.68	2.55	1.76	4.75	N/A	N/A	N/A
2 700				2.50	1.68	5.60	2.50	1.68	4.68	N/A	N/A	N/A
2 400				2.45	1.60	5.52	2.45	1.60	4.60	N/A	N/A	N/A
2 100				2.39	1.52	5.44	2.39	1.52	4.52	N/A	N/A	N/A
1 800				2.34	1.43	5.36	2.34	1.43	4.44	N/A	N/A	N/A
1 500				2.28	1.34	5.28	2.28	1.34	4.35	N/A	N/A	N/A
1 200				2.23	1.24	5.19	2.23	1.24	4.27	N/A	N/A	N/A
300–900				2.17	1.13	5.11	2.17	1.13	4.18	N/A	N/A	N/A

Table III-1-3-6. XTT, ATT, area semi-width for DME RNAV (RNAV 2) in en-route, arrival, initial/intermediate approach and departure phases of flight (NM)
Table based on availability of two DME update stations

Altitude (ft)	En-route/STAR/SID (>30 NM ARP)			STAR/IF/IAF (<30 NM ARP)			SID (<15 NM DER)			FAF		
	XTT	ATT	½ A/W	XTT	ATT	½ A/W	XTT	ATT	½ A/W	XTT	ATT	½ A/W
15 000	For all altitudes			1.51	1.13	3.26	1.51	1.13	2.76			
14 000	1.51	1.13	4.26	1.48	1.10	3.23	1.48	1.10	2.73			
13 000				1.46	1.06	3.19	1.46	1.06	2.69			
12 000				1.43	1.02	3.15	1.43	1.02	2.65			
11 000				1.41	0.99	3.11	1.41	0.99	2.61			
10 000				1.38	0.95	3.07	1.38	0.95	2.57	N/A	N/A	N/A
9 000				1.35	0.91	3.03	1.35	0.91	2.53	N/A	N/A	N/A
8 000				1.32	0.86	2.98	1.32	0.86	2.48	N/A	N/A	N/A
7 000				1.29	0.82	2.94	1.29	0.82	2.44	N/A	N/A	N/A
6 000				1.26	0.77	2.90	1.26	0.77	2.40	N/A	N/A	N/A
5 000				1.23	0.72	2.85	1.23	0.72	2.35	N/A	N/A	N/A
4 000				1.20	0.67	2.80	1.20	0.67	2.30	N/A	N/A	N/A
1 000–3 000				1.17	0.61	2.76	1.17	0.61	2.26	N/A	N/A	N/A

**Table III-1-3-7. XTT, ATT, area semi-width for DME RNAV (RNAV 5)
in the en-route phase of flight (km)
Table based on availability of two DME update stations**

<i>En-route/STAR/SID (>56 km ARP)</i>		
<i>XTT</i>	<i>ATT</i>	<i>½ A/W</i>
For all altitudes		
6.11	3.98	12.86

**Table III-1-3-8. XTT, ATT, area semi-width for DME RNAV (RNAV 5)
in the en-route phase of flight (NM)
Table based on availability of two DME update stations**

<i>En-route/STAR/SID (>30 NM ARP)</i>		
<i>XTT</i>	<i>ATT</i>	<i>½ A/W</i>
For all altitudes		
3.30	2.15	6.95

Note.— The altitude applied for the calculation in all the tables above is assumed to be the minimum altitude (rounded up to the next higher value) of the previous segment of the procedure in the case of an arrival/approach phase of flight. In the case of a turn altitude for a departure/missed approach procedure, a climb gradient of 3.3 per cent, or equal to the lowest specified climb gradient if greater than 3.3 per cent, is assumed. For specific cases, e.g. high-altitude airports, the assumed height of the aircraft is applied instead of the altitude. In that case, the height must be related to the lowest DME station located within the maximum range of DME reception.

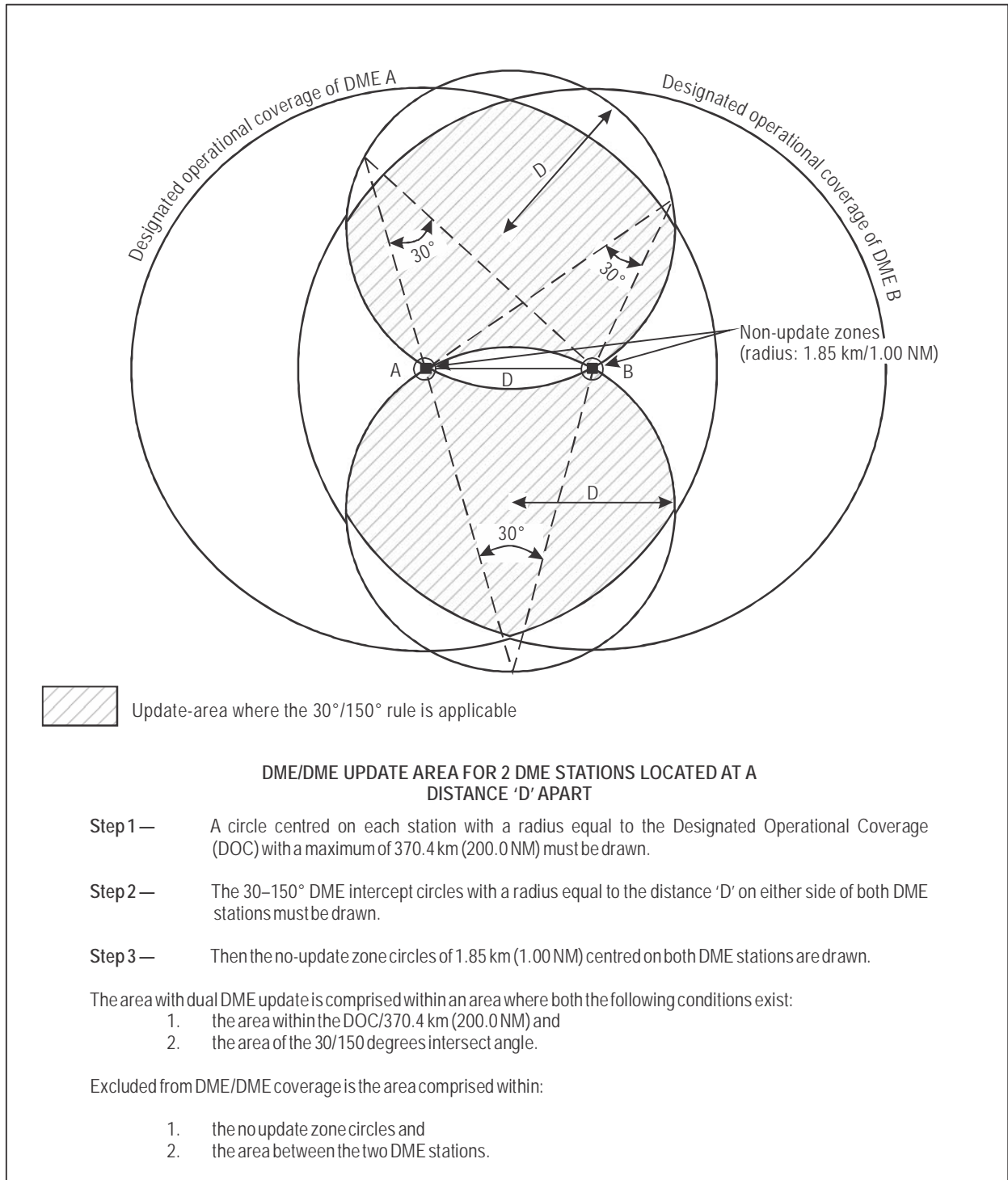

Figure III-1-3-1. Maximum update area of two DME stations A and B

Chapter 4

VOR/DME RNAV

4.1 GENERAL

This chapter provides design criteria for VOR/DME RNAV in RNAV 5 navigation applications, which are applicable to operations in the continental en-route phase of flight only. The criteria are not appropriate for VOR/DME approaches.

4.1.1 Reference facilities

Although it is not possible to know which VOR/DME facility the airborne system will use for a position update, a check should be made to ensure that there is appropriate coverage available from at least one reference facility within a 60 NM range, or 75 NM for Doppler VOR. The designer should select the VOR/DME facility that provides the optimum geometry for the track guidance solution at each waypoint, to calculate the XTT, ATT and $\frac{1}{2}$ A/W at those waypoints.

4.2 AIRBORNE AND GROUND EQUIPMENT REQUIREMENTS FOR VOR/DME PROCEDURES

The standard assumptions for airborne and ground equipment on which VOR/DME procedures are based are as follows:

- a) VOR/DME station coordinates are published in WGS-84 and elevations in AMSL. (Where a DME is not exactly collocated with a VOR, the location and elevation of the DME should be published separately in the AIP.)
- b) Airborne equipment complies with the criteria laid down in the ICAO *Performance-based Navigation (PBN) Manual* (Doc 9613), Volume II, Part B, Chapter 2, "Implementing RNAV 5".
- c) Ground equipment complies with the criteria laid down in ICAO Annex 10.

4.3 VOR/DME RNAV SYSTEM USE ACCURACY

4.3.1 Accuracy

The operational performances of the area navigation equipment shall be such that the tolerances which determine the system use accuracy remain within the values specified in 4.3.2 through 4.4. These values are based on 2 sigma (95 per cent) confidence limits.

4.3.2 Navigation accuracy factors

The factors on which the navigation accuracy of VOR/DME RNAV depends are:

- a) ground station tolerance;
- b) airborne receiving system tolerance;
- c) flight technical tolerance;
- d) system computation tolerance; and
- e) distance from the reference facility.

4.3.3 System use accuracies

4.3.3.1 The system use accuracy of the VOR is equal to the VOR system use accuracy of a facility not providing track, which is ± 4.5 degrees.

4.3.3.2 The system use accuracy of the DME is equal to the DME system use accuracy (DTT) of a facility not providing track guidance, which is $2\sigma = 2\sqrt{(\sigma_{1,air}^2 + \sigma_{1,sys}^2)}$ (see Annex 10, Volume I, 3.5.3.1.3.2)

where: $\sigma_{sys} = 0.05$ NM,

$\sigma_{air} = \text{MAX}\{0.085 \text{ NM}, 0.125 \text{ per cent distance (as defined in RTCA DO-189 and TSO-C66c)}\}$.

Note.— For further information on system use accuracies see Part I, Section 2, Chapter 2, “Terminal area fixes”.

4.4 FLIGHT TECHNICAL TOLERANCE

The standard PANS-OPS FTE values detailed in Table III-1-1-2 are applied.

4.5 SYSTEM COMPUTATION TOLERANCE

The system computation tolerance (ST) is assumed to be 463 m (0.25 NM).

4.6 XTT, ATT AND AREA SEMI-WIDTH

4.6.1 XTT and ATT

The combination of the tolerances specified in 4.3.2 to 4.5 on a root sum square basis gives the cross-track tolerance (XTT) and the along-track tolerance (ATT) of any fix as follows (see Figures III-1-4-1 and III-1-4-2):

$$XTT = \sqrt{VT^2 + DT^2 + FTT^2 + ST^2}$$

$$ATT = \sqrt{AVT^2 + ADT^2 + ST^2}$$

where: D is the distance from the reference facility to the waypoint; $D = [D1^2 + D2^2]^{1/2}$.

$D1$ is the tangent point distance. The tangent point is the perpendicular projection of the reference facility onto the nominal track. The tangent point distance ($D1$) is the distance from the reference facility to the tangent point.

$D2$ is the distance to the tangent point. This is the distance from the waypoint to the tangent point (see Figure III-1-4-1).

α = VOR system use accuracy (degrees)

DTT = DME system use accuracy

θ = $\arctan(D2/D1)$ (degrees) (if $D1 = 0$, $\theta = 90^\circ$)

VT = $D1 - D \cos(\theta + \alpha)$

DT = $DTT \cos \theta$

AVT = $D2 - D \sin(\theta - \alpha)$

ADT = $DTT \sin \theta$

Note.— ATT does not contain an FTT component.

4.6.2 Area semi-width

Area semi-width ($1/2 A/W$) at a waypoint is determined by

$$1.5 \times XTT + BV$$

where: 1.5 XTT corresponds to 3 sigma and

BV = buffer value (for values see Table III-1-1-3).

Results of calculations of the XTT, ATT and semi-width are shown in Table III-1-4-1 and Table III-1-4-2.

4.6.3 ATT and XTT track dependency

ATT and XTT are track dependent. Thus when a turn is specified at a fix, the ATT and XTT are different before and after the turn due to the individual fix geometry.

**Table III-1-4-1. XTT, ATT, area semi-width for VOR/DME RNAV
in the en-route phase of flight (RNAV 5) (km)**

<i>D1</i>	<i>D2</i>	<i>0</i>	<i>10</i>	<i>20</i>	<i>30</i>	<i>40</i>	<i>50</i>	<i>60</i>	<i>70</i>	<i>80</i>
<i>0</i>	XTT	4.7	4.8	5.3	6.1	7.0	8.0	9.0	10.2	11.3
	ATT	0.5	1.4	2.6	3.9	5.2	6.5	7.8	9.1	10.3
	½ A/W	10.7	9.1	8.9	9.1	10.4	11.9	17.3	17.1	17.6
<i>10</i>	XTT	4.7	4.9	5.5	6.4	7.5	8.7	9.9	11.2	12.6
	ATT	0.5	1.6	3.0	4.4	5.9	7.3	8.8	10.2	11.7
	½ A/W	10.7	11.0	12.0	13.3	14.9	16.7	18.6	20.6	22.6
<i>20</i>	XTT	4.7	4.9	5.5	6.5	7.5	8.7	10.0	11.3	12.6
	ATT	0.5	1.6	3.1	4.5	5.9	7.4	8.8	10.3	11.7
	½ A/W	10.7	11.1	12.0	13.4	15.0	16.8	18.7	20.6	22.6
<i>30</i>	XTT	4.7	4.9	5.6	6.5	7.6	8.8	10.0	11.3	12.7
	ATT	0.5	1.7	3.1	4.6	6.0	7.5	8.9	10.4	11.8
	½ A/W	10.7	11.1	12.1	13.4	15.1	16.9	18.8	20.7	22.7
<i>40</i>	XTT	4.7	5.0	5.6	6.5	7.6	8.8	10.1	11.4	12.7
	ATT	0.5	1.8	3.2	4.6	6.1	7.5	9.0	10.4	11.9
	½ A/W	10.7	11.1	12.1	13.5	15.1	16.9	18.8	20.8	22.8
<i>50</i>	XTT	4.7	5.0	5.6	6.6	7.7	8.9	10.1	11.4	12.8
	ATT	0.6	1.8	3.2	4.7	6.1	7.6	9.0	10.5	11.9
	½ A/W	10.7	11.2	12.2	13.6	15.2	17.0	18.9	20.9	22.9
<i>60</i>	XTT	4.7	5.0	5.7	6.6	7.7	8.9	10.2	11.5	12.8
	ATT	0.6	1.9	3.3	4.7	6.2	7.6	9.1	10.5	12.0
	½ A/W	10.7	11.2	12.2	13.6	15.3	17.1	19.0	21.0	23.0
<i>70</i>	XTT	4.7	5.0	5.7	6.7	7.8	9.0	10.2	11.6	12.9
	ATT	0.6	1.9	3.3	4.8	6.2	7.7	9.1	10.6	12.0
	½ A/W	10.7	11.2	12.3	13.7	15.3	17.2	19.1	21.0	23.0
<i>80</i>	XTT	4.7	5.0	5.7	6.7	7.8	9.0	10.3	11.6	12.9
	ATT	0.7	2.0	3.4	4.8	6.3	7.7	9.2	10.6	12.1
	½ A/W	10.7	11.3	12.3	13.8	15.4	17.2	19.1	21.1	23.1

**Table III-1-4-2. XTT, ATT, area semi-width for VOR/DME RNAV
in the en-route phase of flight (RNAV 5) (NM)**

<i>D1</i>	<i>D2</i>	0	10	20	30	40	50	60	70	80
0	XTT	2.5	2.6	2.9	3.3	3.8	4.3	4.9	5.5	6.1
	ATT	0.3	0.7	1.4	2.1	2.8	3.5	4.2	4.9	5.6
	½ A/W	5.8	4.9	4.8	4.9	5.6	6.4	9.3	9.2	9.5
10	XTT	2.5	2.6	3.0	3.5	4.0	4.7	5.4	6.1	6.8
	ATT	0.3	0.9	1.6	2.4	3.2	4.0	4.7	5.5	6.3
	½ A/W	5.8	6.0	6.5	7.2	8.1	9.0	10.0	11.1	12.2
20	XTT	2.5	2.7	3.0	3.5	4.1	4.7	5.4	6.1	6.8
	ATT	0.3	0.9	1.7	2.4	3.2	4.0	4.8	5.6	6.3
	½ A/W	5.8	6.0	6.5	7.2	8.1	9.1	10.1	11.1	12.2
30	XTT	2.5	2.7	3.0	3.5	4.1	4.7	5.4	6.1	6.8
	ATT	0.3	0.9	1.7	2.5	3.2	4.0	4.8	5.6	6.4
	½ A/W	5.8	6.0	6.5	7.3	8.1	9.1	10.1	11.2	12.3
40	XTT	2.5	2.7	3.0	3.5	4.1	4.8	5.4	6.2	6.9
	ATT	0.3	0.9	1.7	2.5	3.3	4.1	4.8	5.6	6.4
	½ A/W	5.8	6.0	6.5	7.3	8.2	9.1	10.2	11.2	12.3
50	XTT	2.5	2.7	3.0	3.6	4.1	4.8	5.5	6.2	6.9
	ATT	0.3	1.0	1.7	2.5	3.3	4.1	4.9	5.7	6.4
	½ A/W	5.8	6.0	6.6	7.3	8.2	9.2	10.2	11.3	12.4
60	XTT	2.5	2.7	3.1	3.6	4.2	4.8	5.5	6.2	6.9
	ATT	0.3	1.0	1.8	2.6	3.3	4.1	4.9	5.7	6.5
	½ A/W	5.8	6.0	6.6	7.4	8.3	9.2	10.3	11.3	12.4
70	XTT	2.5	2.7	3.1	3.6	4.2	4.8	5.5	6.2	7.0
	ATT	0.3	1.0	1.8	2.6	3.4	4.1	4.9	5.7	6.5
	½ A/W	5.8	6.1	6.6	7.4	8.3	9.3	10.3	11.4	12.4
80	XTT	2.5	2.7	3.1	3.6	4.2	4.9	5.6	6.3	7.0
	ATT	0.4	1.1	1.8	2.6	3.4	4.2	5.0	5.7	6.5
	½ A/W	5.8	6.1	6.7	7.4	8.3	9.3	10.3	11.4	12.5

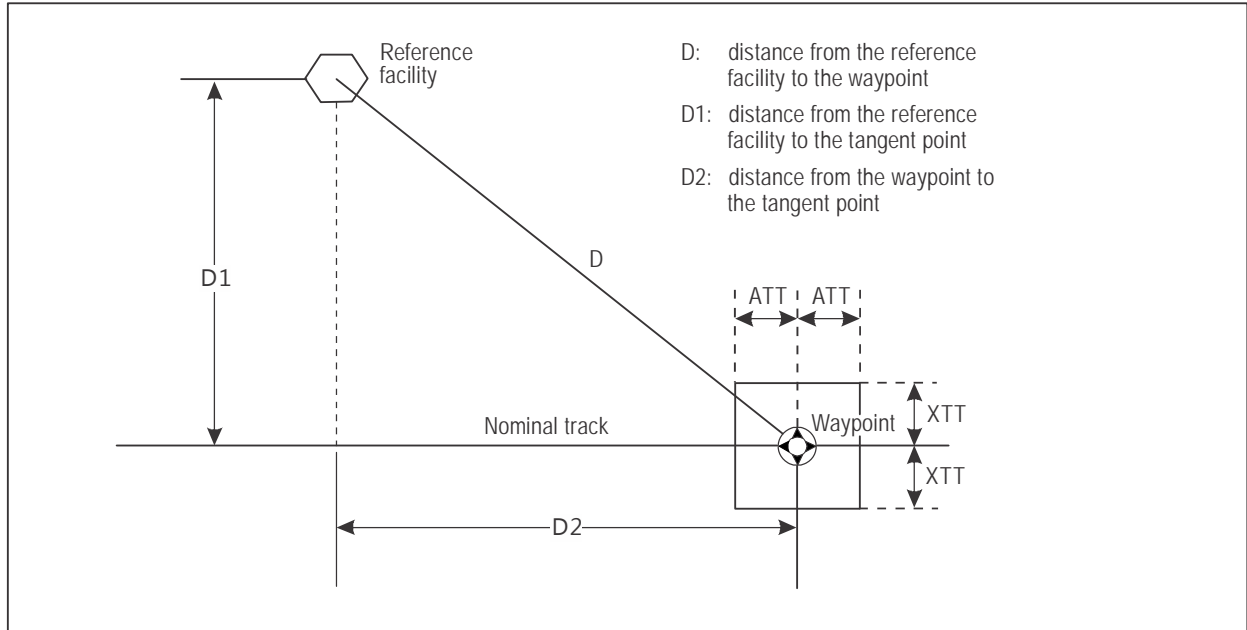

Figure III-1-4-1. Identification of waypoints

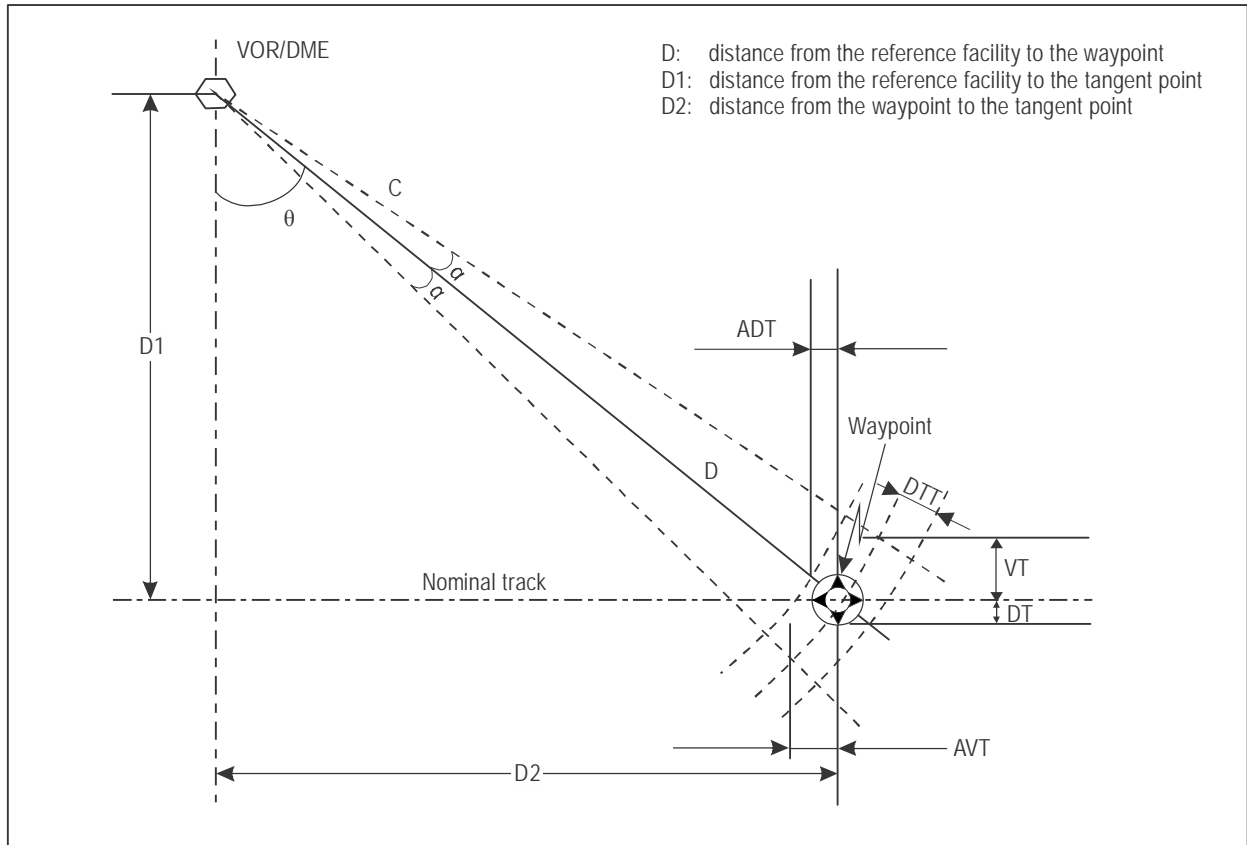

Figure III-1-4-2. Calculation of waypoint tolerances

Chapter 5

GBAS RNAV

(To be developed)

Section 2
GENERAL CRITERIA

Chapter 1

MINIMUM LENGTH OF A SEGMENT LIMITED BY TWO WAYPOINTS

1.1 GENERAL

1.1.1 To prevent waypoints being placed so close that RNAV systems are forced to bypass them, a minimum distance between successive waypoints must be taken into account. Two types of waypoints are considered:

- a) fly-by waypoint; and
- b) flyover waypoint.

1.1.2 Four sequences are possible for a segment limited by two waypoints:

- a) two fly-by waypoints;
- b) fly-by waypoint, then flyover waypoint;
- c) two flyover waypoints; and
- d) flyover waypoint, then fly-by waypoint.

In addition, the particular case of the segment “DER — first waypoint” must also be considered.

1.1.3 The following method is based on theoretical studies combined with the results of simulations. Some differences may exist between RNAV systems; algorithms used by these systems are complex. For these reasons, simplifications were made when establishing theoretical formulae.

1.1.4 The aim of the method is not to determine a protection area, but to determine a minimum distance between two waypoints on a nominal trajectory. For this reason, wind effect and waypoint tolerances are not taken into account in the theoretical calculations. When it is necessary, greater values may be chosen.

1.2 DETERMINATION OF THE MINIMUM LENGTH OF THE RNAV SEGMENT

1.2.1 General

For each waypoint a minimum stabilization distance is determined. This is the distance between the waypoint and the point where the trajectory joins tangentially with the nominal track (Figure III-2-1-1). For successive waypoints, the minimum distance between them is the sum of both minimum stabilization distances. The tables in this chapter show minimum stabilization distances for various values of true airspeed and course change (at the waypoint).

1.2.2 Minimum stabilization distance tables

Tables III-2-1-1 through III-2-1-20 show minimum stabilization distance. These tables are organized according to the following three parameters:

- a) units (SI or non-SI);
- b) type of waypoint (fly-by or flyover); and
- c) value of bank angle (15°, 20°, 25°).

Use the table below to locate the table which applies.

Organization of minimum stabilization distance tables

<i>Units</i>	<i>Type of waypoint</i>	<i>Bank angle</i>	<i>Table number</i>
Aeroplane			
(SI)	Fly-by	15°	III-2-1-1
		20°	III-2-1-2
		25°	III-2-1-3
	Flyover	15°	III-2-1-4
		20°	III-2-1-5
		25°	III-2-1-6
(Non-SI)	Fly-by	15°	III-2-1-7
		20°	III-2-1-8
		25°	III-2-1-9
	Flyover	15°	III-2-1-10
		20°	III-2-1-11
		25°	III-2-1-12
Helicopter			
(SI)	Fly-by	15°	III-2-1-13
		20°	III-2-1-14
	Flyover	15°	III-2-1-15
		20°	III-2-1-16
(Non-SI)	Fly-by	15°	III-2-1-17
		20°	III-2-1-18
	Flyover	15°	III-2-1-19
		20°	III-2-1-20

1.2.3 Determination of indicated and true airspeeds

1.2.3.1 *Airspeeds for approach procedures.* Use speeds shown in Table I-4-1-1 or I-4-1-2 of Part I, Section 4, Chapter 1. If a speed limitation is needed, use the limited speed. Convert the indicated airspeed into true airspeed, taking into account the altitude for which the procedure is protected.

1.2.3.2 *Airspeeds for departure procedures.* Use speeds defined in Part I, Section 3, Chapter 3. If a speed limitation is needed, use Table I-3-3-App-1 in Part I, Section 3, Appendix to Chapter 3 to check if this speed limitation is not lower than operationally acceptable. Convert the indicated airspeed into true airspeed, taking into account an altitude resulting from a 7 per cent climb gradient originating from the DER.

1.2.4 Choice of bank angle

1.2.4.1 For approach phases, the bank angle is 25°/(or 3°/s), except in the missed approach phase where a 15° bank angle is assumed. See the criteria in Part I, Section 4.

1.2.4.2 For departure phases, according to the choice of criteria made in 1.2.3.2, “Airspeeds for departure procedures”, the bank angle will be:

- a) 15° if Part II, Section 3, Chapter 3 criteria are used; and
- b) 15°, 20°, 25° according to the along track distance from the DER if the criteria in Part I, Section 3, Appendix to Chapter 3 are used.

1.2.5 Examples

1.2.5.1 *Two fly-by waypoints* (Figure III-2-1-2). For the first waypoint (WP1), find the minimum stabilization distance (A1), in the table, according to the bank angle and the true airspeed. For the second waypoint (WP2), find the minimum stabilization distance (A2) in the table, according to the bank angle and the true airspeed. The minimum distance between WP1 and WP2 = A1 + A2.

1.2.5.2 *Fly-by, then flyover waypoint* (Figure III-2-1-3). For the first waypoint (WP1), find the minimum stabilization distance (A1) according to the bank angle and the true airspeed. As the second waypoint (WP2) is a flyover way-point, the minimum distance between WP1 and WP2 is equal to A1 + 0 = A1.

1.2.5.3 *Two flyover waypoints* (Figure III-2-1-4). For the first waypoint (WP1), find the minimum stabilization distance (B1), according to the bank angle and the true airspeed. As the second waypoint is a flyover waypoint, the minimum distance between WP1 and WP2 is equal to B1 + 0 = B1.

1.2.5.4 *Flyover, then fly-by waypoint* (Figure III-2-1-5). For the first waypoint (WP1), find the minimum stabilization distance (B1), according to the bank angle and the true airspeed. For the second waypoint (WP2), find the minimum stabilization distance (A2), according to the bank angle and the true airspeed. The minimum distance between WP1 and WP2 is equal to B1 + A2.

1.3 PARTICULAR CASE OF THE SEGMENT: DER — FIRST WAYPOINT

The location of the first waypoint must provide a minimum distance of 3.5 km (1.9 NM) between the DER and the earliest turning point (K-line of Section 3, Chapter 1, Figure III-3-1-2). A shorter distance can be used when the PDG is higher than 3.3 per cent (see Part I, Section 3, Chapter 4, 4.1) (Figure III-2-1-6).

1.4 MINIMUM STABILIZATION DISTANCE

(Tables III-2-1-1 to III-2-1-20)

1.4.1 Flyover waypoint

1.4.1.1 *Components of the flyover turn.* A flyover turn is broken down into the following components for the purpose of calculating the minimum stabilization distance:

- a) an initial roll-in at the flyover point; followed by
- b) a straight 30° intercept course with the next leg;
- c) a roll-out at the new course; and
- d) a 10-second delay to account for bank establishing time.

1.4.1.2 *Model of the flyover turn.* In order to model the flyover turn procedure, its length is divided into five segments, L1 through L5 (see Figure III-2-1-7). The total length of the procedure is the sum of the five segments.

$$L1 = r1 \times \sin \theta$$

$$L2 = r1 \times \cos \theta \times \tan \alpha$$

$$L3 = r1 (1/\sin \alpha - 2 \cos \theta / \sin (90^\circ - \alpha))$$

$$L4 = r2 \tan (\alpha / 2)$$

$$L5 = c \times V/3600$$

$$L5 = 5V/3600 \text{ (for Cat H)}$$

where: α = 30 degree intercept course with the next leg;
 θ = turn angle;
 c = 10 second bank establishment time;
 $r1$ = roll-in radius; and
 $r2$ = roll-out radius.

In the above equations,

if distances and turn radii are in NM, V is in kt;
 if distances and turn radii are in km, V is in km/h.

1.4.1.3 *Bank angle of flyover turn.* For course changes of 50° or more (30° for category H aircraft), the minimum stabilization distance is determined assuming a bank angle equal to 15°, 20° or 25° according to the phases of flight for the first turn ($r1$) and equal to 15° for the second turn ($r2$). For course changes less than 50° (30° for category H aircraft), the minimum stabilization distance is equal to the value calculated for a course change of 50° (30° for category H aircraft).

1.4.2 Fly-by waypoint

1.4.2.1 *Model of the fly-by turn.* The model for calculating minimum stabilization distance for the fly-by waypoint is designed in a fashion similar to the flyover waypoint, as shown in Figure III-2-1-8. The model consists of a level turn with a constant radius r . The total length of the segment is the sum of L1 and L2, where:

L1 is the distance between the waypoint and the start of the turn.

L2 is a five-second delay to take into account the bank establishing time. The delay time is less than in the case of the flyover waypoint because the number of course changes is less.

$$L1 = r \times \tan (\theta / 2)$$

$$L2 = c \times V/3600$$

$$L2 = 3V/3600 \text{ (for Cat H)}$$

Where: c = 5 second bank establishment time;
 r = turn radius; and
 θ = turn angle.

In the above equations,

if distances and turn radii are in NM, V is in kt; or
 if distances and turn radii are in km, V is in km/h.

1.4.2.2 *Bank angle of fly-by turn.* For course changes of 50° or more (30° for category H aircraft) the minimum stabilization distance is determined assuming a bank angle equal to 15°, 20° or 25°, according to the phase of flight. For course changes less than 50° (30° for category H aircraft), the minimum stabilization distance is equal to the value calculated for a course change of 50° (30° for a category H aircraft).

1.5 DETERMINATION OF THE MINIMUM LENGTH OF AN RNAV SEGMENT LIMITED BY AT LEAST ONE WAYPOINT THAT IS NOT A TURNING WAYPOINT

To allow implementation of specific constraints, some waypoints that are not turning waypoints can be added within a straight segment. As for turning waypoints, these waypoints shall be located at a distance not lower than the minimum distance D from a waypoint, as defined in Table III-2-1-21.

Table III-2-1-1. Minimum stabilization distance between fly-by waypoints (SI units, 15° bank angle)

Course change* (Degrees)	True airspeed (km/h)														
	< or = 240	260	280	300	320	340	360	380	400	440	480	520	560	600	640
50	1.1	1.3	1.5	1.6	1.8	2.1	2.3	2.5	2.7	3.3	3.8	4.4	5.1	5.8	6.5
55	1.2	1.4	1.6	1.8	2.0	2.2	2.5	2.7	3.0	3.6	4.2	4.9	5.6	6.3	7.2
60	1.3	1.5	1.7	1.9	2.2	2.4	2.7	3.0	3.3	3.9	4.6	5.3	6.1	6.9	7.8
65	1.4	1.6	1.9	2.1	2.4	2.6	2.9	3.2	3.5	4.2	5.0	5.8	6.6	7.6	8.6
70	1.5	1.8	2.0	2.3	2.5	2.8	3.2	3.5	3.8	4.6	5.4	6.3	7.2	8.2	9.3
75	1.6	1.9	2.2	2.4	2.8	3.1	3.4	3.8	4.2	5.0	5.9	6.8	7.8	8.9	10.1
80	1.8	2.0	2.3	2.6	3.0	3.3	3.7	4.1	4.5	5.4	6.3	7.4	8.5	9.7	11.0
85	1.9	2.2	2.5	2.8	3.2	3.6	4.0	4.4	4.9	5.8	6.9	8.0	9.2	10.5	11.9
90	2.0	2.3	2.7	3.1	3.5	3.9	4.3	4.8	5.3	6.3	7.4	8.7	10.0	11.4	12.9
95	2.2	2.5	2.9	3.3	3.7	4.2	4.7	5.2	5.7	6.8	8.1	9.4	10.8	12.4	14.0
100	2.3	2.7	3.1	3.6	4.0	4.5	5.0	5.6	6.2	7.4	8.7	10.2	11.8	13.4	15.2
105	2.5	2.9	3.4	3.9	4.4	4.9	5.5	6.1	6.7	8.0	9.5	11.1	12.8	14.6	16.6
110	2.7	3.2	3.7	4.2	4.7	5.3	5.9	6.6	7.3	8.7	10.3	12.1	13.9	15.9	18.1
115	3.0	3.5	4.0	4.6	5.2	5.8	6.5	7.2	7.9	9.5	11.3	13.2	15.2	17.4	19.8
120	3.3	3.8	4.4	5.0	5.7	6.4	7.1	7.9	8.7	10.5	12.4	14.5	16.7	19.1	21.7

* Use the value of 50° for course changes lower than 50°.

**Table III-2-1-2. Minimum stabilization distance between fly-by waypoints
(SI units, 20° bank angle*)**

Course change** (Degrees)	True airspeed (km/h)														
	< or = 240	260	280	300	320	340	360	380	400	440	480	520	560	600	640
50	0.9	1.0	1.2	1.3	1.5	1.6	1.8	2.0	2.2	2.6	3.0	3.4	3.9	4.5	5.0
55	1.0	1.1	1.3	1.4	1.6	1.8	2.0	2.2	2.4	2.8	3.3	3.8	4.3	4.9	5.5
60	1.1	1.2	1.4	1.5	1.7	1.9	2.1	2.3	2.6	3.0	3.5	4.1	4.7	5.3	6.0
65	1.1	1.3	1.5	1.7	1.9	2.1	2.3	2.5	2.8	3.3	3.8	4.4	5.1	5.8	6.5
70	1.2	1.4	1.6	1.8	2.0	2.2	2.5	2.7	3.0	3.5	4.2	4.8	5.5	6.3	7.1
75	1.3	1.5	1.7	1.9	2.1	2.4	2.6	2.9	3.2	3.8	4.5	5.2	6.0	6.8	7.7
80	1.4	1.6	1.8	2.0	2.3	2.6	2.9	3.1	3.5	4.1	4.8	5.6	6.5	7.4	8.3
85	1.5	1.7	1.9	2.2	2.5	2.8	3.1	3.4	3.7	4.4	5.2	6.1	7.0	8.0	9.0
90	1.6	1.8	2.1	2.4	2.7	3.0	3.3	3.6	4.0	4.8	5.6	6.6	7.6	8.6	9.7
95	1.7	2.0	2.2	2.5	2.9	3.2	3.6	3.9	4.3	5.2	6.1	7.1	8.2	9.3	10.6
100	1.9	2.1	2.4	2.7	3.1	3.5	3.8	4.2	4.7	5.6	6.6	7.7	8.9	10.1	11.4
105	2.0	2.3	2.6	3.0	3.3	3.7	4.2	4.6	5.1	6.1	7.2	8.3	9.6	11.0	12.4
110	2.2	2.4	2.8	3.2	3.6	4.0	4.5	5.0	5.5	6.6	7.8	9.1	10.5	11.9	13.5
115	2.3	2.7	3.0	3.5	3.9	4.4	4.9	5.4	6.0	7.2	8.5	9.9	11.4	13.0	14.8
120	2.5	2.9	3.3	3.8	4.3	4.8	5.4	5.9	6.5	7.9	9.3	10.8	12.5	14.3	16.2

* 20° or 3°/s

** Use the value of 50° for course changes lower than 50°.

**Table III-2-1-3. Minimum stabilization distance between fly-by waypoints
(SI units, 25° bank angle*)**

Course change** (Degrees)	True airspeed (km/h)														
	< or = 240	260	280	300	320	340	360	380	400	440	480	520	560	600	640
50	0.9	1.0	1.1	1.2	1.3	1.4	1.5	1.7	1.8	2.1	2.5	2.8	3.2	3.7	4.1
55	1.0	1.1	1.2	1.2	1.3	1.5	1.6	1.8	2.0	2.3	2.7	3.1	3.5	4.0	4.5
60	1.1	1.2	1.2	1.3	1.4	1.6	1.8	1.9	2.1	2.5	2.9	3.4	3.8	4.3	4.9
65	1.1	1.2	1.3	1.4	1.5	1.7	1.9	2.1	2.3	2.7	3.1	3.6	4.1	4.7	5.3
70	1.2	1.3	1.4	1.5	1.7	1.8	2.0	2.2	2.4	2.9	3.4	3.9	4.5	5.1	5.7
75	1.3	1.4	1.5	1.6	1.8	2.0	2.2	2.4	2.6	3.1	3.6	4.2	4.8	5.5	6.2
80	1.4	1.5	1.6	1.8	1.9	2.1	2.3	2.6	2.8	3.4	3.9	4.6	5.2	5.9	6.7
85	1.5	1.6	1.8	1.9	2.0	2.3	2.5	2.8	3.0	3.6	4.2	4.9	5.6	6.4	7.2
90	1.6	1.7	1.9	2.0	2.2	2.4	2.7	3.0	3.3	3.9	4.6	5.3	6.1	6.9	7.8
95	1.7	1.9	2.0	2.2	2.3	2.6	2.9	3.2	3.5	4.2	4.9	5.7	6.6	7.5	8.4
100	1.9	2.0	2.2	2.3	2.5	2.8	3.1	3.4	3.8	4.5	5.3	6.2	7.1	8.1	9.1
105	2.0	2.2	2.3	2.5	2.7	3.0	3.3	3.7	4.1	4.9	5.7	6.7	7.7	8.7	9.9
110	2.2	2.3	2.5	2.7	2.9	3.3	3.6	4.0	4.4	5.3	6.2	7.2	8.3	9.5	10.8
115	2.3	2.5	2.7	2.9	3.2	3.5	3.9	4.4	4.8	5.7	6.8	7.9	9.1	10.4	11.7
120	2.5	2.7	3.0	3.2	3.4	3.9	4.3	4.7	5.2	6.3	7.4	8.6	9.9	11.4	12.9

* 25° or 3°/s

** Use the value of 50° for course changes lower than 50°.

**Table III-2-1-4. Minimum stabilization distance between flyover waypoints
(SI units, 15° bank angle)**

Course change* (Degrees)	True airspeed (km/h)														
	< or = 240	260	280	300	320	340	360	380	400	440	480	520	560	600	640
50	3.9	4.5	5.2	5.9	6.7	7.5	8.3	9.2	10.1	12.1	14.3	16.7	19.2	22.0	24.9
55	4.2	4.9	5.6	6.4	7.2	8.0	9.0	9.9	10.9	13.1	15.5	18.1	20.8	23.8	27.0
60	4.5	5.2	6.0	6.8	7.7	8.6	9.6	10.7	11.8	14.1	16.7	19.4	22.4	25.6	29.1
65	4.8	5.6	6.4	7.3	8.2	9.2	10.3	11.4	12.6	15.1	17.9	20.8	24.0	27.5	31.1
70	5.1	5.9	6.8	7.7	8.8	9.8	11.0	12.1	13.4	16.1	19.0	22.2	25.6	29.3	33.2
75	5.4	6.3	7.2	8.2	9.3	10.4	11.6	12.9	14.2	17.1	20.2	23.6	27.2	31.1	35.3
80	5.7	6.6	7.6	8.6	9.8	11.0	12.2	13.6	15.0	18.0	21.3	24.9	28.7	32.9	37.3
85	5.9	6.9	7.9	9.1	10.2	11.5	12.8	14.3	15.7	18.9	22.4	26.2	30.2	34.6	39.2
90	6.2	7.2	8.3	9.5	10.7	12.0	13.4	14.9	16.5	19.8	23.4	27.4	31.6	36.2	41.1
95	6.4	7.5	8.6	9.9	11.2	12.5	14.0	15.5	17.2	20.6	24.4	28.6	33.0	37.8	42.9
100	6.7	7.8	9.0	10.2	11.6	13.0	14.5	16.1	17.8	21.4	25.4	29.7	34.3	39.2	44.5
105	6.9	8.0	9.3	10.6	12.0	13.4	15.0	16.7	18.4	22.2	26.2	30.7	35.5	40.6	46.1
110	7.1	8.3	9.5	10.9	12.3	13.8	15.5	17.2	19.0	22.8	27.0	31.6	36.6	41.8	47.5
115	7.3	8.5	9.8	11.2	12.6	14.2	15.9	17.6	19.5	23.4	27.8	32.5	37.5	43.0	48.8
120	7.4	8.7	10.0	11.4	12.9	14.5	16.2	18.0	19.9	24.0	28.4	33.2	38.4	44.0	49.9

* Use the value of 50° for course changes lower than 50°.

**Table III-2-1-5. Minimum stabilization distance between flyover waypoints
(SI units, 20° bank angle*)**

Course change** (Degrees)	True airspeed (km/h)														
	< or = 240	260	280	300	320	340	360	380	400	440	480	520	560	600	640
50	3.2	3.7	4.2	4.8	5.4	6.0	6.6	7.3	8.1	9.7	11.4	13.2	15.2	17.4	19.6
55	3.4	3.9	4.5	5.1	5.7	6.4	7.1	7.9	8.7	10.4	12.2	14.2	16.4	18.7	21.2
60	3.7	4.2	4.8	5.4	6.1	6.9	7.6	8.4	9.3	11.1	13.1	15.3	17.6	20.1	22.7
65	3.9	4.4	5.1	5.8	6.5	7.3	8.1	9.0	9.9	11.8	14.0	16.3	18.8	21.4	24.2
70	4.1	4.7	5.4	6.1	6.9	7.7	8.6	9.5	10.5	12.6	14.8	17.3	19.9	22.8	25.8
75	4.3	4.9	5.7	6.4	7.3	8.1	9.1	10.0	11.1	13.3	15.7	18.3	21.1	24.1	27.3
80	4.5	5.2	5.9	6.8	7.6	8.6	9.5	10.6	11.7	14.0	16.5	19.3	22.2	25.4	28.8
85	4.7	5.4	6.2	7.1	8.0	9.0	10.0	11.1	12.2	14.7	17.3	20.2	23.3	26.6	30.2
90	4.9	5.6	6.5	7.4	8.3	9.4	10.4	11.6	12.7	15.3	18.1	21.1	24.4	27.8	31.6
95	5.1	5.9	6.7	7.7	8.7	9.7	10.8	12.0	13.3	15.9	18.8	22.0	25.4	29.0	32.9
100	5.3	6.1	7.0	7.9	9.0	10.1	11.2	12.4	13.7	16.5	19.5	22.8	26.3	30.1	34.1
105	5.5	6.2	7.2	8.2	9.3	10.4	11.6	12.9	14.2	17.0	20.2	23.5	27.2	31.1	35.2
110	5.6	6.4	7.4	8.4	9.5	10.7	11.9	13.2	14.6	17.5	20.7	24.2	28.0	32.0	36.3
115	5.8	6.6	7.6	8.6	9.7	10.9	12.2	13.6	15.0	18.0	21.3	24.8	28.7	32.8	37.2
120	5.9	6.7	7.7	8.8	10.0	11.2	12.5	13.8	15.3	18.4	21.7	25.4	29.3	33.5	38.1

* 20° or 3°/s

** Use the value of 50° for course changes lower than 50°.

**Table III-2-1-6. Minimum stabilization distance between flyover waypoints
(SI units, 25° bank angle*)**

Course change** (Degrees)	True airspeed (km/h)														
	< or = 240	260	280	300	320	340	360	380	400	440	480	520	560	600	640
50	3.2	3.5	3.8	4.2	4.5	5.1	5.6	6.2	6.8	8.1	9.6	11.1	12.8	14.5	16.4
55	3.4	3.8	4.1	4.4	4.8	5.4	6.0	6.6	7.3	8.7	10.2	11.9	13.7	15.6	17.6
60	3.7	4.0	4.4	4.7	5.1	5.8	6.4	7.1	7.8	9.3	10.9	12.7	14.6	16.6	18.8
65	3.9	4.3	4.6	5.0	5.5	6.1	6.8	7.5	8.2	9.8	11.6	13.5	15.5	17.7	20.0
70	4.1	4.5	4.9	5.3	5.7	6.4	7.2	7.9	8.7	10.4	12.3	14.3	16.4	18.8	21.2
75	4.3	4.7	5.1	5.5	6.0	6.8	7.5	8.3	9.2	11.0	12.9	15.1	17.3	19.8	22.4
80	4.5	5.0	5.4	5.8	6.3	7.1	7.9	8.7	9.6	11.5	13.6	15.8	18.2	20.8	23.5
85	4.7	5.2	5.6	6.1	6.6	7.4	8.2	9.1	10.1	12.0	14.2	16.6	19.1	21.8	24.7
90	4.9	5.4	5.9	6.3	6.9	7.7	8.6	9.5	10.5	12.5	14.8	17.3	19.9	22.7	25.7
95	5.1	5.6	6.1	6.6	7.1	8.0	8.9	9.9	10.9	13.0	15.4	17.9	20.7	23.6	26.8
100	5.3	5.8	6.3	6.8	7.4	8.3	9.2	10.2	11.2	13.5	15.9	18.6	21.4	24.5	27.7
105	5.5	6.0	6.5	7.0	7.6	8.5	9.5	10.5	11.6	13.9	16.4	19.2	22.1	25.2	28.6
110	5.6	6.1	6.6	7.2	7.8	8.7	9.7	10.8	11.9	14.3	16.9	19.7	22.7	26.0	29.4
115	5.8	6.3	6.8	7.3	8.0	9.0	10.0	11.1	12.2	14.6	17.3	20.2	23.3	26.6	30.1
120	5.9	6.4	6.9	7.5	8.1	9.1	10.2	11.3	12.4	14.9	17.7	20.6	23.8	27.2	30.8

* 25° or 3°/s

** Use the value of 50° for course changes lower than 50°.

**Table III-2-1-7. Minimum stabilization distance between fly-by waypoints
(Non-SI units, 15° bank angle)**

Course change* (Degrees)	True airspeed (kt)														
	< or = 130	140	150	160	170	180	190	200	210	220	240	260	280	300	340
50	0.6	0.7	0.8	0.9	1.0	1.1	1.2	1.3	1.4	1.5	1.8	2.1	2.4	2.7	3.4
55	0.7	0.7	0.8	0.9	1.1	1.2	1.3	1.4	1.5	1.7	2.0	2.3	2.6	3.0	3.7
60	0.7	0.8	0.9	1.0	1.1	1.3	1.4	1.5	1.7	1.8	2.1	2.5	2.9	3.2	4.1
65	0.8	0.9	1.0	1.1	1.2	1.4	1.5	1.7	1.8	2.0	2.3	2.7	3.1	3.5	4.5
70	0.8	0.9	1.1	1.2	1.3	1.5	1.6	1.8	2.0	2.1	2.5	2.9	3.4	3.8	4.9
75	0.9	1.0	1.1	1.3	1.4	1.6	1.8	1.9	2.1	2.3	2.7	3.2	3.7	4.2	5.3
80	1.0	1.1	1.2	1.4	1.6	1.7	1.9	2.1	2.3	2.5	3.0	3.4	4.0	4.5	5.7
85	1.0	1.2	1.3	1.5	1.7	1.9	2.1	2.3	2.5	2.7	3.2	3.7	4.3	4.9	6.2
90	1.1	1.3	1.4	1.6	1.8	2.0	2.2	2.5	2.7	2.9	3.5	4.0	4.7	5.3	6.8
95	1.2	1.4	1.5	1.7	2.0	2.2	2.4	2.7	2.9	3.2	3.8	4.4	5.0	5.8	7.3
100	1.3	1.5	1.7	1.9	2.1	2.3	2.6	2.9	3.1	3.4	4.1	4.7	5.5	6.2	8.0
105	1.4	1.6	1.8	2.0	2.3	2.5	2.8	3.1	3.4	3.7	4.4	5.2	5.9	6.8	8.7
110	1.5	1.7	2.0	2.2	2.5	2.8	3.1	3.4	3.7	4.1	4.8	5.6	6.5	7.4	9.5
115	1.6	1.9	2.1	2.4	2.7	3.0	3.3	3.7	4.1	4.4	5.3	6.1	7.1	8.1	10.3
120	1.8	2.0	2.3	2.6	3.0	3.3	3.7	4.0	4.4	4.9	5.8	6.7	7.8	8.9	11.4

* Use the value of 50° for course changes lower than 50°.

**Table III-2-1-8. Minimum stabilization distance between fly-by waypoints
(Non-SI units, 20° bank angle*)**

Course change** (Degrees)	True airspeed (kt)														
	< or = 130	140	150	160	170	180	190	200	210	220	240	260	280	300	340
50	0.5	0.6	0.6	0.7	0.8	0.9	0.9	1.0	1.1	1.2	1.4	1.6	1.9	2.1	2.6
55	0.5	0.6	0.7	0.8	0.8	0.9	1.0	1.1	1.2	1.3	1.5	1.8	2.0	2.3	2.9
60	0.6	0.6	0.7	0.8	0.9	1.0	1.1	1.2	1.3	1.4	1.7	1.9	2.2	2.5	3.1
65	0.6	0.7	0.8	0.9	1.0	1.1	1.2	1.3	1.4	1.5	1.8	2.1	2.4	2.7	3.4
70	0.7	0.7	0.8	0.9	1.0	1.2	1.3	1.4	1.5	1.7	1.9	2.3	2.6	2.9	3.7
75	0.7	0.8	0.9	1.0	1.1	1.2	1.4	1.5	1.6	1.8	2.1	2.4	2.8	3.2	4.0
80	0.8	0.9	1.0	1.1	1.2	1.3	1.5	1.6	1.8	1.9	2.3	2.6	3.0	3.4	4.4
85	0.8	0.9	1.0	1.2	1.3	1.4	1.6	1.7	1.9	2.1	2.4	2.8	3.3	3.7	4.7
90	0.9	1.0	1.1	1.2	1.4	1.5	1.7	1.9	2.1	2.2	2.6	3.1	3.5	4.0	5.1
95	0.9	1.1	1.2	1.3	1.5	1.7	1.8	2.0	2.2	2.4	2.8	3.3	3.8	4.3	5.5
100	1.0	1.1	1.3	1.4	1.6	1.8	2.0	2.2	2.4	2.6	3.1	3.6	4.1	4.7	6.0
105	1.1	1.2	1.4	1.6	1.7	1.9	2.1	2.4	2.6	2.8	3.3	3.9	4.5	5.1	6.5
110	1.2	1.3	1.5	1.7	1.9	2.1	2.3	2.6	2.8	3.1	3.6	4.2	4.9	5.6	7.1
115	1.3	1.4	1.6	1.8	2.1	2.3	2.5	2.8	3.1	3.3	4.0	4.6	5.3	6.1	7.7
120	1.4	1.6	1.8	2.0	2.2	2.5	2.8	3.1	3.3	3.7	4.3	5.0	5.8	6.7	8.5

* 20° or 3°/s

** Use the value of 50° for course changes lower than 50°.

**Table III-2-1-9. Minimum stabilization distance between fly-by waypoints
(Non-SI units, 25° bank angle*)**

Course change** (Degrees)	True airspeed (kt)														
	< or = 130	140	150	160	170	180	190	200	210	220	240	260	280	300	340
50	0.5	0.5	0.6	0.6	0.7	0.7	0.8	0.9	0.9	1.0	1.2	1.3	1.5	1.7	2.2
55	0.5	0.6	0.6	0.7	0.7	0.8	0.9	0.9	1.0	1.1	1.3	1.5	1.7	1.9	2.4
60	0.5	0.6	0.7	0.7	0.8	0.8	0.9	1.0	1.1	1.2	1.4	1.6	1.8	2.0	2.6
65	0.5	0.7	0.7	0.8	0.8	0.9	1.0	1.1	1.2	1.3	1.5	1.7	1.9	2.2	2.8
70	0.6	0.7	0.8	0.8	0.9	1.0	1.1	1.2	1.3	1.4	1.6	1.8	2.1	2.4	3.0
75	0.6	0.8	0.8	0.9	0.9	1.0	1.1	1.2	1.3	1.5	1.7	2.0	2.3	2.6	3.2
80	0.7	0.8	0.9	0.9	1.0	1.1	1.2	1.3	1.4	1.6	1.8	2.1	2.4	2.8	3.5
85	0.7	0.9	0.9	1.0	1.1	1.2	1.3	1.4	1.6	1.7	2.0	2.3	2.6	3.0	3.8
90	0.7	0.9	1.0	1.1	1.1	1.3	1.4	1.5	1.7	1.8	2.1	2.5	2.8	3.2	4.1
95	0.8	1.0	1.1	1.1	1.2	1.4	1.5	1.6	1.8	2.0	2.3	2.7	3.1	3.5	4.4
100	0.8	1.1	1.2	1.2	1.3	1.5	1.6	1.8	1.9	2.1	2.5	2.9	3.3	3.8	4.8
105	0.9	1.2	1.2	1.3	1.4	1.6	1.7	1.9	2.1	2.3	2.7	3.1	3.6	4.1	5.2
110	1.0	1.3	1.3	1.4	1.5	1.7	1.9	2.1	2.3	2.5	2.9	3.4	3.9	4.4	5.6
115	1.1	1.4	1.5	1.6	1.7	1.8	2.0	2.2	2.5	2.7	3.2	3.7	4.2	4.8	6.1
120	1.2	1.5	1.6	1.7	1.8	2.0	2.2	2.4	2.7	2.9	3.5	4.0	4.6	5.3	6.7

* 25° or 3°/s

** Use the value of 50° for course changes lower than 50°.

**Table III-2-1-10. Minimum stabilization distance between flyover waypoints
(Non-SI units, 15° bank angle)**

Course change* (Degrees)	True airspeed (kt)														
	< or = 130	140	150	160	170	180	190	200	210	220	240	260	280	300	340
50	2.1	2.4	2.8	3.1	3.5	3.9	4.3	4.7	5.2	5.7	6.7	7.8	9.0	10.2	13.0
55	2.3	2.6	3.0	3.4	3.8	4.2	4.6	5.1	5.6	6.1	7.2	8.4	9.7	11.1	14.1
60	2.4	2.8	3.2	3.6	4.0	4.5	5.0	5.5	6.0	6.6	7.8	9.1	10.4	11.9	15.2
65	2.6	3.0	3.4	3.8	4.3	4.8	5.3	5.9	6.4	7.0	8.3	9.7	11.2	12.8	16.3
70	2.8	3.2	3.6	4.1	4.6	5.1	5.7	6.2	6.9	7.5	8.9	10.3	11.9	13.6	17.4
75	2.9	3.4	3.8	4.3	4.8	5.4	6.0	6.6	7.3	7.9	9.4	11.0	12.7	14.5	18.5
80	3.1	3.5	4.0	4.6	5.1	5.7	6.3	7.0	7.7	8.4	9.9	11.6	13.4	15.3	19.5
85	3.2	3.7	4.2	4.8	5.4	6.0	6.6	7.3	8.0	8.8	10.4	12.2	14.1	16.1	20.5
90	3.4	3.9	4.4	5.0	5.6	6.3	6.9	7.7	8.4	9.2	10.9	12.7	14.7	16.8	21.5
95	3.5	4.0	4.6	5.2	5.8	6.5	7.2	8.0	8.8	9.6	11.4	13.3	15.3	17.5	22.4
100	3.6	4.2	4.8	5.4	6.1	6.8	7.5	8.3	9.1	10.0	11.8	13.8	15.9	18.2	23.3
105	3.7	4.3	4.9	5.6	6.3	7.0	7.8	8.6	9.4	10.3	12.2	14.3	16.5	18.9	24.1
110	3.9	4.4	5.1	5.7	6.4	7.2	8.0	8.8	9.7	10.6	12.6	14.7	17.0	19.4	24.8
115	4.0	4.6	5.2	5.9	6.6	7.4	8.2	9.1	10.0	10.9	12.9	15.1	17.4	20.0	25.5
120	4.0	4.7	5.3	6.0	6.8	7.5	8.4	9.3	10.2	11.1	13.2	15.4	17.8	20.4	26.1

* Use the value of 50° for course changes lower than 50°.

**Table III-2-1-11. Minimum stabilization distance between flyover waypoints
(Non-SI units, 20° bank angle*)**

Course change** (Degrees)	True airspeed (kt)														
	< or = 130	140	150	160	170	180	190	200	210	220	240	260	280	300	340
50	1.7	2.0	2.2	2.5	2.8	3.1	3.4	3.8	4.1	4.5	5.3	6.2	7.1	8.1	10.3
55	1.9	2.1	2.4	2.7	3.0	3.3	3.7	4.1	4.4	4.9	5.7	6.6	7.6	8.7	11.1
60	2.0	2.2	2.5	2.9	3.2	3.6	3.9	4.3	4.8	5.2	6.1	7.1	8.2	9.3	11.9
65	2.1	2.4	2.7	3.0	3.4	3.8	4.2	4.6	5.1	5.5	6.5	7.6	8.7	10.0	12.7
70	2.2	2.5	2.9	3.2	3.6	4.0	4.4	4.9	5.4	5.9	6.9	8.1	9.3	10.6	13.5
75	2.3	2.6	3.0	3.4	3.8	4.2	4.7	5.2	5.7	6.2	7.3	8.5	9.8	11.2	14.3
80	2.5	2.8	3.2	3.6	4.0	4.5	4.9	5.4	6.0	6.5	7.7	9.0	10.3	11.8	15.1
85	2.6	2.9	3.3	3.7	4.2	4.7	5.2	5.7	6.2	6.8	8.1	9.4	10.9	12.4	15.8
90	2.7	3.0	3.4	3.9	4.4	4.9	5.4	5.9	6.5	7.1	8.4	9.8	11.3	13.0	16.5
95	2.8	3.1	3.6	4.0	4.5	5.1	5.6	6.2	6.8	7.4	8.8	10.2	11.8	13.5	17.2
100	2.9	3.3	3.7	4.2	4.7	5.2	5.8	6.4	7.0	7.7	9.1	10.6	12.2	14.0	17.8
105	3.0	3.4	3.8	4.3	4.8	5.4	6.0	6.6	7.3	7.9	9.4	10.9	12.6	14.4	18.4
110	3.0	3.4	3.9	4.4	5.0	5.6	6.2	6.8	7.5	8.2	9.7	11.3	13.0	14.9	19.0
115	3.1	3.5	4.0	4.5	5.1	5.7	6.3	7.0	7.7	8.4	9.9	11.6	13.3	15.3	19.5
120	3.2	3.6	4.1	4.6	5.2	5.8	6.4	7.1	7.8	8.5	10.1	11.8	13.6	15.6	19.9

* 20° or 3°/s

** Use the value of 50° for course changes lower than 50°.

**Table III-2-1-12. Minimum stabilization distance between flyover waypoints
(Non-SI units, 25° bank angle*)**

Course change** (Degrees)	<i>True airspeed (kt)</i>														
	< or = 130	140	150	160	170	180	190	200	210	220	240	260	280	300	340
50	1.7	1.9	2.1	2.2	2.4	2.6	2.9	3.2	3.5	3.8	4.5	5.2	6.0	6.8	8.6
55	1.9	2.0	2.2	2.4	2.5	2.8	3.1	3.4	3.7	4.1	4.8	5.6	6.4	7.3	9.2
60	2.0	2.2	2.3	2.5	2.7	3.0	3.3	3.6	4.0	4.3	5.1	5.9	6.8	7.8	9.9
65	2.1	2.3	2.5	2.7	2.9	3.2	3.5	3.9	4.2	4.6	5.4	6.3	7.2	8.3	10.5
70	2.2	2.4	2.6	2.8	3.0	3.3	3.7	4.1	4.5	4.9	5.7	6.7	7.7	8.7	11.1
75	2.3	2.5	2.7	3.0	3.2	3.5	3.9	4.3	4.7	5.1	6.0	7.0	8.1	9.2	11.7
80	2.5	2.7	2.9	3.1	3.3	3.7	4.1	4.5	4.9	5.4	6.3	7.4	8.5	9.7	12.3
85	2.6	2.8	3.0	3.2	3.5	3.9	4.3	4.7	5.1	5.6	6.6	7.7	8.9	10.1	12.9
90	2.7	2.9	3.1	3.4	3.6	4.0	4.4	4.9	5.4	5.9	6.9	8.0	9.3	10.6	13.5
95	2.8	3.0	3.2	3.5	3.7	4.2	4.6	5.1	5.6	6.1	7.2	8.4	9.6	11.0	14.0
100	2.9	3.1	3.4	3.6	3.9	4.3	4.8	5.2	5.8	6.3	7.4	8.6	10.0	11.4	14.5
105	3.0	3.2	3.5	3.7	4.0	4.4	4.9	5.4	5.9	6.5	7.7	8.9	10.3	11.7	15.0
110	3.0	3.3	3.6	3.8	4.1	4.5	5.0	5.6	6.1	6.7	7.9	9.2	10.6	12.1	15.4
115	3.1	3.4	3.6	3.9	4.2	4.7	5.2	5.7	6.2	6.8	8.1	9.4	10.8	12.4	15.8
120	3.2	3.4	3.7	4.0	4.3	4.8	5.3	5.8	6.4	7.0	8.2	9.6	11.1	12.6	16.1

* 25° or 3°/s

** Use the value of 50° for course changes lower than 50°.

**Table III-2-1-13. Minimum stabilization distance between fly-by waypoints
(SI units, 15° bank angle*)**

<i>Course change** (degrees)</i>	<i>True airspeed (km/h)</i>						
	<i>≤ 130</i>	<i>150</i>	<i>170</i>	<i>190</i>	<i>210</i>	<i>230</i>	<i>240</i>
30	0.29	0.34	0.38	0.44	0.52	0.61	0.65
35	0.33	0.38	0.43	0.49	0.58	0.68	0.73
40	0.36	0.41	0.47	0.54	0.65	0.76	0.82
45	0.39	0.45	0.52	0.60	0.71	0.84	0.90
50	0.43	0.50	0.56	0.65	0.78	0.92	0.99
55	0.47	0.54	0.61	0.71	0.85	1.00	1.08
60	0.51	0.58	0.66	0.77	0.92	1.09	1.18
65	0.55	0.63	0.72	0.83	1.00	1.18	1.28
70	0.59	0.68	0.77	0.90	1.08	1.28	1.38
75	0.64	0.74	0.83	0.97	1.17	1.38	1.50
80	0.69	0.79	0.90	1.05	1.26	1.50	1.62
85	0.74	0.85	0.97	1.13	1.36	1.62	1.75
90	0.80	0.92	1.04	1.22	1.47	1.74	1.89
95	0.86	0.99	1.13	1.32	1.59	1.89	2.05
100	0.93	1.07	1.22	1.42	1.72	2.04	2.22
105	1.01	1.16	1.32	1.54	1.86	2.22	2.40
110	1.09	1.26	1.43	1.67	2.02	2.41	2.62
115	1.19	1.37	1.56	1.82	2.21	2.63	2.85
120	1.30	1.50	1.70	1.99	2.42	2.88	3.13

* 15° or 3°/s

** Use the value 30° for course changes lower than 30°

**Table III-2-1-14. Minimum stabilization distance between fly-by waypoints
(SI units, 20° bank angle*)**

<i>Course change** (degrees)</i>	<i>True airspeed (km/h)</i>						
	<i>≤ 130</i>	<i>150</i>	<i>170</i>	<i>190</i>	<i>210</i>	<i>230</i>	<i>240</i>
30	0.29	0.34	0.38	0.43	0.47	0.52	0.54
35	0.33	0.38	0.43	0.48	0.53	0.58	0.60
40	0.36	0.41	0.47	0.53	0.58	0.64	0.66
45	0.39	0.45	0.52	0.58	0.64	0.70	0.73
50	0.43	0.50	0.56	0.63	0.69	0.76	0.79
55	0.47	0.54	0.61	0.68	0.75	0.83	0.86
60	0.51	0.58	0.66	0.74	0.82	0.90	0.94
65	0.55	0.63	0.72	0.80	0.88	0.97	1.01
70	0.59	0.68	0.77	0.86	0.96	1.05	1.09
75	0.64	0.74	0.83	0.93	1.03	1.13	1.18
80	0.69	0.79	0.90	1.00	1.11	1.22	1.27
85	0.74	0.85	0.97	1.08	1.20	1.31	1.37
90	0.80	0.92	1.04	1.17	1.29	1.41	1.47
95	0.86	0.99	1.13	1.26	1.39	1.52	1.59
100	0.93	1.07	1.22	1.36	1.50	1.65	1.72
105	1.01	1.16	1.32	1.47	1.63	1.78	1.86
110	1.09	1.26	1.43	1.60	1.77	1.93	2.02
115	1.19	1.37	1.56	1.74	1.92	2.11	2.20
120	1.30	1.50	1.70	1.90	2.10	2.31	2.41

* 20° or 3°/s

** Use the value 30° for course changes lower than 30°

**Table III-2-1-15. Minimum stabilization distance between flyover waypoints
(SI units, 15° bank angle*)**

<i>Course change** (degrees)</i>	<i>True airspeed (km/h)</i>						
	<i>≤ 130</i>	<i>150</i>	<i>170</i>	<i>190</i>	<i>210</i>	<i>230</i>	<i>240</i>
30	1.06	1.22	1.38	1.61	1.93	2.29	2.48
35	1.16	1.34	1.52	1.77	2.13	2.53	2.74
40	1.27	1.47	1.66	1.94	2.34	2.78	3.01
45	1.39	1.60	1.81	2.12	2.56	3.04	3.29
50	1.51	1.74	1.97	2.30	2.78	3.30	3.58
55	1.62	1.87	2.12	2.48	3.00	3.57	3.87
60	1.74	2.01	2.28	2.67	3.23	3.84	4.17
65	1.86	2.15	2.44	2.85	3.45	4.11	4.46
70	1.98	2.29	2.59	3.04	3.68	4.38	4.76
75	2.10	2.43	2.75	3.22	3.90	4.65	5.04
80	2.22	2.56	2.90	3.39	4.11	4.90	5.33
85	2.33	2.69	3.04	3.56	4.32	5.16	5.60
90	2.43	2.81	3.18	3.73	4.52	5.40	5.86
95	2.54	2.93	3.32	3.88	4.71	5.62	6.11
100	2.63	3.04	3.44	4.03	4.89	5.84	6.34
105	2.72	3.14	3.56	4.17	5.06	6.04	6.56
110	2.80	3.23	3.66	4.29	5.21	6.22	6.76
115	2.87	3.32	3.76	4.40	5.35	6.39	6.94
120	2.94	3.39	3.84	4.50	5.47	6.53	7.10

* 15° or 3°/s

** Use the value 30° for course changes lower than 30°

**Table III-2-1-16. Minimum stabilization distance between flyover waypoints
(SI units, 20° bank angle*)**

<i>Course change** (degrees)</i>	<i>True airspeed (km/h)</i>						
	<i>≤ 130</i>	<i>150</i>	<i>170</i>	<i>190</i>	<i>210</i>	<i>230</i>	<i>240</i>
30	1.06	1.22	1.38	1.56	1.75	1.96	2.06
35	1.16	1.34	1.52	1.71	1.93	2.14	2.26
40	1.27	1.47	1.66	1.87	2.10	2.34	2.46
45	1.39	1.60	1.81	2.04	2.29	2.54	2.67
50	1.51	1.74	1.97	2.21	2.48	2.75	2.89
55	1.62	1.87	2.12	2.39	2.67	2.96	3.11
60	1.74	2.01	2.28	2.56	2.87	3.18	3.33
65	1.86	2.15	2.44	2.74	3.06	3.39	3.55
70	1.98	2.29	2.59	2.91	3.25	3.60	3.78
75	2.10	2.43	2.75	3.09	3.44	3.81	3.99
80	2.22	2.56	2.90	3.25	3.63	4.01	4.20
85	2.33	2.69	3.04	3.42	3.81	4.21	4.41
90	2.43	2.81	3.18	3.57	3.98	4.40	4.61
95	2.54	2.93	3.32	3.72	4.14	4.58	4.79
100	2.63	3.04	3.44	3.86	4.30	4.74	4.97
105	2.72	3.14	3.56	3.99	4.44	4.90	5.13
110	2.80	3.23	3.66	4.11	4.57	5.05	5.28
115	2.87	3.32	3.76	4.22	4.69	5.18	5.42
120	2.94	3.39	3.84	4.31	4.80	5.29	5.54

* 20° or 3°/s

** Use the value 30° for course changes lower than 30°

**Table III-2-1-17. Minimum stabilization distance between fly-by waypoints
(Non-SI units, 15° bank angle*)**

Course change** (degrees)	True airspeed (kt)						
	≤ 70	80	90	100	110	120	130
30	0.16	0.18	0.20	0.23	0.27	0.31	0.35
35	0.18	0.20	0.23	0.25	0.30	0.35	0.40
40	0.19	0.22	0.25	0.28	0.33	0.39	0.44
45	0.21	0.24	0.27	0.31	0.36	0.42	0.49
50	0.23	0.26	0.30	0.34	0.40	0.47	0.54
55	0.25	0.29	0.32	0.37	0.43	0.51	0.59
60	0.27	0.31	0.35	0.40	0.47	0.55	0.64
65	0.29	0.34	0.38	0.43	0.51	0.60	0.69
70	0.32	0.36	0.41	0.46	0.55	0.65	0.75
75	0.34	0.39	0.44	0.50	0.60	0.70	0.81
80	0.37	0.42	0.48	0.54	0.64	0.76	0.88
85	0.40	0.46	0.51	0.58	0.69	0.82	0.95
90	0.43	0.49	0.55	0.63	0.75	0.88	1.03
95	0.46	0.53	0.60	0.68	0.81	0.95	1.11
100	0.50	0.57	0.64	0.73	0.88	1.03	1.20
105	0.54	0.62	0.70	0.79	0.95	1.12	1.31
110	0.59	0.67	0.76	0.86	1.03	1.22	1.42
115	0.64	0.73	0.82	0.94	1.12	1.33	1.55
120	0.70	0.80	0.90	1.03	1.23	1.46	1.70

* 15° or 3°/s

** Use the value 30° for course changes lower than 30°

**Table III-2-1-18. Minimum stabilization distance between fly-by waypoints
(Non-SI units, 20° bank angle*)**

<i>Course change** (degrees)</i>	<i>True airspeed (kt)</i>						
	<i>≤ 70</i>	<i>80</i>	<i>90</i>	<i>100</i>	<i>110</i>	<i>120</i>	<i>130</i>
30	0.16	0.18	0.20	0.23	0.25	0.27	0.29
35	0.18	0.20	0.23	0.25	0.28	0.30	0.33
40	0.19	0.22	0.25	0.28	0.30	0.33	0.36
45	0.21	0.24	0.27	0.30	0.33	0.36	0.39
50	0.23	0.26	0.30	0.33	0.36	0.40	0.43
55	0.25	0.29	0.32	0.36	0.40	0.43	0.47
60	0.27	0.31	0.35	0.39	0.43	0.47	0.51
65	0.29	0.34	0.38	0.42	0.46	0.51	0.55
70	0.32	0.36	0.41	0.45	0.50	0.55	0.59
75	0.34	0.39	0.44	0.49	0.54	0.59	0.64
80	0.37	0.42	0.48	0.53	0.58	0.63	0.69
85	0.40	0.46	0.51	0.57	0.63	0.68	0.74
90	0.43	0.49	0.55	0.61	0.68	0.74	0.80
95	0.46	0.53	0.60	0.66	0.73	0.79	0.86
100	0.50	0.57	0.64	0.72	0.79	0.86	0.93
105	0.54	0.62	0.70	0.77	0.85	0.93	1.01
110	0.59	0.67	0.76	0.84	0.93	1.01	1.09
115	0.64	0.73	0.82	0.92	1.01	1.10	1.19
120	0.70	0.80	0.90	1.00	1.10	1.20	1.30

* 20° or 3°/s

** Use the value 30° for course changes lower than 30°

**Table III-2-1-19. Minimum stabilization distance between flyover waypoints
(Non-SI units, 15° bank angle*)**

<i>Course change** (degrees)</i>	<i>True airspeed (kt)</i>						
	<i>≤ 70</i>	<i>80</i>	<i>90</i>	<i>100</i>	<i>110</i>	<i>120</i>	<i>130</i>
30	0.57	0.65	0.73	0.83	0.99	1.16	1.35
35	0.63	0.71	0.80	0.91	1.09	1.28	1.49
40	0.69	0.78	0.88	1.00	1.20	1.41	1.64
45	0.75	0.85	0.96	1.09	1.30	1.54	1.79
50	0.81	0.93	1.04	1.18	1.42	1.67	1.95
55	0.87	1.00	1.12	1.28	1.53	1.81	2.10
60	0.94	1.07	1.21	1.37	1.65	1.94	2.27
65	1.00	1.15	1.29	1.47	1.76	2.08	2.43
70	1.07	1.22	1.37	1.56	1.87	2.21	2.58
75	1.13	1.29	1.46	1.65	1.99	2.35	2.74
80	1.19	1.36	1.53	1.74	2.10	2.48	2.89
85	1.25	1.43	1.61	1.83	2.20	2.60	3.04
90	1.31	1.50	1.69	1.92	2.30	2.73	3.18
95	1.37	1.56	1.76	2.00	2.40	2.84	3.32
100	1.42	1.62	1.82	2.07	2.49	2.95	3.45
105	1.46	1.67	1.88	2.14	2.58	3.05	3.56
110	1.51	1.72	1.94	2.21	2.65	3.14	3.67
115	1.55	1.77	1.99	2.26	2.72	3.23	3.77
120	1.58	1.81	2.03	2.31	2.79	3.30	3.86

* 15° or 3°/s

** Use the value 30° for course changes lower than 30°

**Table III-2-1-20. Minimum stabilization distance between flyover waypoints
(Non-SI units, 20° bank angle*)**

Course change** (degrees)	True airspeed (kt)						
	≤ 70	80	90	100	110	120	130
30	0.57	0.65	0.73	0.82	0.91	1.01	1.12
35	0.63	0.71	0.80	0.90	1.00	1.11	1.22
40	0.69	0.78	0.88	0.98	1.10	1.21	1.33
45	0.75	0.85	0.96	1.07	1.19	1.32	1.45
50	0.81	0.93	1.04	1.16	1.29	1.43	1.57
55	0.87	1.00	1.12	1.25	1.39	1.54	1.69
60	0.94	1.07	1.21	1.35	1.50	1.65	1.81
65	1.00	1.15	1.29	1.44	1.60	1.76	1.93
70	1.07	1.22	1.37	1.53	1.70	1.87	2.05
75	1.13	1.29	1.46	1.62	1.80	1.98	2.16
80	1.19	1.36	1.53	1.71	1.90	2.09	2.28
85	1.25	1.43	1.61	1.79	1.99	2.19	2.39
90	1.31	1.50	1.69	1.88	2.08	2.29	2.50
95	1.37	1.56	1.76	1.95	2.17	2.38	2.60
100	1.42	1.62	1.82	2.03	2.25	2.47	2.69
105	1.46	1.67	1.88	2.10	2.32	2.55	2.78
110	1.51	1.72	1.94	2.16	2.39	2.63	2.86
115	1.55	1.77	1.99	2.21	2.45	2.69	2.94
120	1.58	1.81	2.03	2.26	2.51	2.75	3.00

* 20° or 3°/s

** Use the value 30° for course changes lower than 30°

**Table III-2-1-21. Minimum length of an RNAV segment limited
by at least one waypoint which is not a turning waypoint**

Phase of flight	D: minimum distance to waypoint*
En-route More than 56 km (30 NM) from departure or destination ARP	9.3 km (5.0 NM)
STARs, Initial within 56 km (30 NM) of the ARP	5.6 km (3.0 NM)
SID within 28 km (15 NM) from DER, intermediate and final approach	2.8 km (1.5 NM)
Missed approaches and SIDs within 56 km (30 NM) of the ARP	5.6 km (3.0 NM)

* When the stabilization distance is greater than D, D is equal to the stabilization distance.

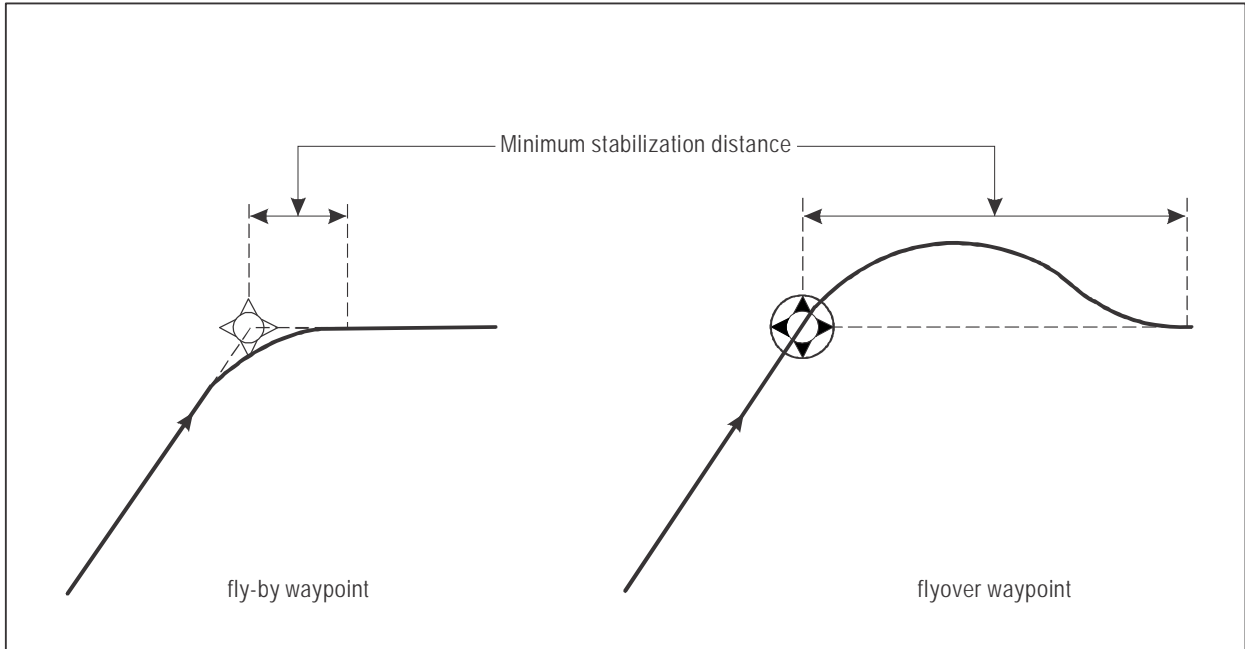

Figure III-2-1-1. Determining the minimum stabilization distance

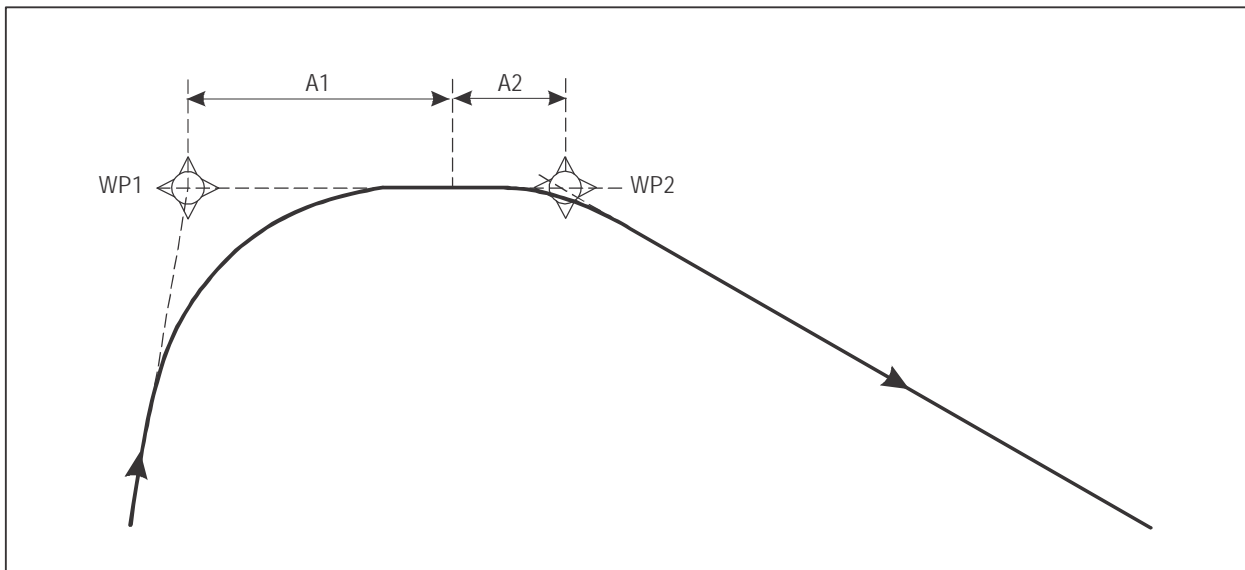

Figure III-2-1-2. Two fly-by waypoints

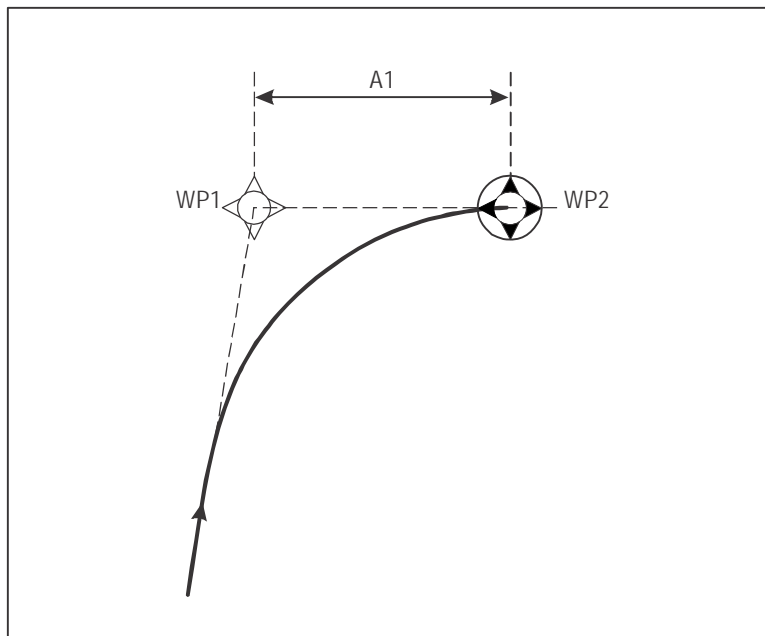

Figure III-2-1-3. Fly-by, then flyover waypoint

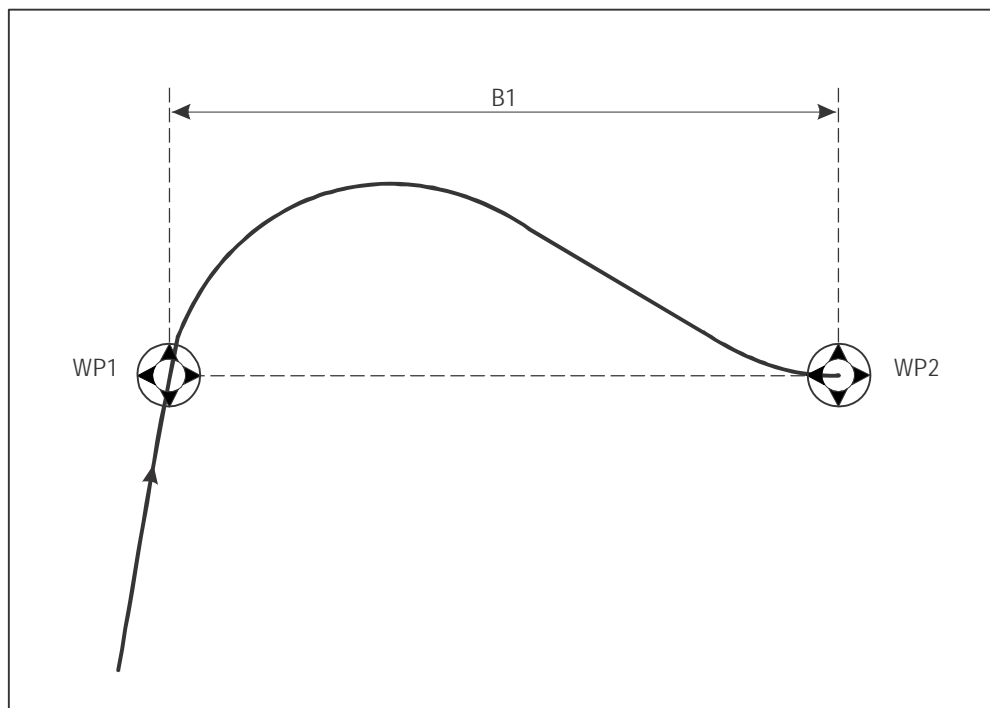

Figure III-2-1-4. Two flyover waypoints

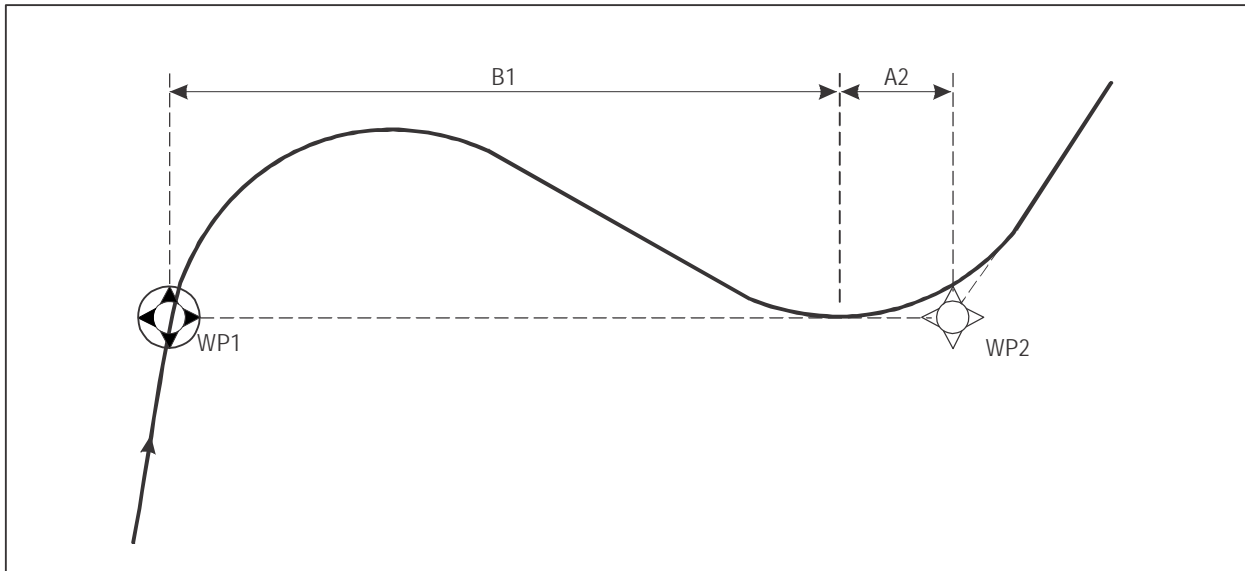

Figure III-2-1-5. Flyover, then fly-by waypoint

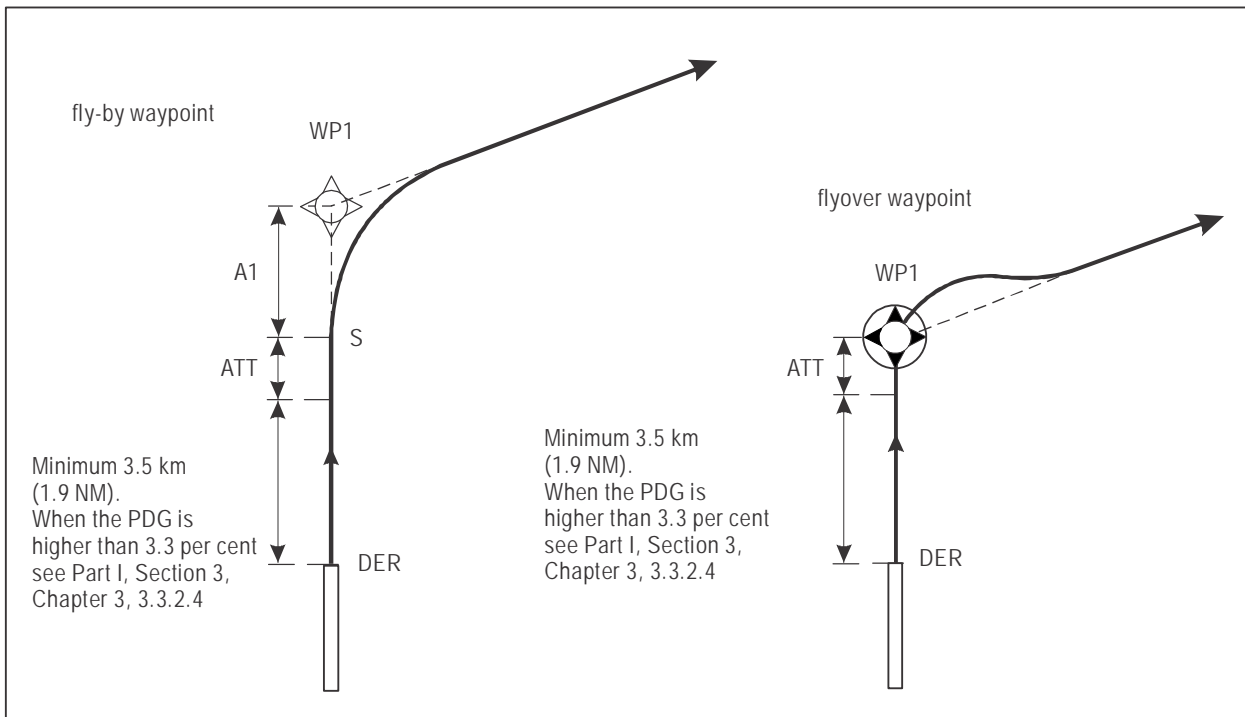

Figure III-2-1-6. Minimum stabilization distance, DER — first waypoint

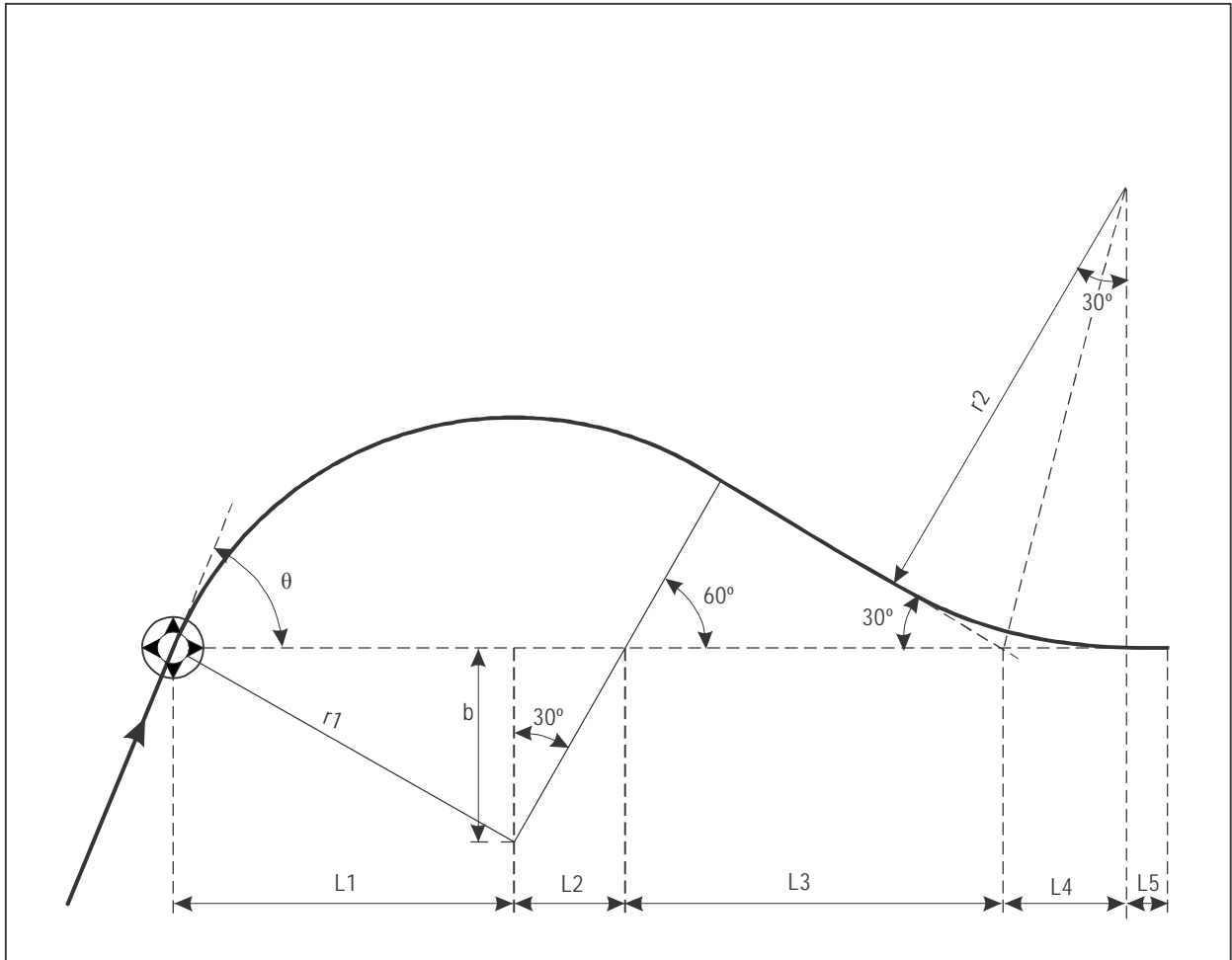

Figure III-2-1-7. Minimum stabilization distance — flyover waypoint

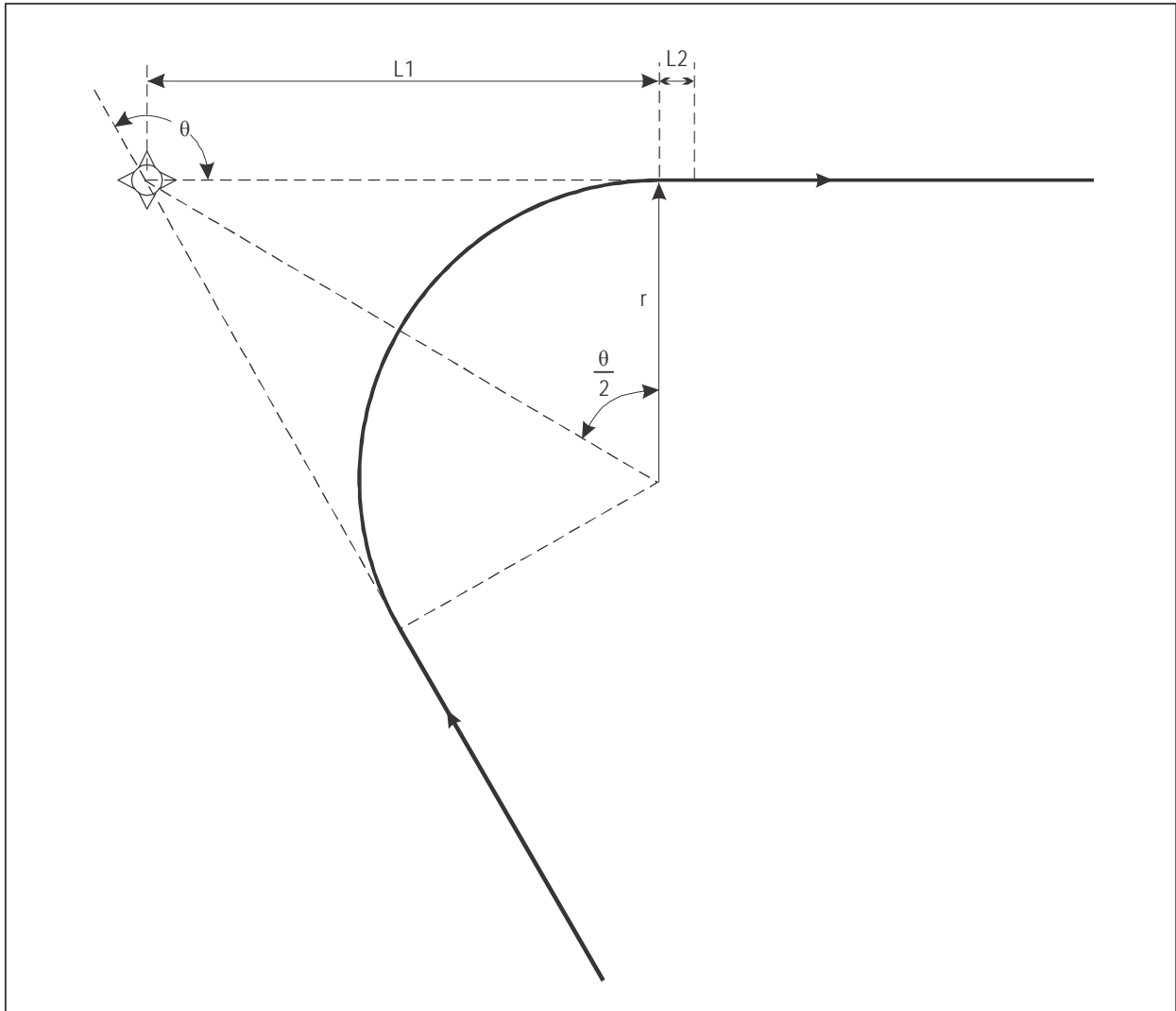

Figure III-2-1-8. Minimum stabilization distance — fly-by waypoint

Chapter 2

TURN PROTECTION AND OBSTACLE ASSESSMENT

2.1 GENERAL

2.1.1 This chapter provides the basic criteria that shall be used in the protection of turns for all RNAV and RNP procedures. Illustrations of the application of the criteria for different waypoint types and path terminators are provided at the end of the chapter. The general criteria defined in Part I, Section 2, Chapter 3 apply as amplified or modified by the criteria in this chapter.

Note.— For turns during a phase of flight where en-route criteria apply, simplified turn criteria, as defined in Section 3, Chapter 8 may be applied in place of the provisions of this chapter.

2.1.2 Speed

The maximum speed and the minimum speed defined for the relevant phase of flight shall be considered in all RNAV and RNP turn constructions.

2.1.3 Turn construction methods

2.1.3.1 Depending on the type of turn, turn angle and segment of flight, different methods of turn protection shall be employed.

2.1.3.2 *Turn at a turning point (TP).* A turn at a turning point can be defined by either a fly-by waypoint or a flyover waypoint. For each type of waypoint, two different turn construction methods shall be employed, depending on the turn angle and segment of flight:

- a) The wind spiral/bounding circles method shall be used for:
 - 1) turns greater than 30° at an IAF or an IF,
 - 2) turns greater than 10° at the FAF,
 - 3) turns inside a missed approach or departure segment.

Note.— The bounding circles method is a simplified method which can be used as an alternative to wind spirals.

The construction is described in 2.3.

- b) The circular arc method shall be used for:
 - 1) turns smaller than or equal to 30° at an IAF or an IF, or

- 2) smaller than or equal to 10° at the FAF.

The construction is described in 2.2.

2.1.3.3 *Turn at an altitude/height (TA/H turn)*. For the TA/H turn, the wind spiral/bounding circles method shall be used. The construction is described in 2.3.

2.1.3.4 *Radius to fix turn (RF turn)*. RF turns apply to RNAV and RNP procedures and are constructed by a different method than for fly-by, flyover or TA/H turns, The construction is described in 2.4.

2.2 CIRCULAR ARC METHOD

2.2.1 General

As the circular arc method is only applied inside segments of flight where flyover waypoints are discouraged (initial approach segment, IF and FAF) this method will normally be applied to fly-by turns only. However, when a flyover turn is implemented inside an initial approach segment, this construction method may also be applied because of the small turn angle.

2.2.2 Protection of the outer turn boundary

The outer edges of the respective primary and secondary areas of the previous and next legs are joined by circular arcs. The boundary points to be joined are located on the perpendiculars to the respective legs drawn from the waypoint to the outer edges. Each circular arc is centred on the point where the perpendicular bisector of the straight line between the two respective boundary points intersects the perpendicular of the previous leg. See Figure III-2-2-1.

Note.— When the area widths of the previous and next legs are the same, the centre of the circular arcs will be at the waypoint.

2.2.3 Protection of the inner turn boundary

The inner turn boundary is defined by joining the respective primary and secondary areas before and after the waypoint. The point of intersection of the edge of the primary area of the previous leg, on the inside of the turn, with the perpendicular to the next leg drawn from the waypoint, is connected by a straight line to the point of intersection of the edge of the primary area of the next leg with the perpendicular to the previous leg, drawn from the waypoint. The same method is applied to join the edge of the secondary areas on the inside of the turn. See Figure III-2-2-1.

2.3 WIND SPIRAL/BOUNDING CIRCLES METHOD

2.3.1 Protection of the outer turn boundary

2.3.1.1 *Primary area*. The most adverse wind spiral boundary shall be used for the outside protection. This may involve the use of up to three wind spirals. There are two cases for connecting the primary area resulting from the wind spiral to the primary area of the next leg:

- a) if the primary area resulting from the wind spiral falls within the primary area of the next leg, these areas shall be joined by a line at 15° to the nominal track of the next leg tangent to the wind spiral. See Figures III-2-2-6, III-2-2-7, III-2-2-9, III-2-2-10, III-2-2-11 and III-2-2-12; and

Note.— In the case of a DF leg, the track to consider is the latest track defined by a line drawn from the next waypoint tangent to the most adverse wind spiral issued from the primary area. See Figures III-2-2-6, III-2-2-7, III-2-2-9, III-2-2-10 and III-2-2-11.

- b) if the resulting primary area falls outside the primary area of the next leg, these areas shall be joined by a line at 30° to the nominal track of the next leg tangent to the wind spiral. See Figures III-2-2-2, III-2-2-3, III-2-2-4, III-2-2-5 and III-2-2-8.

2.3.1.2 Additionally, for fly-by turns, in order to protect the aircraft within the required range of speeds, the outer limit of the primary area is extended as follows:

- a) for turns smaller or equal to 90° the primary area is extended by a parallel to the inbound track and a parallel to the subsequent segment tangent to the wind spiral defined for maximum speed. See Figures III-2-2-2 and III-2-2-5; and
- b) for turns greater than 90° the primary area is extended by a parallel and a perpendicular to the inbound track tangent to the wind spiral defined for maximum speed. See Figure III-2-2-4.

2.3.1.3 *Secondary area.* The secondary area shall be applied to all turns, provided that the secondary area exists at the turning point. The secondary area has a constant width during the turn that is equal to the area width of the secondary area at the latest turning point. If the boundary of the secondary area associated with the turn remains inside the corresponding protection area associated with the subsequent segment, then the boundary splays at an angle of 15° from the nominal track after the turn.

2.3.1.4 *Converging protection area.* If the protection area converges towards a waypoint and the latest turning point is located after the waypoint, the protection area shall retain the value of the area-width at the waypoint until the latest turning point. See Figure III-2-2-3.

2.3.2 Protection of inner turn boundary

The following rules shall apply to protection of the inside of the turn:

- a) if the edge of the primary/secondary area of the previous leg (at the earliest turning point) lies within the primary/secondary area of the next leg, the primary/secondary edge shall be splayed at 15° to the nominal track of the next leg from the most constraining earliest turning point. See Figures III-2-2-3, III-2-2-6, III-2-2-7, III-2-2-9, III-2-2-10, III-2-2-11 and III-2-2-12; and

Note.— In the case of a DF leg, the track to consider is the earliest track defined by a line drawn from the next waypoint to the most constraining earliest turning point at the outside of the primary area. See Figures III-2-2-6, III-2-2-7, III-2-2-9, III-2-2-10 and III-2-2-11.

- b) if the edge of the primary/secondary area of the previous leg (at the earliest turning point) lies outside the primary/secondary area of the next leg, the primary/secondary edge shall be joined at A/2 to the nominal track of the next leg from the most constraining earliest turning point. See Figures III-2-2-2, III-2-2-3, III-2-2-4, III-2-2-5 and III-2-2-8.

2.3.3 Determination of earliest and latest turning point

2.3.3.1 The location of the earliest and latest turning points shall be defined depending on waypoint type/turn application as detailed in Table III-2-2-1.

2.3.3.2 *Turn parameters.* The turn parameters to determine the earliest and latest turning point can be found in the general criteria, Part I, Section 2, Chapter 3, 3.1.2, “Turn parameters” except for the turn initiation distance, which is specific to fly-by RNAV turn. This parameter is defined as:

For earliest turning point determination: Turn initiation distance = $r \tan \frac{A}{2}$;

For latest turning point determination: Turn initiation distance = $\text{Min} [r \tan \frac{A}{2}, r]$.

Where A is the track angle change and r is the radius of turn.

2.4 RF TURN METHOD

2.4.1 General

2.4.1.1 A radius to fix (RF) turn is a constant radius circular path (see Figure III-2-2-13) defined by the:

- a) tangential point at the end of the turn;
- b) centre of the turn; and
- c) turn radius.

2.4.1.2 The value of the turn radius for arrival, approach and departure phases of flight is determined as follows:

$$r = (V + V_w)^2 / (127094 \cdot \tan \theta) \quad r \text{ in km; } V \text{ and } V_w \text{ in km/h}$$

$$r = (V + V_w)^2 / (68626 \cdot \tan \theta) \quad r \text{ in NM; } V \text{ and } V_w \text{ in kt}$$

Where:

V is the aircraft maximum true airspeed in the highest point of the turn

V_w is the maximum wind speed at the highest point in the turn

θ is the bank angle necessary to define the desired track (≤25°).

2.4.1.3 *Maximum TAS.* The maximum TAS should be based upon the IAS for the maximum height during the turn, corrected for the maximum deviation from the ISA value for the aerodrome.

2.4.1.4 *Maximum wind speed.* Maximum wind speed is defined as the ICAO standard wind or, where statistical wind data are available, the maximum wind speed within 95 per cent probability on an omni-directional basis. If no statistical wind data are available, the following values may be applied on SIDs and missed approaches:

- 19 km/h (10 kt) at or below 152 m (500 ft) above AD elevation
- 37 km/h (20 kt) from 152 m (500 ft) to at or below 305 m (1 000 ft) above AD elevation
- 56 km/h (30 kt) from 305 m (1 000 ft) to at or below 610 m (2 000 ft) above AD elevation
- 74 km/h (40 kt) from 610 m (2 000 ft) to at or below 915 m (3 000 ft) above AD elevation

2.4.1.5 To calculate the altitude at the end of an RF leg, for TAS and wind, the distance flown is the arc length between the two waypoints defined by the nominal radius.

2.4.1.6 Speed limitations during the turn, if applicable, shall be applied at the end of the RF leg for SIDs/missed approaches and at the beginning for STARs and approaches.

2.4.1.7 Bank angle. Bank angles up to 25° may be used for any turn above 400 ft above A/D elevation. Turns shall not be initiated below 400 ft above AD elevation.

2.4.1.8 To calculate the height of the OIS for obstacles on an RF leg in a departure or missed approach, the distance is based on an arc length with a radius of $(r - 186 \text{ m}) [(r - 0.1 \text{ NM})]$.

2.4.1.9 The area semi-width is based upon the XTT and the BV, as detailed in Part III, Section 1, Chapters 1 and 2, and further modified as detailed in the paragraphs below.

2.4.1.10 The turn radius shall not be smaller than:

- a) 2 x RNP value of the inbound and outbound segments.
- b) $\frac{1}{2}$ AW of the inbound and outbound segments.

2.4.2 Protection of the outer turn boundary

2.4.2.1 *Primary area.* The outer edge of the primary area is defined by the segment of a circle:

- a) centred on point O (centre of the turn);
- b) having a radius of $r + 0.75 \cdot \text{XTT} + \text{BV}/2 + 93 \text{ m}$ (0.05 NM); and
- c) delimited by the edges of the adjacent straight segments (points A and C in Figure III-2-2-13).

2.4.2.2 *Secondary area.* The outer edge of the secondary area is defined by a segment of a circle:

- a) centred on point O;
- b) having a radius of $r + 1.5 \cdot \text{XTT} + \text{BV} + 186 \text{ m}$ (0.1 NM);
- c) delimited by the edges of the adjacent straight segments (points B and D in Figure III-2-2-13).

2.4.3 Protection of the inner turn boundary

2.4.3.1 *Primary area.* The inner edge of the primary area of a turn is defined by the segment of a circle:

- a) centred on point O;
- b) having a radius of $r - [0.75 \cdot \text{XTT} + \text{BV}/2]$; and
- c) delimited by the edges of the adjacent straight segments.

2.4.3.2 *Secondary area.* The outer edge of the secondary area is defined by a segment of a circle:

- a) centred on point O;
- b) having a radius $r - [1.5 \cdot \text{XTT} + \text{BV}]$;
- c) delimited by the edges of the adjacent straight segments.

2.4.4 Splays in RF turns

2.4.4.1 In a departure or a missed approach where the splay has not been completed before the start of an RF turn, a spiral arc shall be continued on the outside of the turn from the latest ATT plus 3 seconds of flight at the edge of the splay in accordance with the following formula:

$$r_t = r_s + \left(2\pi r_s \frac{\alpha}{360} \right) \tan 15^\circ$$

Where:

$r_{t,\text{outer}}$ is the outer spiral radius of the arc

$r_{s,\text{outer}}$ is the distance from the turn centre to the edge of the outer linear splay at the start of the RF

α is the number of degrees track angle change completed.

2.4.4.2 The outer spiral arc shall start at a distance from the waypoint at the start of the RF turn, corresponding to the latest ATT plus 3 seconds of flight (pilot reaction time at the nominal TAS plus tailwind. It shall terminate when the required $\frac{1}{2}$ AW ($r + 1.5 \text{ XTT} + \text{BV} + 0.1$) is reached or 15° before the succeeding waypoint, when the 15° splay will continue on the subsequent leg. This illustrated in Figure III-2-2-14.

2.4.4.3 The inside of the turn shall also continue to splay in accordance with the following formula:

$$r_t = r_s - \left(2\pi r_s \frac{\alpha}{360} \right) \tan 15^\circ$$

Where:

$r_{t,\text{inner}}$ is the inner spiral radius of the arc

$r_{s,\text{inner}}$ is the distance from the turn centre to the edge of the inner linear splay at the start of the RF

α is the number of degrees track angle change completed.

The inner spiral arc shall start prior to the waypoint at the start of the RF turn, at a distance corresponding to the earliest ATT. It shall terminate when the required $\frac{1}{2}$ AW ($r - [1.5 \text{ XTT} + \text{BV}]$) is reached or 15° after the succeeding waypoint, when the 15° splay will continue on the subsequent leg. This is illustrated in Figure III-2-2-14.

2.5 OBSTACLE ASSESSMENT

2.5.1 *Identification of K K' line.* Line KK' is perpendicular to the flight track of the inbound leg and is located at the earliest turning point. It defines the end of the straight segment before the turn and is used for the measurement of distances to obstacles. In climbing turns (departures and missed approach), the distance measured is always the shortest distance from the earliest start of turn to the obstacle.

2.5.2 *Identification of NN'N" line.* Line NN'N" is the earliest descent fix. For turns at a fly-by waypoint, where a stepdown fix has been defined, the earliest descent fix is not collocated with the earliest turning point. The NN' line is

constructed perpendicular to the previous leg at a distance equal to ATT prior to the waypoint. The N'N" line is offset from the bisector by a distance equal to ATT in the direction of the previous leg, measured perpendicular to the bisector. N' marks the intersection between the two lines. The distance to the obstacle from the earliest descent is measured from the NN'N" line perpendicular to the bisector. See Figures III-2-2-2, III-2-2-4 and III-2-2-5.

2.5.3 Obstacles that are close-in, located at a distance $d_o \leq 9.3$ km (5.0 NM), need not be considered in the determination of the minimum altitude/height (MA/H) of the segment after the fly-by waypoint when the elevation of the obstacle is less than or equal to:

$$\text{Max. Elev}_{\text{Obst}} \leq \text{OCA} - \text{MOC} - d_o \times 0.15$$

where:

- d_o = distance of the obstacle to the NN'N" line measured perpendicularly to the bisector of the turn
- MOC = MOC of the primary area of the segment before the waypoint
- OCA = obstacle clearance altitude of the segment before the waypoint

Table III-2-2-1. Earliest and latest turning point definition

<i>Waypoint type</i>	<i>Earliest and latest turning point criteria</i>
Flyover (Figures III-2-2-3, III-2-2-6 and III-2-2-7)	Earliest: ATT before the waypoint. Latest: ATT + pilot reaction time + bank angle delay.
Fly-by (Figures III-2-2-2, III-2-2-4 and III-2-2-5)	Earliest: ATT+ turn initiation distance before the waypoint. Latest: Turn initiation distance – ATT – pilot reaction time (if the value is negative, the point is beyond the waypoint).
TA/H departure followed by a CF leg (Figure III-2-2-8)	Earliest: 600 m from the start end of the runway (the start of the runway available for take-off/TORA). Latest: The point at which the surface, beginning at 5 m above the DER, reaches the required altitude, at the prescribed PDG + pilot reaction time + bank angle delay.
TA/H departure followed by a DF leg (Figure III-2-2-9)	Earliest: 600 m from the start end of the runway (the start of the runway available for take-off/TORA). Latest: The point at which the surface, beginning at 5 m above the DER, reaches the required altitude, at the prescribed PDG + pilot reaction time + bank angle delay.
TA/H missed approach (Figure III-2-2-10)	Earliest: ATT before the MAPt. (The normal case is that the aircraft does not turn before the MAPt even when well above required altitude. A note is required to this effect on the IAC.) Latest: The point at which the surface, beginning at the SOC, reaches the required altitude, at a 2.5% climb gradient unless otherwise stated + pilot reaction time + bank angle delay.
Turn at the MAPt (Figure III-2-2-11 and III-2-2-12)	Earliest: ATT before the MAPt. Latest: SOC + pilot reaction time + bank angle delay.

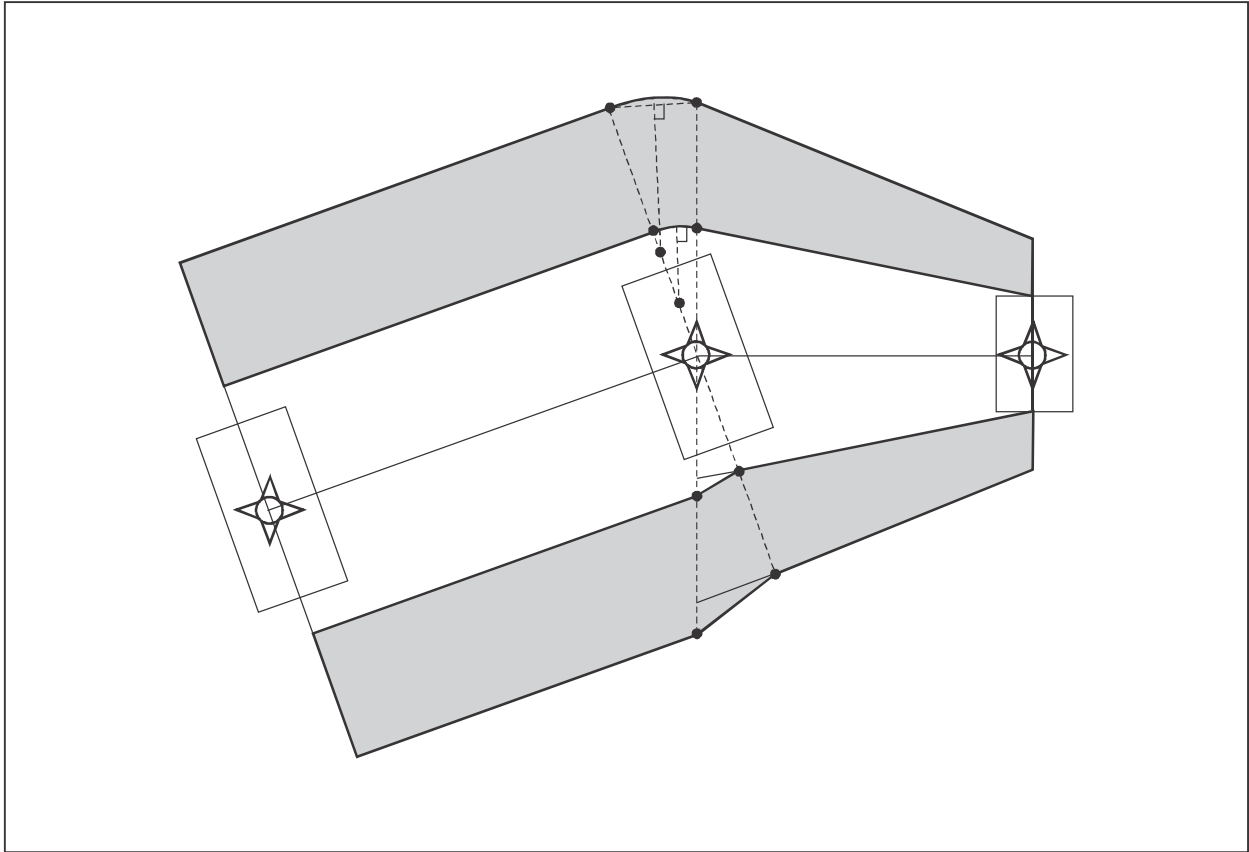

Figure III-2-2-1. Small turn angle — circular arc method

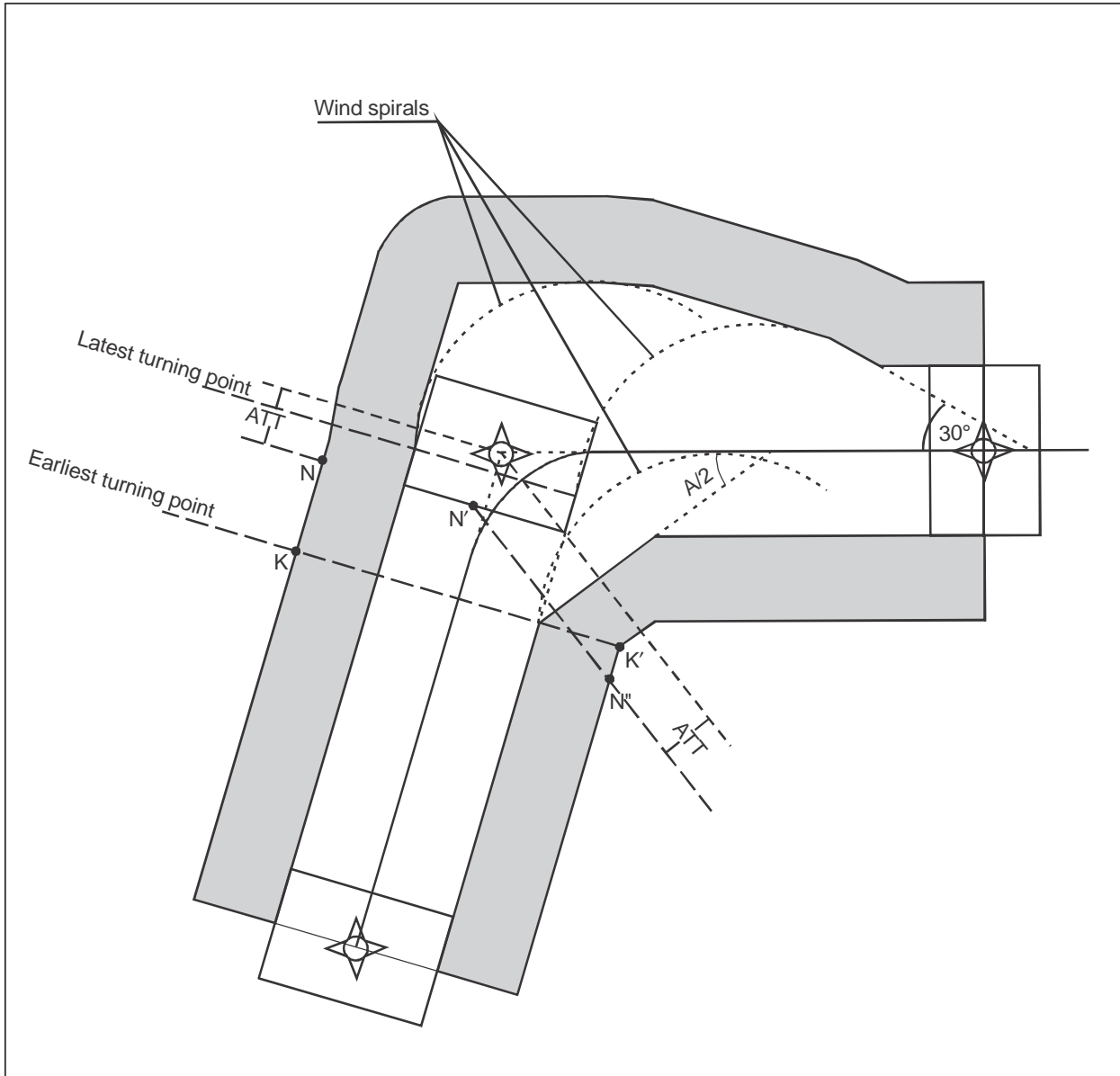

Figure III-2-2. Fly-by turn — primary/secondary areas outside of turn

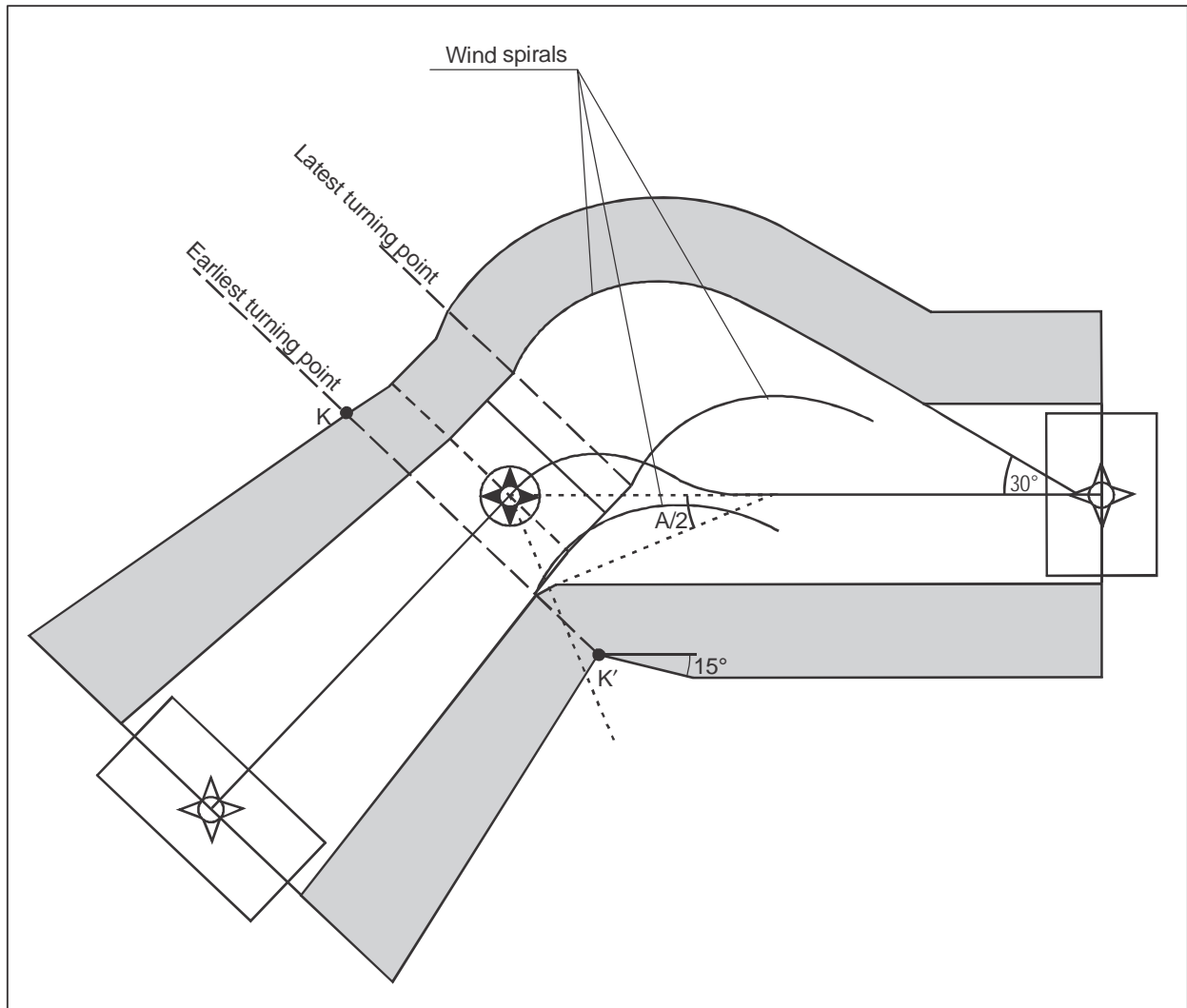

Figure III-2-2-3. Flyover turn with a TF leg after the turn — secondary area inside, on inner side of turn

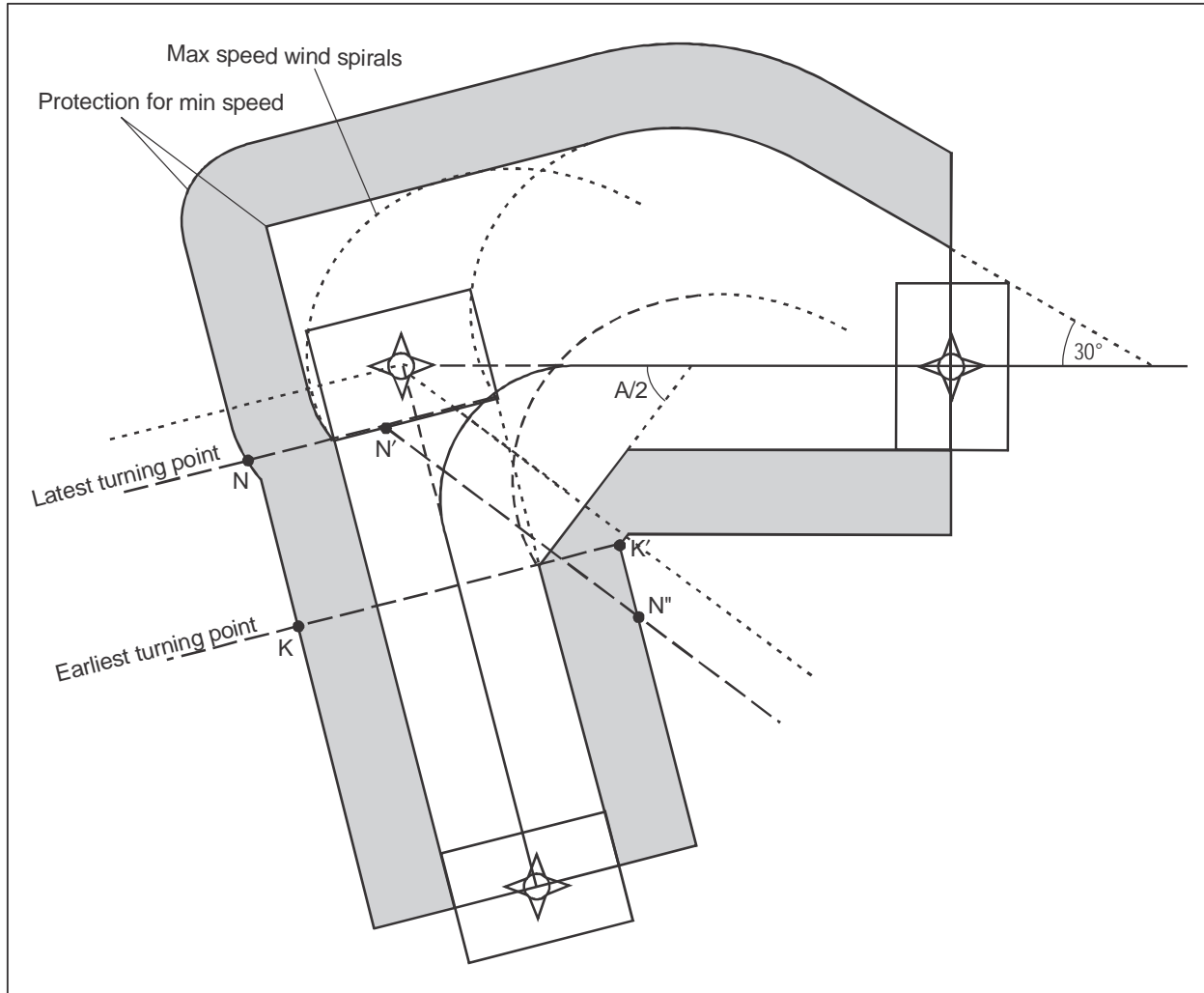

Figure III-2-2-4. NN'N'' Line — Fly-by turn with turn angle > 90°

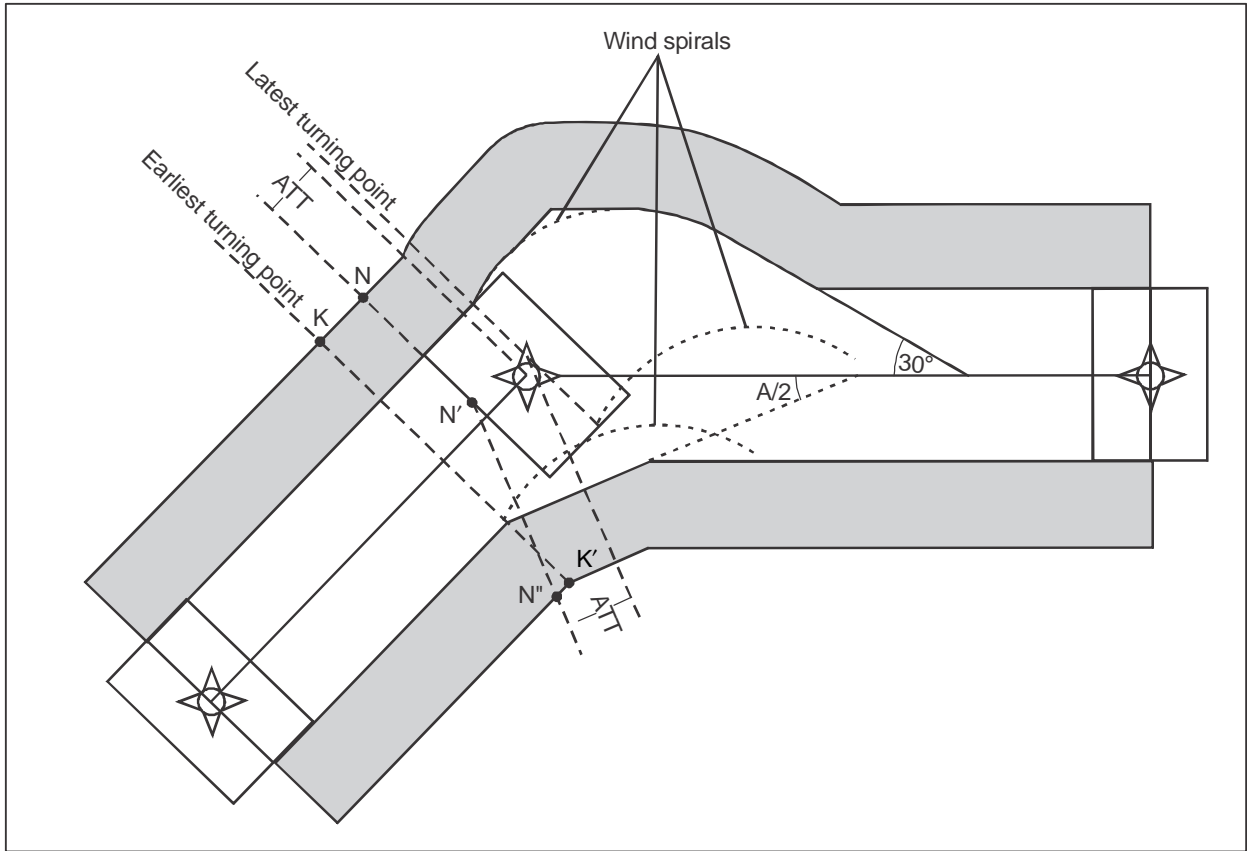

Figure III-2-2-5. NN'N'' Line — Fly-by turn with turn angle $\leq 90^\circ$

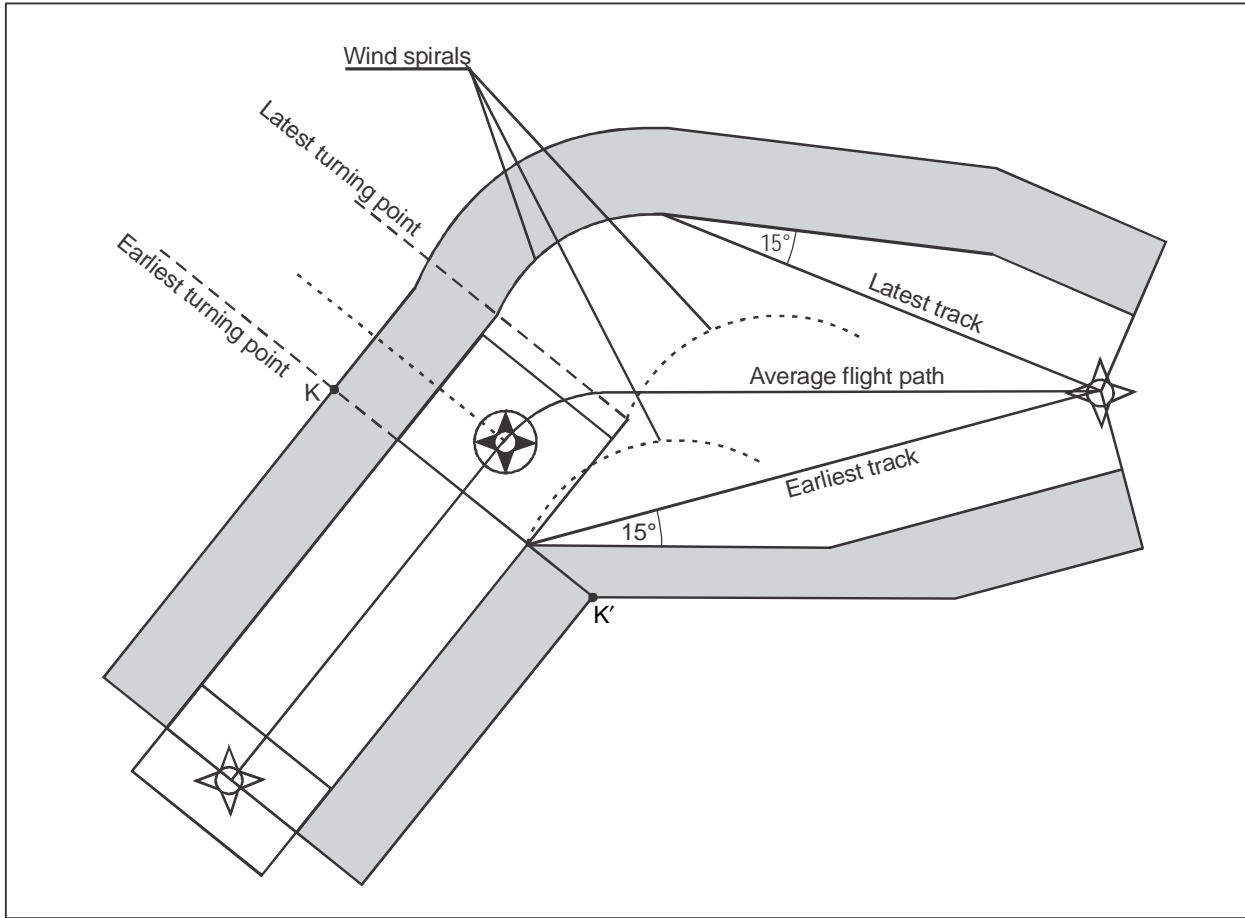

Figure III-2-2-6. Flyover turn, followed by a DF leg — small turn angle

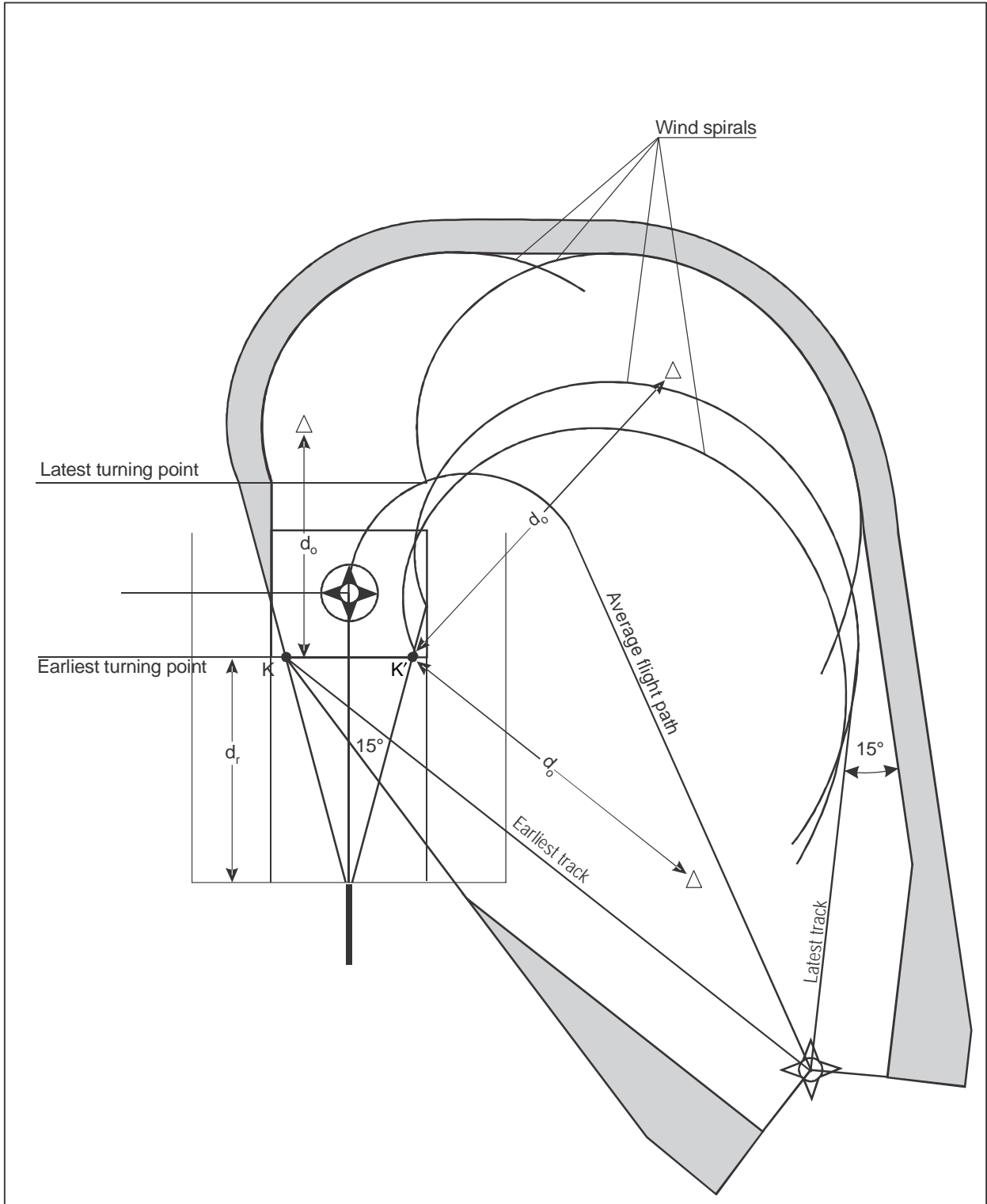

Figure III-2-2-7. Flyover turn, followed by a DF leg — large turn angle

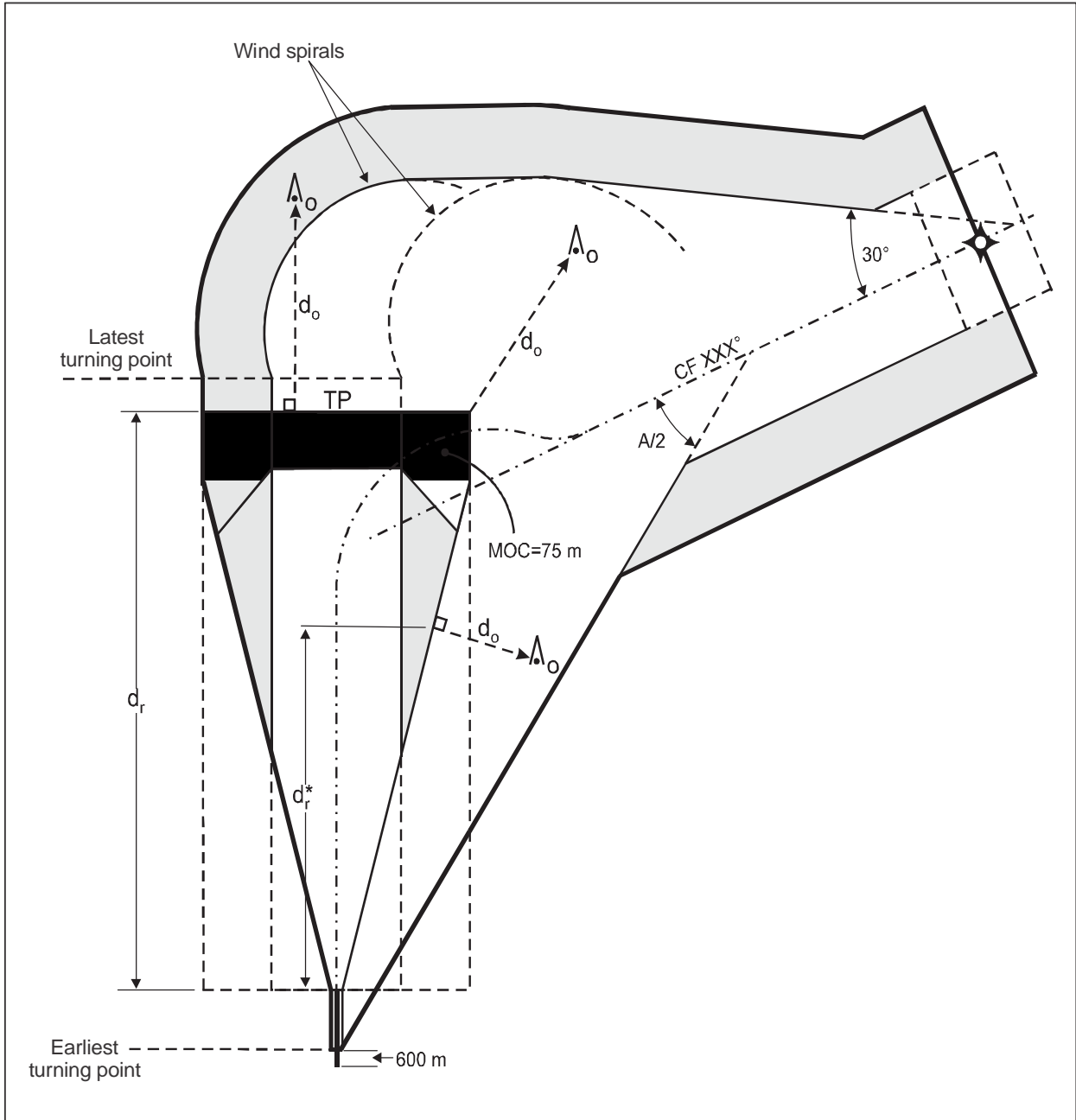

Figure III-2-2-8. Turning altitude/height, followed by a CF leg

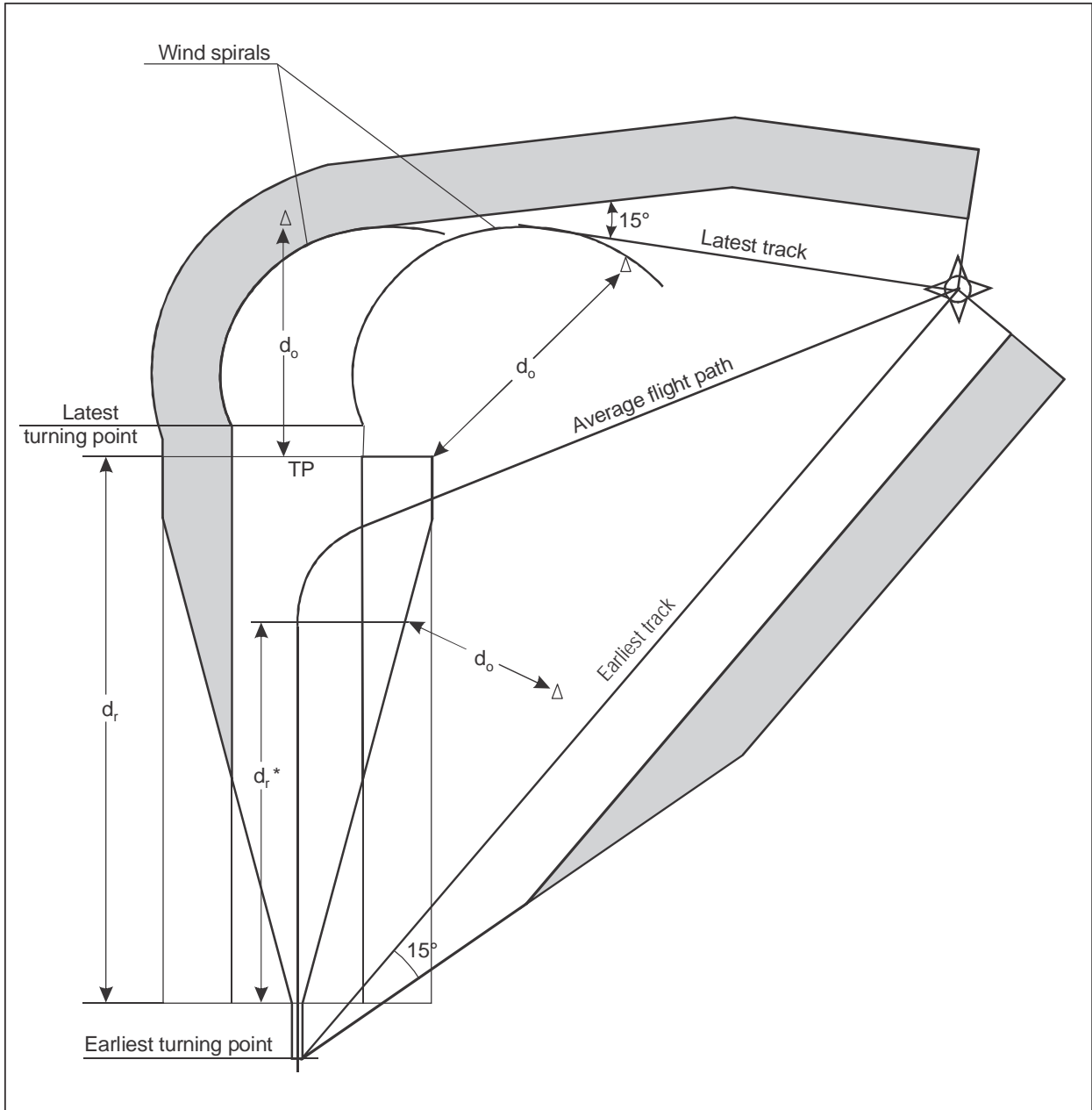

Figure III-2-2-9. Turning altitude/height, followed by a DF leg

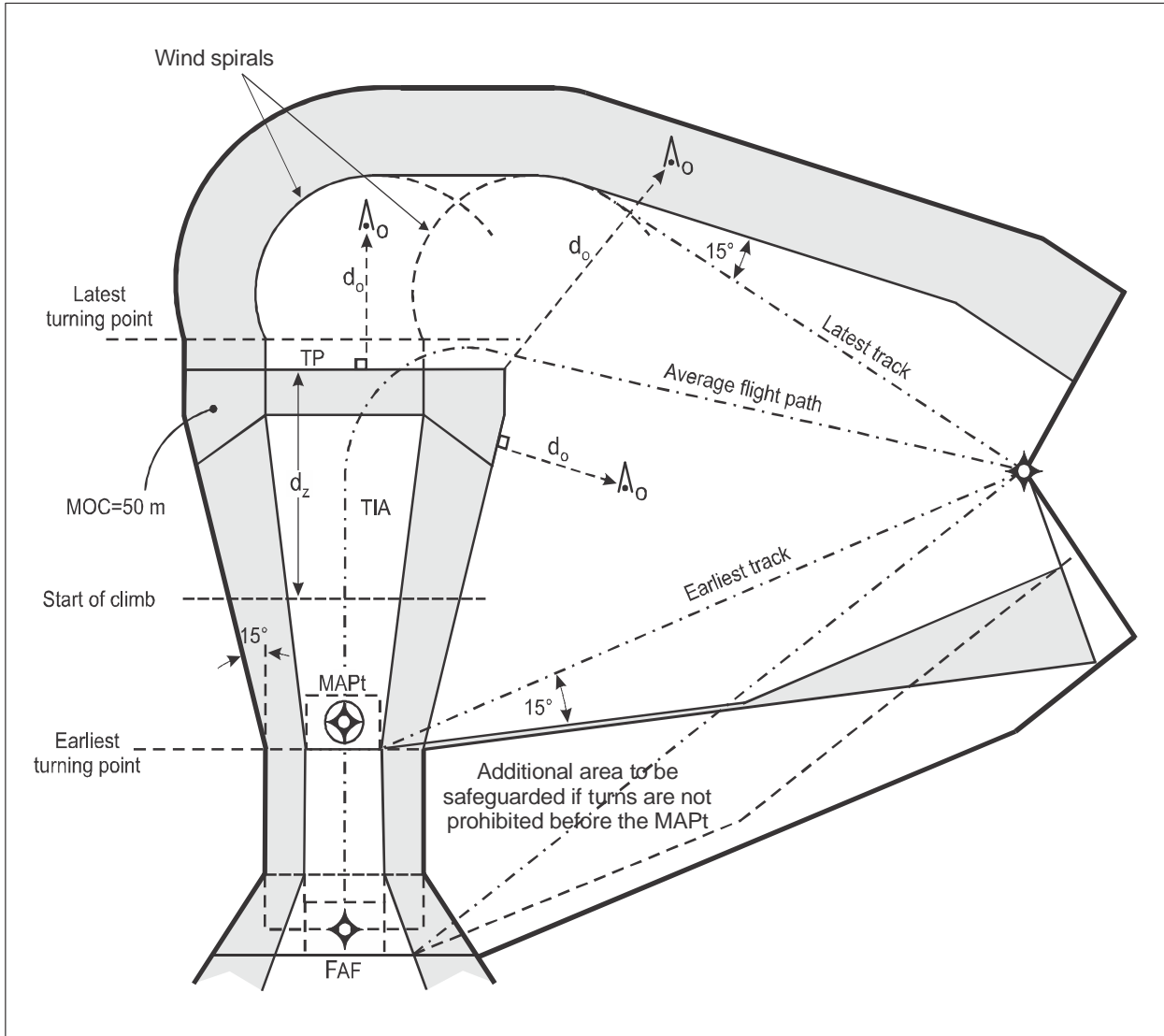

Figure III-2-2-10. Missed approach turning altitude/height, followed by a DF leg

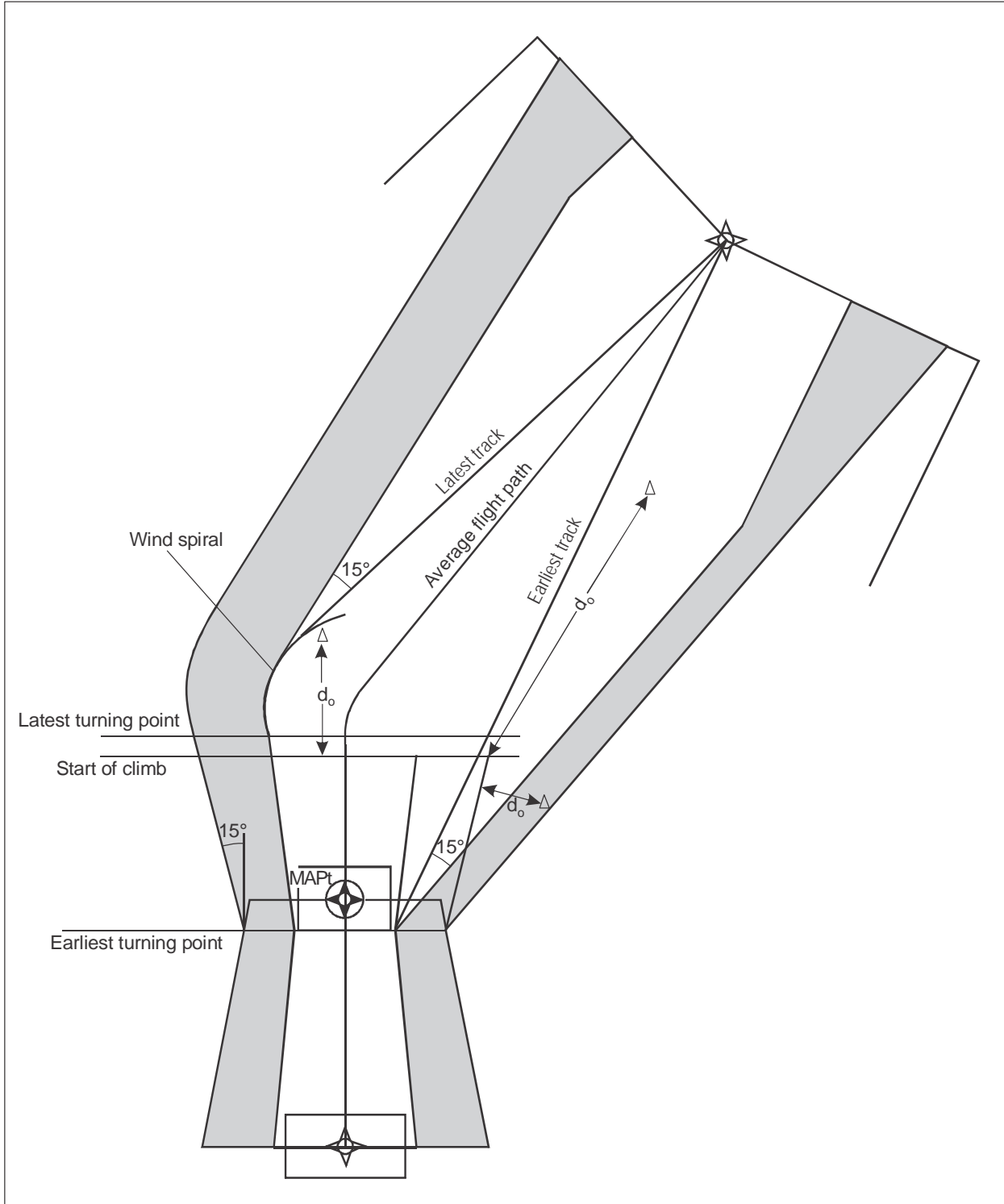

Figure III-2-2-11. Missed approach turn at the MAPt followed by a DF leg

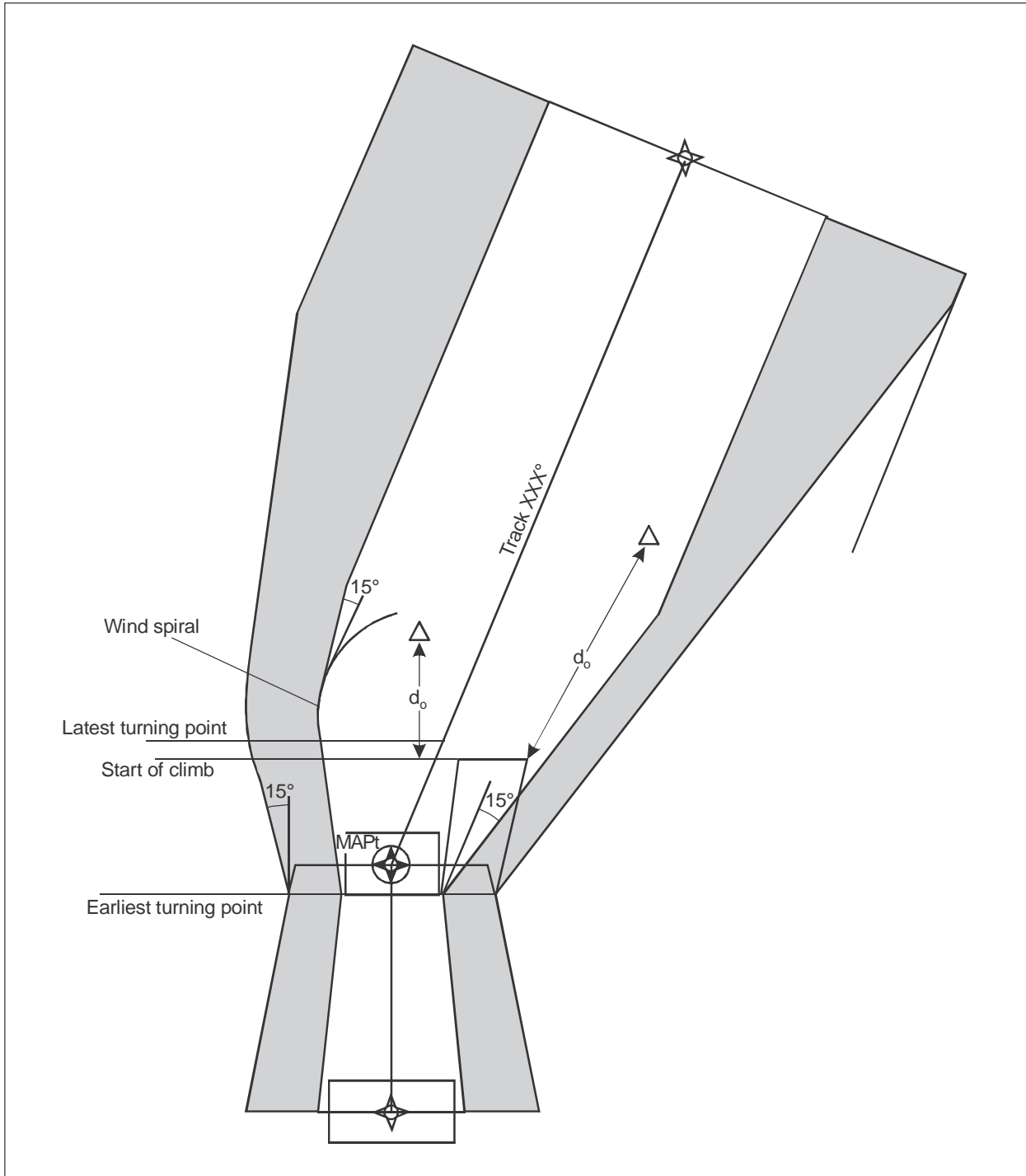

Figure III-2-2-12. Missed approach turn at the MAPt followed by a TF or CF leg

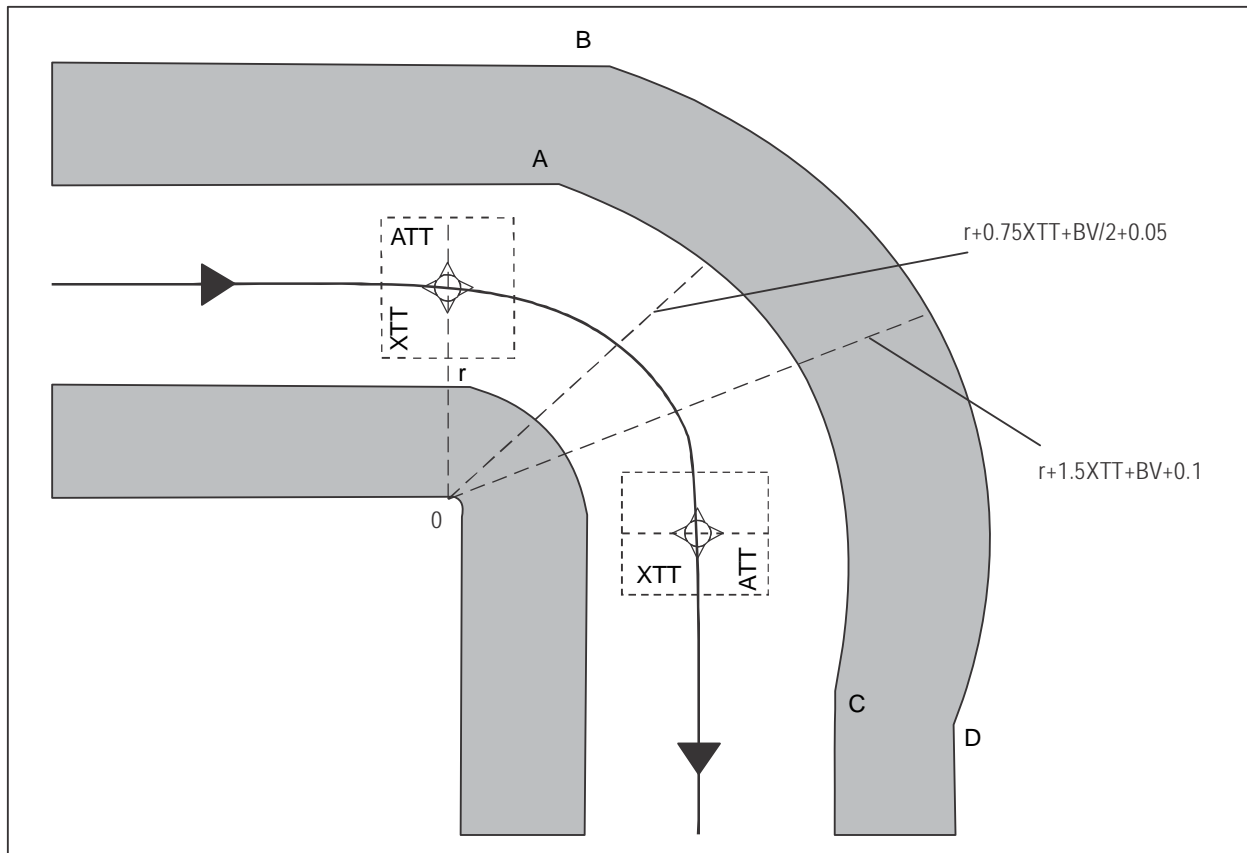

Figure III-2-2-13. RF turn protection

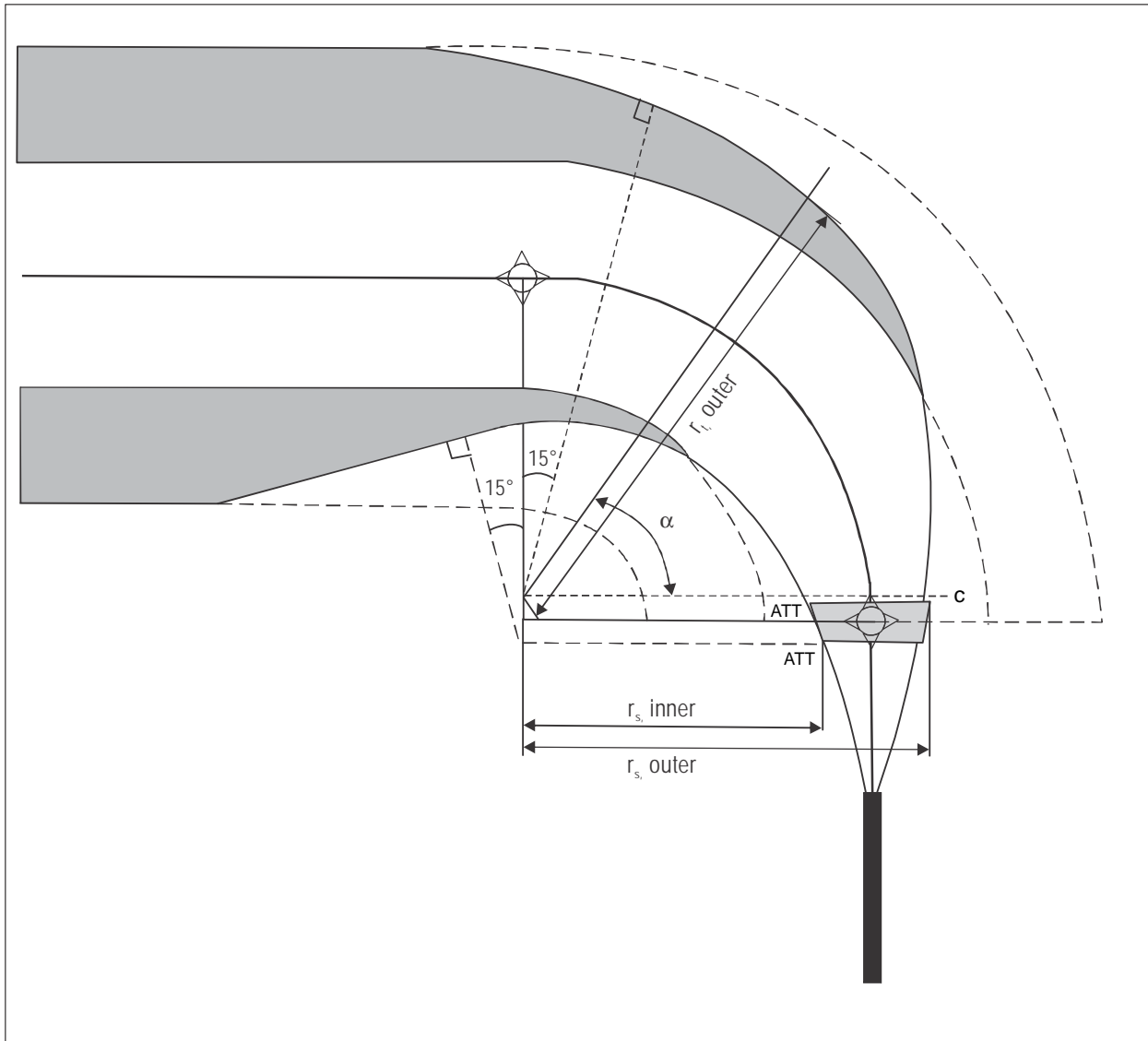

Figure III-2-2-14. Splay in RF turn

Chapter 3

RNAV T- OR Y-BAR PROCEDURE CONSTRUCTION

3.1 GENERAL CONCEPT

3.1.1 *Introduction.* An RNAV non-precision approach procedure or APV incorporating a T- or Y-bar arrangement is based on a runway aligned final segment preceded by an intermediate segment and up to three initial segments arranged either side of and along the final approach track to form a T or a Y (see Figure III-2-3-1 and Figure III-2-3-2).

3.1.2 *Capture region.* A T- or Y-bar arrangement permits direct entry to the procedure from any direction, provided entry is made from within the capture region associated with an IAF. A capture region is defined in terms of an included angle at the IAF (see Figure III-2-3-1 and Figure III-2-3-2).

3.1.3 The lateral initial segments are based on course differences of 70° to 90° from the intermediate segment track. This arrangement ensures that entry from within a capture region requires a change of course at the IAF not greater than 110°.

3.1.4 The central initial segment may commence at the IF.

3.1.5 Where one or both offset IAFs are not provided, a direct entry will not be available from all directions. In such cases a holding pattern may be provided at the IAF to enable entry to the procedure via a procedure turn.

3.1.6 Terminal Arrival Altitudes (TAAs) may be provided to facilitate descent and entry to the procedure. (See Chapter 4.)

3.1.7 The IAF, IF and FAF are defined by fly-by waypoints. The missed approach segment starts with a flyover waypoint (MAPt) and ends at a missed approach holding fix (MAHF). For turning missed approaches a missed approach turning fix (MATF) may also be established to define the turn point.

3.1.8 Area widths are determined in accordance with the tolerances applicable to the navigation system associated with the procedure.

3.2 INITIAL APPROACH SEGMENT

3.2.1 *Alignment.* Offset IAFs are located such that a course change of 70° to 90° is required at the IF. The capture region for tracks inbound to the offset IAF extends 180° about the IAFs, providing a direct entry when the course change at the IF is 70° or more. The central IAF is normally aligned with the intermediate segment. Its capture region is 70° to 90° either side of the initial segment track, the angle being identical to the course change at the IF for the corresponding offset IAF. (See Figure III-2-3-1 and Figure III-2-3-2). For turns greater than 110° at the IAFs, Sector 1 or 2 entries should be used (see Figure III-2-3-3).

3.2.2 *Length.* The initial approach segments have no maximum length. The optimum length is 9.3 km (5.0 NM) (Cat H, 5.5 km (3.0 NM)). The minimum segment length shall be not less than the distance required by the highest initial approach speed (see Tables III-2-3-1 and III-2-3-2) for the fastest category of aircraft for which the approach is

designed. This distance is the sum of the minimum stabilization distances required at the IAF and IF and can be derived from Table III-2-1-3 or Table III-2-1-9.

Note.— The optimum length of 9.3 km (5.0 NM) ensures that the minimum segment length for aircraft IAS up to 390° km/h (210 kt) below 3 050 m (10 000 ft) will be accommodated.

3.2.3 *Descent gradient.* The optimum descent gradient is 4% (Cat H, 6.5%). Where a higher gradient is necessary to avoid obstacles, the maximum permissible is 8% (Cat H, 10%). Descent gradient is based on the shortest possible track distance (TRD) for the fastest category of aircraft, and not the segment length.

3.2.4 *Calculation of track distance (TRD).* The TRD between two fly-by waypoints is defined as the segment length reduced by the stabilization distance at both turns ($r \tan \theta/2$) and increased by the distance flown in the turn from abeam the waypoint to the tangent point ($2\pi r \times 0.5\theta/360$).

$$\text{TRD} = \text{segment length} - r(\tan \theta_1/2 + \tan \theta_2/2) + \pi r (\theta_1 + \theta_2)/360$$

where:

- θ_1 = turn angle (degrees) at the beginning of the segment
- θ_2 = turn angle (degrees) at the end of the segment
- r = turn radius at 25° bank angle

Example for a first 110° turn and a second 70° turn:

$$\text{TRD} = \text{segment length} - 0.56r$$

3.2.5 *Shortest initial approach segments.* For the offset initial approach segments, the shortest possible track distance will occur when a 110° turn is made at the IAF and a 70° turn is made at the IF for a Y-bar procedure and when a 90° turn is made at either the IAF or the IF for a T-bar procedure. For the central initial approach segment, the shortest possible track distance will occur when a 90° turn is made at the IAF.

3.2.6 *Procedure entry altitude.* The procedure is entered at the 46 km (25 NM) minimum sector altitude or terminal arrival altitude. Where the initial approach waypoint forms part of an air route, the procedure should be entered at the minimum en-route altitude applicable to the route segment.

3.2.7 *Reversal procedures.* When all three initial segment legs are implemented there is no need for reversal procedures. Should one of the legs not be implemented, a racetrack pattern may be established at either or both of the other IAFs. In the event that the central IAF leg is one of the remaining legs, its capture region is adjusted to accommodate normal sector entries into a reversal procedure (see Figure III-2-3-3).

3.2.8 *Holding.* A holding pattern may be provided at any IAF and should be aligned with the initial segment track.

3.3 INTERMEDIATE APPROACH SEGMENT

3.3.1 *Alignment.* The intermediate approach segment should be aligned with the final approach segment whenever possible. If a turn at the FAF is necessary it shall not exceed 30°.

3.3.2 *Length.* The intermediate segment consists of two components — a turning component abeam the IF followed by a straight component immediately before the FAF. The length of the turning component is the minimum stabilization distance for the turn angle at the IF and can be determined from the tables in Chapter 1. The length of the straight component is variable but shall not be less than 3.7 km (2.0 NM) allowing the aircraft to be stabilized prior to the FAF.

3.3.3 *Descent gradient.* The general criteria at Part I, Section 4, Chapter 4, 4.3.3, “Procedure altitude/height and descent gradient” apply. Where a descent is required, the descent gradient shall be calculated for the shortest possible track distance for the fastest category of aircraft, and not the segment length. (For calculation of TRD see 3.2.4).

3.3.4 Where a track change occurs at the FAF, the reduction in track distance may be ignored as the difference is negligible. (Maximum angle of turn is 30°.)

3.4 FINAL APPROACH SEGMENT

3.4.1 *Alignment.* The optimum alignment of the final approach segment is the runway centre line. If this is not possible, the general criteria apply.

3.4.2 *Length.* The optimum length of the final approach segment is 9.3 km (5.0 NM) (Cat H, 3.7 km (2.0 NM)).

3.4.3 *Descent gradient.* The general criteria in Part I, Section 4, Chapter 5, 5.3, “Descent gradient” apply.

3.5 MISSED APPROACH SEGMENT

3.5.1 *Missed approach point.* The missed approach point shall be defined by a fly-over waypoint.

3.5.2 *Location of MAPt.* For a runway-aligned approach, the missed approach point shall be located at or before the threshold. Where the final segment is not aligned with the runway centre line, the optimum location is the intersection of the final approach track and the extended runway centre line. (See Figure III-3-3-1.) In order to provide obstacle clearance in the missed approach area the MAPt may be positioned closer to the FAF but no further than necessary and not beyond the point where the OCH intersects the path of a nominal 5.2 per cent/3° descent gradient to the runway.

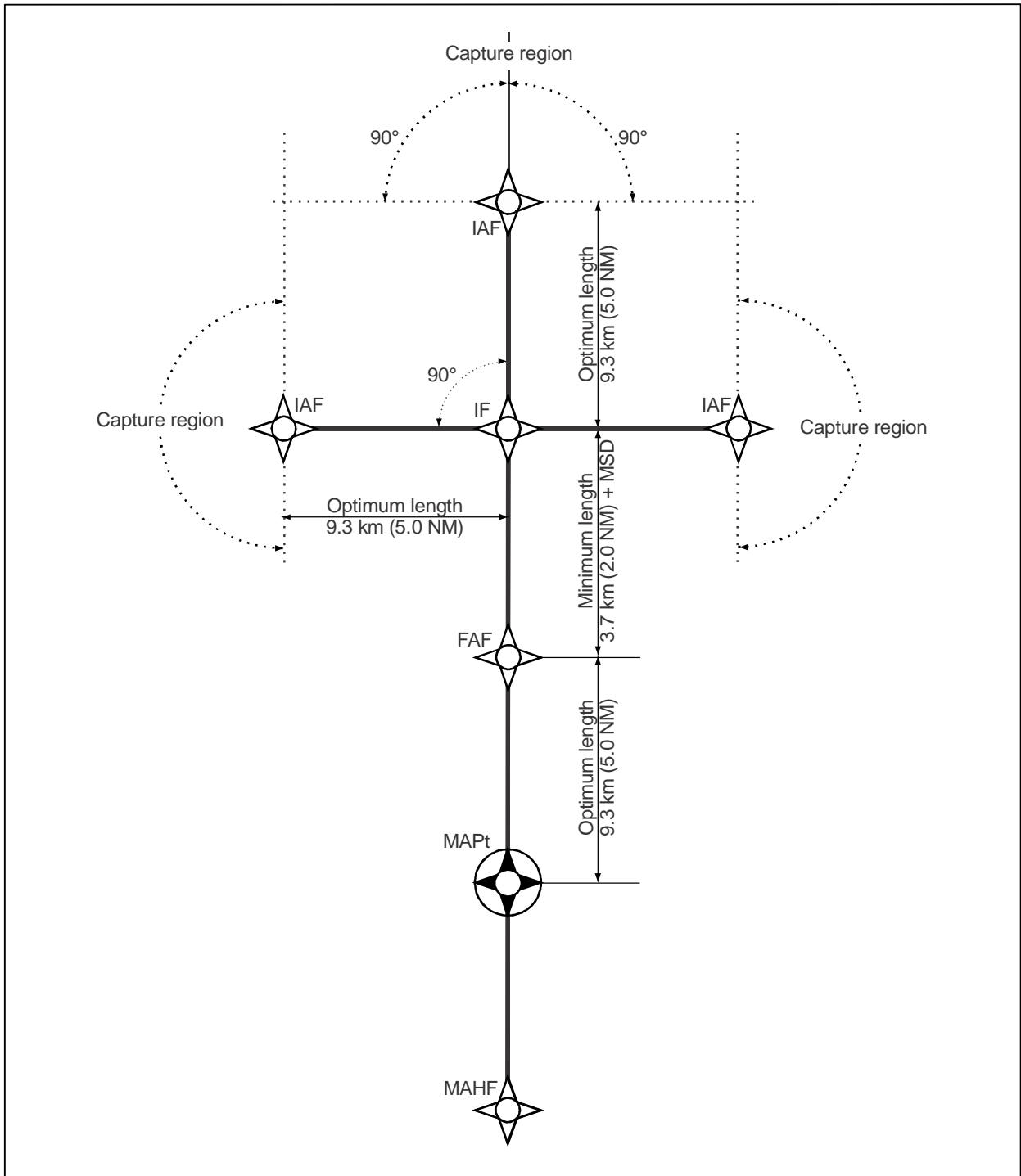

Figure III-2-3-1. T-bar general arrangement

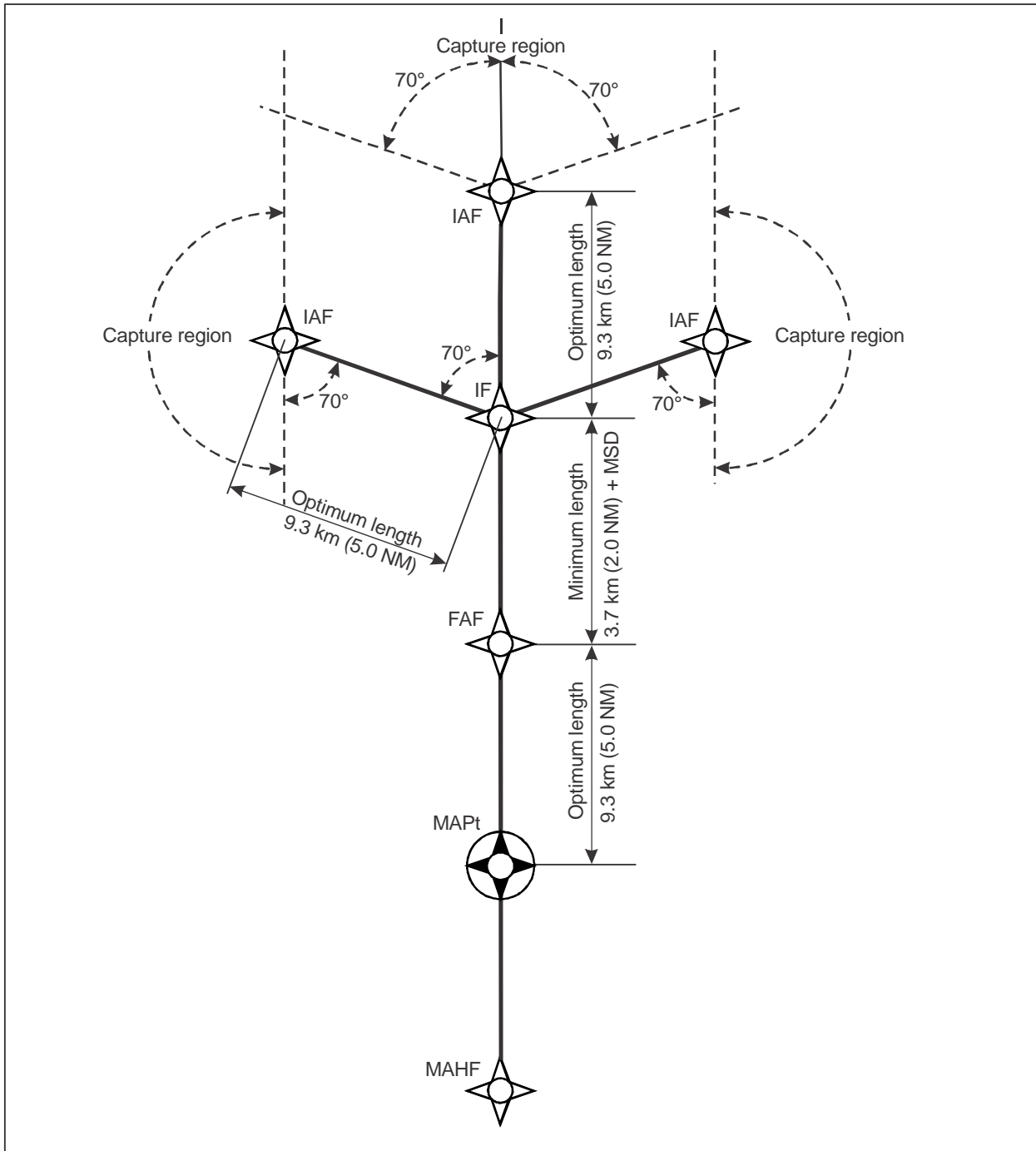

Figure III-2-3-2. Y-bar general arrangement

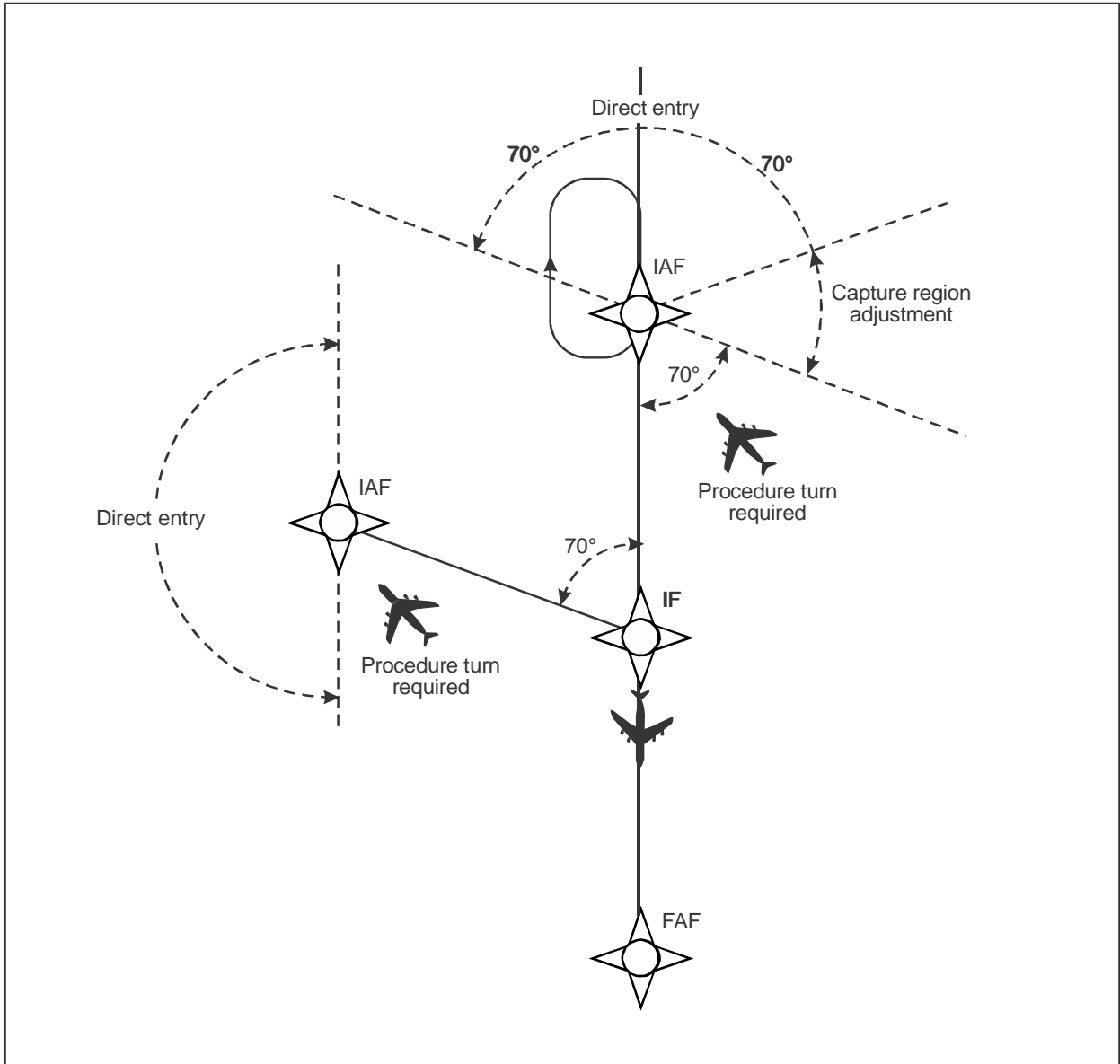

Figure III-2-3-3. Reversal procedures where offset initial not provided

Chapter 4

TERMINAL ARRIVAL ALTITUDE (TAA)

4.1 GENERAL

4.1.1 Terminal arrival altitudes (TAAs) should be established for any RNAV procedure based upon the T or Y arrangement described in Chapter 3.

4.1.2 If appropriate, minimum sector altitude (MSA) may be established instead of TAAs for an RNAV instrument approach procedure.

4.1.3 The TAA reference points are the initial approach and/or intermediate fixes.

4.1.4 Each TAA shall be calculated by taking the highest elevation in the area concerned, adding a clearance of at least 300 m (1 000 ft) and rounding the resulting value up to the next higher 50-m or 100-ft increment, as appropriate. If the difference between adjacent TAAs is insignificant (i.e. in the order of 100 m or 300 ft as appropriate) a minimum altitude applicable to all TAAs may be established.

4.1.5 A minimum altitude shall apply within a radius of 46 km (25 NM) of the RNAV waypoints on which the instrument approach is based. The minimum obstacle clearance when flying over mountainous areas should be increased by as much as 300 m (1 000 ft).

4.2 CONSTRUCTION

4.2.1 The standard arrangement consists of three TAAs: straight-in, right and left base.

4.2.2 TAA lateral boundaries are defined by the extension of the left and right base initial segments. The outer area boundaries are determined by arcs of 46 km (25 NM) radius centred on each of the three IAFs or on the two base area IAFs and the IF where the central initial segment is not provided. (See Figure III-2-4-1 and Figure III-2-4-2).

4.3 BUFFER AREA

Each TAA is surrounded by a buffer area of 9 km (5 NM). If obstacles within the buffer area are higher than the highest obstacle within the TAA area, then the minimum altitude shall be calculated by taking the highest elevation in the buffer area, adding a clearance of at least 300 m (1 000 ft) and rounding the resulting value up to the nearest 50 m or 100 ft.

4.4 TAA STEPDOWN ARCS AND SUBSECTORS

4.4.1 To accommodate terrain diversity, operational constraints or excessive descent gradients, an additional circular boundary or “stepdown arc” may be defined dividing a terminal arrival altitude (TAA) into two areas with the lower altitude in the inner area. Additionally, the straight-in TAA may be divided into radial subsectors (see Figures III-2-4-3 to III-2-4-5).

4.4.2 Stepdown arcs are limited to one per TAA. A stepdown arc should be no closer than 19 km (10 NM) from the fix upon which the arc is centred and a minimum of 19 km (10 NM) from the 25 NM TAA boundary, in order to avoid too small a subsector.

4.4.3 The straight-in TAA area may also be divided radially into subsectors. The minimum size of any straight-in TAA subsector that also contains a stepdown arc shall be no less than 45 arc degrees. The minimum size of any straight-in TAA subsector that does not contain a stepdown arc shall not be less than 30 arc degrees.

4.4.4 Left and right TAA base areas may only have stepdown arcs, and shall not be further divided into radial subsectors.

4.4.5 The width of the buffer area between adjacent stepdown arcs and adjacent subsectors is 9 km (5 NM).

4.5 PROMULGATION

4.5.1 TAAs shall be depicted on the plan view of approach charts by the use of “icons” which identify the TAA reference point (IAF or IF), the radius from the reference point, and the bearings of the TAA boundaries. The icon for each TAA area will be located and oriented on the plan view with respect to the direction of arrival to the approach procedure, and will show all TAA minimum altitudes and stepdown arcs for that area.

4.5.2 The IAF for each TAA is identified by the waypoint name to help the pilot orient the icon to the approach procedure. The IAF name and the distance of the TAA area boundary from the IAF are included on the outside arc of the TAA area icon. TAA icons also identify where necessary the location of the intermediate fix by the letters “IF” and not the IF waypoint identifier to avoid misidentification of the TAA reference point and to assist in situational awareness. (See Figures III-2-4-3, III-2-4-4, III-2-4-5.)

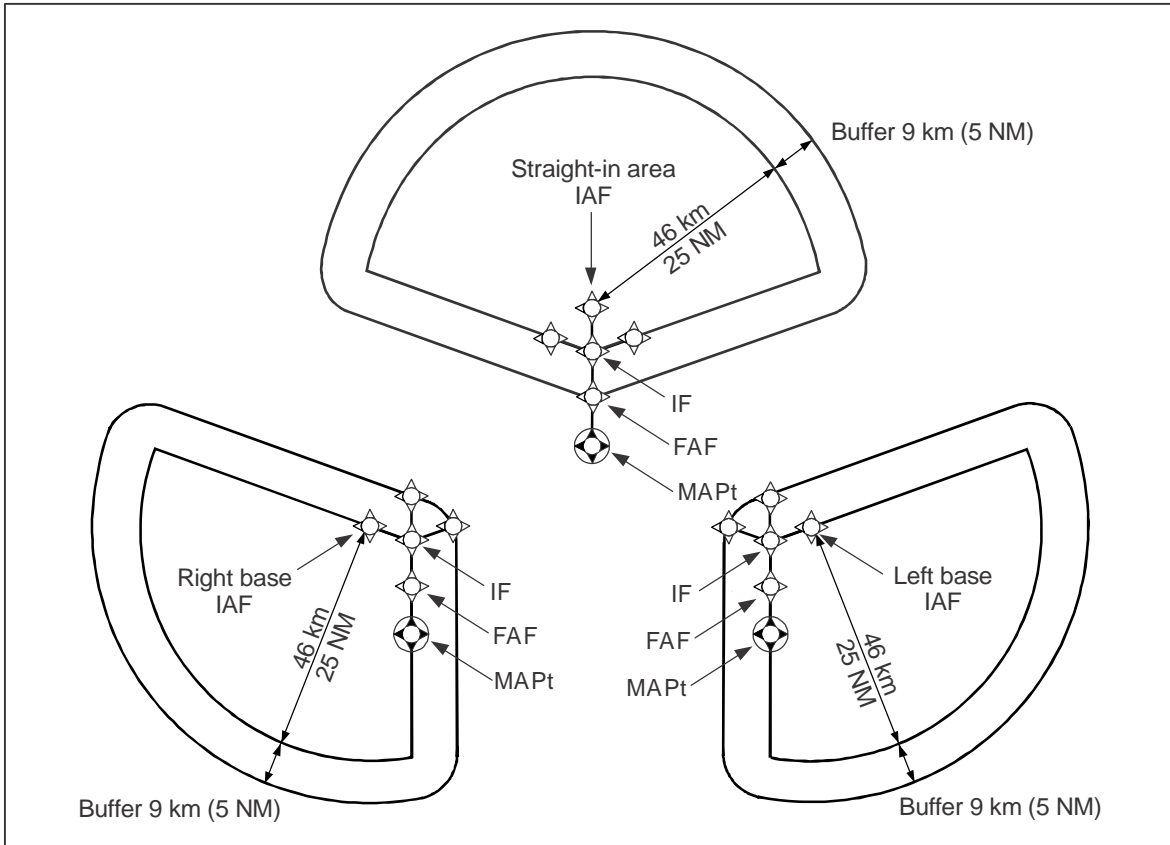

Figure III-2-4-1. TAA Y-bar arrangement

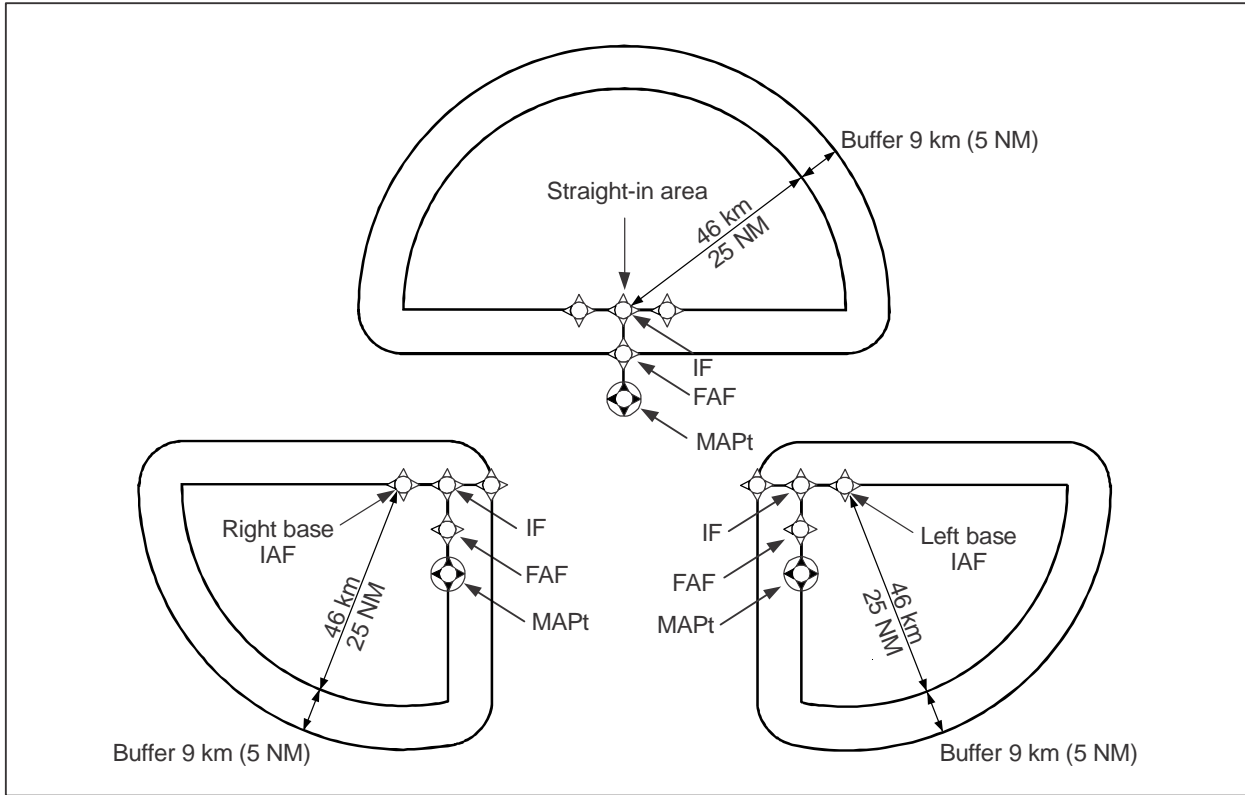

Figure III-2-4-2. TAA T-bar arrangement

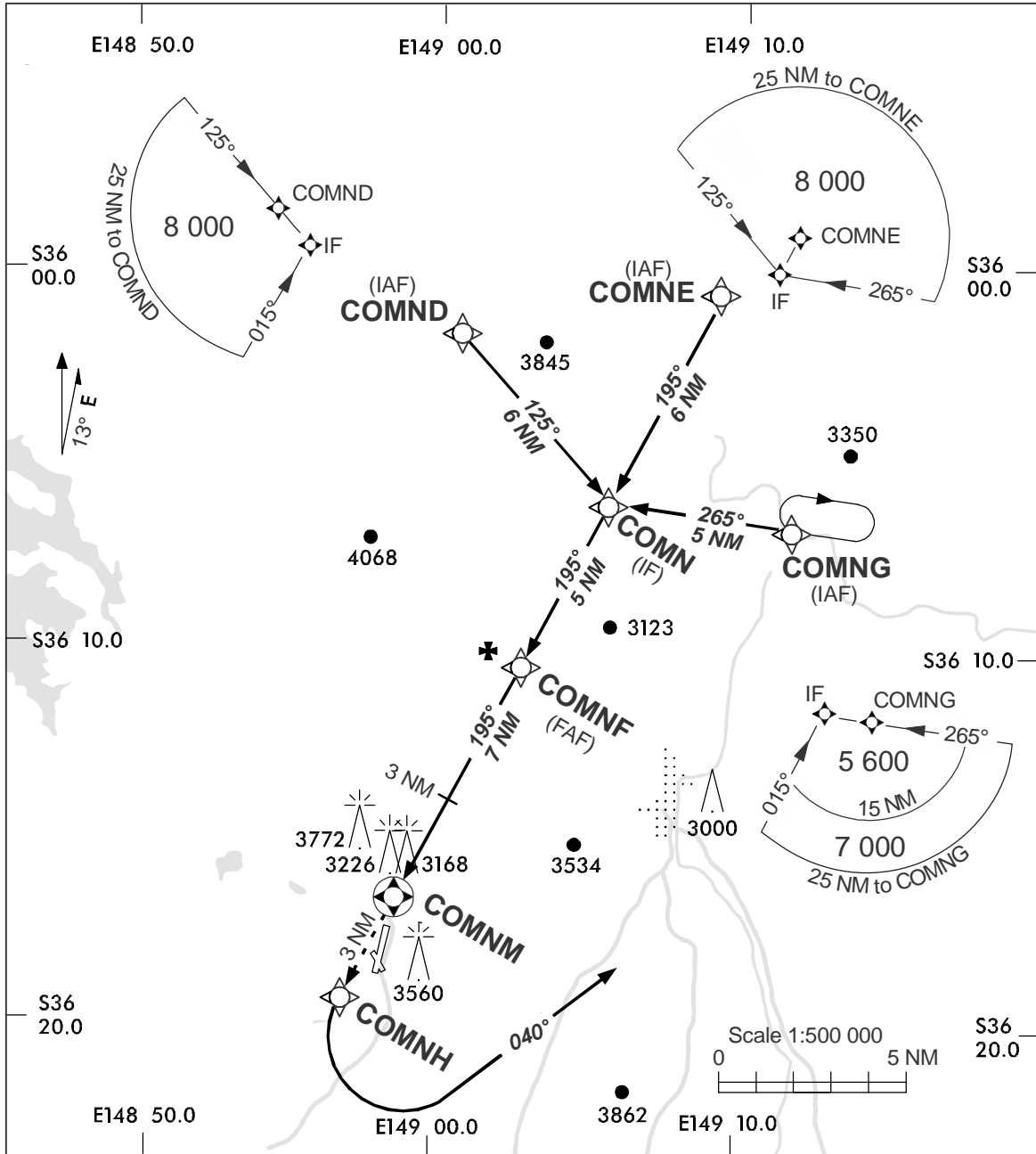

Figure III-2-4-3. TAA Y-bar icon arrangement

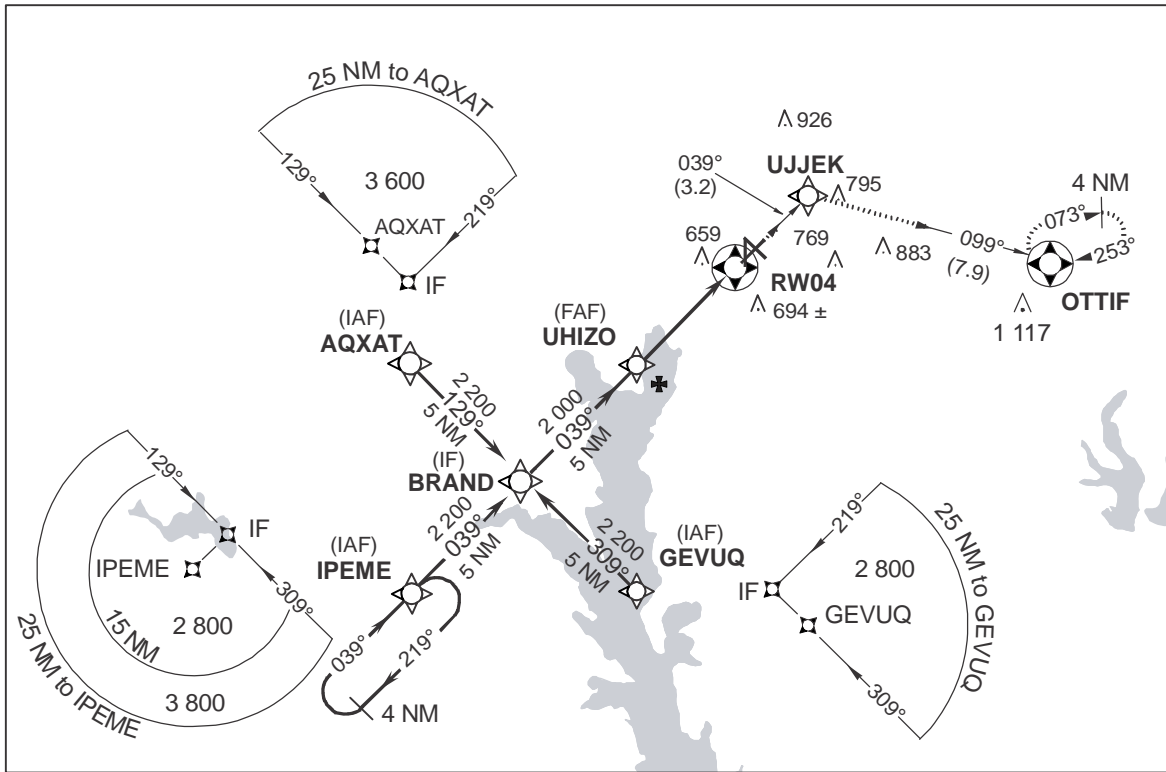

Figure III-2-4-4. TAA T-bar icon arrangement

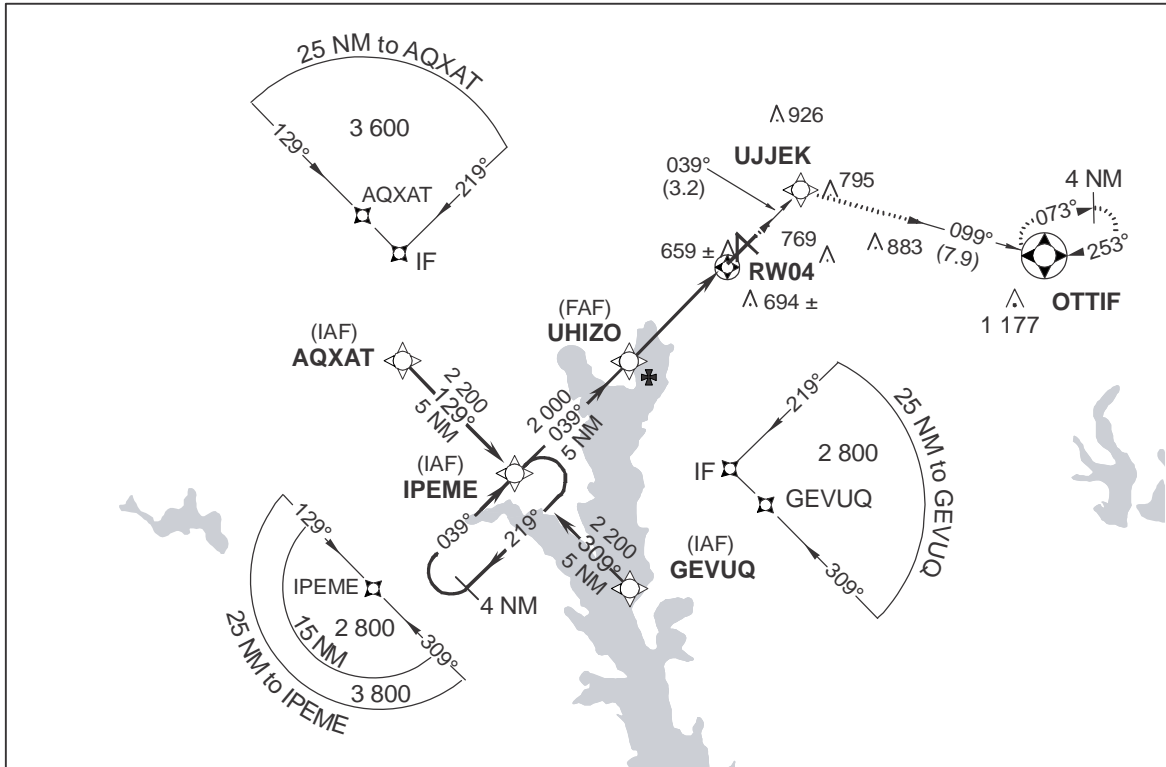

Figure III-2-4-5. TAA T-bar icon arrangement without centre initial

Chapter 5

NAVIGATION DATABASE CODING

5.1 GENERAL

5.1.1 The purpose of this chapter is to provide guidance to procedure designers concerning elements in procedure design that will facilitate the coding of procedures into navigation databases.

5.1.2 All navigation data used by an RNAV system that is certified for terminal operations are held in a navigation database. These databases are derived from data that is coded in accordance with the aviation industry standard: ARINC 424 'Navigation System Database Specification', or an equivalent industry standard.

5.1.3 In order to achieve the translation of the textual description of a procedure, and the routes depicted on the charts, into a code suitable for navigation systems, the aviation industry has developed the 'Path and Termination' concept for terminal procedures.

5.1.3.1 The path terminators as defined in PANS-OPS, are used to define specific ground tracks on the assumption that aircraft approved to fly RNAV procedures have the capability to maintain consistent tracks based upon the use of appropriate ARINC 424 path terminators, or their equivalent.

5.1.3.2 Path terminators should be used to define each leg of an RNAV route from takeoff until the en-route segment is joined and from the point where the aircraft leaves the en-route segment until the end of the RNAV procedure(s). Path terminators are not used to construct en-route segments or other routes outside terminal airspace.

5.1.4 Many aircraft are equipped with RNAV systems that are only capable of using a sub-set of the available ARINC 424 path terminators. It is important that the procedure designer takes this into account and correlates the design with the basis for operational approval and certification, which should state the minimum functionality required of the RNAV system, including which path terminators can support the design. The material in this chapter and its appendix have been developed to accommodate the majority of aircraft that are expected to be approved to fly RNAV SIDs, STARs and approaches. In certain cases, alternative coding (such as path terminators, speed and altitude restrictions) may be used to enable specific RNAV systems to better follow the intended track – such actions should be approved by the associated State Regulator and are within the purview of the data coder and the avionics manufacturer. In addition, fixed radius turns, which are only applicable to RNP-capable systems, are also addressed in this chapter.

5.2 PATH TERMINATOR TYPES

5.2.1 The definition for path and terminator ("Path terminator") is provided in Part I, Section 1, Chapter 1. Currently there are 23 different path terminators defined in ARINC 424. However, only eleven of these path terminators are acceptable for RNAV procedure design use and an additional path terminator, IF, is used when coding the procedure in the database. A smaller sub-set of four path terminators should be used for RNP applications: IF, TF, RF, and HM. Descriptions of all the RNAV procedure design codes are provided below:

Initial fix (IF)

The coding of RNAV procedures starts at an IF. An IF does not define a desired track in and of itself, but is used in conjunction with another leg type (e.g. TF) in order to define the desired path. It is not used in the design process and need not be published with the procedure description.

Track to a fix (TF)

The primary straight route segment for RNAV is a TF route. The TF route is defined by a geodesic path between two waypoints. The first of the two waypoints is either the termination waypoint of the previous segment or an initial fix (IF). The intermediate and final approach segments should always be TF routes. In cases where an FMS requires a CF for the final approach segment, the database coder may use CF in lieu of TF.

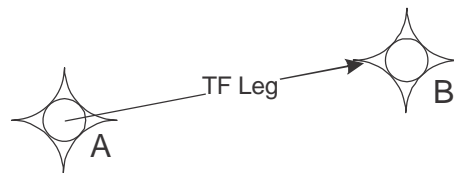
**Direct to a fix (DF)**

A DF is used to define a route segment from an unspecified position, on the aircraft's present track, to a specified fix/waypoint. The DF path terminator does not provide a predictable, repeatable flight path and is highly variable in its application. When used after an FA, VA or CA the DF is effective in dispersing the tracks over the widest area and the CA/DF combination can be used to spread environmental impact on initial departures. The DF also ensures that the shortest track distance is flown from the turning point (fly-over waypoint) or from a turn altitude to the next waypoint. The use of DF is further constrained by a number of specific rules detailed in 5.3.

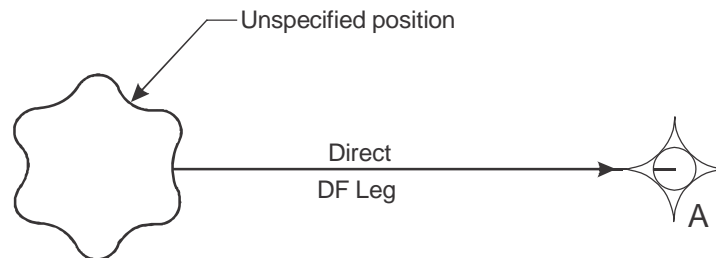
**Course to an altitude (CA)**

A CA is used to define the course of an outbound route segment that terminates at an altitude with an unspecified position. The CA is used in preference to an FA as the initial path terminator in a SID, in order to guard against the effects of IRS drift.

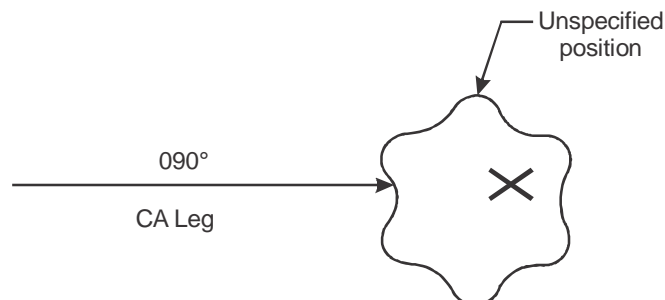

Course to a fix (CF)

A CF is defined as a course that terminates at a fix/waypoint followed by a specific route segment. A CF was originally the only path terminator permitted to define the final segment of an approach and is currently used for this purpose by many RNAV systems. Normal use of the CF is after an FA or CA in a departure or missed approach where it is effective in constraining the track dispersion. The CA/CF combination can be effective in reducing environmental impact on initial departures. The use of CF is further constrained by a number of specific rules detailed in 5.3.

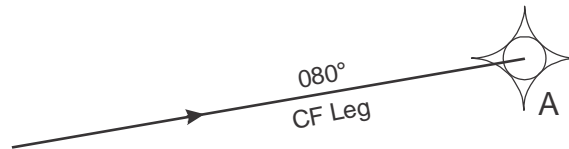

Course from a fix to an altitude (FA)

An FA is used to define a route segment that begins at a fix/waypoint and terminates at a point where the aircraft altitude is at, or above, a specified altitude. No position is specified for the altitude point. The FA track does not provide a predictable, repeatable flight path, due to the unknown termination point, but is a useful path terminator in missed approach procedures.

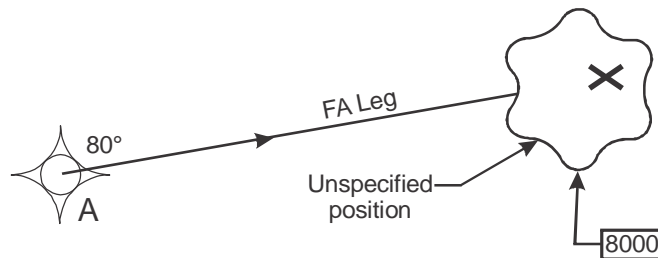

Course from a fix to a manual termination (FM)

An FM is used when a route segment is terminated for radar vectors. It provides similar functionality to the VM. The aircraft continues on the prescribed heading until intervention by the pilot.

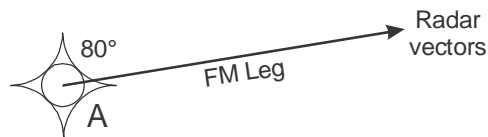

Holding/Racetrack to a manual termination (HM)

An HM is used to define a holding pattern path that is manually terminated by the flight crew.

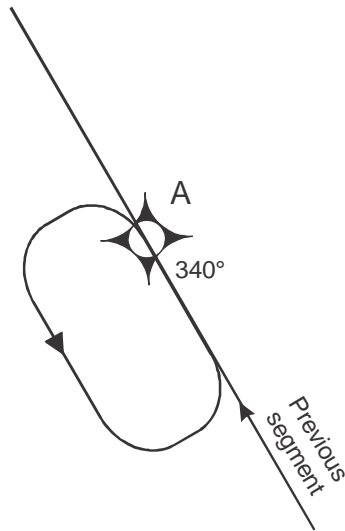
**Constant radius arc to a fix (RF)**

The RF segment is a circular path about a defined turn centre that terminates at a waypoint. The beginning of the arc segment is defined by the terminating waypoint of the previous segment. The waypoint at the end of the arc segment, the turn direction of the segment and the turn centre are provided by the navigation database. The radius is computed by the RNAV system as the distance from the turn centre to the termination waypoint. A single arc may be defined for any turn between 2° and 300°. RF functionality is generally only available in systems designed to meet RNP-RNAV requirements such as those laid down in EUROCAE ED76()/RTCA DO 236().

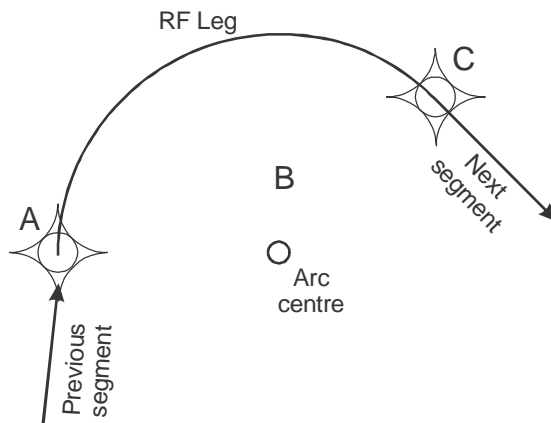

Heading to an altitude (VA)

A VA is often used on departures where a heading rather than a track has been specified for climb-out. The segment terminates at a specified altitude without a terminating position. It is only used in RNAV design on parallel departures where initial heading legs are required.

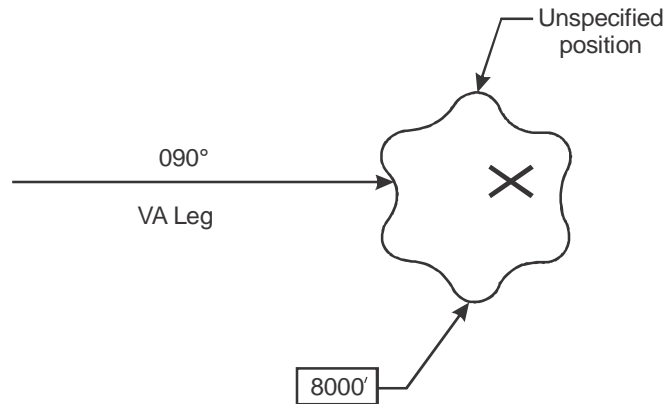

Heading to an intercept (VI)

A VI segment is coded wherever a heading is assigned to an aircraft until it intercepts the next leg segment. The aircraft continues on the prescribed heading until the next leg is intercepted.

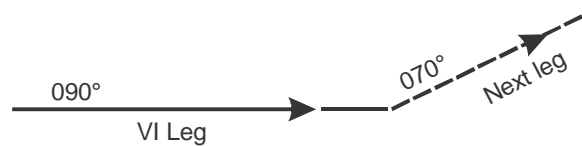

Heading to a manual termination (VM)

A VM segment may be coded wherever radar vectoring is provided at the end of a procedure. It provides similar functionality to the FM. The aircraft continues on the prescribed heading until intervention by the pilot.

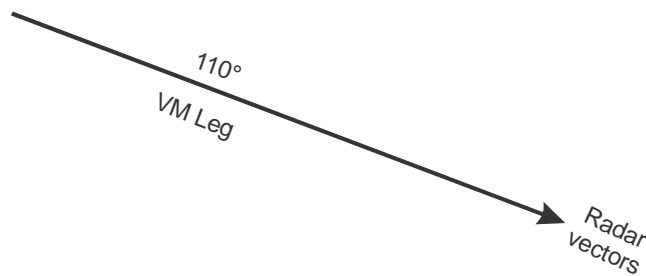

5.3 PROCEDURE DESIGN APPLICATION

5.3.1 *Path terminators.* The application of the path terminator concept is bound by a comprehensive set of rules that have been developed and updated by industry since 1980 and are published as an ARINC specification (ARINC 424, Navigation System Database). As the procedure designer is concerned with a sub-set of the path terminators, the main rules pertinent to these path terminators have been provided in the appendix to this chapter. It is imperative that the procedure designer adheres strictly to these rules if the procedure is to be correctly coded in the airborne navigation database.

5.3.2 *Other design considerations.* The procedure designer should take the following factors into consideration to ensure unambiguous translation of the design into the navigation data base.

- a) dual-conditional transitions, such as “climb to XXXX feet by waypoint NNNNN”, or “at waypoint YYZZZ but not below XXXX feet, turn right direct to (waypoint)”, cannot be used;
 - b) altitude and speed restrictions shall only be applied at a waypoint; and
 - c) all details of any specific restrictions applied to a procedure shall be published.
-

Appendix to Chapter 5

PATH TERMINATOR CODING RULES

1. Rules and standards detailed in this attachment are based upon ARINC 424-15. Some functionality has been excluded, either because it is not yet implemented in the majority of aircraft systems or because it was developed for use on conventional procedures and is not applicable to RNAV procedures.

2. Table III-2-5-App-1 defines the path terminators that can support the initial and final legs of an RNAV procedure (SID, STAR, approach and missed approach).

Table III-2-5-App-1. Initial and final path terminators

<i>RNAV procedure</i>	<i>Initial leg</i>	<i>Final leg</i>
SID	CA, CF, VA, VI	CF, DF, FM, RF, TF, VM
STAR	IF	CF, DF, FM, HM, RF, TF, VM
Approach	IF	CF, TF, RF
Missed approach	CA, CF, DF, FA, HM, RF, VI, VM	CF, DF, FM, HM, RF, TF, VM

3. If a course to fix (CF) is used as the first leg of a sequence, the design shall be validated for inadvertent low altitude banking of an aircraft.

Note 1.— The ‘Final Leg’ for an approach is the final approach segment.

Note 2.— The only valid starting path terminators for the SID, from a procedure design perspective, are CA or CF. Although, according to ARINC 424, FA is allowed as an initial SID leg, it generates the same ground track as CA but is not appropriate for some operations with aircraft that rely solely on IRU inputs in the initial departure phases. In such cases an IRU with a degraded position can result in the aircraft making unexpected turns shortly after lift-off. In this context, CA generates the same ground track as FA. Furthermore, an FA path terminator on parallel departures can cause significant track deviations due to inertial drift prior to take-off. VA may be used for parallel departures where aircraft are required to follow a heading rather than a track after take-off. Database suppliers may also use VA in place of FA when coding equivalent SIDs from adjacent parallel runways in order to minimize duplicate coding (many databases in older RNAV systems have storage capacities of less than 200 kilobytes).

Note 3.— As one of the methods to alleviate the possibility of inadvertent low altitude banking, the use of a course to altitude (CA) leg type to an altitude of at least 122 m (400 ft) above the DER elevation may be considered before the course to fix (CF) leg type.

Note 4.— FM or VM may be used to terminate ‘Open STARS’ when radar vectoring is provided to final approach. The choice of track (FM) or heading (VM) depends upon ATC requirements.

Note 5.— RF may only be used for RNP procedures flown by aircraft equipped with systems that are compatible with ARINC 424-17, or later.

Table III-2-5-App-2. Path terminator sequences

		Next Leg											
		IF	CA	CF	DF	FA	FM	HM	RF	TF	VA	VI	VM
Current Leg	CA												
	CF				1								
	DF				1								
	FA												
	FM												
	HM												
	IF					2	2	2	3				
	RF												
	TF												
	VA												
	VI												
	VM												

4. Table III-2-5-App-2, “Path terminator sequences” defines the permitted leg sequences. A shaded space indicates that the “current leg/next leg” sequence is not permitted.

Note 1.— A CF/DF, or DF/DF sequence can only be used when the termination of the first leg is intended to be overflown, otherwise alternative coding needs to be used.

Note 2.— The IF leg is coded only when the altitude constraints at each end of the FA or HM leg are different.

Note 3.— The IF/RF combination is only permitted at the start of the final approach.

5. The following basic rules apply:

- a) FA, CA and VA should be followed by DF or CF (DF recommended);
- b) TF to flyover shall be followed by TF or CF;
- c) if a procedure requires a DF after a flyover then the previous leg shall be coded CF or DF;
- d) DF cannot follow a fly-by waypoint; and
- e) the waypoint at the start and end of an RF leg is not coded as flyover.

Note 1.— While most straight departures should start with a CA/DF sequence for the initial straight segment, if the first fly-by waypoint is less than 3 NM from the DER, experience has shown that it is preferable to start with a CF.

Note 2. — Where an initial departure turn is constrained by a distance from the DER and a minimum altitude, the application of an altitude constraint at the turning waypoint will not ensure that both constraints are met. A better method is to code the first leg as a CA and the second as a CF with the second leg course arranged to ensure that the earliest turn to intercept occurs at or after the required turning point.

6. Table III-2-5-App-3 defines the data required to support each path terminator:

Table III-2-5-App-3. Path terminators (Required data)

<i>Path terminator</i>	<i>Waypoint identifier</i>	<i>Flyover</i>	<i>Turn direction</i>	<i>Recommended Navaid</i>	<i>Distance from Navaid</i>	<i>Bearing from Navaid</i>	<i>Magnetic course</i>	<i>Path length</i>	<i>Altitude restriction 1</i>	<i>Altitude restriction 2</i>	<i>Speed limit</i>	<i>Vertical angle</i>	<i>Arc centre</i>
CA			0				✓		6		0		
CF	✓	1	0	✓	✓	✓	✓		0	0	0	0	
DF	✓	1	0	0	0	0			0	0	0		
FA	✓		0	✓	✓	✓	✓		6		0		
FM	✓		0	✓	✓	✓	✓		0		0		
HM	✓		0	0	0	0	✓	✓	0		0		
IF	✓			0	0	0			0	0	0		
RF	✓	0	✓	0		2	3	5	0	0	0	0	✓
TF	✓	0	0	0	0	0	0	0	0	0	0	0	
VA			0				4		6		0		
VI		0	0	0			4		0	0	0		
VM	0		0				4		0		0		
✓ — Required 0 — Optional 1 — Required for CF/DF and DF/DF combinations only. 2 — Inbound tangential track							3 — Outbound tangential track 4 — Heading not course 5 — Along track distance 6 — Altitude at or above						
Shaded spaces represent data that are not applicable to that path terminator.													

Chapter 6

APPLICATION OF FAS DATA BLOCK FOR SBAS AND GBAS

6.1 GENERAL

This chapter describes the guidance in construction and application of the FAS data block. Full descriptions of the FAS data blocks for SBAS and GBAS are provided in the appendices to this chapter. The descriptions provide the full encoding of the FAS data blocks as described in Annex 10, Volume I, and the avionics standards.

6.2 CONSTRUCTION

The procedure designer starts with detailed information on the runway (surveyed coordinates of both runway ends and runway orientation at the approach-end of the runway) and awareness of the airspace and obstacles relevant to the approach. From the runway coordinates, the typical path should be defined to pass over the runway threshold and be aligned with the runway. The following recommendations apply:

- a) *Glide path angle.* The glide path angle should be consistent with PAPI or VASI and typically would be 3 degrees. At runways with an ILS it is generally desirable to align the GPA with the ILS glide path, both to ensure alignment with existing lighting systems and to provide consistency between the two approach systems. If there are no existing lights or ILS, the recommended glide path angle is 3 degrees. Steeper approaches can be defined when necessary for obstacle clearance or compatibility with airspace requirements, but should not result in a descent rate in excess of 1 000 ft per minute for any aircraft.
- b) *Threshold crossing height.* For standard runways, paths should use a 15 m (50 ft) threshold crossing height. For short runways (e.g. runway Codes 1 and 2), the TCH should be 12 m (40 ft).
- c) *Approach alignment.* The approach should be aligned with the runway at the threshold. The desired alignment is used to determine the FPAP. Typically this alignment is accomplished by defining an initial FPAP location at the departure end of the runway.
- d) *Course width and GARP.* Guidance on these parameters is provided below (6.4.3).

6.3 REQUIRED NON-FAS DATA BLOCK FIELDS

The orthometric height of the LTP or FPAP, as related to the geoid, and presented as an MSL elevation should be defined to a tenth of a metre resolution. The LTP and FPAP orthometric heights are not included in the FAS data block, but are needed for the procedure construction and charting. These values are not CRC wrapped as part of the FAS data block.

6.4 QUALITY REQUIREMENTS

6.4.1 This is part of the quality assurance process. The quality requirements for the main data elements of the FAS are as follows:

<i>Data element</i>	<i>Accuracy</i>	<i>Resolution</i>	<i>Integrity</i>
FPAP (latitude and longitude)	0.3 m (1 ft)	0.0005" (0.01")	10 ⁻⁸
LTP/FTP (latitude and longitude)	0.3 m (1 ft)	0.0005" (0.01")	10 ⁻⁸
LTP/FTP (ellipsoidal height)	0.25 m	0.1 m	10 ⁻⁸
Approach TCH	0.5 m	0.05 m	10 ⁻⁸
Glide path angle	0.01°	0.01°	N/A
Course width	N/A	0.25 m	10 ⁻⁸
Delta length offset	N/A	8 m	N/A

Note 1.— The values between brackets are the ICAO Annex 15 requirements when different from the Annex 10 requirements. N/A stands for Not Available.

Note 2.— The 1×10^{-8} data integrity requirement can be met by conducting a flight evaluation after the FAS data block has been defined, provided the flight evaluation system verifies the CRC and determines that the approach path is acceptable.

6.4.2 Calculation and rounding considerations

6.4.2.1 *Need for rounding methodology.* Results are rounded after all calculations have been completed. It has been demonstrated that a difference in the calculation methodology or the rounding rules may lead to results (FPAP coordinates) exceeding the aforementioned accuracy requirements. It is thus deemed necessary to define a methodology to determine the FPAP coordinates and derived results (Δ FPAP) including rounding rules.

6.4.2.2 *Rounding methodology.* Results are rounded after all calculations have been completed. The resolution of the FAS main data is 0.0005 arc seconds. It is then proposed to apply the following rules:

- a) calculation inputs and outputs shall be rounded to 0.0005 arc seconds;
- b) calculations should be made in units of fractional arc seconds; and
- c) the rounding rules for arc seconds shall be as follows:
 - 1) If the number in the extra decimal place is 0, 1, or 2, the last character of the final value will be rounded down to 0;
 - 2) If the number in the extra decimal place is 3, 4, 5, 6 or 7, the last character of the final value will be rounded to 5; and
 - 3) If the number in the extra place is 8 or 9, the last character of the final value will be 0 and the preceding character is rounded up by 1.

6.4.3 Methodology for FPAP determination

6.4.3.1 The proposed methodology is applicable to approaches aligned with the runway. For offset approaches, an alternative method will have to be defined.

6.4.3.2 Two cases can be distinguished in the location of the FPAP:

- a) there is no existing ILS for the approach; and
- b) an ILS exists for the approach.

6.4.3.2.1 In case a), Figure III-2-6-1, the FPAP is located at the stop end of the runway (opposite from the LTP/FTP), the GARP at a distance of 305 m from the FPAP along the geodetic line from LTP/FTP to FPAP, and the Δ Length Offset equals zero. The FPAP coordinates are directly derived from WGS-84 survey (end of the runway), and the GARP coordinates are determined by geodetic calculation of the intersection between a geodetic line defined by (FPAP, LTP/FTP) and a distance of 305 m from the FPAP.

6.4.3.2.2 In case b), the GARP is assumed to be located at the localizer position, determined by WGS-84 surveys. As the FPAP shall not be placed before the stop end of the runway, it is first necessary to determine the distance between the localizer and the end of the runway by calculation of the geodetic distance from the localizer to the end of the runway.

6.4.3.2.2.1 If this distance is lower than 305 m, then the FPAP is set at the end of the runway (opposite LTP/FTP), the Δ length offset equals zero, and the GARP cannot coincide with the localizer. See Figure III-2-6-2. The GARP is calculated as the intersection between a geodetic line defined by (FPAP, LTP/FTP) and a distance of 305 m from the FPAP.

6.4.3.2.2.2 If the distance is (strictly) more than 305 m, the GARP coincides with the localizer. The FPAP is determined by the calculation of the intersection between the geodetic line defined by the LTP/FTP and the GARP, and a distance of 305 m from the GARP. Then the Δ Length offset is calculated as the distance between the FPAP and the runway end. See Figure III-2-6-3.

6.4.4 Offset procedures

Offset procedures are coded as straight-in approaches. The FTP is encoded rather than the LTP. The FAS data block descriptions in the appendices to this chapter include the encoding of offset procedures.

6.4.5 Procedure designer encoding format

Although Annex 10, Volume I, and the avionics standards, to a lesser degree, describe FAS data block encoding at the binary level, procedure designers should encode FAS data block elements in the alphanumeric format depicted in the appendices to this chapter. Conversion to binary format is part of the functional requirement of a standardized FAS data block software tool.

6.4.6 Standardized FAS data block software tool

It is highly recommended that a standardized FAS data block software tool be used. The software tool should:

- a) derive the FPAP Δ offsets for latitude and longitude from procedure designer entries for FPAP and LTP/FTP latitudes and longitudes;

- b) convert the procedure designer alphanumeric encoding of the FAS data block fields to binary format;
- c) construct the CRC remainder as described in Annex 10 and encode it as a hexadecimal value;
- d) provide a feedback mechanism to ensure the software tool has encoded what was intended by the procedure designer.

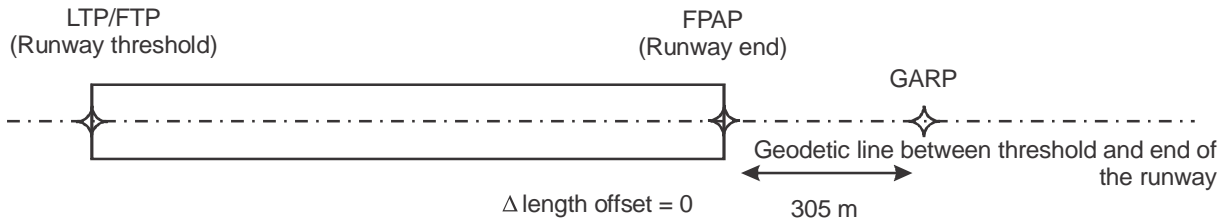

Figure III-2-6-1. FPAP location (no existing ILS for the approach)

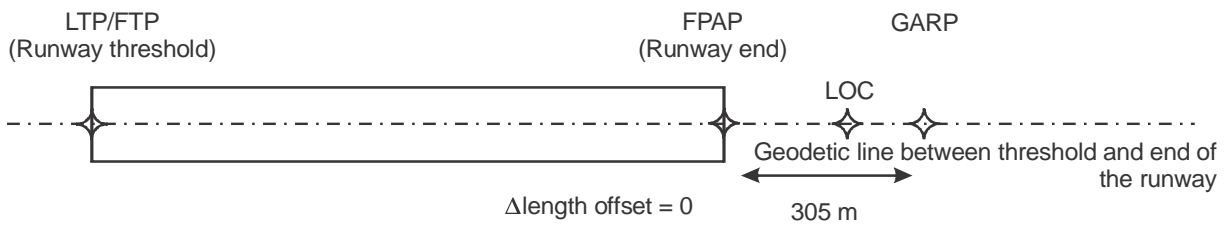

Figure III-2-6-2. FPAP location (ILS exists for the approach and LOC within 305 metres from runway end)

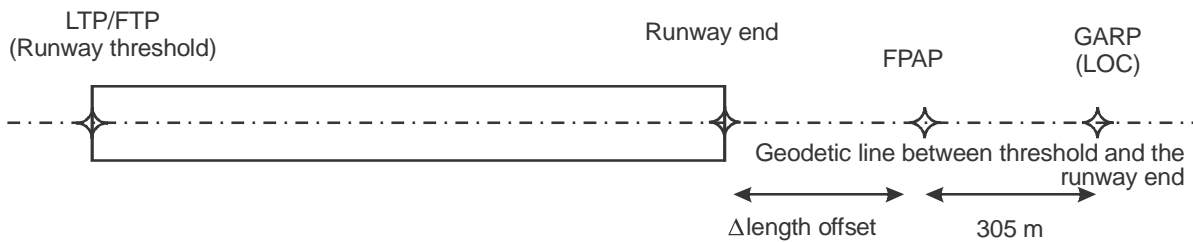

Figure III-2-6-3. FPAP location (ILS exists and LOC more than 305 m from the runway end)

Appendix A to Chapter 6

FAS DATA BLOCK DESCRIPTION FOR SBAS

1. GENERAL

The FAS data block is intended to protect the data and ensure that the procedure designer's intent is what is provided to the end user. Some elements of the FAS data block are not the responsibility of the procedure designer. All data used in the construction of the FAS data block requires the use of a high integrity quality control process. The procedure designer should provide alphanumeric input to an appropriate software tool that generates the binary string describing the FAS data block as well as the cyclic redundancy check (CRC) remainder. The standardized alphanumeric input of the elements of the FAS data block is described in this appendix.

Note.— For guidance material on the FAS data block, see Annex 10, Volume I, Attachment D, 6.6 and 7.11.

2. CONTENT OF THE FAS DATA BLOCK

2.1 There are twenty-one fields including the CRC remainder field. The first twenty fields are protected by the CRC. The encoding described here combines the runway number and runway letter, if appropriate into one field, resulting in one less field than described in Annex 10. This combining of runway number and letter into one field is expected by the FAS data block software tool which generates the binary format of runway number and letter in two fields. The specific encoding of the twenty-one fields is described in Annex 10. The specific order and coding of the fields shall be followed rigorously when computing the CRC to ensure avionics compatibility. Within the context of the FAS data block, the term TCH equates to the use of the term RDH. The following FAS data block information shall be stored as a binary string in the prescribed format, as described in Annex 10, and can only be transmitted electronically.

2.2 *FAS data fields.* The following presents a standardized alphanumeric encoding of fields needed for the final approach segment (FAS) data block record for approaches using SBAS (LPV minima) and are included in the CRC wrap:

<i>Data field</i>	<i>Field size</i>	<i>Data type</i>
Operation type	2 characters	Unsigned integer
Service provider identifier	2 characters	Unsigned integer
Airport identifier	4 characters	Alphanumeric
Runway	5 characters	Alphanumeric
Approach performance designator	1 character	Unsigned integer
Route indicator	1 character	Alpha
Reference path data selector	2 characters	Unsigned integer
Reference path ID (Approach ID)	4 characters	Alphanumeric
LTP/FTP latitude	11 characters	Alphanumeric
LTP/FTP longitude	12 characters	Alphanumeric
LTP/FTP ellipsoidal height	6 characters	Signed Integer
FPAP latitude	11 characters	Alphanumeric

FPAP longitude	12 characters	Alphanumeric
Threshold crossing height (TCH)	7 characters	Alphanumeric
TCH units selector (metres or feet)	1 character	Feet or metres
Glide path angle (GPA)	4 characters	Unsigned integer
Course width at threshold	5 characters	Unsigned integer
Length offset	4 characters	Unsigned integer
Horizontal alert limit (HAL)	3 characters	Numeric
Vertical alert limit (VAL)	3 characters	Numeric

2.3 *Integrity field.* This is the field needed for integrity monitoring, and is calculated using binary representation of the FAS data block (as described in Annex 10). The avionics, when “unwrapping” the FAS data block, must compare the resulting CRC remainder with the value provided by the procedure designer. If the values do not match, the FAS data block will not be used.

<i>Data field</i>	<i>Field size</i>	<i>Data type</i>
Precision approach path point data	8 characters	Hexadecimal
CRC remainder		

3. EXPLANATION OF FAS DATA BLOCK DATA FIELD ENTRIES

The explanation depicts the initial process in preparing data for inclusion in the FAS data block. This data is entered into a software tool, which is used to compute the CRC in accordance with Annex 10. The fields are discussed below (in the general order they appear in the FAS data block (items (a) through (u)). Non-FAS data block fields (but required data) are shown in items (v) and (w):

- a) *Operation type.* A number from 0 to 15 that indicates the type of the final approach segment.

Example: 0 is coded for a straight-in approach procedure including offset procedures. (Codes for other procedures are reserved for future definition.)

- b) *Service provider identifier.* A number from 0 to 15 that associates the approach procedure to a particular satellite-based approach system service provider as defined in Annex 10. A service provider identifier code of 15 implies any service provider (WAAS, EGNOS, etc.) may be used. A service provider code of 14 implies this FAS data block is not to be used by SBAS.

Example: 0 (WAAS), 1 (EGNOS), 2 (MSAS)

- c) *Airport identifier.* The four-character ICAO location identifier assigned to an airport. Where there is a national airport identifier but no ICAO location identifier, the three- or four-character national identifier is used. Where only three characters are provided, the trailing space is to be left blank.

Example: ICAO identifiers: KDEN, YSSY, NZWN, FAEL.
National identifiers: 3SL_, OH23.

- d) *Runway.* Runways are identified by two characters “RW” followed by the runway number. The fifth character is used where needed to indicate a left (L), right (R), or centre (C).

Examples: RW26R, RW 08L, RW18C, RW02

For SBAS circling only procedures, the runway number field shall be encoded as the procedure final approach course rounded to the closest 10° and truncated to two characters.

Notes:

1. *The runway number field valid range is 01 to 36.*
2. *For final approach courses from 355 degrees to 004 degrees, the truncated closest 10-degree expression is “36”.*

- e) *Approach performance designator.* A number from 0 to 7 that identifies the type of an approach. A “0” is used to identify an LPV approach procedure and a “1” indicates a Category I approach procedure. Other values are reserved for future use.

Example: 0 = LPV

- f) *Route indicator.* A single alpha character (Z to A or blank, omitting I and O) used to differentiate between multiple approaches to the same runway or heliport.

The route indicator coding shall match the duplicate procedure indicator used in the chart identification. The first procedure to a runway end shall be coded as “Z”, except when there is only a single procedure to the runway end. In this case, the field is coded as a blank. Additional alpha characters are incrementally assigned.

If multiple procedures to the same runway end differ only in the missed approach segments, the only difference in the coding of the FAS data blocks is the coding of the route indicator field so that it matches the duplicate procedure indicators used in the procedure titles.

Example: Z = 1st procedure

Y = 2nd procedure

X = 3rd procedure

- g) *Reference path data selector (RPDS).* This field is reserved for use by GBAS and is not used by SBAS.

Example: 0

- h) *Reference path identifier.* A four-character identifier that is used to confirm selection of the correct approach procedure. The leading character of the identifier references the system providing service (e.g. “W” WAAS, “E” EGNOS, “M” MSAS) followed by the runway number. The last character, beginning with the letter “A”, excluding the letters “C”, “L”, and “R”, will be used to define the first procedure, followed by succeeding letter for each procedure to a particular runway. For example, an airport has 3 parallel runways and the left and right runways have both a straight-in procedure and an offset procedure; the centre runway has a straight-in procedure only. The following (extreme) examples would be applicable:

Example: W09A & W09B would define the two unique FAS data blocks to Rwy 09L.

W09D would be used to define the FAS data block for Rwy 09C.

W09E & W09F would be used to define the FAS data blocks for Rwy 09R.

For circling only procedures, the two digit runway number should be encoded as the procedure final approach course rounded to the nearest 10° and truncated to two characters.

Note 1.— These suffixes do not have to be in any particular order so as to allow procedures to be added at a later time without changing existing FAS data blocks.

Note 2.— For final approach courses from 355 degrees to 004 degrees, the truncated closest 10-degree expression is “36”.

For SBAS, the reference path identifier is charted and is used by the avionics to confirm to the crew that the correct procedure has been selected.

- i) *Landing threshold point (LTP)/Fictitious threshold point (FTP) — Latitude.* Represents the latitude of the threshold defined in WGS-84 coordinates and entered to five ten thousandths of an arc second. An example depicting latitude follows:

225436.2125N (11 characters) for 22°54'36.2125" N

- j) *Landing threshold point (LTP)/Fictitious threshold point (FTP) — Longitude.* Represents the longitude of the threshold defined in WGS-84 coordinates and entered to five ten thousandths of an arc second. An example depicting longitude follows:

1093247.8780E (12 characters) for 109°32'47.8780" E

- k) *LTP/FTP height relative to the ellipsoid (HAE).* The height expressed in metres referenced to the WGS-84 ellipsoid. The first character is a + or – sign and the resolution value is in tenths of metres with the decimal point suppressed.

Example: +00356 (+35.6 m), -00051(-5.1 m), +01566 (+156.6 m), -00022 (-2.2 m)

- l) *Flight path alignment point (FPAP) — Latitude.* A point located on a geodesic line or an extension of a geodesic line calculated between the LTP and the designated centre of the opposite runway-landing threshold. It is positioned at a distance from the LTP to support a prescribed procedure design angular splay and course width, as well as functionality associated with an aircraft. It is used in conjunction with the LTP to determine the lateral alignment of the vertical plane containing the path of the RNAV final approach segment. On shorter runways, the FPAP may be located off the departure end of the landing runway. The latitude of the runway FPAP is defined in WGS-84 coordinates and entered to five ten thousandths of an arc second. An example depicting latitude follows:

225436.2125N (11 characters) for 22°54'36.2125" N

Note 1.— Annex 10 describes the encoding of the FPAP latitude as a Δ offset from the LTP/FTP latitude. The encoding here assumes the software tool generating the FAS data block binary code calculates the offset.

Note 2.— For offset procedures, the FPAP is located on the extension of the final approach course, at a distance from the FTP that provides the appropriate lateral course width.

- m) *FPAP — Longitude.* The longitude of the runway FPAP is defined in WGS-84 coordinates and entered to five ten thousandths of an arc second. An example depicting longitude follows:

1093247.8780E (12 characters) for 109°32'47.8780" E

Note.— Annex 10 describes the encoding of the FPAP longitude as a Δ offset from the LTP/FTP longitude. The encoding here assumes the software tool generating the FAS data block binary code calculates the offset.

- n) *Threshold crossing height (TCH).* The designated crossing height of the flight path angle above the LTP (or FTP). The allowable range of values is defined in Annex 10.

Example: 00055.0 (55.0 ft); 00042.0 (42.0 ft)

- o) *TCH units selector.* This character defines the units used to describe the TCH.

Example: F = feet M = metres

- p) *Glide path angle*. The angle of the approach path (glide path) with respect to the horizontal plane defined according to WGS-84 at the LTP/FTP. It is specified in hundredths of a degree.

Example: 02.75 (2.75°), 06.20 (6.20°), 03.00 (3.00°)

- q) *Course width at threshold*. The semi-width (in metres) of the lateral course width at the LTP/FTP, defining the lateral offset at which the receiver will achieve full-scale deflection. In combination with the distance to the FPAP, the course width defines the sensitivity of the lateral deviations throughout the approach. The allowable range varies from 80 m to 143.75 m. The course width at threshold is rounded to the nearest 0.25 m. When the procedure is designed to overlie an ILS/MLS procedure, use the course width at the threshold value from the flight inspection report of the underlying ILS/MLS system. If the localizer (azimuth) course width is less than 80 m, use 80 m as the default value. For offset procedures, use the course width at the FTP.

Example 106.75

- r) *Δ length offset*. The distance from the stop end of the runway to the FPAP. It defines the location where lateral sensitivity changes to the missed approach sensitivity. The value is in metres with the limits being 0 to 2 032 m. The actual distance is rounded up to the nearest value divisible by 8. If the FPAP is located at the designated centre of the opposite runway end, the distance is zero. For offset procedures, the Δ length offset is coded as zero.

Example: 0000, 0424

- s) *Horizontal alert limit (HAL)*. The HAL is the radius of a circle in the horizontal plane (the local plane tangent to the WGS-84 ellipsoid), with its centre being at the true position, that describes the region which is required to contain the indicated horizontal position with the required probability for a particular navigation mode assuming the probability of a GPS satellite integrity failure being included in the position solution is less than or equal to 10^{-4} per hour. The range of values is 0 to 50.8 m with a 0.2 m resolution. The HAL, for LPV procedures, is a fixed value at 40.0 m.

Example: HAL 40.0

Note.— The HAL field is not part of the FAS data block/CRC wrap for GBAS procedures.

- t) *Vertical alert limit (VAL)*. The VAL is half the length of a segment on the vertical axis (perpendicular to the horizontal plane of the WGS-84 ellipsoid), with its centre being at the true position, that describes the region which is required to contain the indicated vertical position with a probability of 1.0×10^{-7} per approach, assuming the probability of a GPS satellite integrity failure being included in the position solution is less than or equal to 10^{-4} per hour. The range of values is 0 to 50.8 m with a 0.2 m resolution.

Note 1.— A VAL of 00.0 indicates that the vertical deviations should not be used (i.e. a lateral only (localizer performance (LP)) approach).

Note 2.— The VAL field is not part of the FAS data block/CRC wrap for GBAS procedures.

Example: VAL 50.0 VAL 12.0

- u) *Precision approach path point CRC remainder*. An 8-character hexadecimal representation of the calculated remainder bits used to determine the integrity of the FAS data block data during transmission and storage. This information will be computed electronically with use of the electronic transmittal software (FAS data block software tool) and is documented appropriately.

Example CRC remainder: E104FC14

v) *ICAO code*. The first two designators of the ICAO code number, as identified in ICAO Doc 7910.

Example: K2, PA

w) *Orthometric height*. The height of the LTP/FTP as related to the geoid and presented as an MSL elevation to a tenth of a metre with the decimal point suppressed. The value is preceded by “+” or “-”.

Example: +00362 (36.2 m) -00214 (-21.4 m)

4. MAIN DATA ELEMENTS FOR THE PROCEDURE DESIGNER

Considering the reference material mentioned in the previous paragraph, the main data necessary for the FAS determination, from the procedure design perspective, include:

- a) the LTP/FTP latitude, longitude and height above/below WGS-84 ellipsoid;
- b) the FPAP latitude and longitude, and then the offset between FPAP and LTP/FTP called Δ FPAP (latitude and longitude);
- c) the approach threshold crossing point height above LTP/FTP;
- d) the glide path angle;
- e) the course width at threshold; and
- f) the distance from the end of the runway to the FPAP (Δ length offset).

Items c), d) and e) are determined by the procedure designer.

Note.— The GPA generally equals 3 degrees. The TCH is normally the same as the one published for the ILS procedure if it exists. The course semi-width value is generally 105 m for equivalence with ILS procedures.

When the FPAP has been determined, calculation of the Δ FPAP and Δ length offset can be made.

5. ENCODING OF THE FAS DATA BLOCK FOR OFFSET PROCEDURES

5.1 For offset procedures not referenced to the landing threshold point (LTP), the FAS data block is encoded as shown in this appendix with the following additions:

- a) Operation type

00 = offset approach.

- b) Landing threshold point (LTP)/fictitious threshold point (FTP) — latitude

The FTP latitude is encoded.

- c) Landing threshold point (LTP)/fictitious threshold point (FTP) — longitude

The FTP longitude is encoded.

- d) LTP/FTP height above ellipsoid (HAE)

The HAE of the FTP is encoded as the HAE of the LTP.

- e) Threshold crossing height

The height the glide path crosses above the FTP is encoded.

- f) Course width at threshold

Encode the course width at the FTP.

- g) Δ length offset

The Δ length offset is encoded as zero.

5.2 *Location of the FTP relative to the LTP.* For offset procedures, the FTP is located on the arc radius originating at the intersection of the final approach course and the extended runway centre line and drawn through the LTP. This orientation is depicted in Figure III-2-6-App A-1. For aligned procedures, not coded relative to the LTP, the FTP lies on the runway centre line or its extension.

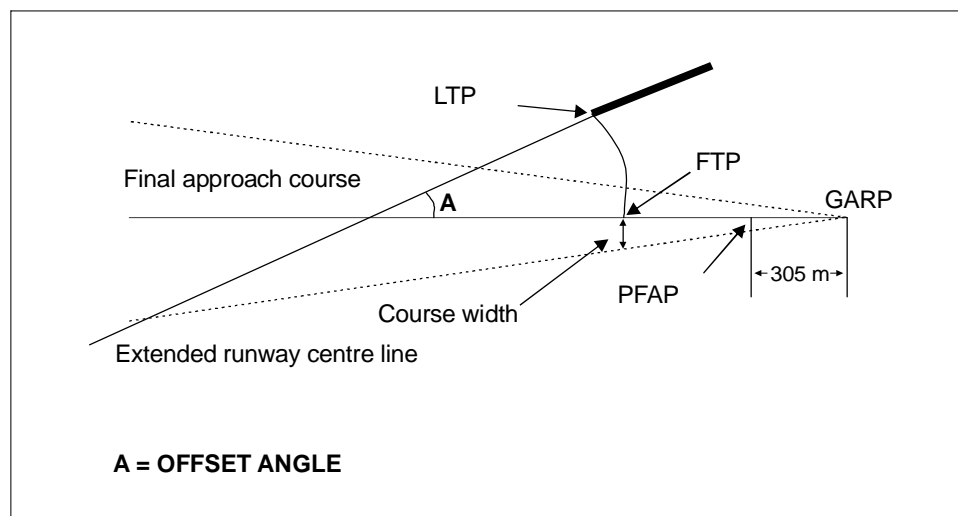

Figure III-2-6-App A-1. Location of FTP relative to LTP

Appendix B to Chapter 6

ENCODING OF THE GBAS FAS DATA BLOCK

1. GENERAL

1.1 The FAS data block is intended to protect the data and ensure that the procedure designer's intent is what is provided to the end user. Some elements of the FAS data block are not the responsibility of the procedure designer. The cyclic redundancy check (CRC) must be computed by a software tool. The procedure designer should provide alphanumeric input to an appropriate software tool that generates the binary string describing the FAS data block. The standardized alphanumeric input of the elements of the FAS data block is described below.

1.2 All data used in the construction of the FAS data block requires the use of a high integrity quality control process. The FAS data block data content must be protected by this quality control process. The software tools used in this quality control process must ensure the procedure designer's intent is what is provided to the end user. The description in this appendix identifies the differences from the description of encoding the SBAS FAS data block in Appendix A to Chapter 6.

Note.— For guidance material on the FAS data block, see Annex 10, Volume I, Attachment D, 6.6 and 7.11.

2. STRUCTURE AND CONTENT OF THE GBAS FAS DATA BLOCK

Note.— The definition and encoding of the GBAS FAS data block are found in Annex 10, Volume I, Appendix B, Section 3.6.4.5 and Table B-66.

3. DIFFERENCES IN ENCODING THE GBAS FAS DATA BLOCK

3.1 *Operation type.* Provides information indicating whether the operation is a straight-in path or other operation to be defined later. The coding convention is as follows:

- 0 = straight-in which includes offset procedures.
- 1–15 = spare.

3.2 *SBAS service provider.* Used only by SBAS.

3.3 *Approach performance designator.* This field represents the general information about the approach design. The coding convention is as follows:

- 0 = APV
- 1 = Category I
- 2 = reserved for Category II
- 3 = reserved for Category III
- 4–7 = spare.

3.4 *Reference path data selector (RPDS)*. The RPDS is a numerical identifier that is unique on a frequency in the broadcast region and used to select the FAS data block.

Note 1.— The RPDS is the only identifier guaranteed to be unique to one FAS data block among all the FAS data blocks within radio range of the ground reference station on the tuned frequency.

Note 2.— Numerical identifier values 0–48 are selected via receiver channelling.

3.5 *Reference path identifier*. Encoded the same as for SBAS except the leading alpha character distinguishes it from an SBAS procedure.

Example: G09A or L09A.

The horizontal alert limit (HAL) and the vertical alert limit (VAL) are not included in the GBAS FAS data block.

SECTION 3
PROCEDURE CONSTRUCTION

Chapter 1

DEPARTURE PROCEDURES

1.1 GENERAL

1.1.1 Application

1.1.1.1 This chapter describes the departure criteria for PBN procedures (see Table III-1-1-1).

1.1.1.2 The general criteria of Part I, Section 3 and Part III, Sections 1 and 2 as amplified or modified by the criteria in this chapter apply to PBN departure procedures.

1.1.2 Secondary areas

The principle of secondary areas applies to straight segments (see Part I, Section 2, Chapter 1, 1.2 and 1.3). Secondary areas are limited to the part of the procedure where the total width of the primary area is at least equal to the area semi-width at the first waypoint, as shown in Table III-3-1-1. See Figure III-3-1-1.

1.1.3 Minimum segment length

Minimum segment length distances are listed in the tables in Section 2, Chapter 1. For construction of the average flight path see Part I, Section 3, Appendix to Chapter 3.

1.1.4 Area widths

1.1.4.1 The total area width results from joining the various area widths at the relevant fixes. For the calculation of area widths and the underlying tolerances involved in these calculations, see the paragraph entitled “XTT, ATT and area semi-width” in Section 1 for the appropriate sensor. These are:

- a) DME/DME, Section 1, Chapter 3, 3.6;
- b) GNSS, Section 1, Chapter 2, 2.2.

1.1.4.2 Where more than one sensor type is allowed to be used, e.g. in RNAV 1, apply the greater of the XTT, ATT and $\frac{1}{2}$ A/W values at each waypoint.

1.2 STRAIGHT DEPARTURES

The alignment of the initial departure track ($\alpha \leq 15^\circ$) is determined by the position of the first waypoint located after the departure end of the runway (DER).

1.3 AREA WIDTH AT THE BEGINNING OF THE DEPARTURE

1.3.1 For the construction of the area width at the beginning of the departure, the general criteria apply (see Part I, Section 3) until the splaying boundaries reach the outer boundary of the fictitious area (see Figure III-3-1-2) from where it follows the width of the fictitious area until the first waypoint of the departure procedure. The fictitious area begins at the DER and extends to the first waypoint. The area semi-width of this area at the DER and at the first waypoint varies according to sensor type (see Table III-3-1-1).

1.3.2 After the initial splay at the DER, the area width changes at 15 NM from the ARP and then at 30 NM from the ARP. At each change, a 15° splay on either side of track is used in accordance with the methodology detailed in Section 1, Chapter 1, 1.5.3. See Figure III-3-1-2.

1.4 TURNING DEPARTURES

1.4.1 General

1.4.1.1 Four kinds of turns can be prescribed:

- a) turn at a “fly-by” waypoint;
- b) turn at a “flyover” waypoint (which corresponds to a turn at a designated TP);
- c) turn at an altitude/height; and
- d) fixed radius (RF) turns.

1.4.1.2 For fly-by and fly-over turns, in order for the aircraft to properly execute the turn, each single specified turn should be at least 5° and must not exceed 120°. However, the maximum value of 120° does not apply to the case of a turn (at either altitude/height or at a designated TP) with a free turn back to a waypoint. An RF turn shall be between 2° and 358°.

1.4.1.3 Modified straight departure criteria are applied to any radius to fix (RF) leg. The design methodology for RF turns on departure is as follows:

- a) During the initial departure, as GNSS is used, the ATT value at any point along the path is reduced in proportion to the area semi-width value (as determined by the splay) as derived from the following formula, using SI units:

$$\text{Reduced ATT} = \left\{ \frac{ATT - 120}{\frac{\frac{1}{2} AW - 150}{\tan 15^\circ}} \right\} x + 120$$

Where x is the distance, in metres, from the DER;
 ATT is the full value appropriate to the RNP accuracy (see Section I, Chapter 2, 2.2.2);
 120 m represents the reduced ATT at the DER; and
 $\frac{1}{2} AW$ is the value appropriate to the RNP accuracy (see Section 1, Chapter 2, 2.2.3).

The ATT value is not reduced if the initial departure is based upon other positioning sources.

- b) The minimum distance from the DER to the waypoint at the start of the RF turn shall be 1 852 m (1 NM). If the PDG does not reach 120 m (294 ft) above the DER prior to the earliest ATT at the start of the RF leg, an additional climb gradient shall be published, from a point 35 ft above the DER to at least 400 ft above the AD altitude at the earliest ATT, and an appropriate altitude restriction shall be published at the waypoint.
- c) The track length from the DER to the end of the RF shall be calculated along the nominal track based upon a nominal radius.
- d) The height above the aerodrome and the associated design IAS value at the end of the RF leg shall be based upon a climb gradient along the nominal track as determined by the designer but not lower than 10 per cent. A speed limit may be promulgated for the end of the RF leg if a smaller radius is required.
- e) The TAS at the end of the RF shall be calculated using the appropriate maximum temperature value above ISA for the aerodrome. The appropriate wind value shall be added to the TAS prior to calculating the actual radius of turn.
- f) If the MOC is less than or equal to 75 m (246 ft) (CAT H: 65 m (213 ft)), as defined in Part I, Section 3, Chapter 2, the OIS is lowered to take account of body geometry (BG) from a point “ATT” prior to the start of the RF leg. The OIS is kept level from that point until BG protection has been reached. The 0.8 per cent D + BG OIS is maintained during the RF turn until 75 m (246 ft) (CAT H: 65 m (213 ft)), MOC is reached.

$$BG = \text{wing semi-span} * \sin(\alpha + 5)$$

Where:

α is the angle of bank

wing semi-span = 40 m (132 ft)

This is illustrated in Figure III-3-1-1.

- g) The 2.5 per cent OIS gradient is based upon the track between the two waypoints defined by a radius of $r - 186$ m ($r - 0.1$ NM) with a PDG of 3.3 per cent.

1.4.2 Turn protection

For turn protection at a fly-by, flyover, turning altitude/height or RF turn, see Section 2, Chapter 2, “Turn protection and obstacle assessment.”

Table III-3-1-1. Area semi-width of the fictitious area

<i>Procedure type</i>	<i>Area semi-width</i>
RNAV 2	4.19 km (2.26 NM) if DME updating allowed, else 3 704 m (2.00 NM)
RNAV 1	3 111 m (1.68 NM) if DME updating allowed, else 3 704 m (2.00 NM)
RNP-1	3 704 m (2.00 NM)

1.4.3 Promulgation

The following criteria apply to RF turns on departures:

- a) If the PDG does not reach 120 m (394 ft) at the start of the RF turn, an additional gradient and an altitude restriction at the waypoint shall be published.
- b) The path descriptor sequence for initial legs should be IF/TF/RF/TF or IF/TF/RF/RF/TF.

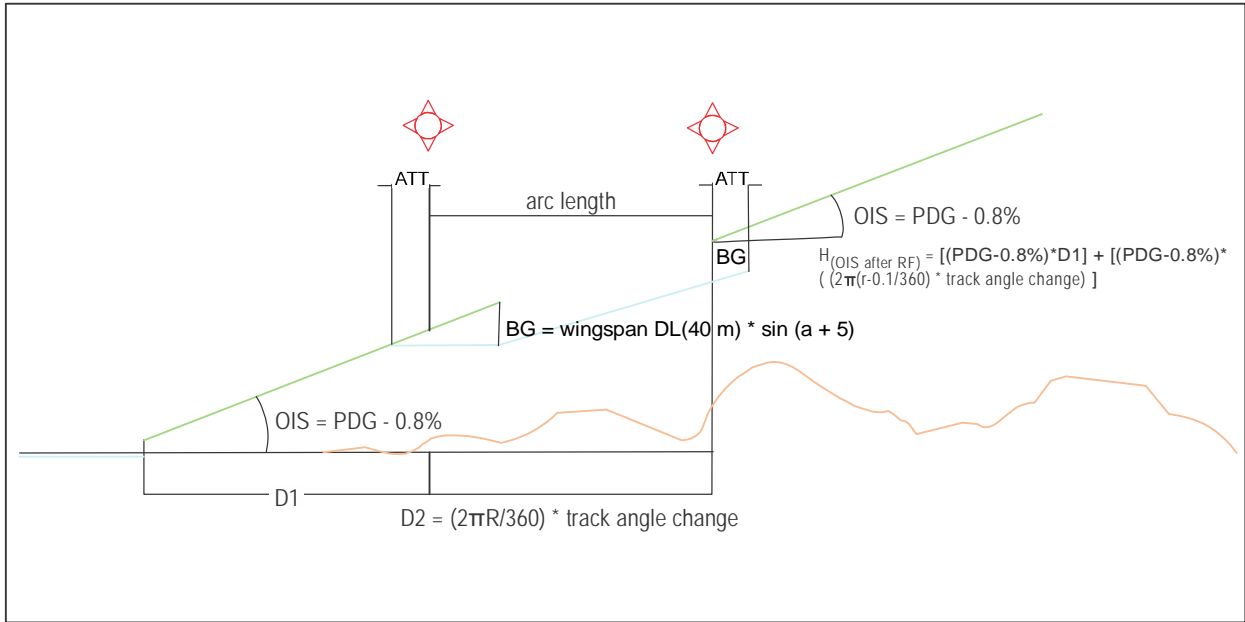

Figure III-3-1-1. RF initial departure

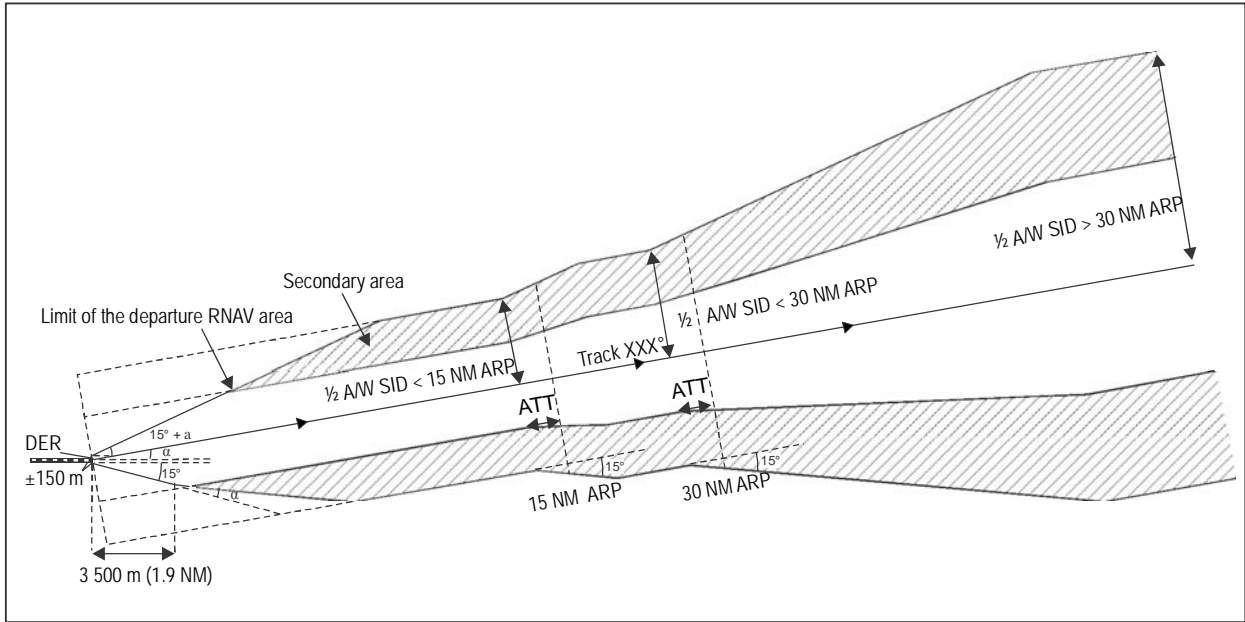

Figure III-3-1-2. Straight departure

Chapter 2

ARRIVAL AND APPROACH PROCEDURES

2.1 GENERAL

2.1.1 Application

2.1.1.1 This chapter describes the arrival, initial and intermediate approach and final missed approach criteria for PBN procedures (see Table III 1 1-1). The criteria for the final approach, initial and intermediate missed approach are specific to the approach classification (NPA, APV and precision) and are dealt with in separate chapters.

Note.— The criteria for RNP AR APCH procedures are detailed in the Required Navigation Performance Authorization Required (RNP AR) Procedure Design Manual (Doc 9905).

2.1.1.2 The general criteria of Part I and Part III, Sections 1 and 2, as amplified or modified by the criteria in this chapter, apply to PBN arrival and approach procedures.

2.1.2 Secondary areas

The general criteria for secondary areas apply (see Part I, Section 2, Chapter 1, 1.2 and 1.3).

2.1.3 Minimum segment length

Minimum segment length distances are listed in the tables in Section 2, Chapter 1.

2.1.4 Area widths

2.1.4.1 For the calculations of area widths and the underlying tolerances involved in these calculations, see the paragraph entitled “XTT, ATT and area semi-width” in Section 1 for the appropriate sensor. These are:

- a) DME/DME, Section 1, Chapter 3, 3.6; and
- b) GNSS, Section 1, Chapter 2, 2.2.

2.1.4.2 The total area width results from joining the various area widths at the relevant fixes, with the exception of the interfaces between the intermediate segment and the final approach segment, and between the en-route segment and the initial approach segment where the methodology detailed in Part III, Section 1, Chapter 1, 1.5 shall be applied.

2.1.5 Y- or T-bar design concept for RNAV procedures

For a detailed description of non-precision approach procedures based on the Y- or T-bar concept, refer to Section 2, Chapter 3, “RNAV T- or Y-bar procedure construction”.

2.2 ARRIVAL ROUTES

2.2.1 General

Arrival obstacle clearance criteria shall apply up to the initial or intermediate approach fix (see Part I, Section 4, Chapter 2). See Figures III-3-2-1 and III-3-2-2.

2.2.2 Minimum sector altitude/terminal arrival altitude

For terminal arrival altitude see Section 2, Chapter 4, “Terminal arrival altitude (TAA)”. Where TAAs are not provided, a minimum sector altitude shall be published. The provisions of Part I, Section 4, Chapter 8, “Minimum sector altitudes (MSA)” apply except that only a single omnidirectional sector shall be established in the case of GNSS. The sector is centred on the latitude and longitude of the aerodrome reference point.

2.3 INITIAL APPROACH SEGMENT

2.3.1 Straight segments

2.3.1.1 *Initial approach alignment*

2.3.1.1.1 For non-precision approach procedures, the angle of interception between an initial approach track and another initial track shall not exceed 120°. Track changes greater than 90° at a waypoint should be avoided. Turns greater than 90° should be accommodated by more than one waypoint or by use of an RF leg.

2.3.1.1.2 The angle of interception between an initial approach track and the intermediate track shall not exceed 90°.

2.3.1.1.3 For approach procedures with vertical guidance and precision approach procedures, the angle of interception between the initial approach track and the intermediate track shall not exceed 90°.

2.3.1.2 *Initial approach area length.* For GNSS the optimum length of the initial approach segment is 9 km (5 NM) (Cat H, 6 km (3 NM)). If the initial segment is preceded by an arrival route, the minimum length is 11.1 km (6.0 NM) to allow for blending.

2.3.1.3 *Initial approach area width.* The general criteria in Part I, Section 4, Chapter 3, 3.3.3, “Area”, apply as modified in this chapter. The total area width results from joining the various area widths at the relevant fixes. The principle of secondary areas applies. For area widths, see 2.1.4, “Area widths”.

2.3.2 Turn protection

For turn protection at a fly-by, flyover or fixed radius turn, see Section 2, Chapter 2, “Turn protection and obstacle assessment.”

(See also examples in Figures III-3-2-3 and III-3-2-4.)

2.3.3 Reversal procedures

RNAV procedures should be designed to avoid the need for reversal procedures. However, when a procedure requires a track reversal, a racetrack pattern shall be established.

2.4 INTERMEDIATE APPROACH SEGMENT

2.4.1 Intermediate approach alignment

2.4.1.1 For non-precision approach procedures, the intermediate approach segment should be aligned with the final approach segment whenever possible. If a turn at the FAF is required, the angle shall not exceed 30° (Cat H, 60°) on a fly-by turn. If the intermediate segment contains an RF leg, the criteria in paragraph 2.4.1.4 apply. Fly-over turns are not permitted.

2.4.1.2 For approach procedures with barometric vertical guidance, the intermediate segment should be aligned with the final approach segment. If a fly-by turn at the FAF is required, the angle shall not exceed 15° (CAT H 30°). Fly-over turns are not permitted. If the intermediate segment contains an RF leg, the criteria in paragraph 2.4.1.4 apply.

2.4.1.3 For SBAS APV and CAT I approach procedures, the intermediate segment should be aligned with the final approach segment. Fly-by and fly-over turns at the FAF/FAP are not permitted. If the intermediate segment contains an RF leg, the criteria in paragraph 2.4.1.4 apply.

2.4.1.4 If the intermediate segment contains an RF segment that ends at the FAF, the following criteria apply:

- a) the track angle change of the RF leg shall not exceed 45°; and
- b) the minimum radius shall be 4 723 m (2.55 NM) (see Figure III-3-2-1).

2.4.1.5 For precision approach procedures other than SBAS CAT I, the intermediate approach segment shall be aligned with the final approach segment.

2.4.2 Intermediate approach length

2.4.2.1 The intermediate segment with a fly-by turn at the IF consists of two components:

- a) a turning component followed by
- b) a straight component immediately before the final approach waypoint.

2.4.2.2 The length of the straight component is variable but will not be less than 3.70 km (2.00 NM). This allows the aircraft to be stabilized prior to overflying the final approach waypoint. The length of the turning component is the minimum stabilization distance for the turn angle at the IF and can be determined from Section 2, Chapter 1, Table III-2-1-3 or III-2-1-9.

2.4.2.3 When an RF is used in the intermediate segment, the total length of the intermediate segment, including curved and straight legs, shall not be less than 3 704 m (2 NM).

2.4.2.4 For GBAS specific criteria apply (see Chapter 6).

2.4.3 Intermediate approach area width

DME/DME and GNSS. The total area width results from joining the area widths at the IF and the FAF. The principle of secondary areas applies.

2.4.4 Protection of turns at the FAF

See Section 2, Chapter 2, “Turn protection and obstacle assessment.”

2.5 TURNING MISSED APPROACH

The general criteria in Part I, Section 4, Chapter 6, 6.4.2, “General” and 6.4.3, “Turn parameters” apply. See also 6.4.6.4, “Obstacle clearance in the turn area” and 6.4.7, “Turn specified at the MAPt”. For turn protection and obstacle assessment see Section 2, Chapter 2, “Turn protection and obstacle assessment.” For missed approach procedures with GNSS receivers which do not provide continuous track guidance after the MAPt, only a DF leg should be used for the design of the first segment of the missed approach.

2.6 END OF THE MISSED APPROACH SEGMENT

A waypoint defining the end of the missed approach segment shall be located at or after the point where the aircraft, climbing at the minimum prescribed gradient for each segment, reaches the minimum altitude for en route or holding, whichever is appropriate.

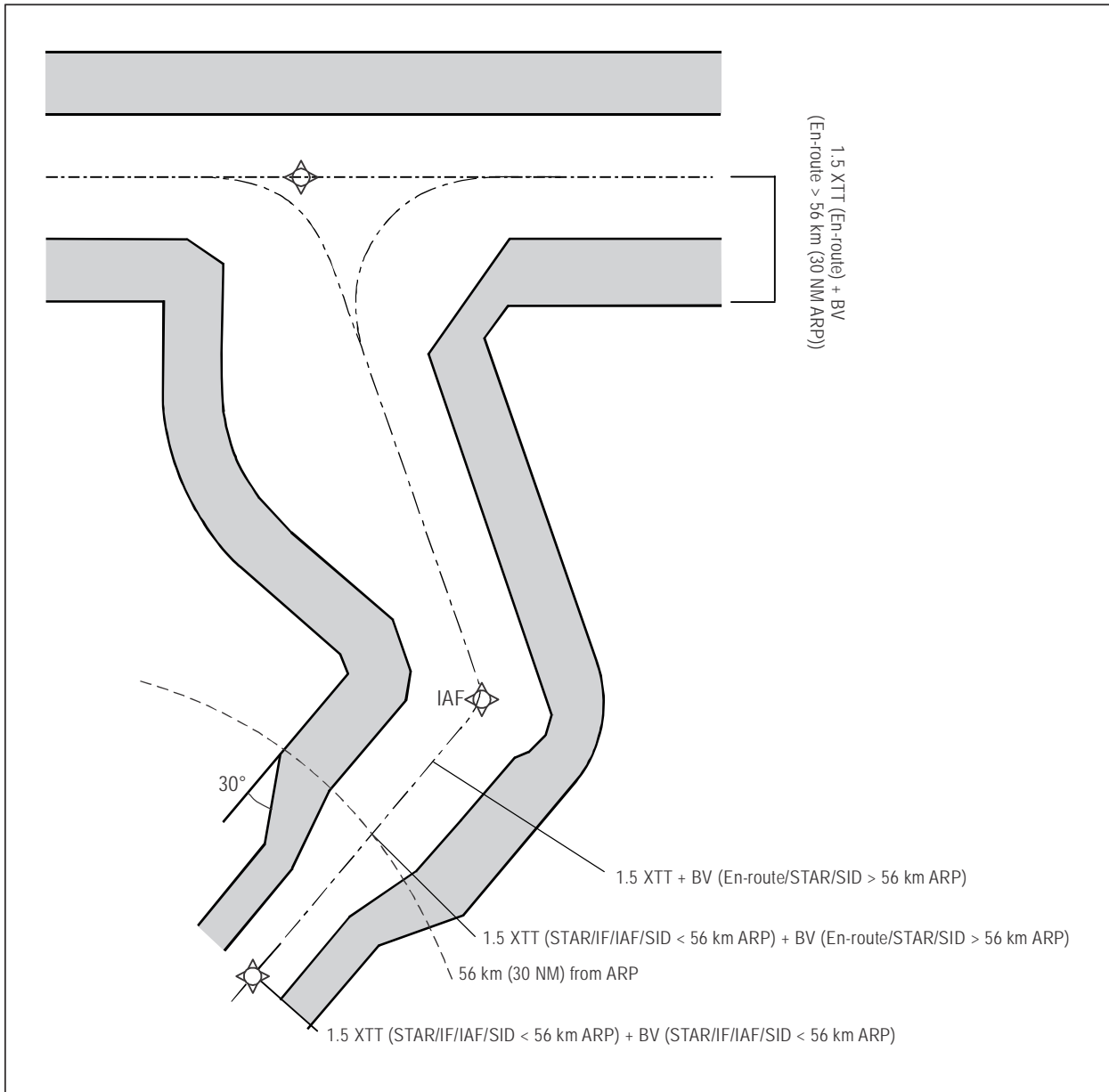

Figure III-3-2-1. Arrival — IAF greater than or equal to 56 km (30 NM) ARP

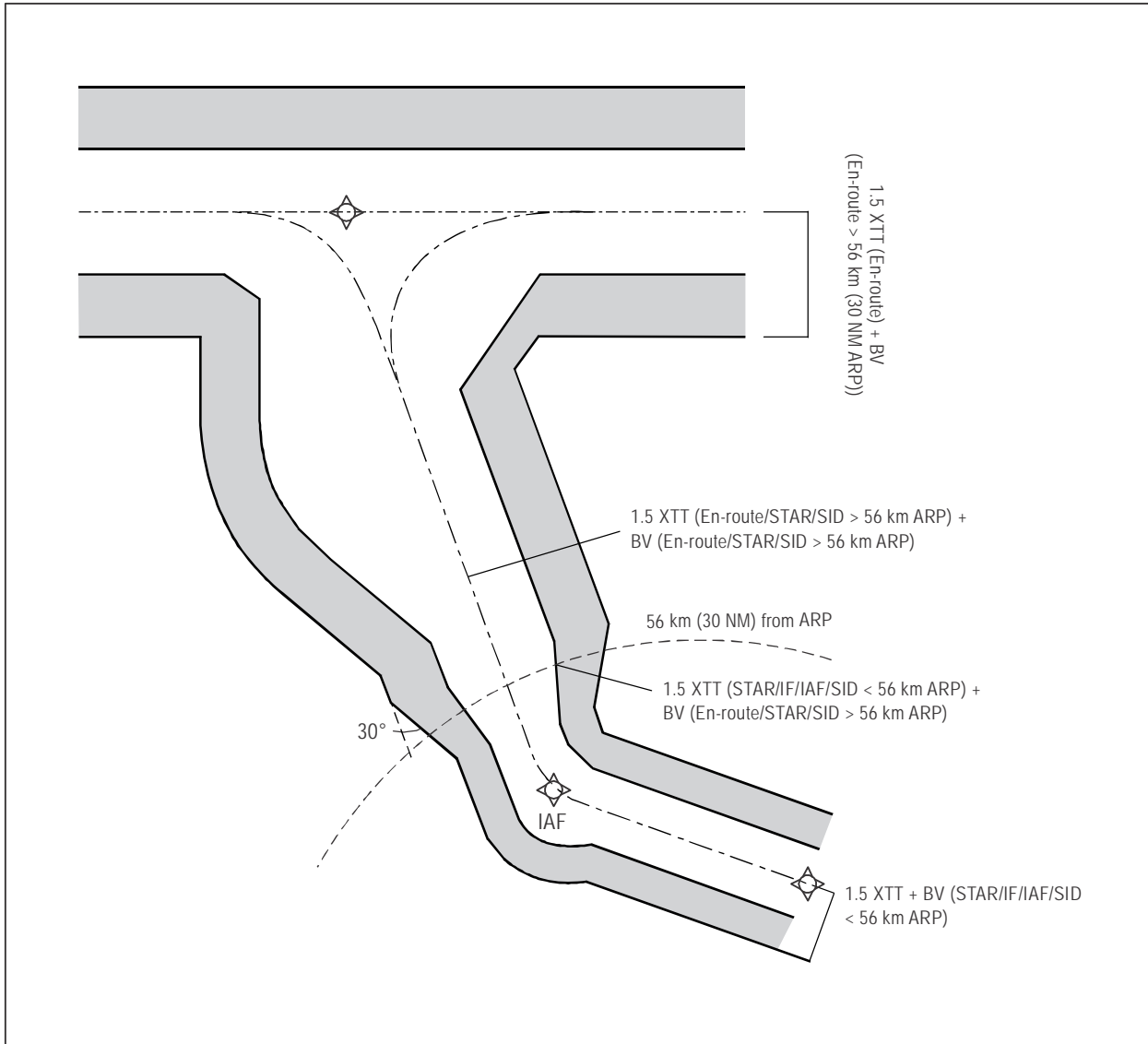

Figure III-3-2-2. Arrival — IAF less than 56 km (30 NM) ARP

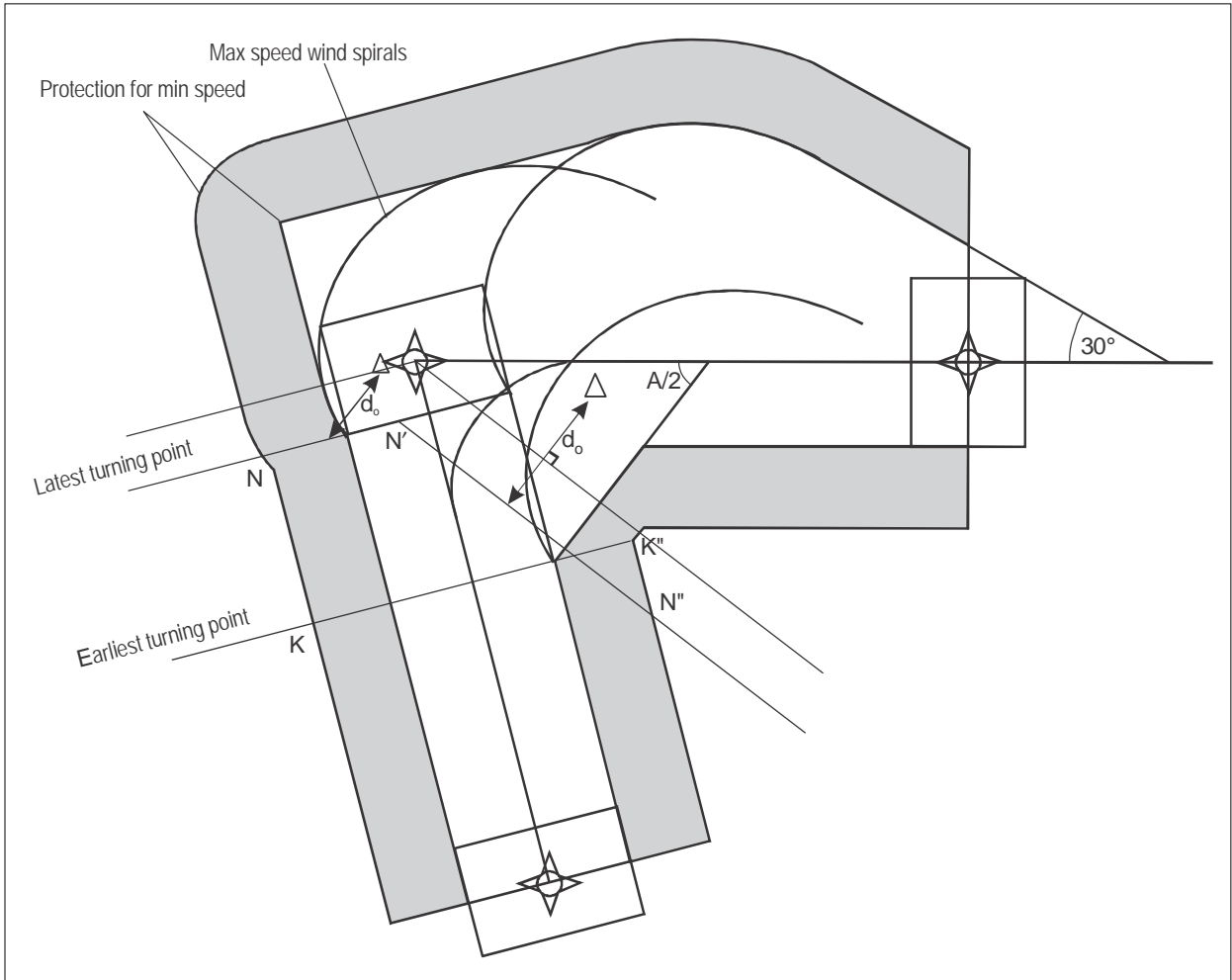

Figure III-3-2-3. Turn at a fly-by waypoint

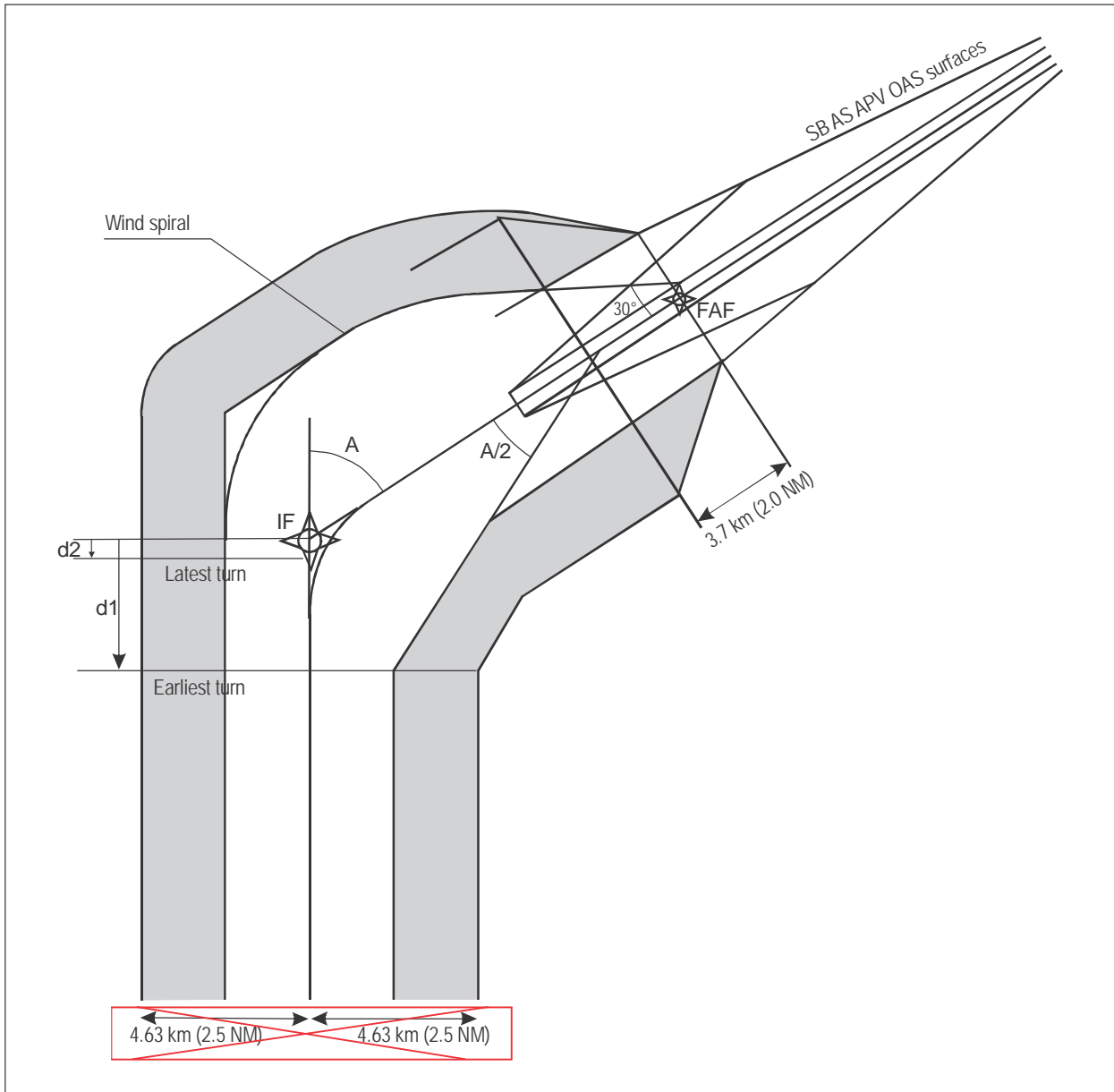

Figure III-3-2-4. Turn at a fly-by waypoint (SBAS)

Chapter 3

NON-PRECISION APPROACH PROCEDURES

3.1 GENERAL

3.1.1 Application

3.1.1.1 This chapter describes the non-precision approach criteria for RNP APCH procedures.

3.1.1.2 The general criteria of Part I, Section 3 and Part III, Sections 1 and 2 as amplified or modified by the criteria in this chapter apply.

3.2 FINAL APPROACH SEGMENT

3.2.1 Final approach alignment

The final approach track should be aligned with the runway centre line; if this is not possible, the criteria in Part I, Section 4, Chapter 5, 5.2, “Alignment” apply.

3.2.2 Final approach length

The optimum length is 9.3 km (5.0 NM) (Cat H, 3 704 m (2.0 NM)), but it should normally not exceed 18.5 km (10 NM). The minimum length of the final segment and distance between FAF and threshold shall not be less than 5.6 km (3.0 NM) except for Cat H.

3.2.3 Final approach area width

3.2.3.1 The principle of secondary areas applies.

3.2.3.2 The final approach segment area is derived from the area semi-width published for the MAPt and the merging methodology detailed in Part III, Section 1, Chapter 1, 1.5.3.

3.2.3.3 For area widths see Part III, Section 1, Chapter 2, “GNSS RNAV”.

3.2.4 Obstacle clearance

The minimum obstacle clearance in the primary area is 75 m (246 ft).

3.2.5 Descent gradient

The general criteria of Part I, Section 4, Chapter 5, 5.3, “Descent gradient”, apply.

3.3 INITIAL AND INTERMEDIATE MISSED APPROACH SEGMENT

General criteria apply as modified by this paragraph.

3.3.1 Missed approach point (MAPt)

The missed approach point (MAPt) shall be defined by a flyover waypoint.

3.3.2 Location of MAPt

For a runway-aligned approach, the missed approach point shall be located at or before the threshold. Where the final segment is not aligned with the runway centre line, the optimum location is the intersection of the final approach course and the extended runway centre line. (See Figure III-3-3-1.) Where necessary, the MAPt may be moved away from the threshold towards the FAF provided that the OCA/H is not lower than the altitude/height at the MAPt on a nominal 5.2 per cent (3°) descent gradient or the promulgated descent gradient if steeper. An increase in OCA/H may be required to meet this condition.

3.3.3 Missed approach area length

Minimum segment length distances between the MAPt and the MATF or the MAHF are contained in Table III-2-1-4 or III-2-1-10.

3.3.4 Missed approach area width

3.3.4.1 The earliest missed approach point (MAPt) is determined by the value of ATT at the MAPt. For ATT values, see Section 1, Chapter 2, 2.2 for GNSS.

3.3.4.2 From this point the area splays at 15° on each side of the missed approach track until it reaches the width of the area at the earliest MATF (primary area plus secondary areas). See Figures III-3-3-2 and III-3-3-3.

3.3.5 Missed approach area width for SBAS

3.3.5.1 *Straight missed approach*

For the straight segment from the MAPt to the earliest turning point of a turning missed approach, the system remains in NPA mode. Therefore the area semi-width is equal to 1.76 km (0.95 NM) and along track tolerance is ± 0.44 km (0.24 NM) up to the turn initiation point. The principle of secondary area applies. See Figure III-3-3-4.

3.3.5.2 *Turning missed approach*

At the earliest turning point of a turning missed approach the system reverts to terminal mode. Therefore, for the succeeding segment, the area semi-width is equal to 3.7 km (2.0 NM) [helicopter 3.42 km (1.85 NM)] up to 15 NM from the ARP and 4.63 km (2.5 NM) [helicopter 4.07 km (2.20 NM)] up to 30 NM from the ARP.

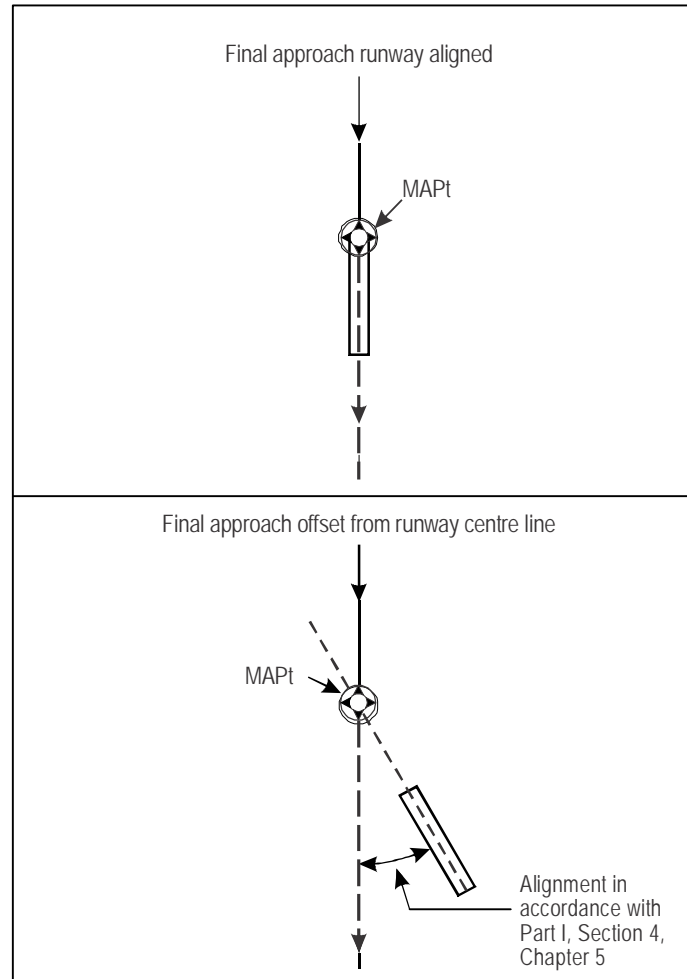

Figure III-3-3-1. Location of MAPt

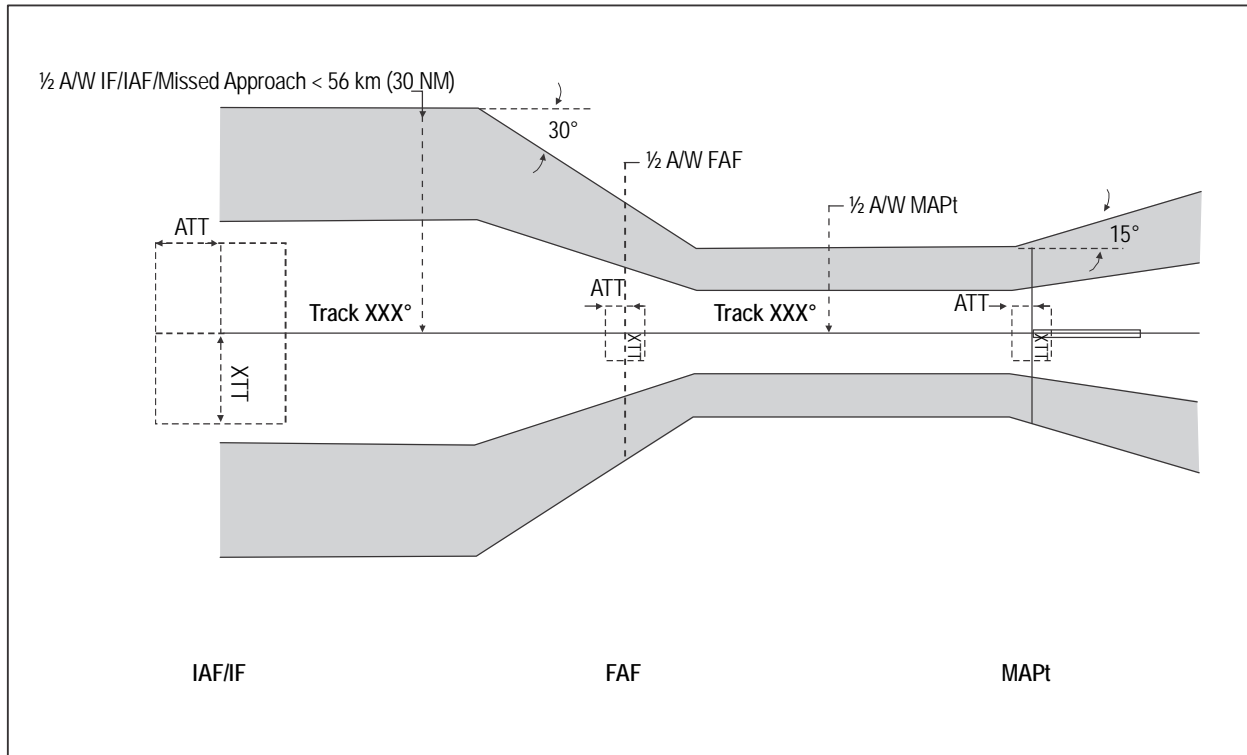

Figure III-3-3-2. RNP APCH areas

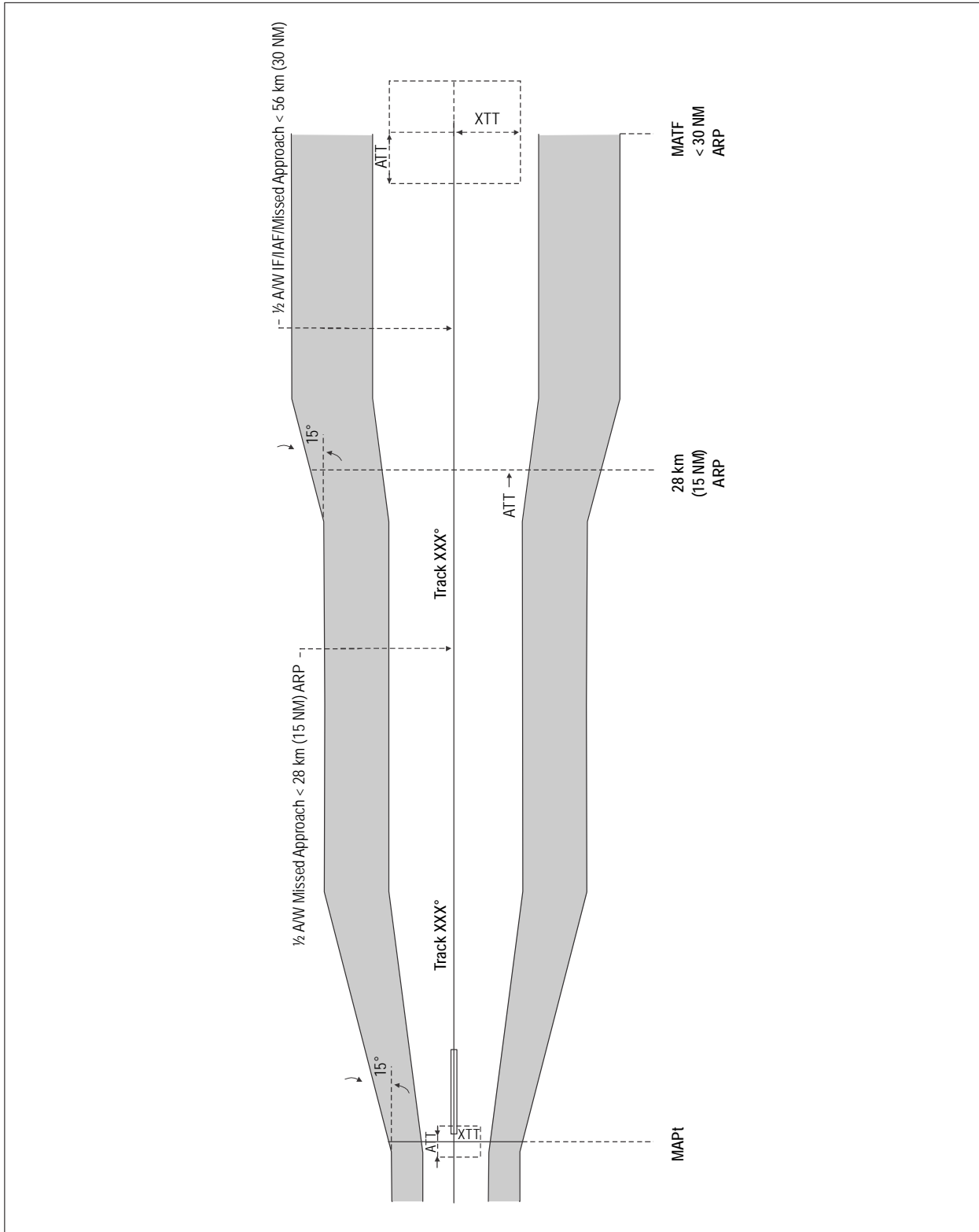

Figure III-3-3-3. RNP APCH missed approach areas

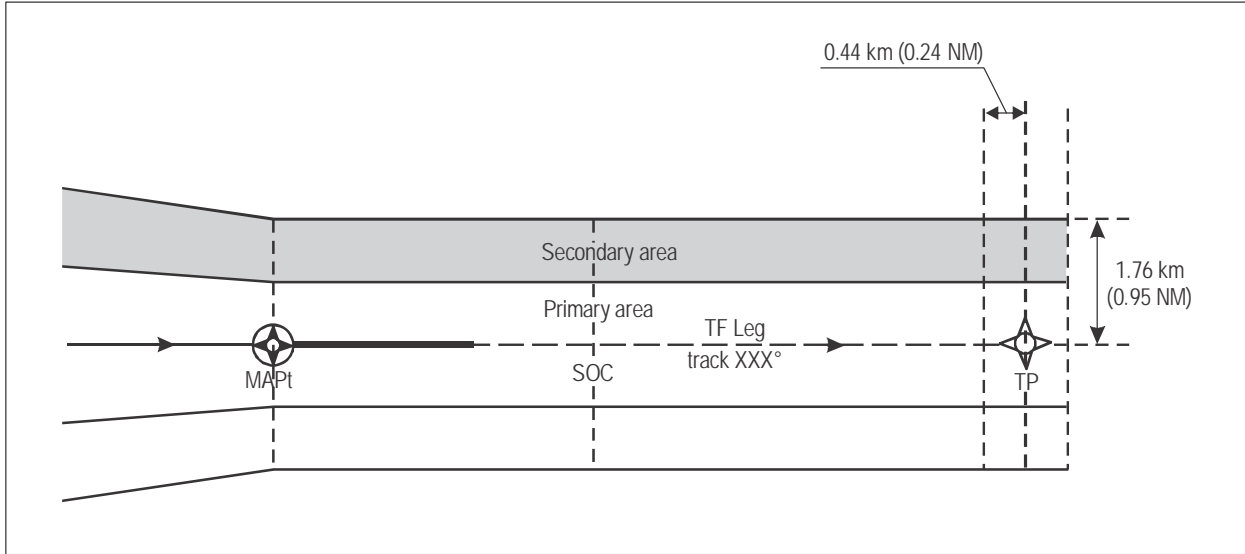

Figure III-3-3-4. Straight missed approach segment for SBAS

Chapter 4

APV/BAROMETRIC VERTICAL NAVIGATION (BARO-VNAV)

Note 1.— This chapter is based on, and applicable for, aircraft meeting the APV/Baro-VNAV criteria as laid down in the Performance-based Navigation (PBN) Manual, Volume II, Attachment A (Doc 9613).

Note 2.— In this chapter, distances and heights related to obstacle clearance surfaces are all in SI units. Distances and heights are measured relative to threshold (positive before/above threshold, negative after/below threshold). If non-SI units are required, the appropriate conversions must be made.

4.1 GENERAL

4.1.1 This chapter describes the vertical component of the APV/Baro-VNAV procedure criteria. The general criteria and Sections 1, 2 and 3, as amplified or modified by criteria in this chapter, apply.

4.1.2 Baro-VNAV approach procedures are classified as APV procedures in support of Type A 3D approach operations. They utilize a DA/H and not an MDA/H, and neither a FAF nor a missed approach point (MAPt) is identified. They use obstacle assessment surfaces similar to those for ILS, but based on the specific lateral guidance system.

4.1.3 Baro-VNAV procedures are used in association with LNAV-only procedures. The LNAV-only FAF and MAPt are needed to define the lateral areas and to support the lateral guidance but they are not used for the vertical navigation function.

Note.— The criteria associated with the lateral navigation performance (LNAV) are based on the RNP APCH criteria detailed in Chapter 3.

4.1.4 Baro-VNAV procedures shall not be authorized with a remote altimeter setting.

Note.— A remote altimeter-setting source may be charted for the associated LNAV-only procedure.

4.2 STANDARD CONDITIONS

4.2.1 Vertical path angle (VPA)

4.2.1.1 The effective VPA will differ from the promulgated VPA as it is dependent upon temperature and aerodrome elevation. The optimum VPA is 3°. The promulgated VPA shall be such that the effective VPA throughout the year is as close as possible to 3.0° for the given aerodrome elevation and prevailing temperatures. See Table III-3-4-1 to determine the optimum promulgated VPA. The following conditions apply:

- the effective VPA at the lowest prevailing temperature shall remain greater than or equal to 2.5°;
- the effective VPA at the highest prevailing temperature should remain less than or equal to 3.5°.

4.2.1.3 A procedure shall not have a promulgated VPA that is less than 2.5°. A procedure with a promulgated VPA that exceeds 3.5° is a non-standard procedure. It shall be subject to an aeronautical study and will require special approval by the national competent authority (see Part I, Section 4, Chapter 5, 5.3.1.2 and Appendix B to Chapter 5).

Table III-3-4-1. Effective vs promulgated VPA as a function of aerodrome elevation and temperature (Green = optimum; Yellow = non-standard; Orange = prohibited)

Temp (C°)	Promulgated VPA 2.8°			Promulgated VPA 3.0°			Promulgated VPA 3.2°		
	Aerodrome elevation			Aerodrome elevation			Aerodrome elevation		
	MSL	3 000 ft	6 000 ft	MSL	3 000 ft	6 000 ft	MSL	3 000 ft	6 000 ft
50	3.14	3.21	3.28	3.37	3.44	3.51	3.59	3.67	3.75
40	3.05	3.11	3.18	3.26	3.33	3.40	3.48	3.55	3.63
30	2.95	3.01	3.07	3.16	3.22	3.29	3.37	3.44	3.51
20	2.85	2.91	2.97	3.05	3.12	3.18	3.26	3.32	3.40
10	2.75	2.81	2.87	2.95	3.01	3.07	3.14	3.21	3.28
0	2.65	2.71	2.77	2.84	2.90	2.96	3.03	3.10	3.16
-10	2.55	2.61	2.66	2.74	2.79	2.85	2.92	2.98	3.04
-20	2.46	2.51	2.56	2.63	2.69	2.74	2.81	2.87	2.93
-30	2.36	2.41	2.46	2.53	2.58	2.63	2.70	2.75	2.81
-40	2.26	2.31	2.36	2.42	2.47	2.53	2.58	2.64	2.70
-50	2.16	2.21	2.26	2.32	2.36	2.42	2.47	2.52	2.58

4.2.2 The reference datum height should be 15 m (50 ft).

4.2.3 All obstacle heights shall be referenced to threshold elevation.

4.3 APV SEGMENT

4.3.1 General

The APV segment for the Baro-VNAV approach contains the final descent segment for landing and the initial and intermediate segments of the missed approach. It should be aligned with the extended runway centre line. Where it is physically impracticable to align the final approach segment with the runway centre line, see 4.6. A turn at the FAF of up to 15 degrees is allowed.

4.3.2 APV OAS

The APV OAS starts at the final approach point (FAP), which is located at the intersection of the vertical path and the procedure altitude specified for the preceding segment in ISA conditions. The FAP should not be located more than 19 km (10 NM) before the threshold. The APV OAS ends at the MAHF, MATF or the turn altitude, whichever comes first. The LNAV missed approach criteria apply after the end of the APV OAS. The LNAV FAF and MAPt are used to define the geometry of the areas and surfaces, to define any underlying LNAV procedure and for database coding purposes.

4.3.3 Frame of reference

See Chapter 6, 6.4.8.2, “Frame of reference”.

4.3.4 Definition of the OAS

4.3.4.1 The OAS is used to identify accountable obstacles and consists of the following surfaces:

- a) final approach surface (FAS);
- b) ground plane; and
- c) missed approach surface (Z surface).

The final approach surface is bounded laterally by the edges of the LNAV primary area. Each surface has associated side surfaces. The upper/outer edges of the APV-OAS side surfaces are laterally coincident with the outer edges of the LNAV secondary areas. The lower/inner edges of the APV-OAS side surfaces are laterally coincident with the edges of the LNAV primary area (see Figures III-3-4-1 and III-3-4-2).

4.3.4.2 *Final approach surface.* The origin of the final approach surface (FAS) is at threshold level and is located at a distance of 444 m (ATT) prior to the point where the promulgated vertical path reaches a specified height above the threshold. This height, H_i , is an altitude dependent value throughout the final approach segment (see below). The final approach surface extends up to the intersection with the horizontal OCS of the intermediate segment. This intersection may occur before or after the FAP. When this intersection is after the FAP, the OCS of the intermediate segment continues within the final approach segment and becomes the final approach OCS up to the point where it intersects the final approach surface.

The value of H_i is as follows:

- a) H_0 = 75 m below 5 000' AMSL;
- b) $H_{5\,000}$ = 105 m between 5 000' and 10 000' AMSL; and

- c) $H_{10\,000} = 120$ m at or above 10 000' AMSL.

For detailed rules of the application of H_i see paragraphs 4.3.4.2.4 and 4.3.4.2.5, and Figure III-3-4-4.

4.3.4.2.1 The determination of the VPA may require an iterative process. Initially, a VPA is selected based upon paragraph 4.2.1. The design is carried out and the OCA/H is calculated using this VPA and the minimum useable temperature is determined. If the result is satisfactory, the VPA, OCA/H and minimum temperature are promulgated. If not, then the VPA and the minimum temperature are adjusted until an optimum solution is found.

4.3.4.2.2 *Determination of minimum promulgated temperature.* The minimum promulgated temperature depends upon the minimum VPA (the temperature correction is obtained from Appendix A to this chapter) as follows:

- a) The minimum VPA for the proposed minimum promulgated temperature shall be calculated. If the minimum VPA is less than 2.5° , either the promulgated VPA shall be increased to ensure the minimum VPA is equal to or greater than 2.5° , or the minimum promulgated temperature for the procedure shall be increased; and
- b) The length of the preceding segment shall be reviewed to ensure it meets the relevant requirements for minimum distance before vertical path intercept.

Note 1.— The minimum temperature to be promulgated is an optimum balance between runway availability due to weather (visibility and cloud ceiling) and cold temperature.

Note 2.— No minimum temperature restrictions apply to aircraft with avionics incorporating approved final approach temperature compensation, provided the minimum temperature is not below that for which the equipment is certificated, or to SBAS avionics approved to fly Baro-VNAV procedures.

4.3.4.2.3 *Final approach side surfaces.* The lower/inner edges of the final approach side surfaces are defined by the edges of the FAS. The outer edges of the final approach side surfaces are defined by the edges of the LNAV secondary area at H_i above the FAS.

4.3.4.2.4 *Approach surfaces above 5 000 ft* (see Figure III-3-4-4). When the horizontal OCS of the intermediate segment is above 5 000 ft AMSL, the FAS above 5 000 ft is replaced by a revised final approach surface, FAS', between 5 000 ft and 10 000 ft and by a revised final approach surface, FAS'', above 10 000 ft. The surfaces FAS'', FAS' and FAS are connected by horizontal planes at 10 000 ft and 5 000 ft, respectively.

$X_{FAS'}$ and $\tan\alpha_{FAS'}$ are calculated according to the formula in paragraph 4.3.4.2.5 and applying a $H_{5\,000}$ of 105 m.

$X_{FAS''}$ and $\tan\alpha_{FAS''}$ are calculated according to the formula in paragraph 4.3.4.2.5 and applying a $H_{10\,000}$ of 120 m.

The outer edges of the final approach side surfaces associated with FAS' are defined by the edges of the LNAV secondary areas at 105 m above FAS'. The outer edges of the final approach side surfaces associated with FAS'' are defined by the edges of the LNAV secondary areas at 120 m above FAS''.

The outer edges of the side surfaces associated with the horizontal planes connecting FAS'', FAS' and FAS are reduced from 120 m to 105 m and from 105 m to 75 m, respectively. This results in twisted side surfaces associated with the horizontal planes.

4.3.4.2.5 *Calculation of FAS angle, FAS origin and FAS height.*

The angle of the FAS (α_{FAS}) shall be determined as follows:

$$\tan \alpha_{FAS} = (\text{height at FAP} - \Delta h - H_i) * \tan \text{VPA} / (\text{height at FAP} - H_i)$$

(see Appendix A and Figure III-3-4-3)

The origin of the FAS at threshold level shall be determined as follows:

$$X_{\text{FAS}} = [(H_i - \text{RDH}) / \tan \text{VPA}] + \text{ATT}$$

The height of the FAS (h_{FAS}) at range x relative to threshold shall be determined as follows:

$$h_{\text{FAS}} = (x - X_{\text{FAS}}) * \tan \alpha_{\text{FAS}} \text{ up to } 5\,000 \text{ ft or intermediate segment OCS, whichever is smaller.}$$

4.3.4.2.6 *FAS elevation above 5 000 ft and 10 000 ft.* Where the calculation of h_{FAS} results in an FAS elevation above 5 000 ft AMSL then, from that x coordinate onwards, H_0 of 75 m shall be replaced by $H_{5\,000}$ of 105 m. In such a case, $\tan \alpha_{\text{FAS}}$, X_{FAS} , and h_{FAS} shall be recalculated by applying 105 m ($H_{5\,000}$). If h_{FAS} results in a FAS' elevation below 5 000 ft AMSL, then the FAS' elevation is set at 5 000 ft AMSL at x . If h_{FAS} results in a FAS' elevation above 5 000 ft (but below 10 000 ft AMSL), then h_{FAS} is the FAS' elevation at x (see 4.3.4.2.4 and Figure III-3-4-4). A similar recalculation shall be carried out if the application of 105 m ($H_{5\,000}$) results in a FAS'' elevation above 10 000 ft.

4.3.4.3 *Ground plane.* The ground plane is defined by a surface at threshold level bounded by the LNAV primary area between the origin of the FAS (see 4.3.4.2.5) and the origin of the missed approach Z surface (X_z). The lower/inner edges of the ground plane side surfaces are defined by the edges of the LNAV primary area at threshold level. The upper/outer edges of the side surfaces are defined by the outer edges of the LNAV secondary areas at the height of H_i above threshold at the origin of X_{FAS} and the outer edges of the LNAV area, reducing to 30 m above threshold at ATT before threshold and continuing at 30 m above threshold up to X_z .

4.3.4.4 *Missed approach (Z) surface*

4.3.4.4.1 The origin of the missed approach surface (X_z) is at threshold level between -900 and -1 400 m relative to threshold. It has a nominal gradient of 2.5 per cent. If an operational benefit can be realized by promulgating missed approach climb gradients greater than the nominal 2.5 per cent, the Z surface and associated side surfaces may be adjusted for higher gradients. If an OCA/H for a missed approach gradient higher than 2.5 per cent is published, the OCA/H for a missed approach gradient of 2.5 per cent shall also be published. The Z surface is bounded laterally by the LNAV primary area. The lower/inner edges of the associated side surfaces are defined by the edges of the LNAV missed approach primary area and the outer edges of the LNAV secondary areas 30 m above the missed approach (Z) surface.

4.3.4.4.2 The origin of the Z surface depends upon the category of aircraft as follows:

- a) CAT A and B: $X_z = -900 \text{ m}$
- b) CAT C: $X_z = -1\,100 \text{ m}$
- c) CAT D: $X_z = -1\,400 \text{ m}$

4.3.4.4.3 For an airfield elevation higher than 900 m (2 953 ft) or a promulgated VPA above 3.2°, the origin of the Z surface (X_z) shall be determined by applying the following formula:

$$X_z = \min [\text{Value tabulated in 4.3.4.4.2, } (HL - \text{RDH}) / \tan \text{VPA} - (\text{ATT} + 2 * \text{TAS} * \sin \text{VPA} / \gamma * (\text{TAS} + V_w))]]$$

Where:

HL = height loss

VPA = promulgated VPA

- TAS = Maximum true airspeed based on the highest final approach speed for each aircraft category (see Tables I-4-1-1 and I-4-1-2) at the aerodrome elevation with a temperature of ISA + 15°C.
- γ = vertical deceleration [0.08g (2.56 ft/sec²)]
- V_w = 10 kt

4.3.5 Termination of the APV segment

The APV segment terminates at the earliest MAPt if a turn is specified at the MAPt, at the earliest MATF or the K-K line for a turn at an altitude, or the MAHF, whichever is earliest. In any case the earliest turning point shall not be before the SOC. In case of a turn at the MAPt, the lowest possible OCH is the height loss above the height of the VPA' plane (see paragraph 4.4.1) at the earliest MAPt.

4.4 DETERMINATION OF OCH FOR THE APV SEGMENT

4.4.1 Categorization of obstacles

4.4.1.1 Accountable obstacles are divided into approach and missed approach obstacles. The standard method of categorization is as follows:

- a) approach obstacles are those located between the beginning of the final approach segment and the origin of the Z surface; and
- b) missed approach obstacles are those located in the remainder of the missed approach segment (see Figure III-3-4-5 a)).

4.4.1.2

- a) Obstacles located before the origin of the Z surface penetrating a final approach surface or the ground plane may be considered as missed approach obstacles if they penetrate a surface VPA', parallel to the promulgated VPA and with origin at Xz, i.e. obstacle height greater than $[(x-Xz) \tan VPA]$ (see Figure III-3-4-5 b));
- b) Obstacles located before the origin of the Z surface penetrating a FAS side surface or the ground side surface may be considered as missed approach obstacles if they penetrate a VPA' side surface defined as follows at the along-track distance of the obstacle (see Figure III-3-4-6):
 - Inner edge: edge of the LNAV primary area at VPA' height;
 - Outer edge: outer edge of the LNAV secondary area 30 m higher than VPA' height.

4.4.2 Approach obstacles

4.4.2.1 For final approach obstacles penetrating the FAS or the ground plane, the final approach OCH shall be determined by adding the category-related height loss margin to the height of the obstacle (see 4.5).

4.4.2.2 For final approach obstacles penetrating the final approach side surface or the side surface associated with the ground plane, the final approach OCH shall be determined by adding a value, reduced linearly from the full height loss value at the inner edge of the side surface to zero at the outer edge of the side surface, to the height of the obstacle.

4.4.3 Missed approach obstacles

4.4.3.1 For missed approach obstacles penetrating a final approach surface, the ground plane or the Z surface, the height of the equivalent approach obstacle shall be calculated using the following formula:

$$h_a = \frac{h_{ma} * \cot Z + (X - X_z)}{[\cot Z + \cot \theta]}$$

where:

- h_a = height of the equivalent approach obstacle
- h_{ma} = height of the missed approach obstacle
- $\cot Z$ = cotangent of the Z surface angle
- $\cot \theta$ = cotangent of the VPA
- X_z = X coordinate of the intermediate missed approach surface (Z)
- X = obstacle distance from threshold (positive before, negative after)

4.4.3.2 For missed approach obstacles penetrating a VPA' side surface or a missed approach side surface, the height of the equivalent approach obstacle shall be calculated using the following formula:

$$h_a = \frac{h'_{ma} * \cot Z + (X - X_z)}{[\cot Z + \cot \theta]}$$

where h'_{ma} is the amount of the penetration of the side surface plus the height of the inner edge of the side surface at the along-track distance of the penetrating obstacle (see Figure III-3-4-6).

4.4.3.3 The missed approach OCH is determined by adding the applicable height loss to the highest equivalent obstacle height, h_a , calculated according to 4.4.3.1 and 4.4.3.2.

4.4.4 Obstacle clearance height

The OCH of the approach is the maximum value of the final approach OCH and the missed approach OCH determined according to 4.4.2 and 4.4.3.

4.5 HEIGHT LOSS MARGINS

4.5.1 The height loss margins using a barometric altimeter shall be applied to all approach and equivalent approach obstacles. They are detailed in Table III-3-4-2.

Table III-3-4-2. Height loss margins

<i>Aircraft category (V_{at})</i>	<i>Margin using radio altimeter¹</i>		<i>Margin using barometric altimeter</i>	
	<i>Metres</i>	<i>Feet</i>	<i>Metres</i>	<i>Feet</i>
A – 169 km/h (90 kt)	13	42	40	130
B – 223 km/h (120 kt)	18	59	43	142
C – 260 km/h (140 kt)	22	71	46	150
D – 306 km/h (165 kt)	26	85	49	161

1. The radio altimeter margins are reproduced for the corrections to steep angles and high airports only and not for the derivation of the OCH.

4.5.2 Adjustments for high airfield elevations and steep angles

4.5.2.1 *High airfield elevations.* The values in Table III-3-4-2 shall be adjusted for airfield elevations higher than 900 m (2 953 ft). The tabulated allowances shall be increased by 2 per cent of the radio altimeter margin per 300 m (984 ft) airfield elevation.

4.5.2.2 *Steep angle approaches.* In exceptional cases, for approach angles greater than 3.2°, the allowances shall be increased by 5 per cent of the radio altimeter margin per 0.1° increase in glide path angle between 3.2° and 3.5°.

4.5.3 Adjustment for aircraft with non-standard height loss values

The values in Table III-3-4-2 are calculated to account for aircraft using normal manual overshoot procedures from OCA/H on the nominal approach path. Values in the table may be adjusted for specific aircraft types where adequate flight and theoretical evidence is available, i.e. the height loss value corresponding to a probability of 1×10^{-5} (based on a missed approach rate 10^{-2}).

4.5.4 Margins for specific V_{at}

If a height loss/altimeter margin is required for a specific V_{at} , the following formulae shall apply (see also Table II-1-1-4):

$$\text{Margin} = (0.068 V_{at} + 28.3) \text{ metres where } V_{at} \text{ in km/h}$$

$$\text{Margin} = (0.125 V_{at} + 28.3) \text{ metres where } V_{at} \text{ in kt}$$

where V_{at} is the speed at threshold based on 1.3 times stall speed in the landing configuration at maximum certificated landing mass.

Note.— The equations assume the aerodynamic and dynamic characteristics of the aircraft are directly related to the speed category. Thus, the calculated height loss/altimeter margins may not realistically represent small aircraft with V_{at} at maximum landing mass exceeding 165 kt.

4.6 BARO-VNAV APPROACH WITH OFFSET FINAL APPROACH TRACK ALIGNMENT

4.6.1 Use of Baro-VNAV approach with offset alignment

4.6.1.1 In certain cases, it may not be physically practicable to align the final approach segment with the runway centreline because of obstacle problems. An offset final approach track shall not be established as a noise abatement measure.

The final approach track shall intersect the runway extended centreline:

- a) at an angle not exceeding 15 degrees; and
- b) at a distance D before threshold providing at least a minimum stabilization distance (MSD) before the point where the promulgated VPA reaches a height of 75 m (246 ft) above threshold elevation (see Figure III-3-4-7).

4.6.1.2 The minimum stabilization distance (MSD) is the sum of L1 and L2, where:

L1 is the distance between the intercept point and the end of the turn

L2 is a 3-second delay to take into account the roll-out distance

$$L1 = r \times \tan(\theta/2)$$

$$L2 = 3 \times V/3600$$

r = turn radius calculated with a 15° bank angle and the TAS (at aerodrome elevation) corresponding to the final approach IAS + 19 km/h (10 kt)

θ = turn angle

In the above equations, if distances and turn radii are in NM, V is in kt; or if distances and turn radii are in km, V is in km/h.

4.6.1.3 The general arrangement is shown in Figure III-3-4-7.

4.6.2 Obstacle clearance criteria

The provisions contained in 4.1 to 4.6 apply except that:

- a) all the obstacle clearance surfaces and calculations are based on a fictitious runway aligned with the final approach track. This fictitious runway has the same landing threshold elevation as a real one;
- b) the OCA/H for this procedure shall be at least equal to the altitude/height of the promulgated VPA at the intercept point plus $MSD \times \tan VPA$ (see Figure III-3-4-7).

4.7 PROMULGATION

4.7.1 The general criteria in Part I, Section 4, Chapter 9, 9.5, “Procedure naming for arrival and approach charts” apply. The instrument approach chart shall be entitled “RNAV(GNSS) or RNP Rwy XX” in accordance with Part III, Section 5, Chapter 1. The minimum box on the chart shall include OCA/H values for NPA (LNAV) and APV/Baro-VNAV (LNAV/VNAV) operations.

4.7.2 OCA/H shall be published in accordance with Part I, Section 4, Chapter 5, 5.5, “Promulgation”.

4.7.3 In addition, the following shall be promulgated:

- a) RDH;
- b) VPA (degrees and hundredths of a degree for databases/degrees and tenths of a degree for charting);
- c) the minimum temperature for which APV/Baro-VNAV operations are authorized;
- d) the temperature above which the effective VPA will exceed 3.5°; and
- e) for database coding purposes only, the LNAV, FAF and MAPt.

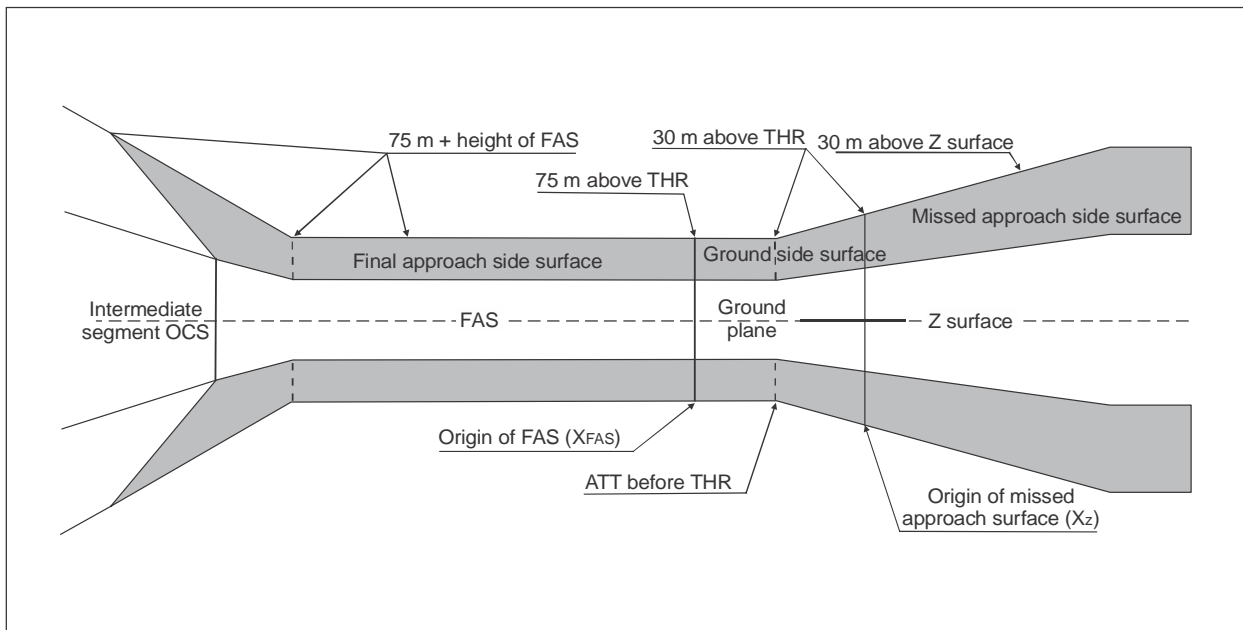
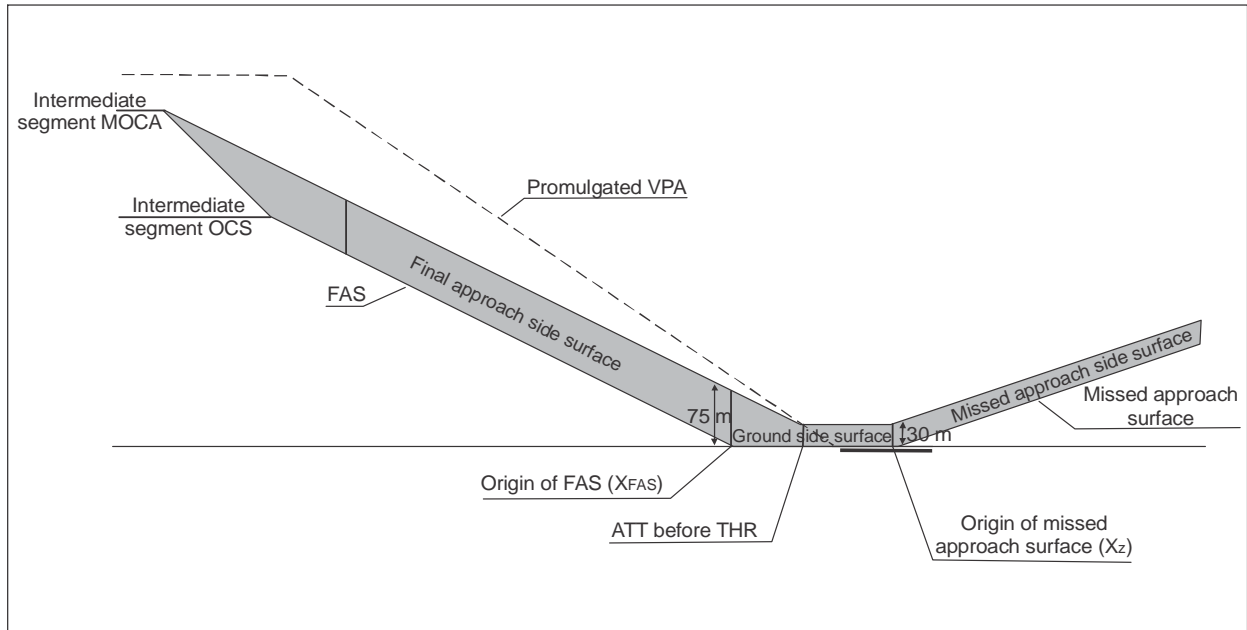

Figure III-3-4-1. APV/Baro-VNAV area — APV OAS in plan view (aerodrome and intermediate segment OCS at or below 5 000 ft)



**Figure III-3-4-2. Baro-VNAV OAS — Profile view
(aerodrome and intermediate segment OCS at or below 5 000 ft)**

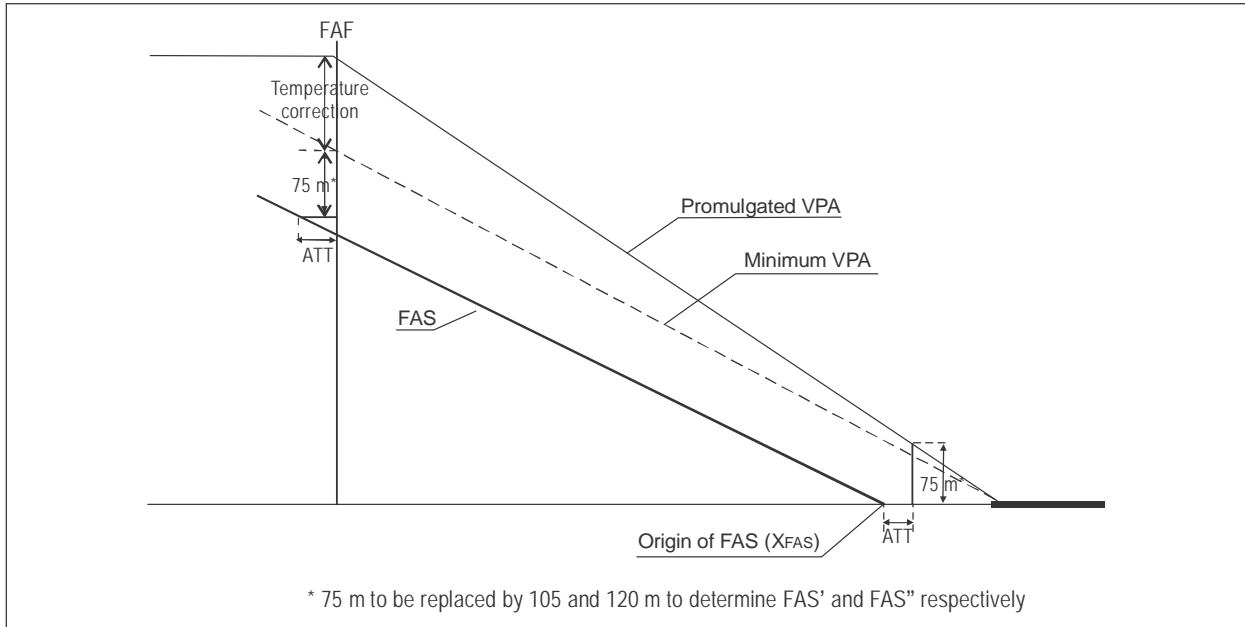

Figure III-3-4-3. VNAV final approach surface and minimum VPA

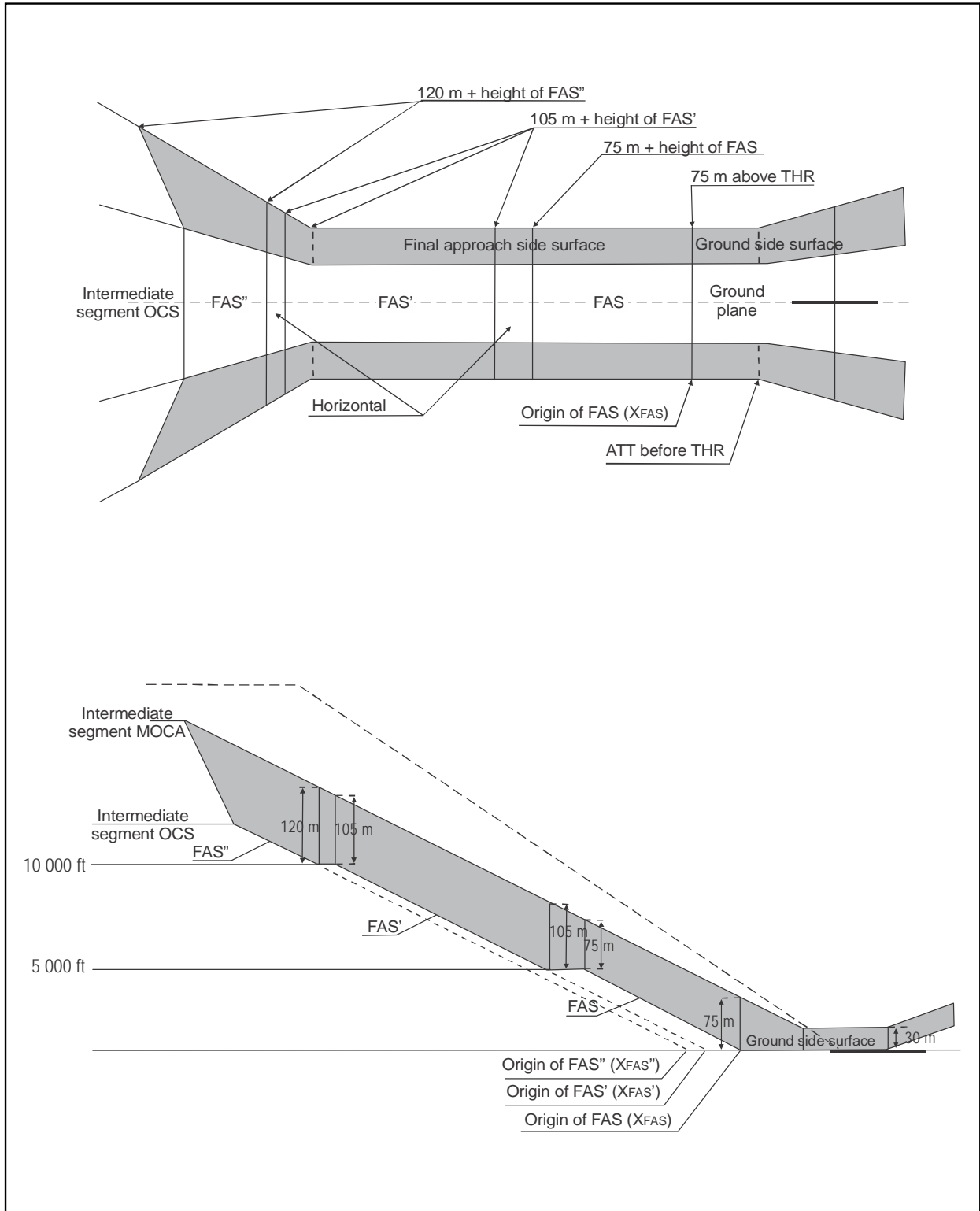

Figure III-3-4-4. Final approach surfaces above 5 000 ft

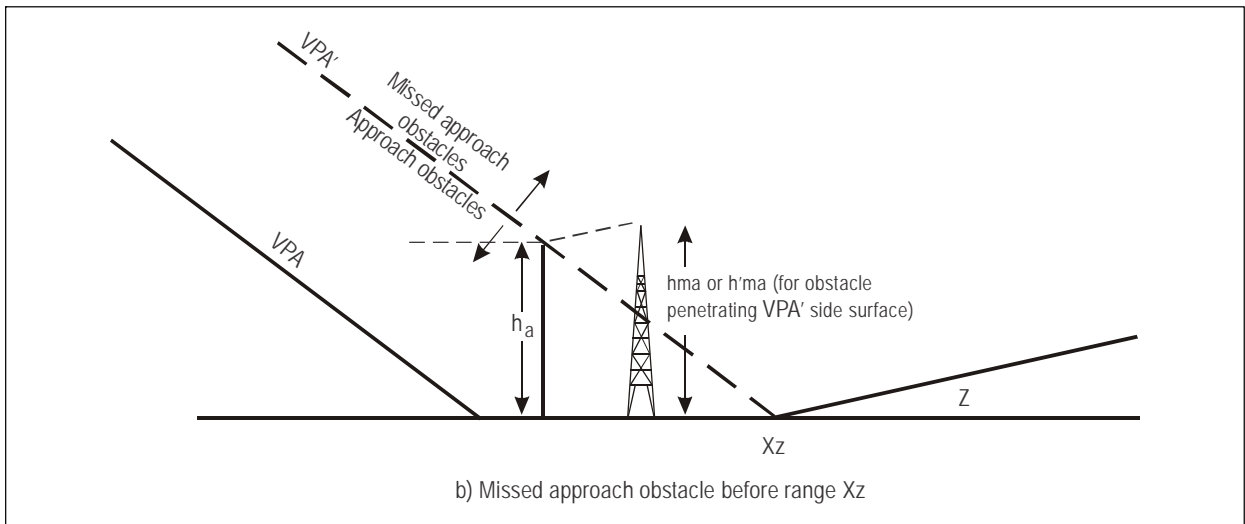
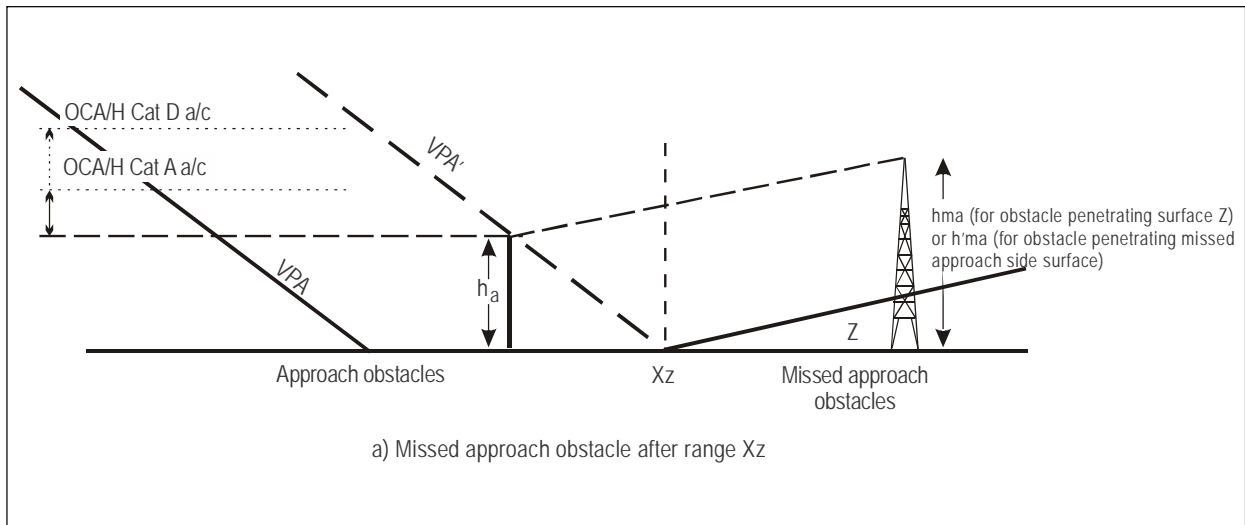

Figure III-3-4-5 a) and b). Missed approach obstacles

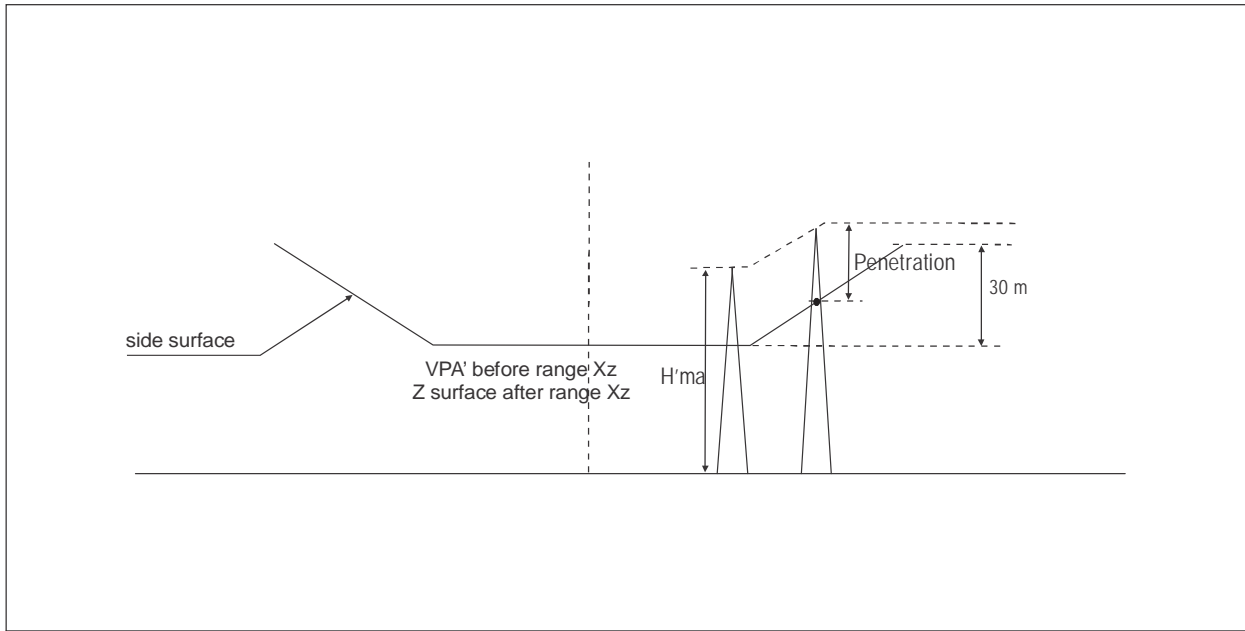

Figure III-3-4-6. Missed approach side surface penetration

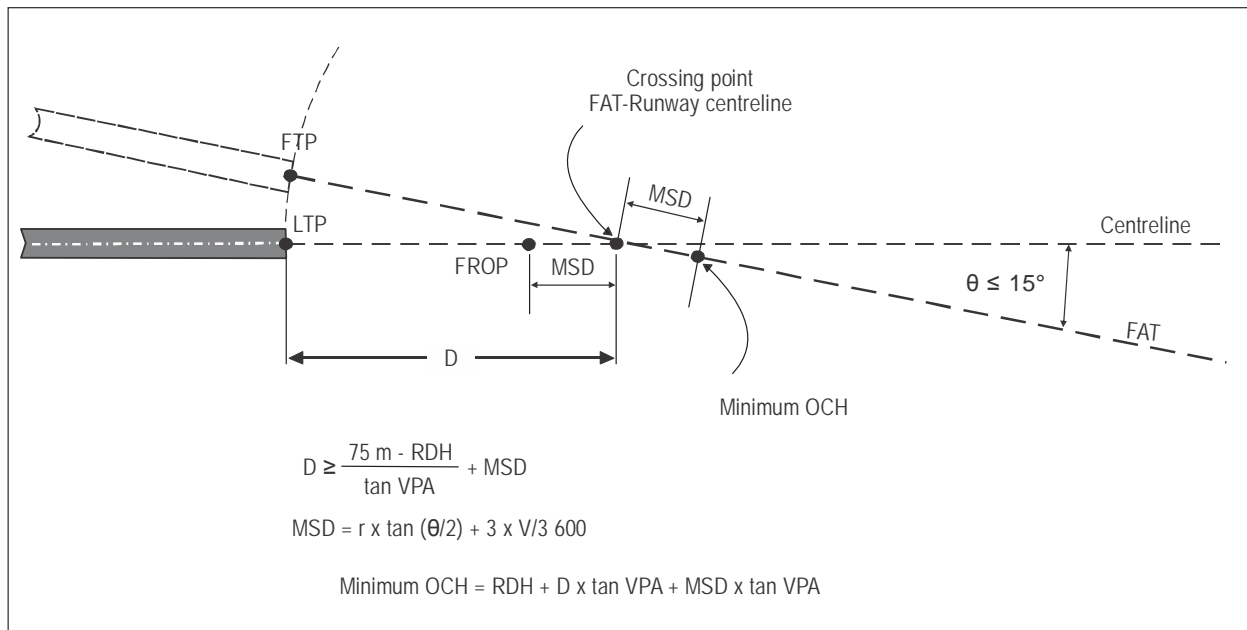

Figure III-3-4-7. Baro-VNAV with offset final approach track alignment

Appendix A to Chapter 4

TEMPERATURE CORRECTION

1.1 REQUIREMENT FOR TEMPERATURE CORRECTION

The calculated minimum safe altitudes/heights must be adjusted when the ambient temperature on the surface is much lower than that predicted by the standard atmosphere.

1.2 TABULATED CORRECTIONS

For FAS angle calculation the cold temperature correction should be obtained from Tables III-3-4-App A-1 to III-3-4-App A-6 (see paragraph 3).

1.3 CALCULATION OF CORRECTIONS

To calculate the temperature correction (Δh) to determine the FAS angle and effective VPA apply the following formula:

$$\Delta h = (-\Delta T_{STD}/L_o)\ln[1+L_o h_{FAP}/(T_o+L_o h_{THR})]$$

where:

- ΔT_{STD} = temperature deviation from the standard day (ISA) temperature
- L_o = standard temperature lapse rate with pressure altitude in the first layer (sea level to tropopause) of the ISA (-0.0065°/m)
- h_{FAP} = procedure height above the threshold at the FAP
- T_o = standard temperature at sea level (288.15K)
- h_{THR} = threshold elevation above mean sea level

Note.— The formula to calculate the temperature correction is based on Equation 24 from Engineering Science Data Unit Publication, Performance, Volume 2, Item Number 770221, which assumes an off-Standard atmosphere. For verification purposes, the Tables III-3-4-App A-1 to III-3-4-App A-3 can be used.

1.4 ASSUMPTION REGARDING TEMPERATURE LAPSE RATES

The above equation assumes a constant “off-standard” temperature lapse rate. The actual lapse rate may vary considerably from the assumed standard, depending on latitude and time of year. However, the corrections derived from the calculation method are valid up to 11 000 m (36 000 ft).

Table III-3-4-App A-1. Temperature correction to be used in calculating the FAS angle and effective VPA (m) (SI)

<i>Aerodrome temperature (°C)</i>	<i>Height of FAP above threshold at sea level (m)</i>								
	<i>300</i>	<i>450</i>	<i>600</i>	<i>750</i>	<i>900</i>	<i>1 050</i>	<i>1 200</i>	<i>1 350</i>	<i>1 500</i>
50	-37	-55	-73	-92	-110	-129	-148	-167	-185
40	-26	-39	-52	-66	-79	-92	-106	-119	-132
30	-16	-24	-31	-39	-47	-55	-63	-71	-79
20	-5	-8	-10	-13	-16	-18	-21	-24	-26
10	5	8	10	13	16	18	21	24	26
0	16	24	31	39	47	55	63	71	79
-10	26	39	52	66	79	92	106	119	132
-20	37	55	73	92	110	129	148	167	185
-30	47	71	94	118	142	166	190	214	238
-40	57	86	115	144	174	203	232	262	291
-50	68	102	136	171	205	240	274	309	344

Table III-3-4-App A-2. Temperature correction to be used in calculating the FAS angle and effective VPA (m) (SI)

<i>Aerodrome temperature (°C)</i>	<i>Height of FAP above threshold at 900 m AMSL (m)</i>								
	<i>300</i>	<i>450</i>	<i>600</i>	<i>750</i>	<i>900</i>	<i>1 050</i>	<i>1 200</i>	<i>1 350</i>	<i>1 500</i>
50	-44	-65	-87	-109	-132	-154	-176	-198	-221
40	-33	-49	-66	-83	-99	-116	-133	-150	-167
30	-22	-33	-45	-56	-67	-79	-90	-101	-113
20	-12	-17	-23	-29	-35	-41	-47	-53	-59
10	-1	-1	-2	-2	-3	-3	-4	-4	-5
0	10	15	20	25	29	34	39	44	49
-10	20	31	41	51	62	72	83	93	104
-20	31	47	62	78	94	110	126	142	158
-30	42	63	84	105	126	147	169	190	212
-40	52	79	105	132	158	185	212	239	266
-50	63	95	127	159	191	223	255	287	320

Table III-3-4-App A-3. Temperature correction to be used in calculating the FAS angle and effective VPA (m) (SI)

<i>Aerodrome temperature (°C)</i>	<i>Height of FAP above threshold at 1 800 m AMSL (m)</i>								
	<i>300</i>	<i>450</i>	<i>600</i>	<i>750</i>	<i>900</i>	<i>1 050</i>	<i>1 200</i>	<i>1 350</i>	<i>1 500</i>
50	-51	-76	-102	-128	-154	-180	-206	-232	-258
40	-40	-60	-80	-100	-121	-141	-162	-182	-203
30	-29	-44	-58	-73	-88	-103	-118	-132	-147
20	-18	-27	-37	-46	-55	-64	-74	-83	-92
10	-7	-11	-15	-18	-22	-26	-30	-33	-37
0	4	5	7	9	11	13	15	16	18
-10	14	22	29	36	44	51	59	66	73
-20	25	38	51	64	77	90	103	116	129
-30	36	54	73	91	110	128	147	165	184
-40	47	71	95	119	142	167	191	215	239
-50	58	87	117	146	175	205	235	265	294

Table III-3-4-App A-4. Temperature correction to be used in calculating the FAS angle and effective VPA (ft) (Non-SI)

<i>Aerodrome temperature (°C)</i>	<i>Height of FAP above threshold at sea level (ft)</i>								
	<i>1 000</i>	<i>1 500</i>	<i>2 000</i>	<i>2 500</i>	<i>3 000</i>	<i>3 500</i>	<i>4 000</i>	<i>4 500</i>	<i>5 000</i>
50	-122	-183	-245	-306	-368	-430	-493	-555	-618
40	-87	-131	-175	-219	-263	-307	-352	-397	-441
30	-52	-78	-105	-131	-158	-184	-211	-238	-265
20	-17	-26	-35	-44	-53	-61	-70	-79	-88
10	17	26	35	44	53	61	70	79	88
0	52	78	105	131	158	184	211	238	265
-10	87	131	175	219	263	307	352	397	441
-20	122	183	245	306	368	430	493	555	618
-30	157	235	315	394	473	553	633	714	795
-40	192	288	384	481	579	676	774	872	971
-50	226	340	454	569	684	799	915	1031	1148

Table III-3-4-App A-5. Temperature correction to be used in calculating the FAS angle and effective VPA (ft) (Non-SI)

<i>Aerodrome temperature (°C)</i>	<i>Height of FAP above threshold at 3 000 ft AMSL (ft)</i>								
	<i>1 000</i>	<i>1 500</i>	<i>2 000</i>	<i>2 500</i>	<i>3 000</i>	<i>3 500</i>	<i>4 000</i>	<i>4 500</i>	<i>5 000</i>
50	-146	-219	-292	-366	-440	-514	-589	-663	-738
40	-110	-165	-221	-277	-332	-389	-445	-501	-558
30	-74	-112	-149	-187	-225	-263	-301	-339	-378
20	-39	-58	-78	-98	-118	-137	-157	-177	-197
10	-3	-5	-7	-8	-10	-12	-14	-15	-17
0	32	48	65	81	97	114	130	147	163
-10	68	102	136	170	205	239	274	309	344
-20	103	155	207	260	312	365	418	471	524
-30	139	209	279	349	420	490	562	633	704
-40	174	262	350	438	527	616	705	795	885
-50	210	316	421	528	635	742	849	957	1065

Table III-3-4-App A-6. Temperature correction to be used in calculating the FAS angle and effective VPA (ft) (Non-SI)

<i>Aerodrome temperature (°C)</i>	<i>Height of FAP above threshold at 6 000 ft AMSL(ft)</i>								
	<i>1 000</i>	<i>1 500</i>	<i>2 000</i>	<i>2 500</i>	<i>3 000</i>	<i>3 500</i>	<i>4 000</i>	<i>4 500</i>	<i>5 000</i>
50	-170	-256	-342	-428	-515	-602	-689	-776	-864
40	-134	-201	-269	-337	-405	-473	-542	-611	-680
30	-98	-147	-196	-246	-295	-345	-395	-445	-496
20	-61	-92	-123	-154	-185	-217	-248	-280	-311
10	-25	-38	-50	-63	-76	-88	-101	-114	-127
0	11	17	23	28	34	40	46	52	57
-10	48	72	96	120	144	168	193	217	242
-20	84	126	169	211	254	297	340	383	426
-30	120	181	241	302	364	425	486	548	610
-40	157	235	314	394	473	553	633	714	795
-50	193	290	387	485	583	681	780	879	979

Appendix B to Chapter 4

ALGORITHM FOR CALCULATING THE HEIGHT OF SURFACE DEFINED BY FOUR POINTS IN SPACE

The height (Z) of a point in the OAS side surface located at (X, Y) , between the origin of the FAS at threshold level (X_{FAS}) and ATT before THR at threshold level, could be calculated using the four vertices of the surface $(X1, Y1, Z1)$, $(X2, Y2, Z2)$, $(X3, Y3, Z3)$, $(X4, Y4, Z4)$ and the following formulae (see Figure III-3-4-App B-1):

Calculation of Z at (X, Y) :

$$X5 = X$$

$$Y5 = Y1 + (Y2 - Y1) \times ((X1 - X) / (X1 - X2))$$

$$Z5 = Z1 + (Z2 - Z1) \times ((X1 - X) / (X1 - X2))$$

$$X6 = X$$

$$Y6 = Y3 + (Y4 - Y3) \times ((X3 - X) / (X3 - X4))$$

$$Z6 = Z3 + (Z4 - Z3) \times ((X3 - X) / (X3 - X4))$$

Finally, calculate the required height Z as follows:

$$Z = Z5 + (Z6 - Z5) \times ((Y - Y5) / (Y6 - Y5))$$

Definitions of vertices

$$X1 = X3 = X_{FAS}$$

$$X2 = X4 = ATT$$

$Y1$ and $Y2$ = distance of edge of primary area at X_{FAS} and ATT respectively

$Y3$ and $Y4$ = distance of edge of secondary area at X_{FAS} and ATT respectively

$$Z1 = Z2 = 0$$

$$Z3 = Hi$$

$$Z4 = 30m$$

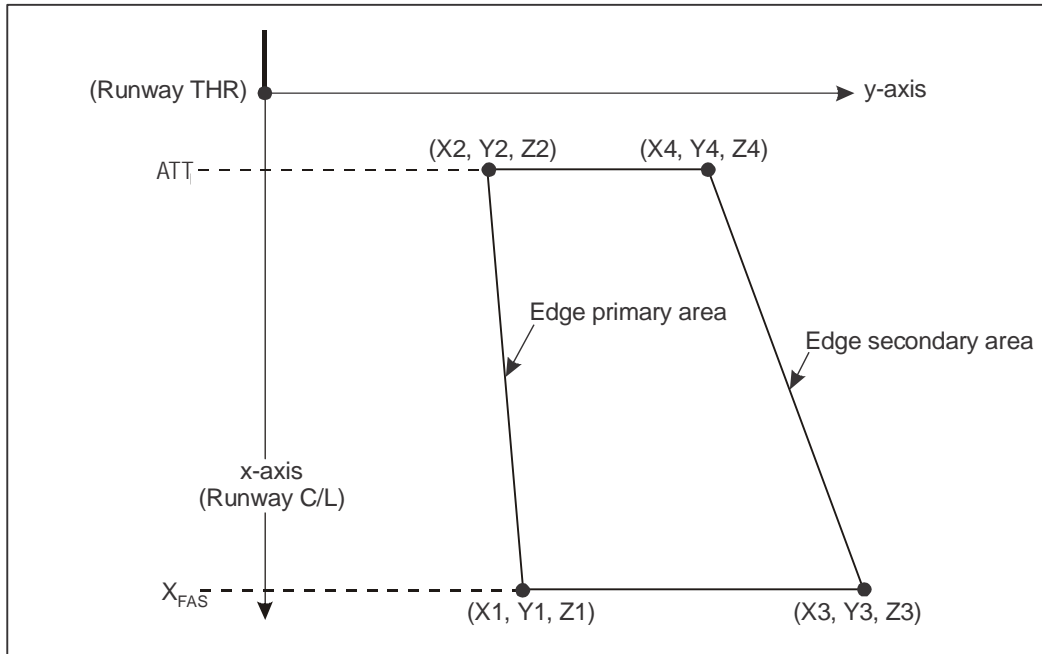

Figure III-3-4-App B-1. Explanation of surface vertices

Chapter 5

SBAS NON-PRECISION APPROACH, APPROACH WITH VERTICAL GUIDANCE AND PRECISION APPROACH CAT I PROCEDURES

5.1 INTRODUCTION

5.1.1 Procedure construction

This chapter describes the SBAS criteria for the NPA, APV 1 and PA CAT I procedure segment, which are specific to the performance of SBAS systems. Throughout this Chapter SBAS OAS refers to both SBAS APV OAS and SBAS CAT I OAS. The APV or CAT I segment includes the final approach, and the initial and the intermediate phases of the missed approach segment. The other phases of flight are generic in character and are presented in Part III, Section 3, Chapter 1 and Chapter 2.

Note.— SBAS Category I may be constructed using the ILS Category I CRM and/or the ILS Category I OAS. GNSS requirements for SBAS category I procedures can be found in Annex 10, Volume I, Attachment D, paragraphs 3.3.6 to 3.3.13.

5.1.2 Standard conditions

The following list contains the standard assumptions on which procedures are developed. Provisions are made for adjustments where appropriate. Adjustments are mandatory when conditions differ adversely from standard conditions and are optional when so specified.

- a) maximum aircraft dimensions are assumed to be the following:

<i>Aircraft category</i>	<i>Wingspan</i>	<i>Vertical distance between the flight paths of the wheels and the centre of navigation (m)</i>
H	30	3
A, B	60	6
C, D	65	7
D _L	80	8

Note 1.— OCA/H for D_L aircraft are published when necessary.

Note 2.— The dimensions shown are those which encompass current aircraft types. They are chosen to facilitate OCA/H calculations and promulgation of aircraft category related minima. It is assumed that these dimensions are not intended to be used for other purposes than the OCA/H calculations in other ICAO documents.

Note 3.— Current Category E aircraft are not normally civil transport aircraft and their dimensions are not necessarily related to V_{at} at maximum landing mass. For this reason, they should be treated separately on an individual basis.

- b) missed approach climb gradient 2.5 per cent;
- c) glide path angle:
 - 1) minimum/optimum: 3.0°
 - 2) maximum: 3.5°
- d) reference datum height 15 m (50 ft); and
- e) all obstacle heights are referenced to threshold elevation.

5.1.3 Obstacle clearance altitude/height (OCA/H)

The SBAS criteria in this chapter enable an OCA/H to be calculated for each category of aircraft.

The OCA/H ensures clearance of obstacles from the start of the final approach to the end of the intermediate missed approach segment.

Note.— This OCA/H is only one of the factors to be taken into account in determining decision height as defined in Annex 6.

5.2 INITIAL APPROACH SEGMENT

See Chapter 2, 2.3.1.1, “Initial approach alignment”.

5.3 INTERMEDIATE APPROACH SEGMENT

5.3.1 *General.* In the intermediate approach segment any sensor can be used; however, the transition to the SBAS navigation shall be made 3.7 km (2.0 NM) prior to the FAF.

5.3.2 *Alignment.* The intermediate approach segment of an SBAS procedure shall be aligned with the final approach segment.

5.3.3 *Area width.* The total area width is as described in Chapter 2, 2.4.3, “Intermediate approach area width”. From 3.7 km (2.0 NM) to the FAF the area tapers uniformly to match the horizontal distance between the SBAS APV OAS X surfaces at the FAF. The secondary area width decreases to zero at the interface with the final approach surfaces (see Figure III-3-5-1 a)).

Note.— According to the length of the final approach segment, the SBAS APV OAS X surface width at the final approach fix can be less than 1.9 NM. In this case, to provide protection to an aircraft that initiates an early missed approach, a 3.52 km (1.90 NM) value (for helicopters 2.96 km (1.60 NM)) is considered for area width of the intermediate approach segment at the final approach fix (see Figure III-3-5-1 b)).

5.4 APV OR CAT I SEGMENT

5.4.1 *General.* The APV I or CAT I segment of an SBAS APV I or CAT I approach procedure shall be aligned with the runway centre line and contain the final approach, the initial and the intermediate missed approach segments.

5.4.2 *Origin.* The APV I or CAT I segment starts at the final approach point (the intersection of the nominal vertical path and the minimum altitude specified for the preceding segment). For navigation database coding purposes, the waypoint located at the FAP shall not be considered as a descent fix. The SBAS OAS surfaces extend into the intermediate approach segment but not beyond this segment (see Figure III-3-5-2).

Note.— *Guidance material for determining the distance to the FAP from the threshold is contained in Part II, Section 1, Chapter 1, Appendix C.*

5.4.3 *Missed approach point.* The missed approach point is defined by the intersection of the nominal vertical path and the decision altitude/height (DA/H). The DA/H is set at or above the OCA/H, which is determined as specified in 5.4.5 and 5.5.

5.4.4 *Termination.* The APV I or CAT I segment terminates at the point where the final phase of the missed approach commences or where the missed approach climb surface Z reaches a semi-width of 1.76 km (0.95 NM) (for helicopters 1.48 km (0.8 NM)), whichever occurs first.

5.4.5 Obstacle clearance of the SBAS APV I or CAT I segment

5.4.5.1 *General.* The method of calculating OCA/H involves a set of obstacle assessment surfaces (SBAS OAS). If the SBAS OAS are not penetrated, the OCA/H is still defined by the aircraft category margins. However, if the SBAS OAS are penetrated, the aircraft category margin is added to the highest approach obstacle, or the adjusted height of the largest missed approach penetration, whichever is greater. This value becomes the OCA/H.

5.4.5.2 The SBAS OAS dimensions are related to the approach geometry (GARP/THR distance, GP, RDH) and the SBAS procedure type (APV I or CAT I). The obstacles penetrating the SBAS OAS are divided into two classes, approach obstacles and missed approach obstacles. The height of the highest approach obstacle or the adjusted missed approach surface penetration (see 5.4.5.9.2) is determined and added to an aircraft category related margin to obtain the appropriate OCA/H. Thus, a table of OCA/H values for each aircraft category may be promulgated for SBAS operations at the particular aerodrome.

Note.— *At this stage, the SBAS APV OAS method is the only one applicable to calculate the OCA/H of the APV I segment. A CRM for these procedures is currently under development. Use of the ILS CAT I CRM is permitted to calculate the SBAS CAT I OCA/H.*

5.4.5.3 *Definition of surfaces.* The SBAS OAS consists of up to seven sloping plane surfaces (denoted by letters W, W', X, Y, and Z) disposed symmetrically about the APV I or CAT I segment track and the horizontal plane containing the threshold (see Figure III-3-5-2). The SBAS CAT I OAS contains the following sloping surfaces: W, X, Y and Z, which are equal to the ILS CAT I OAS surfaces. The geometry of the sloping surfaces is precisely defined by four simple linear equations of the form $z = Ax + By + C$. In these equations, x and y are position coordinates and z is the height of the surface at that position. For each surface the constants A, B and C are obtained from the PANS-OPS OAS software (see <http://www.icao.int/safety/AirNavigation/OPS/Pages/PANS-OPS-OAS-Software.aspx>) for the operational range of GARP/THR distances and GP. Separate sets of constants are provided for APV I or CAT I. The SBAS CAT I OAS uses the ILS CAT I OAS constants. The constants may be modified by the programme to account for the following:

- a) missed approach climb gradient;
- b) dimensions of specific aircraft; and
- c) the height of the RDH above the nominal value.

The SBAS OAS Y and Z surfaces are laterally limited by a corridor of 1.76 km (0.95 NM) (for helicopters 1.48 km (0.8 NM)) area semi-width (see Figure III-3-5-2).

5.4.5.4 *Frame of reference.* Positions of obstacles are related to a conventional x, y, z coordinate system with its origin at the threshold (see Figure III-3-5-3). The x axis is parallel to the precision segment track, positive x being measured before threshold and negative x being measured after threshold. The y-axis is at right angles to the x-axis. Although shown conventionally in Figure III-3-5-3, in all calculations associated with SBAS OAS geometry, the y coordinate is always counted as positive. All dimensions connected with the SBAS OAS are specified in metres only. The z-axis is vertical, heights above threshold being positive.

5.4.5.5 *SBAS OAS constants — specification.* For SBAS procedures the constants A, B and C for each sloping surface are obtained from the PANS-OPS OAS software. The PANS-OPS OAS software gives coefficients for GP angles between 2.5 and 3.5 degrees in 0.1-degree steps, and for any GARP-threshold distance between 2 000 m and 4 500 m. For an example of the PANS-OPS OAS software results see Figure III-3-5-4.

5.4.5.6 *Calculation of SBAS APV I OAS heights.* To calculate the height z of any of the sloping surfaces at a location x', y', the appropriate constants should be first obtained from the PANS-OPS OAS software. These values are then substituted in the equation $z = Ax' + By' + C$. If it is not apparent which SBAS APV I OAS is above the obstacle location, this should be repeated for the other sloping surfaces. The SBAS APV OAS height is the highest of the X, Y, Z plane heights and the height of the lowest W-W' plane heights (zero if all the plane heights are negative). The SBAS CAT I OAS heights are calculated in the same way using the ILS CAT I OAS constants.

For APV I OAS, W and W' planes intersect, and the accountable W-W' plane is always the lower of these two planes, i.e. height of OAS = max [ZX; ZY; ZZ; min ZW; ZW']

Where ZX, ZY, ZZ, ZW and ZW' are the heights of the X, Y, Z, W and W' planes.

Note.— The PANS-OPS software also contains an OCH calculator that will show the height of the SBAS OAS surface Z above any X, Y location. It includes all the adjustments specified for the APV I or CAT I approach geometry, aircraft dimensions, missed approach climb gradient and RDH.

5.4.5.7 *SBAS OAS template construction.* Templates, or plan views of the SBAS OAS contours to map scale, are sometimes used to assist identification of obstacles for detail survey (see Figure III-3-5-5). The SBAS OAS data in the PANS-OPS software includes the coordinates of the points of intersection of the sloping surfaces at threshold level and at 1.9 km (1.0 NM) laterally from the final approach track (see Figure III-3-5-5). The intersection coordinates at threshold level are labelled as C, D and E.

5.4.5.8 *Adjustment of SBAS OAS constants.* Adjustments of SBAS OAS constants for specific aircraft dimensions and RDH different from 15 m are applied as in Part II, Section 1, Chapter 1, 1.4.8.7, “Adjustment of OAS constants”.

5.4.5.9 *Determination of OCA/H*

5.4.5.9.1 *General.* The OCA/H is determined by accounting for all obstacles which penetrate the SBAS OAS surfaces applicable to the operation type being considered. The surfaces which apply to each operation type are:

Type A, 3D operation: SBAS APV I OAS.

Type B, 3D operation: SBAS CAT I OAS.

5.4.5.9.2 *Determination of approach and missed approach obstacles.* The accountable obstacles, as determined in 5.4.5.9.1, are divided into approach and missed approach obstacles. The simplest method of partition is by range: approach obstacles are those between the FAP and range X_E after threshold, and missed approach obstacles are those in the remainder of the APV I segment (see Figure III-3-5-6). However, in some cases it may produce an excessive penalty for certain missed approach obstacles. Where desired by the appropriate authority, missed approach obstacles may therefore be defined as those above a plane surface parallel to the plane of the GP and with origin at X_E (see Figure III-3-5-7), i.e. obstacle height greater than $[(X - X_E) \tan \theta]$.

5.4.5.9.3 *Calculation of OCA/H.* After the approach and missed approach obstacles have been identified by one of the above described methods, the OCA/H is determined as follows:

- a) determine the height of the highest approach obstacle;
- b) reduce the heights of all missed approach obstacles to the heights of equivalent approach obstacles by the formula given below; and
- c) determine OCA/H by adding the appropriate Table II-1-1-2, “Height loss altimeter margin” aircraft category related margin to the height of the highest approach obstacle (real or equivalent).

$$h_a = \frac{h_{ma} * \cot Z + (X - X_E)}{[\cot Z + \cot \theta]}$$

where: h_a = height of equivalent approach obstacle
 h_{ma} = height of missed approach obstacle
 θ = VPA
 Z = angle of missed approach surface
 X = range of obstacles relative to threshold (negative after threshold)
 X_E = 900 + (38/tan θ) for APV I
 For CAT H, X_E = 700 + (38/tan θ) for APV I h_{ma} , X and X_E are expressed in metres (m)

Note.— For SBAS Category I operations, OCA/H calculations may use the ILS Category I OCA/H calculation.

5.4.5.9.4 *Adjustment for high airfield elevations and steep glide path angles*

5.4.5.9.4.1 *Height loss (HL)/altimeter margins.* The margins in Table II-1-1-2 shall be adjusted as follows:

- a) for airfield elevations higher than 900 m (2 953 ft), the tabulated allowances shall be increased by 2 per cent of the radio altimeter margin per 300 m (984 ft) airfield elevation; and
- b) for glide path angles greater than 3.2°, in exceptional cases, the allowances shall be increased by 5 per cent of the radio altimeter margin per 0.1° increase in glide path angle between 3.2° and 3.5°.

5.4.5.9.4.2 *Steep glide path angle.* Procedures involving glide paths greater than 3.5° or any angle when the nominal rate of descent (V_{at} for the aircraft type multiplied by the sine of the glide path angle) exceeds 5 m/s (1 000 ft/min) are non-standard for fixed-wing aircraft. They require the following:

- a) increase of height loss margin (which may be aircraft-type specific);
- b) adjustment of the origin of the missed approach surface;
- c) adjustment of the slope of the SBAS APV I OAS W and W' surfaces or for SBAS CAT I OAS adjustment of the W surface;
- d) re-survey of obstacles; and
- e) the application of related operational constraints.

Such procedures are normally restricted to specifically approved operators and aircraft and are associated with appropriate aircraft and crew restrictions. For fixed-wing aircraft they are not to be used as a means to introduce noise abatement procedures.

5.4.5.9.4.3 The appendix shows the procedure design changes required for APV SBAS procedures for glide path angles up to 6.3° (11 per cent) and the related operational/certification considerations.

5.5 MISSED APPROACH SEGMENT

5.5.1 General

5.5.1.1 The criteria for the final missed approach are based on those for the general criteria (see Part I, Section 4, Chapter 6) with certain modifications to allow for the different areas and surfaces associated with the APV I or CAT I segment and the possible variation in OCA/H for that segment with aircraft category.

5.5.1.2 The datum used for calculation of distances and gradients in obstacle clearance calculations is termed “start of climb” (SOC). It is defined by the height and range at which the plane GP' reaches an altitude OCA/H – HL (where OCA/H and HL both relate to the same category of aircraft).

5.5.1.3 Where obstacles identified in the final missed approach segment result in an increase in any of the OCA/H calculated for the APV I or CAT I segment, a higher gradient of the missed approach surface (Z) may be specified in addition if this will provide clearance over those obstacles at a specified lower OCA/H (see Part I, Section 4, Chapter 6, 6.2.2.2).

5.5.2 Straight missed approach

5.5.2.1 *Termination of the APV I or CAT I segment.* The APV I or CAT I segment terminates at the range where the Z surface reaches a semi-width of 1.76 km (0.95 NM) (for helicopters 1.48 km (0.8 NM)). For the straight part of the final missed approach the area semi-width is equal to 1.76 km (0.95 NM) (for helicopters 1.48 km (0.8 NM)). Secondary areas are not applied. (See Figure III-3-5-8).

5.5.2.2 *Obstacle clearance.* (See Figure III-3-5-9). Obstacle elevation/height in this final missed approach area shall be less than

$$(OCA/H_{APV} - HL) + d_o \tan Z$$

where:

- OCA/H_{APV} and HL both relate to the same aircraft category.
- d_o is measured from SOC parallel to the straight missed approach track.
- Z is the angle of the missed approach surface with the horizontal plane.

If this criterion cannot be met, a turn shall be prescribed to avoid the offending obstacle, or if this proves impractical, the OCA/H shall be raised.

5.5.3 Turning missed approach

5.5.3.1 *General.* For SBAS APV I procedures, the missed approach turn shall be prescribed at a designated TP. Turns at a designated altitude/height or “as soon as practicable” cannot be implemented because of the current SBAS receiver capabilities. The criteria used depend on the location of the turn relative to the threshold and the normal termination of the APV I or CAT I segment and are as follows:

- a) *turn outside APV I or CAT I segment.* If a turn is prescribed after the normal termination range of the APV I or CAT I segment, the general criteria of Part I, Section 4, Chapter 6, 6.4.6.4 apply with the following exceptions:
 - 1) OCA/H is replaced by (OCA/H_{APV} – HL); and
 - 2) because SOC is related to OCA/H, it is not possible to obtain obstacle clearance by the means used in the general criteria by independent adjustment of OCA/H or MAPt.
- b) *turn inside APV I or CAT I segment.* If a turn is prescribed at a designated TP such that the earliest TP is within the normal termination range, the criteria specified in 5.5.3.2 and 5.5.3.3 below shall be applied.

5.5.3.2 *Turn at a designated TP after the threshold with earliest TP before normal termination of APV I or CAT I segment.* Where a turn is specified at a designated TP after the threshold, and the earliest TP is before the normal termination range of the APV I or CAT I segment, the APV I or CAT I segment is curtailed and terminates at the earliest TP. This allows the calculation of OCA/H_{APV} and (OCA/H_{APV} – HL); SOC is then determined.

5.5.3.2.1 *Area.* The turn area is constructed as specified in Part I, Section 4, Chapter 6, 6.4.6, “Turn initiated at a designated turning point”, except that it is based on the width of the SBAS OAS Y surface contours at the earliest and latest TP (see Figure III-3-5-10).

5.5.3.2.2 *Obstacle clearance.* Obstacle elevation/height shall be less than:

$$(OCA/H_{APV} - HL) + d_o \tan Z - MOC$$

where:

- d_o = d_z + shortest distance from obstacle to line K-K'; and
- d_z = horizontal distance from SOC to the earliest TP,
- MOC = 50 m (164 ft) (Cat H, 40 m (132 ft)) for turns more than 15° and 30 m (98 ft) for turns 15° or less.

If the obstacle elevation/height exceeds the OCA/H_{APV}, the OCA/H_{APV} shall be increased, or the TP moved to obtain the required clearance.

5.5.3.3 *Turn at a designed TP before the threshold.* A turn at a designated TP before the threshold may be prescribed to avoid obstacles located early in the straight missed approach. (See Figure III-3-5-11, obstacle 0₁). For such procedure the Final Approach Segment (FAS) data block shall be implemented using a Fictitious Threshold Point (FTP) located at the TP.

5.5.3.3.1 *Turning point.* A latest turning point is chosen to allow the aircraft to avoid obstacles straight ahead. Then the turning point (TP) is plotted before the latest TP at a distance equivalent to 0.6 km (0.3 NM) plus 6 seconds of flight (pilot reaction and bank establishing time) at the final missed approach speed (or maximum published missed approach speed) plus 56 km/h (30 kt) tailwind. For this kind of turn the SOC is coincident with the earliest TP and the APV I or CAT I segment terminates at this point. The OCA/HAPV is equal to the altitude/height of the SOC increased by the HL value.

5.5.3.3.2 *Areas.* The turn area is constructed as specified in Part I, Section 4, Chapter 6, except that it is based on the width of the SBAS OAS Y surface contours at the earliest and latest TP (see Figure III-3-5-11).

5.5.3.3.3 *Obstacle clearance.* Obstacle elevation/height shall be less than:

$$(OCA/H_{APV} - HL) + d_o \tan Z - MOC$$

where:

d_o = shortest distance from obstacle to line K-K',

and MOC is:

50 m (164 ft) (Cat H, 40 m (132 ft) for turns more than 15° and 30 m (98 ft) for turns 15° or less.

5.6 SIMULTANEOUS ILS/MLS/GBAS/APV SBAS APPROACHES TO PARALLEL OR NEAR-PARALLEL INSTRUMENT RUNWAYS

Note.— *Guidance material is contained in the Manual on Simultaneous Operations on Parallel or Near-Parallel Instrument Runways (SOIR) (Doc 9643).*

5.6.1 General

When it is intended to use an APV I or CAT I SBAS approach procedure to parallel runways, simultaneously with ILS, MLS, GBAS or another APV I or CAT I SBAS approach procedure, the following additional criteria shall be applied in the design of both procedures:

- a) the maximum intercept angle with the final approach course approach track is 30°. The point of intercepting the final approach track course should be located at least 3.7 km (2.0 NM) prior to the point of intercepting the glide path;
- b) the minimum altitudes of the intermediate segments of the two procedures differ by at least 300 m (1 000 ft); and
- c) the nominal tracks of the two missed approach procedures diverge by at least 30°, the associated missed approach turns being specified as “as soon as practicable” which may involve the construction of (a) missed approach procedure(s).

5.6.2 Obstacle clearance

The obstacle clearance criteria for APV I and CAT I SBAS and precision approaches, as specified in the designated chapters, apply for each of the parallel approach procedures. In addition to these criteria, a check of obstacles shall be made in the area on the side opposite the other parallel runway, in order to safeguard early turns required to avoid potential intruding aircraft from the adjacent runway. This check can be made using a set of separately defined parallel approach obstacle assessment surfaces (PAOAS). An example of a method to assess obstacles for these procedures is included in Part II, Section 1, Chapter 1, Appendix D.

5.7 SBAS APPROACH WITH OFFSET FINAL APPROACH TRACK ALIGNMENT

5.7.1 Use of SBAS approach with offset alignment

5.7.1.1 In certain cases it may not be physically practicable to align the final approach segment with the runway centre line because of obstacle problems. An offset final approach track shall not be established as a noise abatement measure. The final approach track shall intersect the runway extended centre line:

- a) at an angle not exceeding 5°; and
- b) at a point where the nominal glide path reaches a height called intercept height of at least 55 m (180 ft) above threshold.

5.7.1.2 The procedure shall be annotated: “final approach track offset ... degrees” (tenth of degrees).

5.7.1.3 The general arrangement is shown in Figure III-3-6-24.

5.7.2 Obstacle clearance criteria

The provisions contained in 5.1 to 5.5 apply except that:

- a) all the obstacle clearance surfaces and calculations are based on a fictitious runway aligned with the final approach track. This fictitious runway has the same length and the same landing threshold elevation as the real one. The FTP and the course width at the FTP are analogous to the LTP for an aligned procedure. The DCP is located 15 m (50 ft) above the FTP; and
- b) the OCA/H for this procedure shall be at least: intercept altitude/height + 20 m (66 ft).

5.8 SBAS NPA

5.8.1 *Final approach segment.* The final approach segment areas are formed by using the outer lateral boundaries of the X surfaces beginning at threshold and extending until reaching a semi-width of 1 760 m (0.95 NM) and continuing at that semi-width at greater distances. This occurs at approximately 11.7 km (6.3 NM), depending on the distance from LTP to GARP. A secondary area is formed based on a primary width of 880 m (0.475 NM). The secondary area continues at this width toward the threshold until reaching the semi-width of the X surfaces. At this point the secondary area width diminishes to zero.

5.8.1.1 *Final approach segment semi-width surfaces.* The semi-width of the final approach surfaces shall be determined using the following formulae:

$$Y_{LTP} = [-0.0031 (GARP - LTP) + 182.83] \text{ metres and}$$

$$\theta_x = [-0.0006 (GARP - LTP) + 9.4367] \text{ degrees}$$

where:

Y_{LTP} is the semi-width of the final approach surface at the LTP/FTP.

θ_x is the angle of splay outward from the LTP/FTP of the final approach surface (see Figures III-3-5-12 and III-3-5-13).

W/2 is computed as: $Y_{LTP} +$ the distance from the LTP/FTP multiplied by $\tan \theta_x$.

5.8.2 *Intermediate segment.* The intermediate segment is joined to the final segment by constructing a line from the outer boundary of the intermediate segment to the outer boundary of the X surface at 30 degrees to the track and passing through the specified semi-width at the FAF/FAP. See Figure III-3-5-14.

5.8.3 *Missed approach segment.* The missed approach area shall start at the early ATT of the MAPt, with a splay of 15 degrees each side of the outer boundary of the final segment (X surface lateral boundaries). Secondary areas shall be applied when the expanded semi-width reaches the appropriate dimension for the RNP or RNAV navigation accuracies applied for missed approach guidance.

5.8.3.1 The obstacle evaluations and establishment of the OCA/H shall be carried out in the same manner as the LNAV criteria.

5.9 PROMULGATION

5.9.1 The general criteria in Part I, Section 4, Chapter 9, 9.5, “Procedure naming for arrival and approach charts” apply. The instrument approach chart for an SBAS approach procedure shall be identified by the title RNAV_(GNSS) or RNP Rwy XX in accordance with Part III, Section 5, Chapter 1.

5.9.2 *Promulgation of OCA/H for SBAS approach procedures.* The OCA/H values shall be promulgated for those categories of aircraft for which the procedure is designed. The values shall be based on the following standard conditions:

- a) approach flown with barometric altimeter;
- b) standard aircraft dimensions (see 6.1.3); and
- c) 2.5 per cent missed approach climb gradient.

Additional values of OCA/H may be agreed between operators and appropriate authority and promulgated, on the basis of evidence supporting the modifications defined in 5.4.5.7.

5.9.3 *Minima box.* All APV I and CAT I SBAS OCA/Hs are promulgated as LPV lines of minima. All NPA SBAS OCA/Hs shall be promulgated as LP (localizer performance) lines of minima. LPV and LP lines of minima shall not be published on the same chart.

5.9.4 *Additional gradient for the final missed approach segment.* If obstacles identified in the final missed approach segment result in an increase in any of the OCA/H calculated for the precision segment, an additional steeper gradient may also be specified for the gradient of the missed approach surface (Z) for the purpose of lowering the OCA/H (see Part I, Section 4, Chapter 6, 6.2, “Climb gradient and MOC”).

Note.— For further requirements in PBN charting, see Part III, Section 5, Chapter 1.

5.9.5 *Final approach segment data block (FAS DB).* The FAS DB is specified in Part III, Section 3, Chapter 6. It shall be promulgated in a textual format on the verso of the approach chart or a separate sheet, and shall contain at least the data indicated in Table III-3-5-1.

Table III-3-5-1. Example of textual description of data required for the final approach segment data block

<i>Data Content</i>	<i>Example Data</i>
Operation Type	0
SBAS Provider Identifier	1
Airport Identifier	LFLC
Runway Number	26
Runway Letter	
Approach Performance Designator	0
Route Indicator	Z
Reference Path Data Selector	0
Reference Path Identifier	E26A
LTP/FTP Latitude	454718.3185N
LTP/FTP Longitude	0031114.4545E
LTP/FTP Height above ellipsoid	372.3
FPAP Latitude	454705.1260N
FPAP Longitude	0030900.4790E
Approach Threshold Crossing Height (TCH)	15
Approach TCH Units Selector	1
Glidepath Angle (GPA)	3
Course Width at threshold	105
Length Offset	48
Horizontal Alert Limit (HAL)	40
Vertical Alert Limit (VAL)	0
Final Approach Segment CRC	AB8761C6

5.9.6 SBAS FAS DB Information to be promulgated. The following information shall be promulgated for SBAS APV procedures:

- a) *Channel number.* A globally unique channel number in the range 40 000 to 99 999.
- b) *Reference path identifier (RPI).* The RPI as defined in Part III, Section 2, Chapter 6, Appendix B, paragraph 3.5, with the procedure information. This is required for charting and data base encoding.

- c) *SBAS service provider*. Since for SBAS vertically guided procedures information from different SBAS cannot be mixed, the leading alpha character in the Reference Path Identifier (RPI) field may be used to identify the service provider.

Examples:

W17A for WAAS
E22A for EGNOS.

- d) *FPAP and LTP orthometric height*. The “orthometric height” field is the height of a surveyed point in reference to mean sea level (MSL). It shall be included with the procedure data and expressed in metres with a resolution of a tenth a metre.

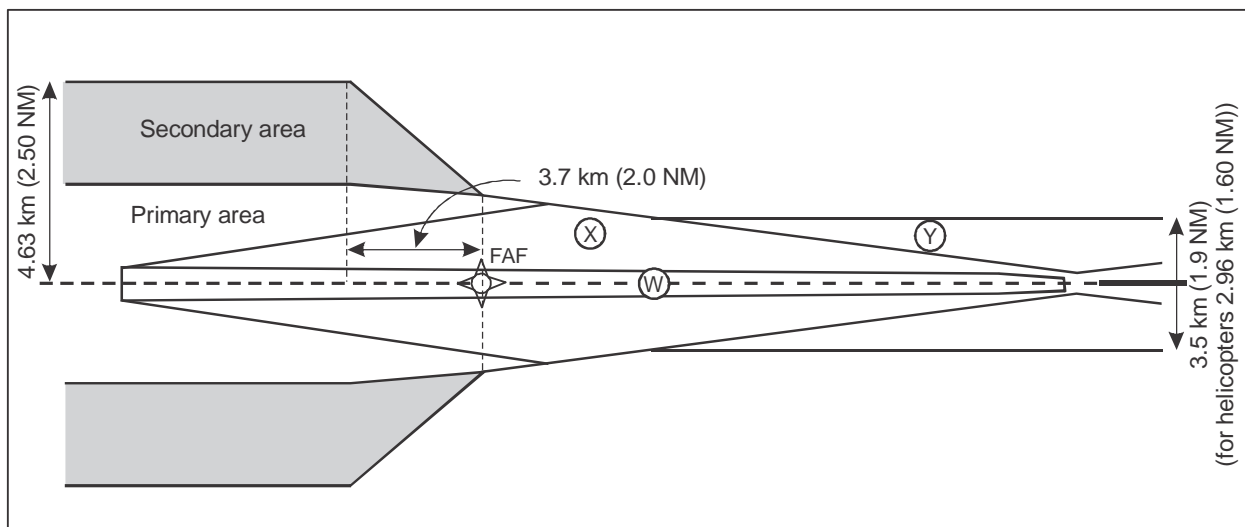

Figure III-3-5-1 a). Intermediate approach area (fully based on SBAS). FAF far away from the threshold (X surface width more than 3.7 km (2.0 NM) at the FAF)

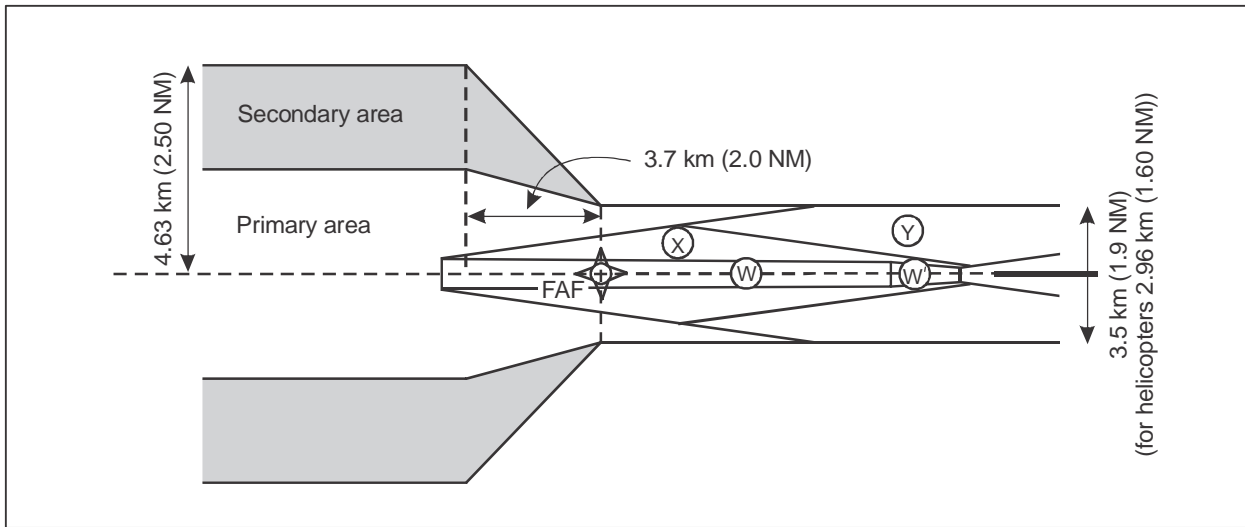

Figure III-3-5-1 b). Intermediate approach area (fully based on SBAS). FAF close to the threshold (X surface width less than 3.7 km (2.0 NM) at the FAF)

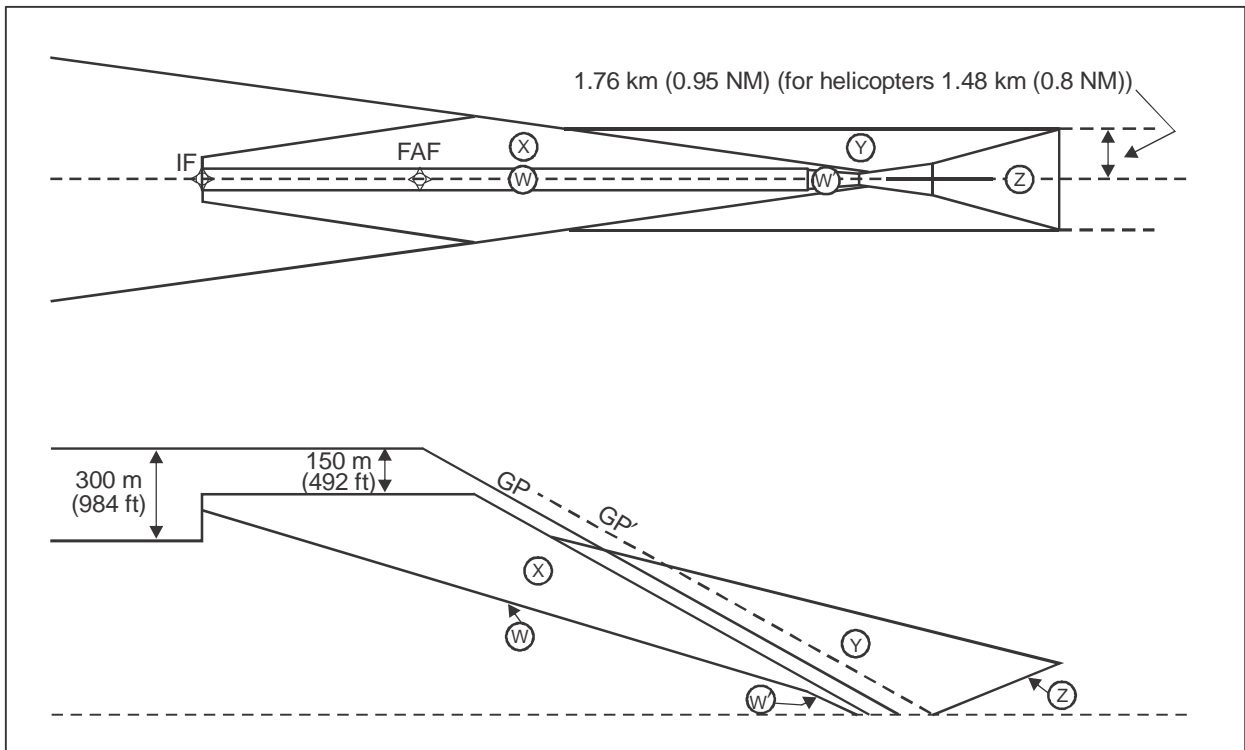

Figure III-3-5-2. Illustration of SBAS APV obstacle assessment surfaces (plan view and profile view)

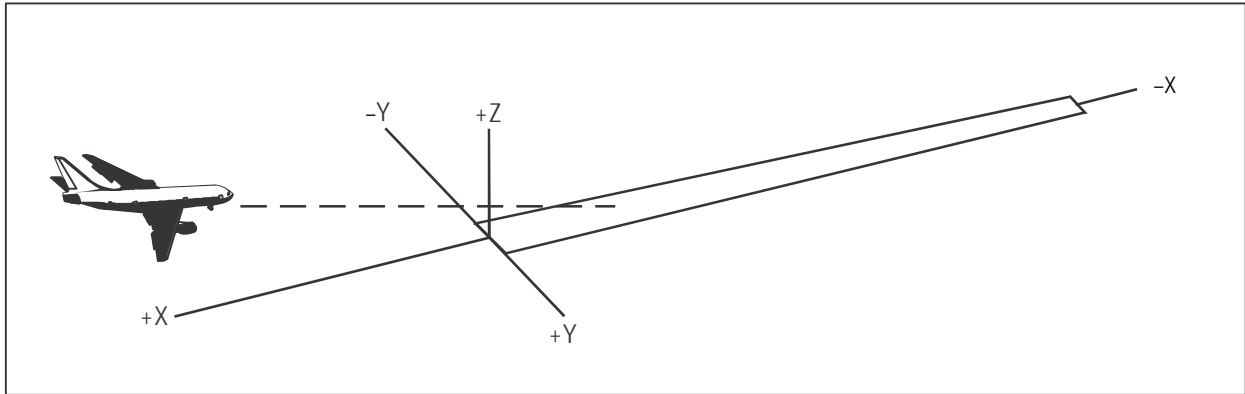

Figure III-3-5-3. System of coordinates

NAVIGATION AID DATA

Approach Category:

GP/WPA (*): LOC THR Dist ⁽¹⁾: m

RDH: m Course width at THR: m

AIRCRAFT DATA

M/App CG (%): CAT: STD: Wing Semi Span: m GP Wheel / Antenna height: m

OAS constants

	A	B	C		A	B	C
W	0.028500	0.000000	-8.01	Y	0.023948	0.210054	-59.51
W*	0.039290	0.000000	-38.75	Z	-0.025000	0.000000	-60.50
X	0.027681	0.182500	-54.72				

OAS Template coordinates -m (metres)

	THR Elevation		Upper coordinates			
	X	Y	X	Y	Z	
C	281	257	C"	10807	304	300
D	438	233	C'''	2849	268	73
E	-2420	559	D"	6163	1008	300
			E"	-7967	1852	199

Y surface template contours are parallel to line D-E.

OAS height calculator

X: m Y: m Z: m

(1) For MLS read: "Azimuth antenna to THR distance"; for GBAS/APV read: "GARP-LTP distance".

Figure III-3-5-4. Example of PANS-OPS software input/output screen

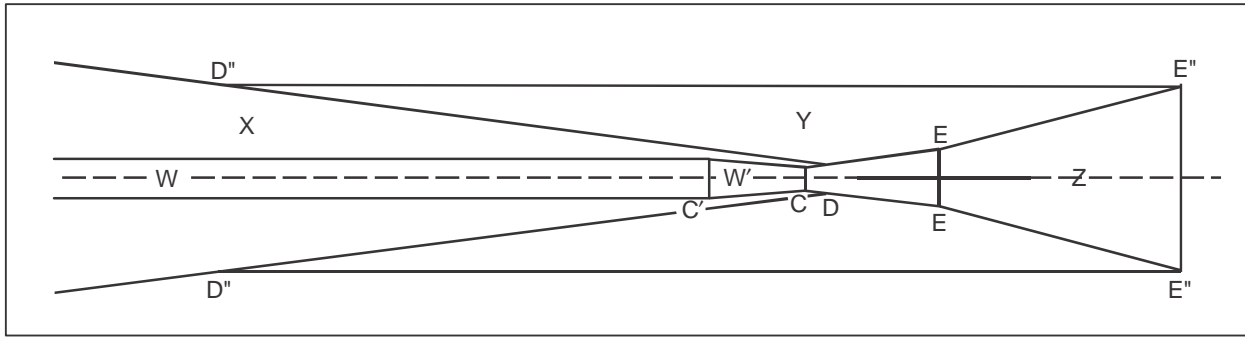

Figure III-3-5-5. Typical SBAS APV I OAS contours for standard size aircraft

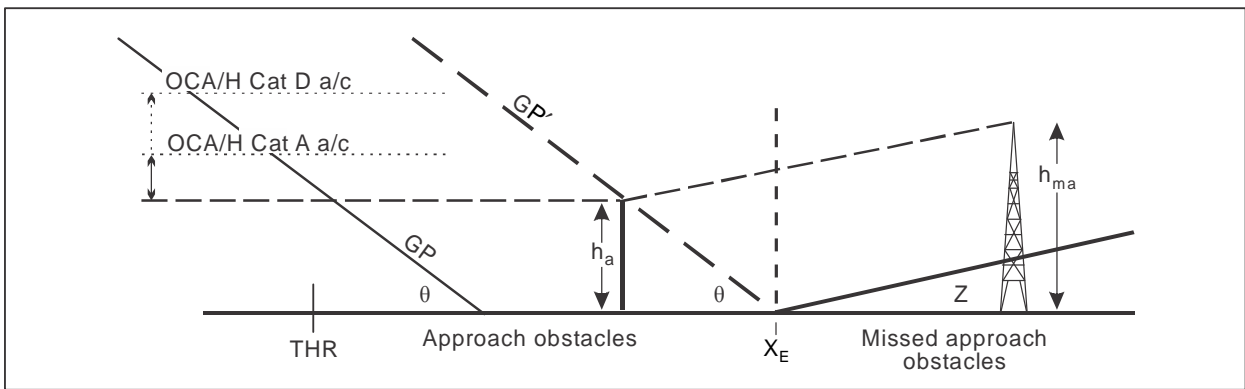

Figure III-3-5-6. Missed approach obstacle after range X_E

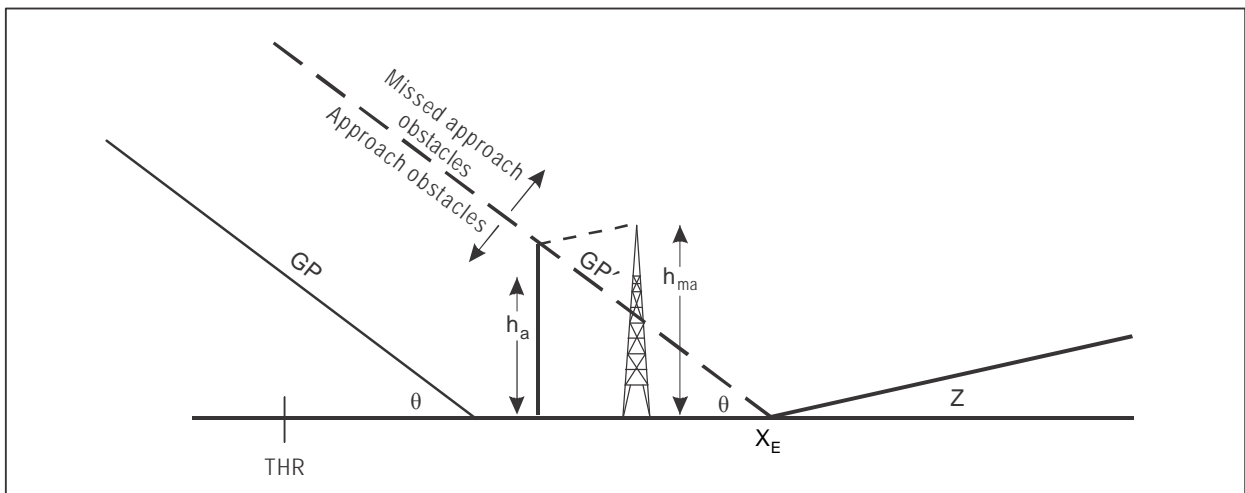

Figure III-3-5-7. Missed approach obstacle before range X_E

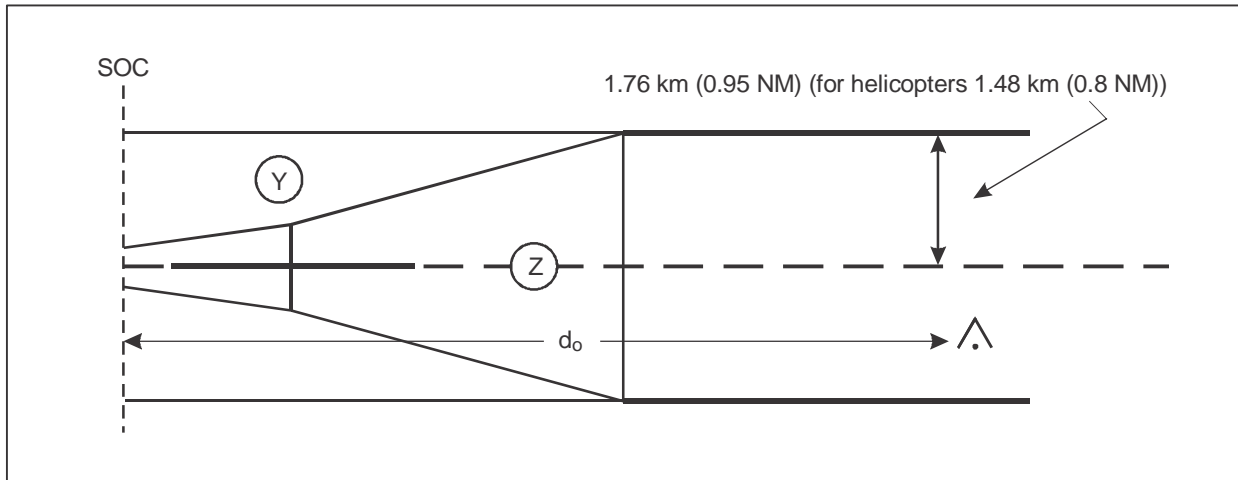

Figure III-3-5-8. Final segment of straight missed approach

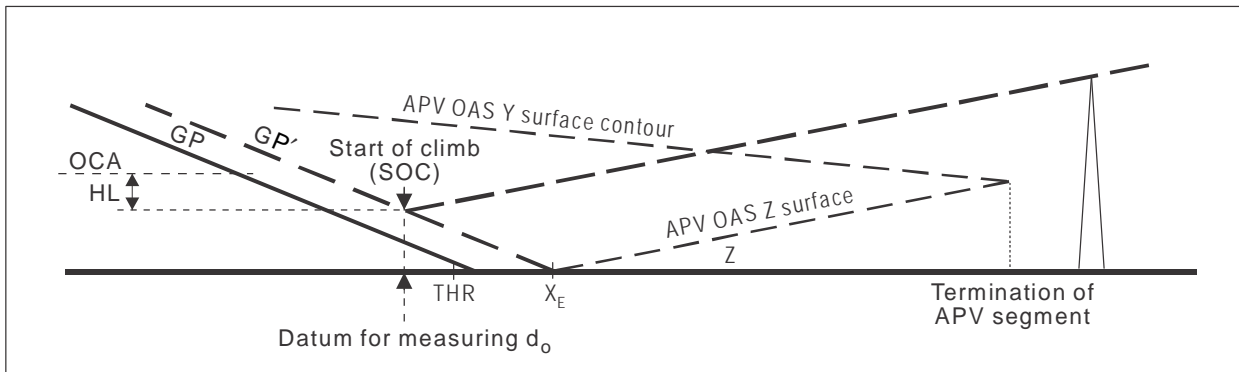

Figure III-3-5-9. Straight missed approach obstacle clearance

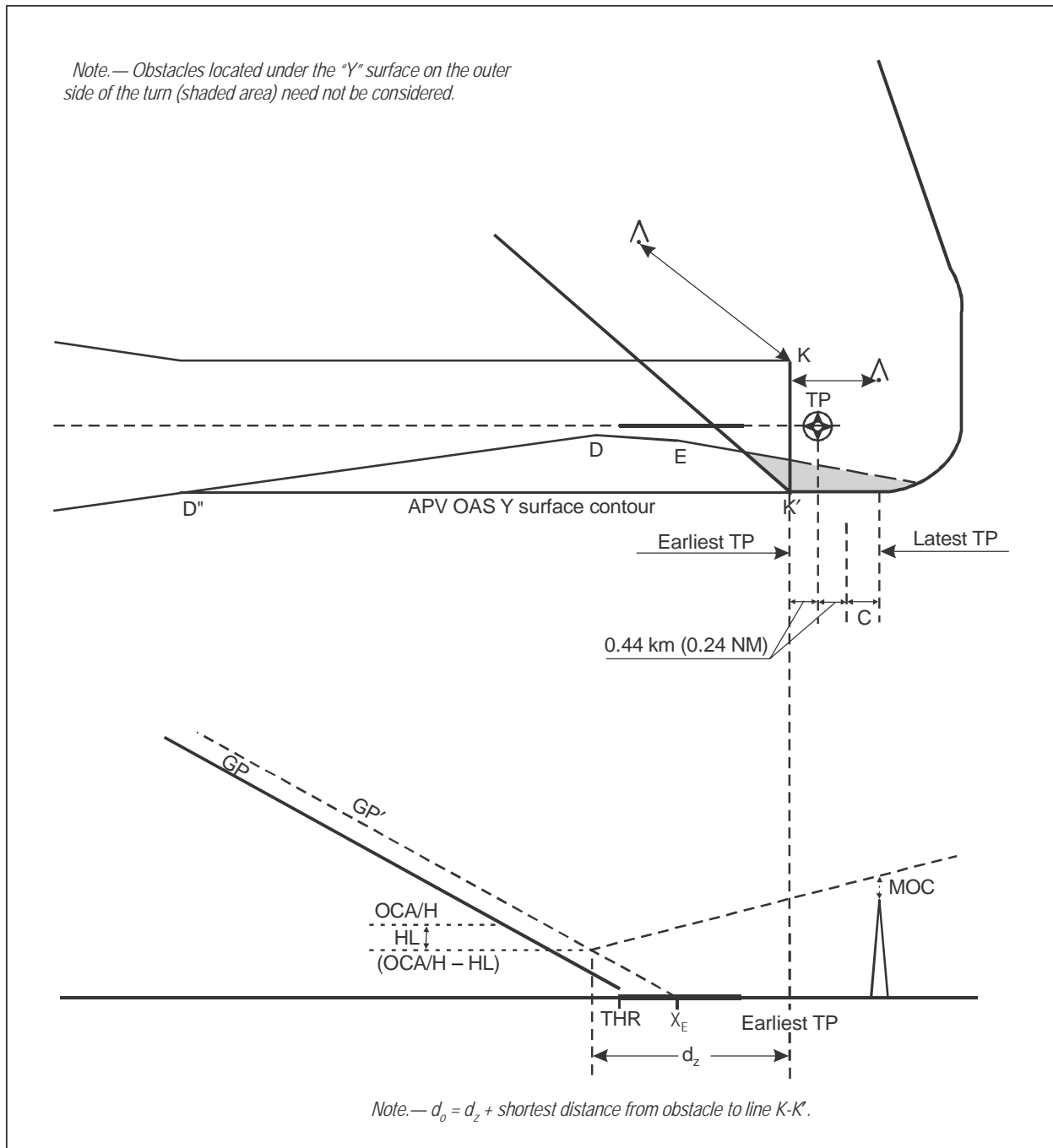

Figure III-3-5-10. Turn at designated TP (flyover waypoint) after the threshold

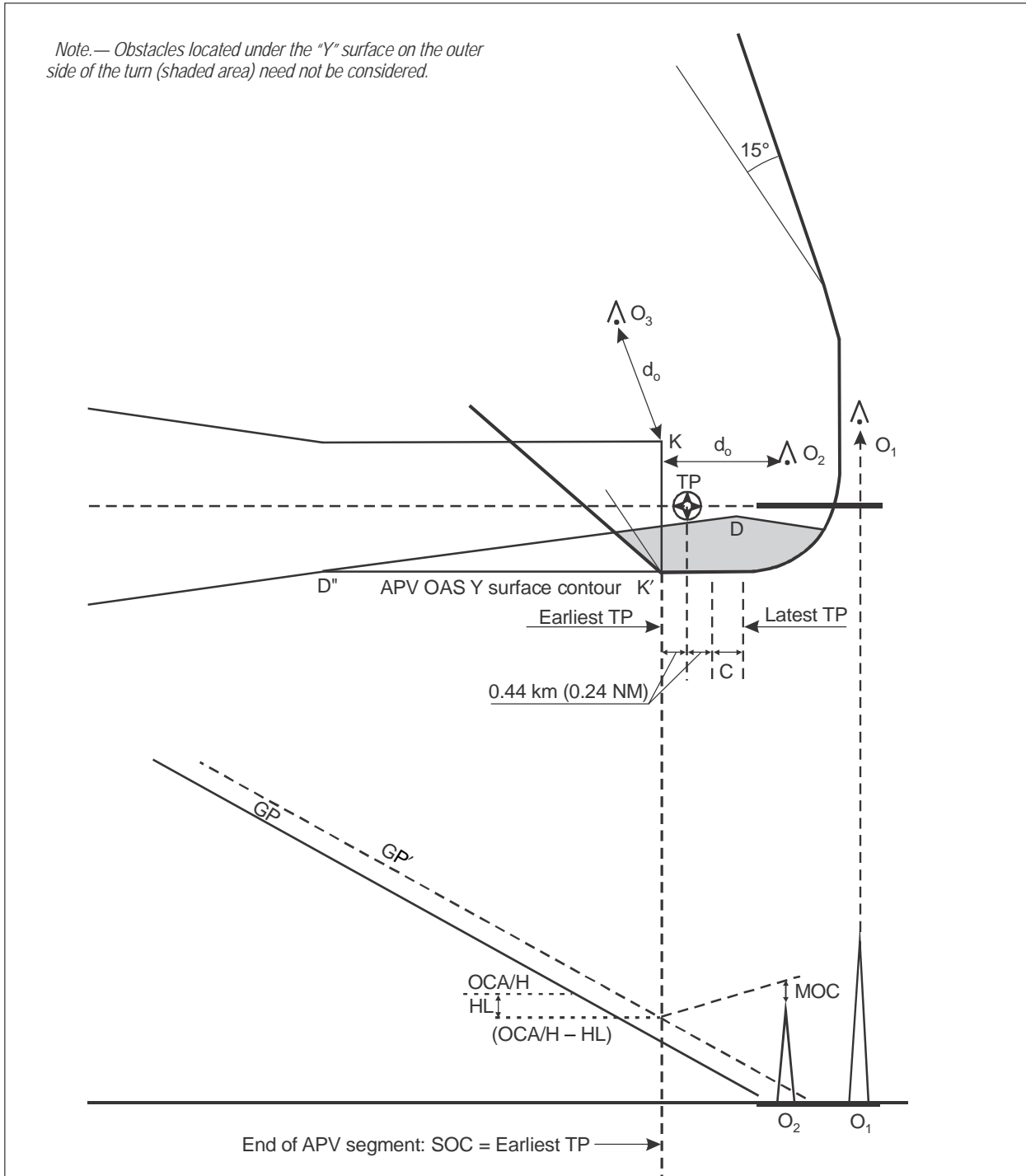

Figure III-3-5-11. Turn at designated TP (flyover waypoint) before the threshold

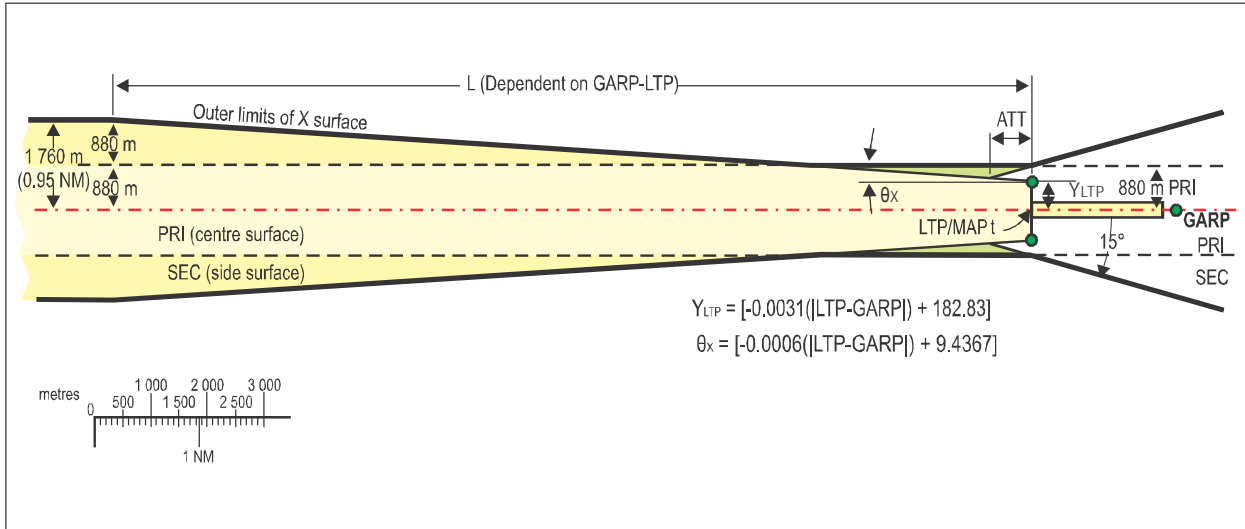

Figure III-3-5-12. Final approach segment with MAPt at LTP (LP)

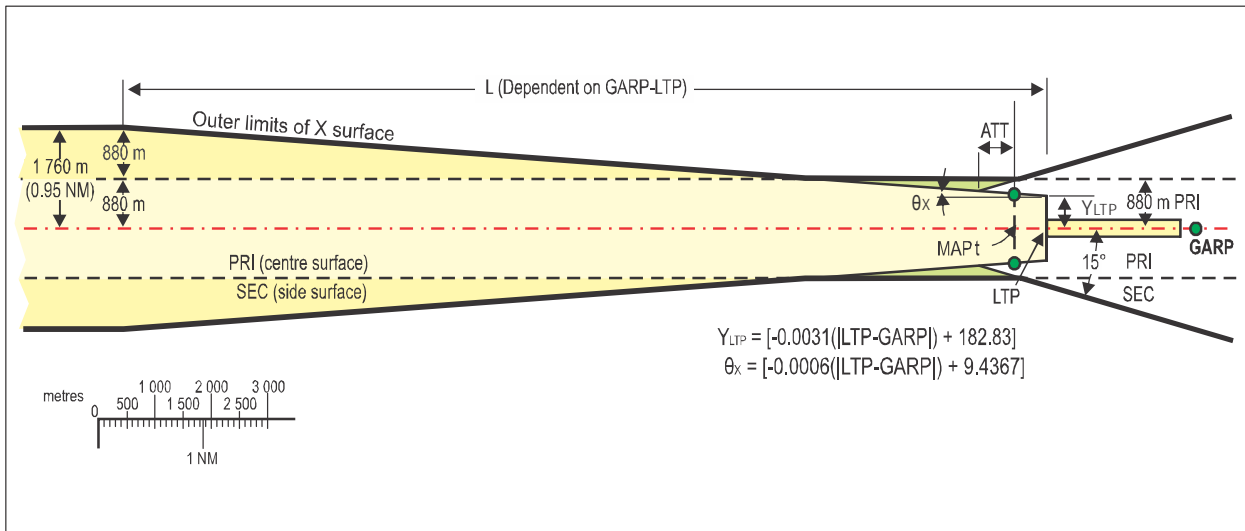

Figure III-3-5-13. Final approach segment with MAPt prior to LTP (LP)

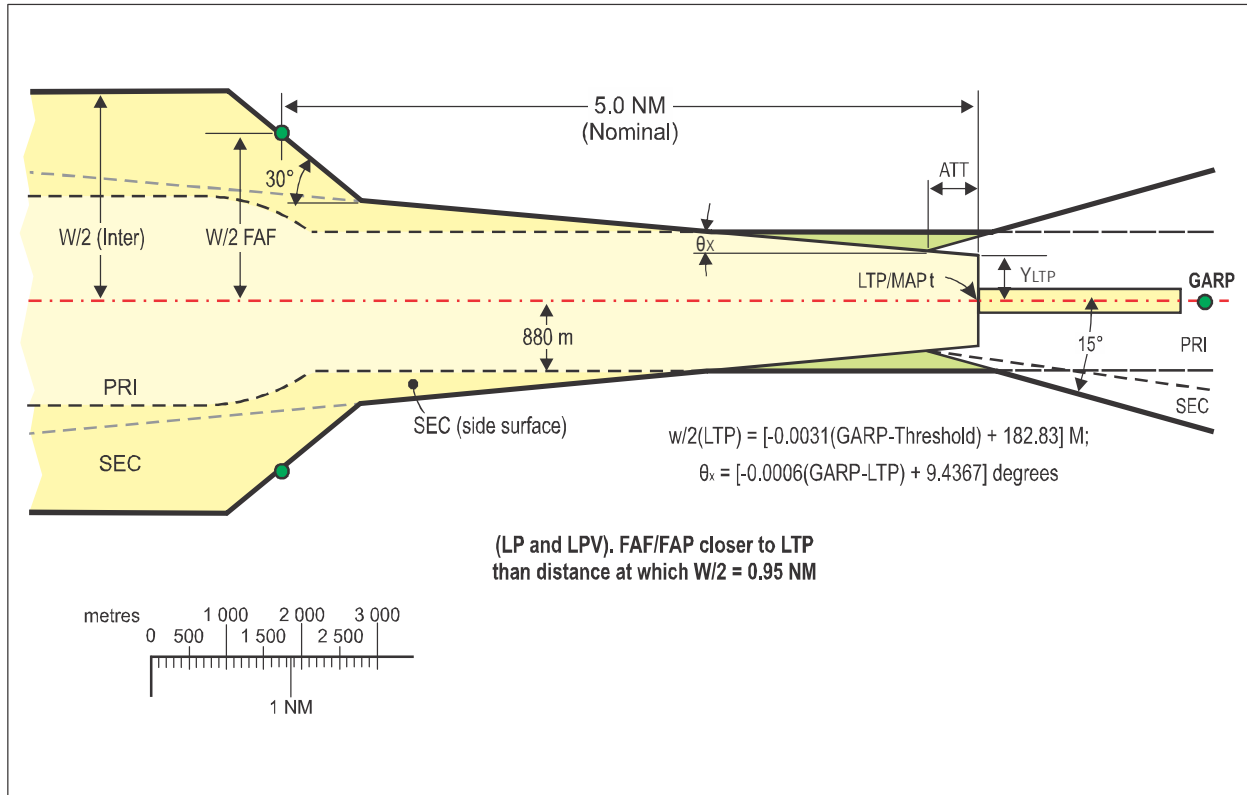

Figure III-3-5-14. Intermediate segment connecting to final segment

Appendix to Chapter 5

STEEP GLIDE PATH ANGLE APPROACHES UP TO 6.3 DEGREES (11 per cent)

1. GENERAL

1.1 For fixed-wing aircraft, glide path angles above the standard values (see 5.1) should be used in approach procedure design only for obstacle clearance purposes and must not be used as a means to introduce noise abatement procedures. Such procedures are non-standard and require special approval.

1.2 The use of the APV SBAS criteria in this appendix is limited to procedures with a glide path angle smaller than or equal to 6.3° (11 per cent).

2. PROCEDURE DESIGN

2.1 Obstacle clearance criteria

The following obstacle clearance criteria should be adjusted for the specific glide path angle:

- a) the W and W' surfaces of the SBAS APV OAS;
- b) origin of the Z surface of the SBAS APV OAS; and
- c) height loss/altimeter margin (see paragraph 3).

2.2 Determination of the SBAS APV OAS coefficients

- *W surface*: Coefficient A_W is determined by the formula

$$A_W = 0.0239 + 0.0092 (\theta - 2.5)$$

in which θ is the glide path angle in degrees.

$$\text{Coefficient } C_W = -6.45$$

- *W' surface*: Coefficients $A_{W'}$ and $C_{W'}$ are determined by the formula

$$A_{W'} = \tan(0.75\theta)$$

$$C_{W'} = -50 + \text{RDH} \tan(0.75\theta)/\tan(\theta) \text{ for APV I and } C_{W'} = -20 + \text{RDH} \tan(0.75\theta)/\tan(\theta) \text{ for APV II}$$

where

RDH = reference datum height (m)

θ = glide path angle

- *X and Y surfaces*: The X and Y surface coefficients for 3.5° glide path at the appropriate GARP/threshold distance are used for all glide path angles greater than 3.5°.
- *Z surface*: The coefficient C_z for the Z surface is determined by the formula

$$C_z = -A_z X_E$$

where A_z is the A coefficient for the selected missed approach gradient; and X_E is the new coordinate of the Z surface origin:

$$X_E = - [900 + (38/\tan\theta) + 50(\theta-3.5^\circ)/0.1^\circ] \text{ for APV I and}$$

$$X_E = - [900 + (8/\tan\theta) + 50 (\theta-3.5^\circ)/0.1^\circ] \text{ for APV II}$$

$$\text{For Cat H, } X_E = - [700 + (38/\tan\theta) + 50(\theta-3.5^\circ)/0.1^\circ] \text{ for APV I and}$$

$$X_E = - [700 + (8/\tan\theta) + 50(\theta-3.5^\circ)/0.1^\circ] \text{ for APV II.}$$

2.3 Determination of the height of equivalent approach obstacle

Use the formula:

$$h_a = [h_{ma} \cot Z + (x - X_E)] / (\cot Z + \cot \theta)$$

where

h_a = height of equivalent approach obstacle

h_{ma} = height of missed approach obstacle

θ = glide path angle

Z = angle of missed approach surface

X_E = new coordinate of the Z surface origin

x = range of obstacle relative to threshold (negative after threshold).

2.4 Re-survey of obstacles

As the configuration of the SBAS APV OAS is changed, a re-survey of obstacles may be required.

2.5 Promulgation

A special note shall be included on the instrument approach chart stating that appropriate aircraft and crew qualifications are required to use such a procedure (see Annex 4, 11.10.8.8).

3. HEIGHT LOSS MARGIN AND OTHER CONSIDERATIONS

3.1 Height loss margins for glide paths greater than 3.5°

The height loss margin can be obtained by extrapolation from the formulas in Part II, Section 1, Chapter 1, 1.4.8.8.3.1 and Chapter 3, 3.4.8.8.3.1, both entitled “Height loss (HL)/altimeter margins”. However, this extrapolation may not be valid for glide paths greater than 3.5° or less than 3.5° when the nominal rate of descent (V_{at} for the aircraft type multiplied by the sine of the glide path angle) exceeds 5 m/s (1 000 ft/min), unless certification on flight trials has verified the effects of:

- a) minimum drag configuration;
- b) wind shear;
- c) control laws;
- d) handling characteristics;
- e) minimum power for anti-icing;
- f) GPWS modification;
- g) use of flight director/autopilot;
- h) engine spin-up time; and
- i) V_{at} increase for handling considerations.

3.2 Additional operational considerations for height loss margin

In addition, the height loss margin may be inadequate unless operational consideration is given to configuration, engine-out operation, maximum tailwind — minimum headwind limits, GPWS, weather minima, visual aids and crew qualifications, etc.

Chapter 6

PRECISION APPROACH PROCEDURES — GBAS

6.1 INTRODUCTION

6.1.1 Application

The GBAS criteria in this chapter are based on ILS criteria and are related to the ground and airborne equipment performance and integrity required to meet the CAT I operational objectives described in Annex 10. An illustration of the specific definitions used in this chapter is given in Figure III-3-6-1.

Note 1.— While specific GBAS CAT I criteria are in preparation, the criteria contained in this chapter are based on an ILS CAT I equivalency method. Development of Annex 10 requirements for CAT II and III approaches is in progress; pending their finalization, procedure design criteria will be made available.

Note 2.— GBAS is the ground-based GNSS augmentation system. The ground facility includes GBAS reference receivers, a processor which prepares messages for broadcast and a VHF data broadcast (VDB) system. The VDB is automatically tuned with the selection of the channel number in the range of 20 000 to 39 999.

Note 3.— The sensor minimum operational performance standards are found in RTCA DO-253C or equivalent documents.

Note 4.— For each runway end supported by the system, the minimum CAT I service volume is described in Annex 10, Volume I, Chapter 3, 3.7.3.5.3 and Attachment D, Chapter 7, 7.3 and Figure D-4.

6.1.2 Procedure construction

The procedure from en route to the GBAS final approach segment and in the final missed approach phase conforms with the general criteria. The differences are found in the physical requirements for the GBAS precision segment which contains the final approach segment as well as the initial and intermediate phases of the missed approach segment. These requirements are related to the performance of the GBAS Cat I system.

6.1.3 Standard conditions

The following list contains the standard assumptions on which procedures are developed. Provisions are made for adjustments where appropriate. Adjustments are mandatory when conditions differ adversely from standard conditions and are optional when so specified (see 6.4.8.7, “Adjustment of OAS constants”).

- a) Maximum aircraft dimensions are assumed to be the following:

<i>Aircraft category</i>	<i>Wing span</i>	<i>Vertical distance between the flight paths of the wheels and the GBAS antenna (m)</i>
H	30	3
A, B	60	6
C, D	65	7
D _L	80	8

Note 1.— OCA/H for Cat D_L aircraft is published when necessary.

Note 2.— The dimensions shown are those which encompass current aircraft types They are chosen to facilitate OCA/H calculations and promulgation of aircraft category related minima. It is assumed that these dimensions are not intended to be used for other purposes than the OCA/H calculations in other ICAO documents. The use of OAS surfaces to calculate OCA/H may result in significant differences between aircraft categories because of small differences in size. For this reason, it is always preferable to use the Collision Risk Model (6.4.9) which will allow for more realistic assessment for both height and position of obstacles.

Note 3.— Current Category E aircraft are not normally civil transport aircraft and their dimensions are not necessarily related to V_{at} at maximum landing mass. For this reason, they should be treated separately on an individual basis.

- b) Missed approach climb gradient: 2.5 per cent.
- c) GBAS course width: 210 m at threshold.
- d) Glide path angle:
- 1) minimum/optimum: 3.0°;
 - 2) maximum: 3.5°;
- e) GBAS reference datum height: 15 m (50 ft).
- f) All obstacle heights are referenced to threshold elevation. A declaration by the procedure designer shall be made for the value of undulation (N) at each runway threshold.
- g) The delta length offset is zero.

6.1.3.1 *Final approach segment (FAS) data.* The final approach segment is defined by data prepared by the procedure designer. The accuracy of the path is therefore totally dependent on the accuracy and integrity of the original data on the runway and calculations carried out by the designer. The total description of the path, including the glide-path, lateral guidance sector width, alignment and all other parameters describing the path are originated by the designer and are not affected by the location of ground facilities. The path parameters are designed using geodetic and geometric calculations and the parameters are formatted into a FAS data block in electronic media as described in the appendix to this chapter. Data are then added to provide a cyclic redundancy check (CRC), and the complete block is

transferred to users to insure the integrity of the data throughout the process leading to inclusion of the path data in the GBAS system for transmission to user airborne systems. A complete description of the FAS data block is included in Doc 9368, *Instrument Flight Procedures Construction Manual*, Attachment C.5, along with an example of the process and product.

6.1.4 Obstacle clearance altitude/height (OCA/H)

The GBAS criteria enable an OCA/H to be calculated for each category of aircraft. See Part I, Section 4, Chapter 1, 1.8, “Categories of aircraft”. Where statistical calculations were involved, the OCA/H values were designed against an overall safety target for risk of collision with obstacles of 1×10^{-7} , i.e. 1 in 10 million per approach. The OCA/H ensures clearance of obstacles from the start of the final approach to the end of the intermediate missed approach segment.

Note.— This OCA/H is only one of the factors to be taken into account in determining decision height as defined in Annex 6.

6.1.5 Methods of calculating OCA/H

6.1.5.1 *General.* Three methods of calculating OCA/H are presented, which in turn involve progressive increases in the degree of sophistication in the treatment of obstacles. Standard conditions (as specified in 6.1.3) are assumed to exist unless adjustments for non-standard conditions have been made.

6.1.5.2 *First method.* The first method involves a set of surfaces derived from the Annex 14 precision approach obstacle limitation surfaces and a missed approach surface described in 6.4.7.2, “Definition of basic ILS surfaces” and from this point forward termed “Basic ILS surfaces”. Where the standard conditions exist as specified in 6.1.3 and where the basic ILS surfaces are free of penetrations (see 6.4.7.1, “General”) the OCA/H for Cat I is defined by aircraft category margins. If the basic ILS surfaces are penetrated, then the OCA/H is calculated as described in 6.4.7.3, “Determination of OCA/H with basic ILS surfaces”.

6.1.5.3 *Second method.* The second method involves a set of obstacle assessment surfaces (OAS) above the basic ILS surfaces (see 6.4.8.3, “Definition of obstacle assessment surfaces (OAS)”). If the OAS are not penetrated, and provided the obstacle density below the OAS is operationally acceptable (see 6.4.8.9, “Effect of obstacle density on OCA/H”), the OCA/H for Cat I is still defined by the aircraft category margins. However, if the OAS are penetrated, then the aircraft category related margin is added to the height of the highest approach obstacle, or to the adjusted height of the largest missed approach penetration, whichever is greater. This value becomes the OCA/H.

6.1.5.4 *Third method.* The third method, using a collision risk model (CRM), is employed either as an alternative to the use of the OAS criteria (second method) or when the obstacle density below the OAS is considered to be excessive. The CRM accepts all objects as an input and assesses, for any specific OCA/H value, both the risk due to individual obstacles and the accumulated risk due to all the obstacles. It is intended to assist operational judgement in the choice of an OCA/H value.

Note 1.— While specific GBAS distributions for the existing CRM are being developed, use should be made of the current ILS CRM.

Note 2.— The CRM does not take into account the characteristics of helicopters. The CRM can be used but the method should be conservative.

6.1.6 References

The following relate to and amplify the material contained in this chapter:

- a) background information relating to the derivation of the OAS material (Attachment to Part II, paragraph 1) and to airborne and ground equipment performance assumed in the derivation of the OAS (paragraph 2);
- b) turning missed approach after precision approach (Part II, Section 1, Chapter 1, Appendix A);
- c) independent parallel approaches to closely spaced parallel runways (Part II, Section 1, Chapter 1, Appendix D);
- d) determining ILS glide path descents/MLS elevation heights and distances (Part II, Section 1, Chapter 1, Appendix C); and
- e) PANS-OPS OAS software (ICAO public website (www.icao.int) under “Publications”).

Examples of OCA/H calculations can be found in the *Instrument Flight Procedures Construction Manual* (Doc 9368).

6.2 INITIAL APPROACH SEGMENT

6.2.1 General

The initial approach segment for GBAS must ensure that the aircraft is positioned within the operational service volume of the GBAS on a track or heading that will facilitate final approach course interception. For this reason, the general criteria, which apply to the initial segment (see Chapter 2), are modified in accordance with 6.2.2, “Alignment” and 6.2.3, “Area”. The initial approach segment may be defined by an RNAV or RNP route, using an RNAV or RNP system for track guidance. Only the systems capable of navigation accuracy of 1 NM or better in this phase of flight can be considered. Refer to Part III, Section 1, Chapter 1, Table III-1-1-1 for the navigation specifications that can be used for initial approach. The RNAV or RNP route shall terminate at an IF defined by RNAV or RNP located on the final approach course. RNAV/RNP turn construction is applicable for turns within the initial segment and for the turn at the IF on the final approach course (see Figures III-3-6-4 and III-3-6-5). For RNAV and RNP initial approach segments, criteria in Part III apply. If a course reversal is required with an RNAV or RNP initial approach segment, only a racetrack can be used. The fix and the inbound leg shall be located on the final approach course and the inbound segment defined by GBAS.

6.2.2 Initial approach segment alignment

The angle of interception between the initial approach track and the intermediate track should not exceed 90°. In order to permit the auto pilot to couple on to the final approach course, an interception angle not exceeding 30° is desirable. When the angle exceeds 70° a radial, bearing, radar vector, DME information providing at least 4 km (2 NM) (CAT H, 1.9 km (1 NM)) of lead shall be identified to assist the turn onto the intermediate track. When the angle exceeds 90°, the use of a reversal, racetrack, or dead reckoning (DR) track procedure (see Part I, Section 4, Chapter 3, Appendix A, “Initial approach using dead reckoning (DR)”) should be considered.

6.2.3 Initial approach segment area

The area is as described in the general criteria (see Part I) The only exception to these criteria is that the intermediate approach fix (IF), must be located within the service volume of the GBAS, and normally at a distance not exceeding

37 km (20 NM) from the landing threshold point (LTP). When radar is used to provide track guidance to the IF, the area shall be in accordance with Part II, Section 2, Chapter 6, 6.2, “Initial approach segment”.

6.3 INTERMEDIATE APPROACH SEGMENT

6.3.1 General

6.3.1.1 The intermediate approach segment for GBAS differs from the general criteria in that:

- a) the alignment coincides with the final approach course;
- b) the length may be reduced; and
- c) in certain cases the secondary areas may be eliminated.

6.3.1.2 The primary and secondary areas at the FAP are defined in terms of the ILS surfaces. Consequently, the criteria in Chapter 5 are applied except as noted for alignment, area length, width and obstacle clearance in 6.3.2 through 6.3.5 below. For RNAV intermediate approach segments, the criteria in the applicable RNAV chapters apply.

6.3.2 Intermediate approach segment alignment

The intermediate approach segment of a GBAS procedure shall be aligned with the final approach course.

6.3.3 Intermediate approach segment length

6.3.3.1 The optimum length of the intermediate approach segment is 9 km (5 NM) (Cat H, 3.7 km (2.0 NM)). This segment shall allow interception with the final approach course and with the glide path.

6.3.3.2 The segment length should be sufficient to permit the aircraft to stabilize and establish on the final approach course prior to intercepting the glide path, taking into consideration the angle of interception with the final approach course.

6.3.3.3 Minimum values for distance between final approach and interception of the glide path are specified in Table III-3-6-1; however, these minimum values should only be used if usable airspace is restricted. The maximum length of the segment is governed by the requirement that it be located wholly within the service volume of the GBAS, and normally at a distance not exceeding 37 km (20 NM) from the landing threshold point (LTP).

6.3.4 Intermediate approach segment area width

6.3.4.1 The total width at the beginning of the intermediate approach segment is defined by the total width of the initial approach segment and tapers uniformly to match the horizontal distance between the OAS X surfaces at the FAP (see 6.4.8.3, “Definition of OAS”).

6.3.4.2 For obstacle clearance purposes the intermediate approach segment is divided into a primary area bounded on each side by a secondary area. However, when a DR track is used in the initial approach segment, the primary area of the intermediate segment extends across the full width and secondary areas are not applied.

6.3.4.3 The primary area is determined by joining the primary initial approach area with the final approach surfaces (at the FAP). At the interface with the initial approach segment the width of each secondary area equals half the width of the primary area. The secondary area width decreases to zero at the interface with the final approach surfaces. See Figure III-3-6-2.

6.3.4.4 Where a racetrack or reversal manoeuvre is specified prior to intercepting the final approach course, the provisions in Part I, Section 4, Chapter 4, 4.4.4, “Turn not at the facility” apply, the facility being the GARP itself and the FAF being replaced by the FAP. (See Figure III-3-6-3).

6.3.5 Intermediate approach segment obstacle clearance

The obstacle clearance is the same as defined in Part I, Section 4, Chapter 4, except where the procedure permits a straight-in approach in which the aircraft is stabilized on the final approach course prior to crossing the IF. In this case, obstacles in the secondary areas need not be considered for the purpose of obstacle clearance.

6.4 PRECISION SEGMENT

6.4.1 General

The precision segment for GBAS is aligned with the final approach course and contains the final descent for landing, the initial and the intermediate missed approach. See Figure III-3-6-6.

6.4.2 Origin

The precision segment starts at the final approach point, that is the intersection of the nominal glide path and the minimum altitude specified for the preceding segment. The FAP should not normally be located more than 18.5 km (10.0 NM) before threshold, unless adequate glide path guidance beyond the minimum specified in Annex 10 is provided.

6.4.3 Glide path verification check

A fix at the FAP is necessary so as to permit comparison between the indicated glide path and the aircraft altimeter information.

6.4.4 Descent fix

A descent fix shall be located to start the final approach segment and it becomes the final approach point linking the MOC in the preceding segment smoothly with the precision surfaces. The descent fix should not normally be located more than 18.5 km (10.0 NM) before threshold, unless adequate glide path guidance beyond the minimum specified in Annex 10 is provided. The tolerance of the descent fix does not need to be considered due to accuracy.

Note.— Guidance material for determining the distance to the descent fix from the landing threshold is contained in Part II, Section 1, Chapter 1, Appendix C.

6.4.4.1 The provisions of Part I, Section 2, Chapter 2, 2.7.4 which allow obstacles close to the fix to be ignored, apply in the area below the 15 per cent gradient within the precision surfaces.

6.4.5 Missed approach

The missed approach shall be initiated no lower than the intersection of the nominal glide path with the decision altitude/height (DA/H). The DA/H is set at or above the OCA/H, which is determined as specified in 6.4.7 to 6.4.9 and 6.5.

6.4.6 Termination

The precision segment normally terminates at the point where the final phase of the missed approach commences (see Part I, Section 4, Chapter 6, 6.2.3, “Final phase”) or where the missed approach climb surface Z starting 900 m past threshold reaches a height of 300 m (1 000 ft) above threshold, whichever is lower.

6.4.7 Obstacle clearance of the precision segment using basic ILS surfaces for GBAS operations

6.4.7.1 *General.* The area required for the precision segment is bounded overall by the basic ILS surfaces defined in 6.4.7.2. In standard conditions there is no restriction on objects beneath these surfaces (see 6.1.3, “Standard Conditions”). Objects or portions of objects that extend above these surfaces must be either:

- a) minimum mass and frangible; or
- b) taken into account in the calculation of the OCA/H.

6.4.7.2 *Definition of basic ILS surfaces.* The surfaces to be considered correspond to a subset of Annex 14 obstacle limitation surfaces specified for precision approach runway code numbers 3 or 4. These are (see Figure III-3-6-7):

- a) the approach surface continuing to the final approach point (first section 2 per cent gradient, second section 2.5 per cent gradient as described in Annex 14);
- b) the runway strip assumed to be horizontal at the elevation of the threshold;
- c) the missed approach surface. This is a sloping surface which:
 - 1) starts at a point 900 m past the threshold (Cat H, a starting point of 700 m past the threshold can be considered if necessary) at threshold elevation;
 - 2) rises at a 2.5 per cent gradient; and
 - 3) splays so as to extend between the transitional surfaces. It extends with constant splay to the level of the inner horizontal surface, and thereafter, continues at the same gradient but with a 25 per cent splay until the termination of the precision segment; and
- d) the extended transitional surfaces, which continue longitudinally along the sides of the approach and missed approach surfaces and to a height of 300 m above threshold elevation.

6.4.7.3 *Determination of OCA/H with basic ILS surfaces.*

6.4.7.3.1 Where the basic ILS surfaces specified in 6.4.7.2 are not penetrated, the OCA/H for Category I is defined by the margins specified in Table III-3-6-3. Obstacles may be excluded when they are below the transitional

surface defined by Annex 14 for runways with code numbers 3 and 4, regardless of the actual runway code number (i.e., the surfaces for code numbers 3 and 4 are used for the obstacle assessment on runways with code numbers 1 and 2).

6.4.7.3.2 If the basic ILS surfaces listed above are penetrated by objects other than those tabulated in Table III-3-6-2 the OCA/H may be calculated directly by applying height loss/altimeter margins to obstacles (see 6.4.8.8). The obstacles in Table III-3-6-2 may only be exempted if the GBAS course width meets the standard condition of 210 m (see 6.1.3).

6.4.7.3.3 An object which penetrates any of the basic ILS surfaces and becomes the controlling obstacle, but which must be maintained because of its function with regard to air navigation requirements, may be ignored under certain circumstances in calculating the OCA/H, with the following provision. It must be established by the appropriate authority that the portion which penetrates the surface is of minimum mass and frangibly mounted and would not adversely affect the safety of aircraft operations.

6.4.8 Obstacle clearance of the precision segment using obstacle assessment surfaces (OAS) criteria for GBAS operations

6.4.8.1 General

6.4.8.1.1 This section describes the OAS surfaces, the constants which are used to define these surfaces, and the conditions under which adjustments may be made. The OAS dimensions are related to the GBAS geometry (GARP – LTP distance, glide path angle), and the category of operation. (For GBAS only Category I apply). A table of OCA/H values for each aircraft category may be promulgated for GBAS Cat I operations at the particular airfield.

6.4.8.1.2 Additional material is included to enable appropriate authorities to assess realistic benefits for claims of improved performance and associated conditions (see 6.4.8.7, “Adjustment of OAS constants”).

6.4.8.1.3 Note that the OAS are not intended to replace Annex 14 surfaces as planning surfaces for unrestricted obstacle growth. The obstacle density between the basic ILS surfaces and the OAS must be accounted for (see 6.4.8.9, “Effect of obstacle density on OCA/H”).

6.4.8.2 Frame of reference

Positions of obstacles are related to a conventional x, y, z coordinate system with its origin at threshold. See Figure III-3-6-11. The x-axis is parallel to the precision segment track, positive x coordinates measured before landing threshold and negative x coordinates measured after landing threshold. The y-axis is at right angles to the x-axis. Although shown conventionally in Figure III-3-6-11, *in all calculations associated with OAS geometry, the y-coordinate is always counted as positive*. The z-axis is vertical, heights above threshold being positive. All dimensions connected with the OAS are specified in metres only. The dimensions should include any adjustments necessary to cater for tolerances in survey data (see Part I, Section 2, Chapter 1, 1.8).

6.4.8.3 Definition of obstacle assessment surfaces (OAS)

6.4.8.3.1 The OAS consist of six sloping plane surfaces (denoted by letters W, X, Y, and Z) arranged symmetrically about the precision segment track, together with the horizontal plane which contains the threshold (see Figures III-3-6-9 and III-3-6-10). The geometry of the sloping surfaces is precisely defined by four simple linear equations of the form $z = Ax + By + C$. In these equations x and y are position coordinates and z is the height of the surface at that position (see Figure III-3-6-8).

6.4.8.3.2 For each surface a set of constants A, B and C are obtained from PANS-OPS OAS software for the operational range of GARP-threshold distances and glide path angles. These constants may be modified as specified in 6.4.8.7, “Adjustment of OAS constants”.

6.4.8.3.3 The Category I OAS are limited by the length of the precision segment and, except for the W and X surfaces, by a maximum height of 300 m.

6.4.8.3.4 Where the Annex 14 approach and transitional obstacle limitation surfaces for code numbers 3 and 4 precision approach runways penetrate inside the OAS, the Annex 14 surfaces become the OAS (i.e. the surfaces for code numbers 3 and 4 are used for obstacle assessment on runways with code numbers 1 and 2). The Annex 14 inner approach, inner transitional and balked landing obstacle limitation surfaces protect Category III operations provided the Category II OCA/H is at or below the top of those surfaces, which may be extended up to 60 m if necessary (see Figure III-3-6-7).

6.4.8.4 OAS constants – specification

For Category I operations the constants A, B and C for each sloping surface are obtained from the PANS-OPS OAS software. The PANS-OPS OAS software gives coefficients for glidepath angles between 2.5 and 3.5 degrees in 0.1 degree steps, and for any GARP-LTP distance between 2 000 m and 4 500 m. Extrapolation outside these limits is not permitted. If a GARP-LTP distance outside this range is entered, the PANS-OPS software gives the coefficients for 2 000 m or 4 500 m as appropriate, which must be used. For an example of the PANS-OPS OAS software results see Figure III-3-6-13.

6.4.8.5 Calculation of OAS heights

To calculate the height z of any of the sloping surfaces at a location x' , y' , the appropriate constants should be first obtained from the PANS-OPS OAS software. These values are then substituted in the equation $z = Ax' + By' + C$. If it is not clear which of the OAS surfaces is above the obstacle location, this should be repeated for the other sloping surfaces. The OAS height is the highest of the plane heights (zero if all the plane heights are negative).

Note.— The PANS-OPS OAS software also contains an OCH calculator that will show the height of OAS surface Z above any X, Y location. It includes all the adjustments specified for ILS geometry, aircraft dimensions, missed approach climb gradient and GBAS RDH.

6.4.8.6 OAS template construction

Templates, or plan views of the OAS contours to map scale, are sometimes used to help identify obstacles for detail survey (see Figure III-3-6-12). The OAS data on the PANS-OPS OAS software includes the coordinates of the points of intersection of the sloping surfaces at threshold level and at 300 m above threshold level for Cat I (see Figure III-3-6-13). The intersection coordinates at threshold level are labelled as C, D and E.

6.4.8.7 Adjustment of OAS constants

6.4.8.7.1 *General.* The following paragraphs describe the adjustments which may be made to the OAS constants. These adjustments are mandatory when the standard conditions are not met (See 6.1.3, “Standard conditions”). Optional adjustments may be made when so specified. For examples of calculations see the *Instrument Flight Procedures Construction Manual* (Doc 9368).

6.4.8.7.2 *Reasons for adjusting constants.* The constants may be modified by the PANS-OPS OAS software to account for the following:

- a) dimensions of specific aircraft;
- b) the height of the GBAS DCP;
- c) GBAS course width greater than 210 m at threshold; and
- d) missed approach climb gradient.

6.4.8.7.3 *Specific aircraft dimensions.* An adjustment is mandatory where aircraft dimensions exceed those specified in 6.1.3, “Standard conditions” and is optional for aircraft with smaller dimensions. The PANS-OPS OAS software adjusts the OAS coefficients and template coordinates for the standard dimensions of category A, B, C, D, and D_L aircraft automatically. It will do the same for specific aircraft dimensions in any category. It uses the following correction formula to adjust the coefficient C for the W, W*, X and Y surfaces:

$$W \text{ surface: } C_{w\text{corr}} = C_w - (t - 6)$$

$$W^* \text{ surface: } C_{w^*\text{corr}} = C_{w^*} - (t - 6)$$

$$X \text{ surface: } C_{x\text{corr}} = C_x - B_x \times P$$

$$Y \text{ surface: } C_{y\text{corr}} = C_y - B_y \times P$$

where:

$P = [t/B_x \text{ or } s + (t-3)/B_x], \text{ whichever is the maximum}] - [6/B_x \text{ or } 30 + 3/B_x, \text{ whichever is the maximum}];$ and

s = semi-span

t = vertical distance between paths of the GP antenna and the lowest part of the wheels.

6.4.8.7.4 *Height of the datum crossing point (RDH).* The constants are based on a reference datum height (RDH) of 15 m. An adjustment to the OAS constants is mandatory for an RDH less than 15 m, and is optional for an RDH greater than 15 m. The PANS-OPS OAS software adjusts the OAS coefficients and template co-ordinates by correcting the tabulated values of the coefficient C for the W, W*, X and Y surfaces as follows:

$$C_{\text{corr}} = C + (\text{RDH} - 15)$$

where: C_{corr} = corrected value of coefficient C for the appropriate surface

C = tabulated value.

6.4.8.7.5 *GBAS course width greater than 210 m at threshold.* Where the GBAS course width at threshold is greater than the nominal value of 210 m, the collision risk model (CRM) method described in 6.4.9 shall be used. Adjustments for sector widths less than 210 m shall not be made, and are inhibited on the PANS-OPS OAS software.

6.4.8.7.6 *Missed approach gradient.* If missed approach climb gradients better than the nominal 2.5 per cent can be achieved, the Y and Z surfaces may be adjusted. This is done by selecting the desired missed approach climb gradient in the PANS-OPS OAS software. The programme then adjusts the Y and Z surface constants.

6.4.8.8 *Determination of OCA/H with OAS*

6.4.8.8.1 *General.* The OCA/H is determined by accounting for all obstacles which penetrate the basic ILS surfaces defined in 6.4.7.2 and the OAS applicable to the GBAS Category I operation being considered. The exemptions listed in 6.4.7.3, “Determination of OCA/H with basic ILS surfaces” for obstacles penetrating the basic ILS surfaces may be applied to obstacles penetrating the OAS, providing the criteria listed in that paragraph are met. For GBAS Category I operations ILS Cat I OAS apply.

6.4.8.8.2 *Calculation of OCA/H values with OAS.* Accountable obstacles, as determined below in 6.4.8.8.2.1, “OCA/H calculation steps”, are divided into approach and missed approach obstacles. The standard method of categorization is as follows. Approach obstacles are those between the FAP and 900 m after threshold (Cat H, 700 m if necessary). Missed approach obstacles are those in the remainder of the precision segment (see Figure III-3-6-14). However, in some cases this categorization may produce an excessive penalty for certain missed approach obstacles (see Attachment to Part II, 1.9). Where desired by the appropriate authority, missed approach obstacles may be defined as those above a plane surface parallel to the plane of the glide path and with origin at -900 m (Cat H, -700 m if necessary) (see Figure III-3-6-15), i.e. obstacle height greater than $(900 + x) \tan \theta$.

6.4.8.8.2.1 *OCA/H calculation steps*

- a) Determine the height of the highest approach obstacle.
- b) Convert the heights of all missed approach obstacles (h_{ma}) to the heights of equivalent approach obstacles (h_a) by the formula given below, and determine the highest equivalent approach obstacle.
- c) Determine which of the obstacles identified in steps a) and b) is the highest. This will give the controlling obstacle.
- d) Add the appropriate aircraft category related margin (Table III-3-6-3) to the height of the highest controlling obstacle.

$$h_a = \frac{h_{ma} \cot Z + (-x_z + x)}{\cot Z + \cot \theta}$$

- where:
- h_a = height of equivalent approach obstacle
 - h_{ma} = height of missed approach obstacle
 - θ = glide path angle
 - Z = angle of missed approach surface
 - x = range of obstacle relative to landing threshold point (negative after LTP)
 - x_z = distance from threshold to origin of Z surface (-900 m, -700 m for Cat H)

6.4.8.8.3 *Adjustments for high airfield elevations and steep glide path angles.*

6.4.8.8.3.1 The margins shall be adjusted as follows:

- a) for airfield elevation higher than 900 m (2 953 ft), the allowances shall be increased by 2 per cent of the radio altimeter margin per 300 m (1 000 ft) airfield elevation; and

- b) for glide path angles greater than 3.2° in exceptional cases, the allowances shall be increased by the 5 per cent of the radio altimeter margin per 0.1° increase in glide path angle between 3.2° and 3.5°.

6.4.8.8.3.1.1 Procedures involving glide paths greater than 3.5° or any angle when the nominal rate of descent (V_{at} for the aircraft type \times the sine of the glide path angle) exceeds 5 m/sec (1 000 ft/min), are non-standard. They require the following:

- a) increase of height loss margin (which may be aircraft type specific);
- b) adjustment of the origin of the missed approach surface;
- c) adjustment of the slope of the W surface;
- d) re-survey of obstacles; and
- e) the application of related operational constraints.

Such procedures are normally restricted to specifically approved operators and aircraft, and are associated with appropriate aircraft and crew restrictions. They are not to be used as a means to introduce noise abatement procedures.

6.4.8.8.3.1.2 Part II, Section 1, Chapter 1, Appendix B shows the procedure design changes required and the related operational/certification considerations.

Example: Aircraft Category C — Aerodrome elevation:

1 650 m above MSL; glide path angle 3.5°

Tabulated allowances: radio altimeter 22 m

(Table III-3-6-3) pressure altimeter 46 m

Correction for aerodrome elevation:

$$22 \times 2/100 \times 1\,650/300 = 2.42 \text{ m}$$

Correction for glide path angle:

$$22 \times 5/100 \times (3.5-3.2)/0.1 = 3.30 \text{ m}$$

Total correction 5.72 m rounded up to 6 m

Corrected radio altimeter margin $22 + 6 = 28 \text{ m}$

Corrected pressure altimeter margin $46 + 6 = 52 \text{ m}$

6.4.8.8.3.2 *Exceptions and adjustments to values in Table III-3-6-3.* Values in Table III-3-6-3 are calculated to account for aircraft using normal manual overshoot procedures from OCA/H on the nominal approach path. The values do not consider the lateral displacement of an obstacle nor the probability of an aircraft being so displaced. If consideration of these joint probabilities is required, then the CRM discussed in 6.4.9 shall be used. Values in Table III-3-6-3 may be adjusted for specific aircraft types where adequate flight and theoretical evidence is available, i.e. the height loss value corresponding to a probability of 1×10^{-5} (based on a missed approach rate 10^{-2}).

6.4.8.8.3.3 *Radio altimeter verification.* If the radio altimeter OCA/H are promulgated, operational checks shall have confirmed the repeatability of radio altimeter information.

6.4.8.8.3.4 *Height loss (HL)/altimeter margins for a specific speed at threshold.* If a height loss/altimeter margin is required for a specific V_{at} , the following formulae apply (see also Table III-3-6-4):

Use of radio altimeter:

Margin = $(0.096 V_{at} - 3.2)$ metres where V_{at} in km/h

Margin = $(0.177 V_{at} - 3.2)$ metres where V_{at} in kt

Use of pressure altimeter:

Margin = $(0.068 V_{at} + 28.3)$ metres where V_{at} in km/h

Margin = $(0.125 V_{at} + 28.3)$ metres where V_{at} in kt

where V_{at} is the speed at threshold based on 1.3 times stall speed in the landing configuration at maximum certificated landing mass.

Note.— *The equations assume the aerodynamic and dynamic characteristics of the aircraft are directly related to the speed category. Thus, the calculated height loss/altimeter margins may not realistically represent small aircraft with V_{at} at maximum landing mass exceeding 165 kt.*

6.4.8.8.3.5 *Height loss (HL)/altimeter margins for a specific speed at threshold (Helicopters).* For helicopter operations the concept of V_{at} is not applicable. Height loss margins are listed in Table III-3-6-3.

6.4.8.9 *Effect of obstacle density on OCA/H.* To assess the acceptability of obstacle density below the OAS, the CRM described in 6.4.9 may be used. This can provide assistance by comparing aerodrome environments and assessing risk levels associated with given OCA/H values. It is emphasized that it is not a substitute for operational judgement.

6.4.9 Obstacle clearance of the precision segment — application of collision risk model (CRM) for GBAS operations

Note.— *A specific GBAS implementation of the CRM is in preparation.*

6.4.9.1 *General.* The ILS CRM is a computer programme that establishes the numerical risk which can be compared to the target level of safety for aircraft operating to a specified OCA/H height. This ILS CRM can be used for GBAS Category I operations while the specific GBAS CRM is in preparation. A description of the ILS CRM programme and instructions on its use, including the precise format of both the data required as input and the output results, are given in the *Manual on the Use of the Collision Risk Model (CRM) for ILS Operations* (Doc 9274).

6.4.9.2 *Input.* The CRM requires the following data as input:

- a) *Aerodrome details:* name, runway threshold position and runway orientation, threshold elevation above MSL, details of preceding segment;
- b) *GBAS parameters:* category (Cat I only), glide path angle, GARP – LTP distance, GBAS course width and height of DCP;
- c) *Missed approach parameters:* decision height/altitude (obstacle clearance height) and missed approach turn point;

- d) *Aircraft parameters*: type, wheel height (antenna to bottom of wheel), and wing semi-span, aircraft category (A, B, C, D or D_L) and missed approach climb gradient; and

Note.— The CRM does not consider Category E aircraft.

- e) *Obstacle data*: obstacle boundaries (either as x and y coordinates relative to the runway threshold or as map grid coordinates) and obstacle height (either above threshold elevation or above MSL). For density assessment, all obstacles penetrating the basic ILS surfaces described in 6.4.7.2 must be included.

6.4.9.3 *Output and application.* The output of the programme is the overall (total) risk of collision with obstacles to the aircraft of operating to the specified OCA/H and through the missed approach. Other information may also be produced using various output options.

6.4.9.3.1 For example, the risks associated with individual obstacles may be given, and these risks can be ordered, either in terms of obstacle range, or more usefully in terms of risk magnitude, so that the user may see at a glance which obstacles are the major contributors to the total risk.

6.4.9.3.2 The user, by rerunning the CRM with the appropriate parameters, can assess the effect on the safety of operations of any alteration in the parameters, typically varying the glide path angle, or increasing/reducing the OCA/H. The computed risk is compared with a pre-specified acceptable level of risk (not worse than 1×10^{-7} per approach) which meets the overall safety target.

6.4.9.4 *Determination of OCA/H.* The determination of OCA/H is a process in which the CRM is successively rerun with changing values of OCA/H until the computed risk meets the target level of safety (i.e. better than 1×10^{-7} per approach).

6.5 MISSED APPROACH AFTER THE PRECISION SEGMENT (FINAL MISSED APPROACH)

6.5.1 General

The criteria for the final missed approach are based on those for the general criteria (see Chapter 7). Certain modifications have been made to allow for the different areas and surfaces associated with the GBAS precision segment and the possible variation in OCA/H for that segment with aircraft category.

6.5.1.1 The datum used for calculation of distances and gradients in obstacle clearance calculations is termed “start of climb” (SOC). It is defined by the height and range at which the plane GP’ (a plane parallel with the glide path and with origin at –900 m (Cat H, –700 m) at threshold level) reaches an altitude OCA/H – HL. Area construction is according to the navigation system specified for the missed approach (where OCA/H and HL both relate to the same category of aircraft).

6.5.1.2 If obstacles identified in the final missed approach segment result in an increase in any of the OCA/H calculated for the precision segment, an additional steeper gradient may also be specified for the missed approach surface (Z) for the purpose of lowering the OCA/H (see Part I, Section 4, Chapter 6, 6.2.2.2, “Climb gradient in the intermediate phase”).

6.5.1.3 Missed approach using an RNAV or RNP system for track guidance can be utilized. Only the systems capable of navigation accuracy of 1 NM or better in this phase of flight can be considered. Refer to Part III, Section 1, Chapter 1, Table III-1-1-1 for the navigation specifications that can be used for missed approach.

6.5.2 Straight missed approach

6.5.2.1 *General.* The precision segment terminates at the range where the Z surface reaches a height 300 m above threshold LTP. The width of the Z surface at that range defines the initial width of the final missed approach area which is developed as shown in Figure III-3-6-16. There are no secondary areas.

6.5.2.2 *Straight missed approach obstacle clearance.* (See Figure III-3-6-17.) Obstacle elevation/height in this final missed approach area shall be less than

$$(OCA/H_{ps} - HL) + d_o \tan Z$$

where:

OCA/H for precision segment (OCA/H_{ps}) and HL (Table III-3-6-3) both relate to the same aircraft category;

d_o is measured from SOC parallel to the straight missed approach track; and

Z is the angle of the missed approach surface with the horizontal plane.

If this requirement cannot be met, a turn shall be prescribed to avoid the obstacle in question. If a turn is not practical, the OCA/H shall be raised.

6.5.2.3 Transition from conventional navigation to an RNAV or RNP missed approach may be defined by an RNAV or RNP fix located on the extended final approach course, or by a turn at an altitude direct to a waypoint (see Figure III-3-6-23). If the RNAV or RNP track is collinear with the azimuth course, the area abeam the SOC shall be expanded at a 15-degree angle from the track course until it reaches the applicable width of the RNAV or RNP area constructed on the extended final approach course. In the region between the lateral boundaries of the Z surface and the outer boundaries of the area, the obstacle evaluation is based on the Y surface and a mathematical extrapolation of the Y surface where the area is outside the lateral boundaries of the OAS 300 m contour. The Z surface shall continue to splay at the same angle until reaching the width of the RNAV or RNP area. Secondary areas shall apply from the point where the width of the Z surface reaches the width of the RNAV or RNP primary area (see Figure III-3-6-21). Obstacle clearance up to this point for the extended Y and Z surfaces shall be the same as in the precision segment (see 1.4.8 “Obstacle clearance of the precision segment using obstacle assessment surface (OAS) criteria”), and this shall also apply further out to all portions of the Z surface that are within the RNAV or RNP primary area. The principle of secondary areas shall apply between the edge of the RNAV or RNP primary area and the edge of the total area. If an obstacle penetrates either the extended Y or the Z surface within the secondary area, its elevation/height shall be less than:

$$(OCA/H_{ps} - HL) + d_o \tan Z + M$$

where:

- a) OCA/H for precision segment (OCA/H_{ps}) and HL (Table III-3-6-3) both relate to the same aircraft category;
- b) d_o is measured from SOC parallel to the straight missed approach track;
- c) Z is the angle of the missed approach surface with the horizontal plane; and
- d) M is zero at the edge of the primary area increasing linearly to 30 m (98 ft) at the edge of the total area.

6.5.3 Turning missed approach

6.5.3.1 *General.* Turns may be prescribed at a designated TP, at a designated altitude/height, or “as soon as practicable”. The criteria used depend on the location of the turn relative to the normal termination of the precision segment and are as follows:

- a) *turn after normal termination of the precision segment.* If a turn is prescribed after the normal termination range of the precision segment, the criteria of Part I, Section 4, Chapter 6, 6.4.5, “Turn initiated at a designated altitude/height” apply with the following exceptions:
 - 1) OCA/H is replaced by (OCA/H – HL) as in 6.5.2.2, “Straight missed approach obstacle clearance”; and
 - 2) Because SOC is related to OCA/H, it is not possible to obtain obstacle clearance by the means used in non-precision approaches by independent adjustment of OCA/H or MAPt;
- b) *turn before normal termination of the precision segment.* If a turn is prescribed at a designated altitude/height less than 300 m above threshold or at a designated TP such that the earliest TP is within the normal termination range, the criteria specified in 6.5.3.2 and 6.5.3.3 below shall be applied;
- c) for missed approaches using RNAV or RNP, fly-by or flyover turns should be limited to 90 degrees. RF turns are not permitted as the first RNP leg of the missed approach since there would be no tangent RNP entry track specified. In this case, a TF leg with the first waypoint located on the extended LOC course is required, preceding the RF leg;
- d) the earliest location of the first RNAV or RNP fix is at a distance of ATT after the SOC (see Figure III-3-6-24). If the fix designates a fly-by turn, the additional distance $d_1 + 3V/3 600$ where V is the TAS must be added prior to the fix ($d_1 = r \tan A/2$); and
- e) for an RNAV or RNP missed approach, standard turn construction and turning MOC (50 m (164 ft) for turns of more than 15 degrees and 30 m (98 ft) for all other turns) shall apply after the earliest turning point. Secondary areas shall apply between the standard width of the RNAV or RNP primary area and the edge of the total area, except that obstacles located under the Y surface on the outer side of the turn need not be considered. See Figures III-3-6-21 and III-3-6-22.

Note.— Adjustments to designated TP location or to the designated turn altitude may involve redrawing the associated areas and recalculating the clearances. This can exclude some obstacles or introduce new ones. Thus, to obtain the minimum value of OCA/H it may be necessary to adjust the designated TP or turn altitude by trial and error. (See Part II, Section 1, Chapter 1, Appendix A.)

6.5.3.2 Turn at a designated altitude/height less than 300 m above threshold.

6.5.3.2.1 The general criteria apply (see Part I, Section 4, Chapter 6, 6.4.5, “Turn initiated at a designated altitude/height”) as amplified or modified by the contents of this section. Construction of the turn initiation area and the subsequent turn are illustrated in Figure III-3-6-18.

6.5.3.2.2 *Turn altitude/height.* The precision segment terminates at the TP. This allows the calculation of OCA/H_{ps} and (OCA/H_{ps} – HL). SOC is then determined, and turn altitude/height (TNA/H) is computed from the following relationship:

$$\text{TNA/H} = \text{OCA/H}_{\text{ps}} - \text{HL} + d_z \tan Z$$

where: d_z = is the horizontal distance from SOC to the TP
 OCA/H_{ps} = OCA/H calculated for the precision segment

If the TP is located at the SOC, the chart shall be annotated “turn as soon as practicable to... (heading or facility)” and include sufficient information to identify the position and height of the obstacles dictating the turn requirement.

6.5.3.2.3 Areas

6.5.3.2.3.1 *Turn initiation area.* (See Figure III-3-6-18). The turn initiation area is bounded by the 300 m Category I Y surface contour, and it terminates at the range of the TP.

Note.— *The earliest TP is considered to be at the beginning of the 300 m Category I Y surface contour (point D) unless a fix is specified to limit early turns (see 6.5.3.2.6, “Safeguarding of early turns”).*

6.5.3.2.3.2 *Turn area.* The turn area is constructed as specified in the general criteria (Part I, Section 4, Chapter 6, 6.4.3, “Turn parameters”).

6.5.3.2.4 Obstacle clearance

a) *Obstacle clearance in the turn initiation area.* Obstacle elevation/height in the turn initiation area shall be less than:

- 1) turn altitude/height –50 m (164 ft) (Cat H, 40 m (132 ft)) for turns more than 15°; and
- 2) turn altitude/height –30 m (98 ft) for turns 15° or less except that obstacles located under the Y surface on the outer side of the turn need not be considered when calculating turn altitude/height.

b) *Obstacle clearance in the turn area.* Obstacle elevation/height in the turn area and subsequently shall be less than:

$$\text{turn altitude/height} + d_o \tan Z - \text{MOC}$$

where d_o is measured from the obstacle to the nearest point on the turn initiation area boundary and MOC is:

- 1) 50 m (164 ft) (Cat H, 40 m (132 ft)) for turns more than 15°; and
- 2) 30 m (98 ft) for turns 15° or less,

reducing linearly to zero at the outer edge of the secondary areas, if any.

6.5.3.2.5 *Turn altitude/height adjustments.* If the criteria specified in 6.5.3.2.3 a) and/or b) above cannot be met, the turn altitude/height shall be adjusted. This can be done in two ways:

- a) *adjust turn altitude/height without changing OCA/H:* this means that the TP will be moved and the areas redrawn accordingly; and
- b) *raise turn altitude/height by increasing OCA/H:* this results in a higher turn altitude over the same TP. The turn areas remain unchanged.

6.5.3.2.6 *Safeguarding of early turns.* Where the published procedure does not specify a fix to limit turns for aircraft executing a missed approach from above the designated turn altitude/height, an additional check of obstacles shall be made (see Part I, Section 4, Chapter 6, 6.4.5.6, “Safeguarding of early turns”).

6.5.3.3 *Turn at a designated TP with earliest TP before normal termination of precision segment*

6.5.3.3.1 Where a turn is specified at a designated TP, and the earliest TP is before the normal termination range of the precision segment, the precision segment terminates at the earliest TP. This allows the calculation of OCA/H_{ps} and (OCA/H_{ps}–HL); SOC is then determined.

6.5.3.3.2 Where the procedure requires that a turn be executed at a designated TP, the following information must be published with the procedure:

- a) the TP, when it is designated by a fix; or
- b) the intersecting VOR radial NDB bearing DME distance where there is no track guidance (see Part I, Section 2, Chapter 2, 2.6.4, “Missed approach fixes”).

6.5.3.3.3 *Turn area.* The turn area is constructed as specified in Part I, Section 4, Chapter 6, 6.4.6.3, except that it is based on the width of the 300 m OAS Y surface contours at the earliest and latest TP (see Figure III-3-6-19).

6.5.3.3.4 *Obstacle clearance.* Obstacle elevation/height shall be less than:

$$(OCA/H_{ps} - HL) + d_o \tan Z - MOC$$

where: d_o = d_z + shortest distance from obstacle to line K-K,

d_z = horizontal distance from SOC to the earliest TP,

and MOC is:

50 m (164 ft) (Cat H, 40 m (132 ft)) for turns more than 15° and
30 m (98 ft) for turns 15° or less.

If the obstacle elevation/height exceeds this value, the OCA/H must be increased, or the TP moved to obtain the required clearance (see Part II, Section 1, Chapter 1, Appendix A).

6.6 SIMULTANEOUS ILS AND/OR MLS PRECISION APPROACHES TO PARALLEL OR NEAR-PARALLEL INSTRUMENT RUNWAYS

Note.— *Guidance material is contained in the Manual on Simultaneous Operations on Parallel or Near-Parallel Instrument Runways (Doc 9643).*

6.6.1 General

When it is intended to use precision approach procedures to parallel runways simultaneously, the following additional criteria shall be applied in the design of both procedures:

- a) the maximum intercept angle with the final approach course approach track is 30°. The point of intercepting the final approach track course shall be located at least 3.7 km (2.0 NM) prior to the point of intercepting the glide path;
- b) the minimum altitudes of the intermediate segments of the two procedures differ by at least 300 m (1 000 ft); and
- c) the nominal tracks of the two missed approach procedures diverge by at least 30°, the associated missed approach turns being specified as “as soon as practicable” which may involve the construction of (a) missed approach procedure(s).

A single GBAS is capable of serving both runways.

6.6.2 Obstacle clearance

The obstacle clearance criteria for precision approaches, as specified in the designated chapters, apply for each of the parallel precision procedures. In addition to these criteria a check of obstacles shall be made in the area on the side opposite the other parallel runway, in order to safeguard early turns required to avoid potential intruding aircraft from the adjacent runway. This check can be made using a set of separately defined parallel approach obstacle assessment surfaces (PAOAS). An example of a method to assess obstacles for these procedures is included in Part II, Section 1, Chapter 1, Appendix D.

6.7 GBAS CAT I WITH OFFSET AZIMUTH FINAL APPROACH TRACK ALIGNMENT

6.7.1 Use of GBAS Cat I with offset azimuth final approach track alignment

The final approach track shall intersect the runway extended centre line:

- a) at an angle not exceeding 5°; and
- b) at a point where the nominal glide path reaches a height called intercept height of at least 55 m (180 ft) above threshold elevation. The procedure shall be annotated: “final approach track offset... degrees” (tenth of degrees).

The general arrangement is shown in Figure III-3-6-20.

6.7.2 Obstacle clearance criteria

The provisions contained in 6.1 to 6.6 apply except that:

- a) all the obstacle clearance surfaces and calculations are based on a fictitious runway aligned with the final approach track. This fictitious runway has the same length and the same landing threshold elevation as the real one. The FTP is analogous to the LTP for aligned procedures. The GBAS course width at the FTP is the same as at the LTP. The DCP is located 15 m (50 ft) above the FTP; and
- b) the OCA/H for this procedure shall be at least: intercept altitude/height + 20 m (66 ft).

6.8 PROMULGATION

6.8.1 General

The general criteria in Part I, Section 4, Chapter 9 apply as amplified by criteria in Part III, Section 5, Chapter 1, 1.3.4 for chart notes. The instrument approach chart for a GBAS approach procedure shall be identified by the title GLS Rwy XX. If more than one GBAS approach is published for the same runway, the Duplicate Procedure Title convention shall be applied.

6.8.2 Promulgation of OCA/H values

Promulgation of OCA/H for GBAS Cat I approach procedures. The OCA or OCH values, as appropriate, shall be promulgated for those categories of aircraft for which the procedure is designed. The values shall be based on the following standard conditions:

- a) Cat I flown with pressure altimeter;
- b) standard aircraft dimensions (see 6.1.3); and
- c) 2.5 per cent missed approach climb gradient.

Additional values of OCA/H may be agreed between operators and the appropriate authority and promulgated, on the basis of evidence supporting the modifications defined in 6.4.8.7.

6.8.3 Minima box

A table of OCA/H values for each aircraft category may be promulgated for Cat I operations at the particular airfield.

6.8.4 Procedures involving non-standard glide path angles

Procedures involving glide paths greater than 3.5 degrees or any angle when the nominal rate of descent exceeds 5 m/s (1 000 ft/min), are non-standard and subject to restrictions (see 6.4.8.8.3.1). They are normally restricted to specifically approved operators and aircraft, and are promulgated with appropriate aircraft and crew restrictions annotated on the approach chart.

6.8.5 Additional gradient for the final missed approach segment

If obstacles identified in the final missed approach segment result in an increase in any of the OCA/H calculated for the precision segment, an additional steeper gradient may also be specified for the gradient of the missed approach surface (Z) for the purpose of lowering the OCA/H (see Part I, Section 4, Chapter 6, 6.2.2.2, “Climb gradient in the intermediate phase”).

6.8.6 Turns

6.8.6.1 *Turn at a designated altitude/height.* If the turn point is located at the SOC, the chart shall be annotated “turn as practicable to... (heading or facility)” and shall include sufficient information to identify the position and height of the obstacles dictating the turn requirement.

6.8.6.2 *Turn at a designated TP.* Where the procedure requires that a turn be executed at a designated TP, the following information must be published with the procedure:

- a) the TP, when it is designated by a fix; or
- b) the intersecting VOR radial, NDB bearing, or DME distance where there is no track guidance (see Part I, Section 2, Chapter 2, 2.6.4, “Missed approach fixes”).

6.8.7 Reference path identifier

Reference path identifier (RPI). The RPI, as defined in Part III, Section 2, Chapter 6, Appendix B, paragraph 3.5, shall be promulgated with the procedure information.

6.8.8 Channel number

GBAS channel number. The channel number for the procedure as defined in Annex 10, Volume I, Attachment D, paragraph 7.7, shall be promulgated with the procedure information.

6.8.9 GBAS reference point detail

GBAS reference point information. The following information about the GBAS reference point shall be promulgated with the procedure information: latitude/longitude of the GBAS reference point receivers, identifier, service volume radius, MSL elevation, and ellipsoid height.

Table III-3-6-1. Minimum distance between final approach and glide path interceptions

<i>Intercept angle with final approach (degrees)</i>	<i>Cat A/B/H</i>	<i>Cat C/D/D_L/E</i>
0 — 15	2.8 km (1.5 NM)	2.8 km (1.5 NM)
16 — 30	3.7 km (2.0 NM)	3.7 km (2.0 NM)
31 — 60	3.7 km (2.0 NM)	4.6 km (2.5 NM)
61 — 90 or within a racetrack or reversal procedure	3.7 km (2.0 NM)	5.6 km (3.0 NM)

Table III-3-6-2. Objects which may be ignored in OCA/H calculations

	<i>Maximum height above landing threshold</i>	<i>Minimum lateral distance from runway centre line</i>
Landing system antenna	17 m (55 ft)	120 m
Aircraft taxiing	22 m (72 ft)	150 m
A/C in holding bay or in taxi holding position at a range between threshold and 250 m (Cat I only)	15 m (50 ft)	75 m

Table III-3-6-3. Height loss/altimeter margin

Aircraft category (V_{at})	<i>Margin using radio altimeter</i>		<i>Margin using pressure altimeter</i>	
	Metres	Feet	Metres	Feet
A - 169 km/h (90 kt)	13	42	40	130
B - 223 km/h (120 kt)	18	59	43	142
C - 260 km/h (140 kt)	22	71	46	150
D/D _L - 306 km/h (165 kt)	26	85	49	161
H - 167 km/h (90 kt)	8	25	35	115

Note 1 — Cat H speed is the maximum final approach speed, not V_{at}

Note 2 — For Category E aircraft refer directly to the equations given in 6.4.8.8.3.4

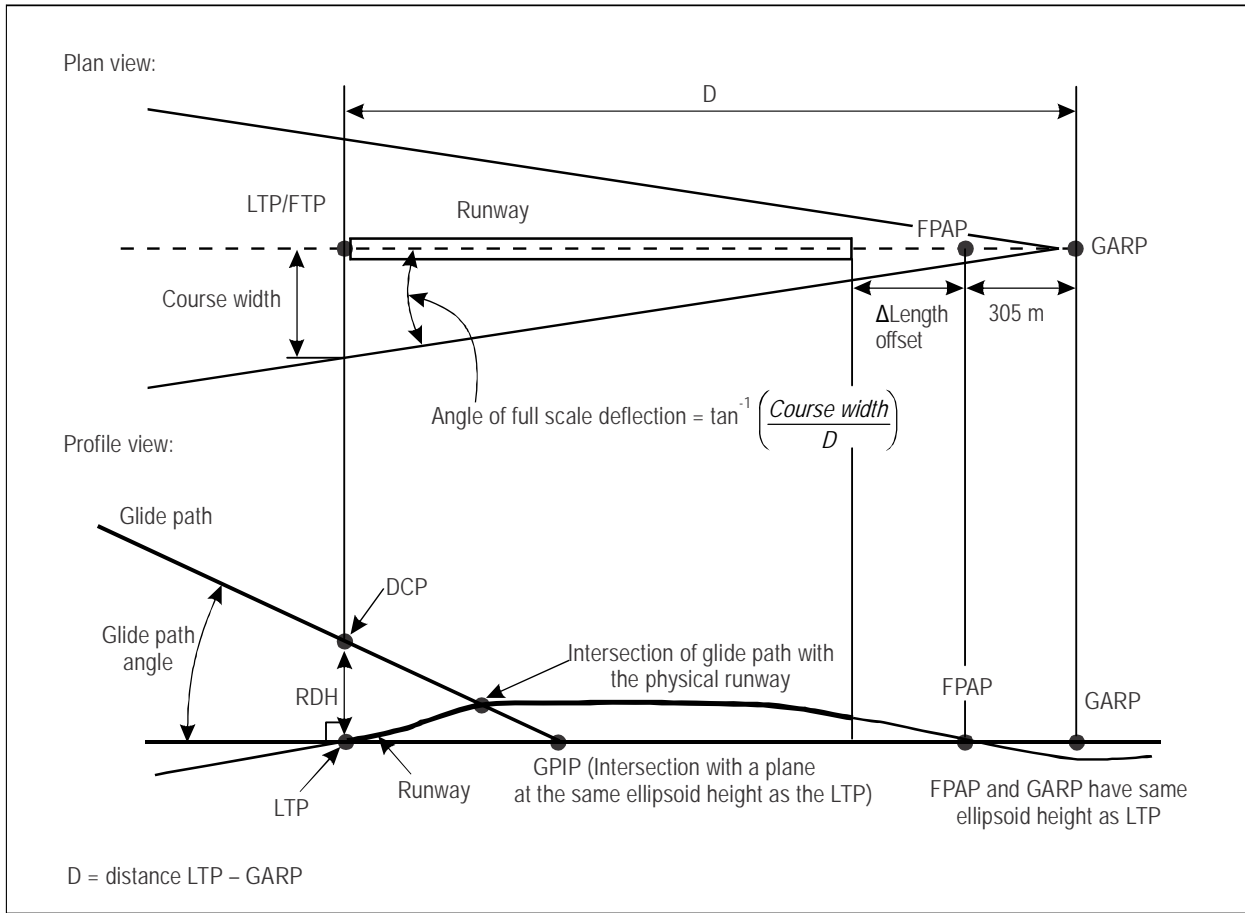

Figure III-3-6-1. Illustration of definitions

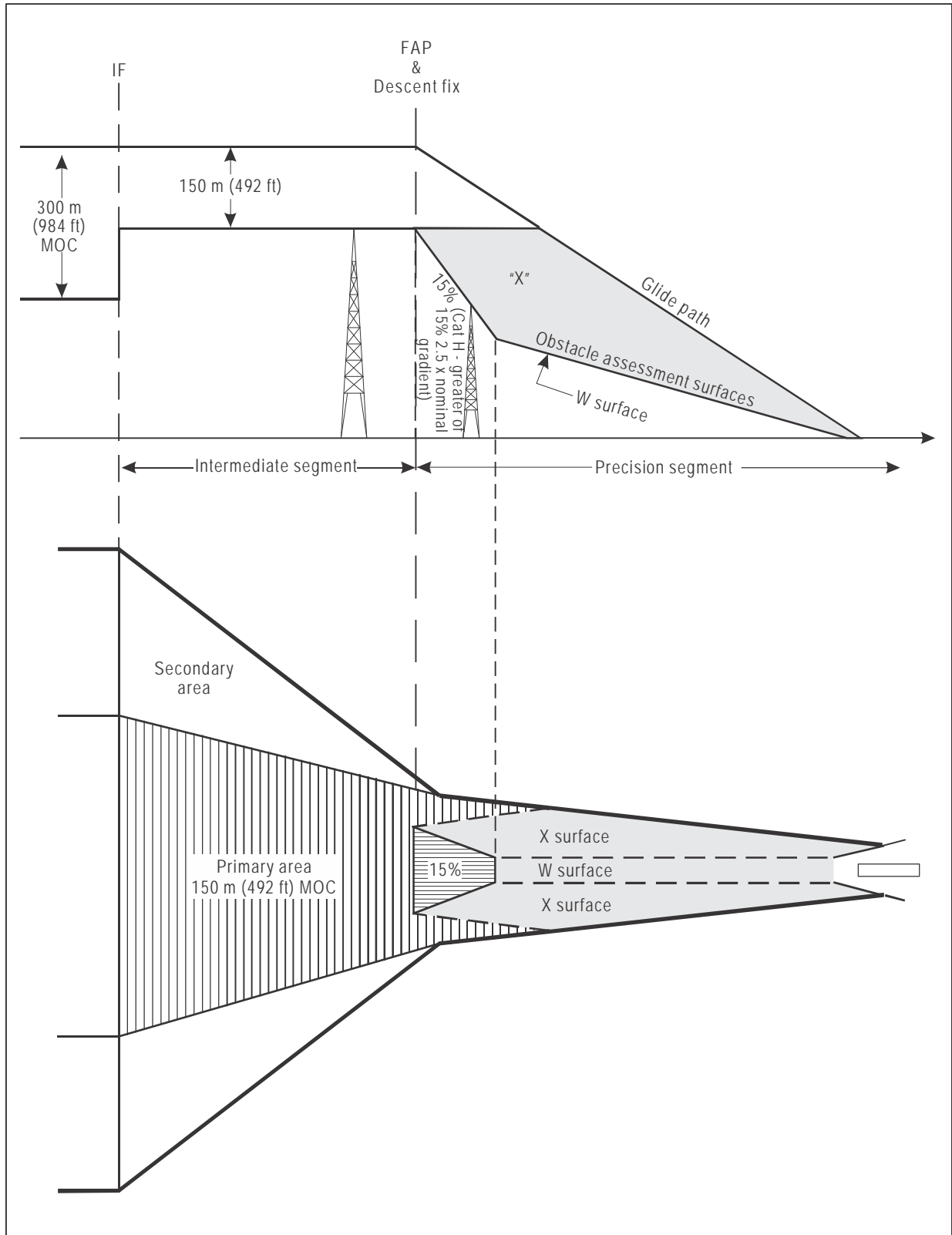

Figure III-3-6-2. Final approach point defined by descent fix

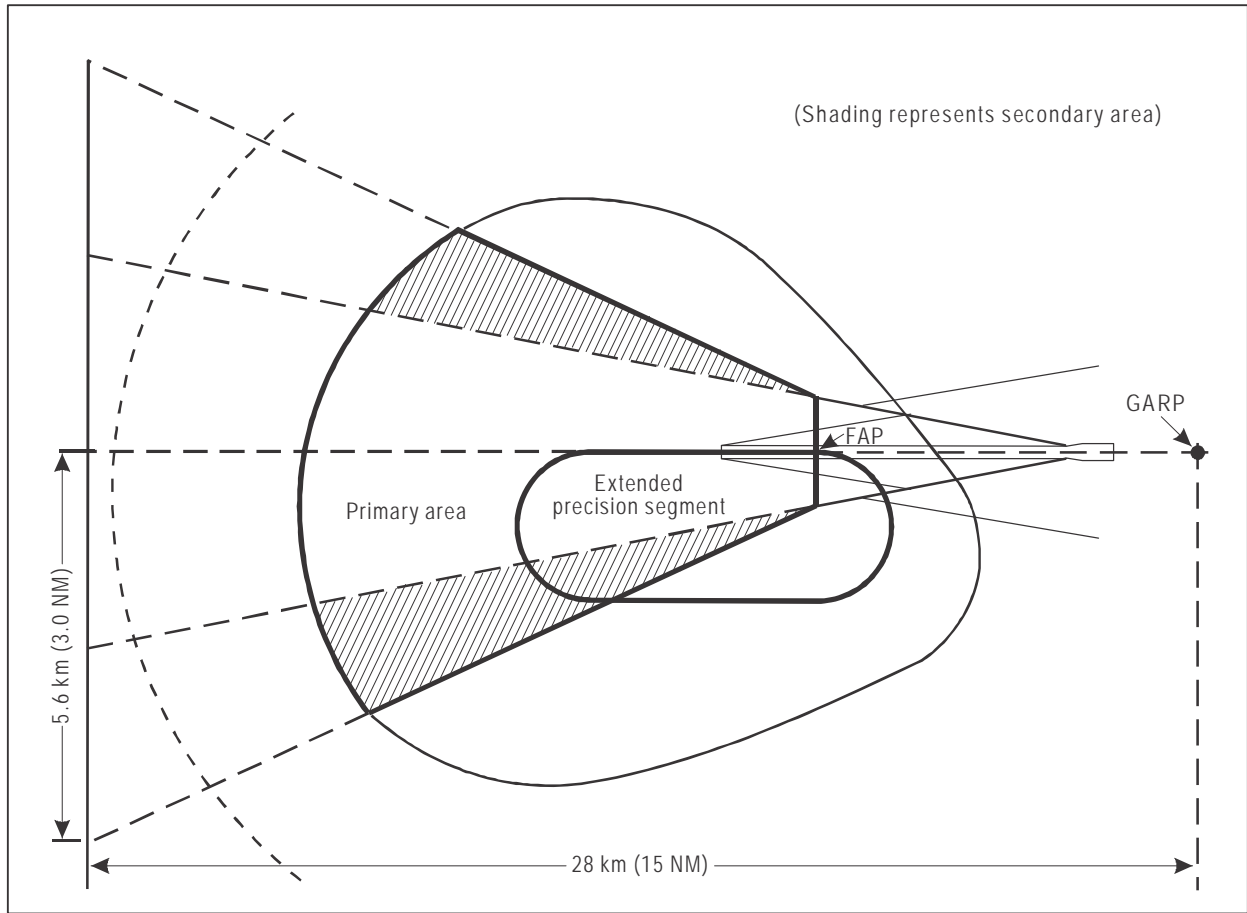

Figure III-3-6-3. Intermediate approach area. GBAS approach using reversal or racetrack procedure

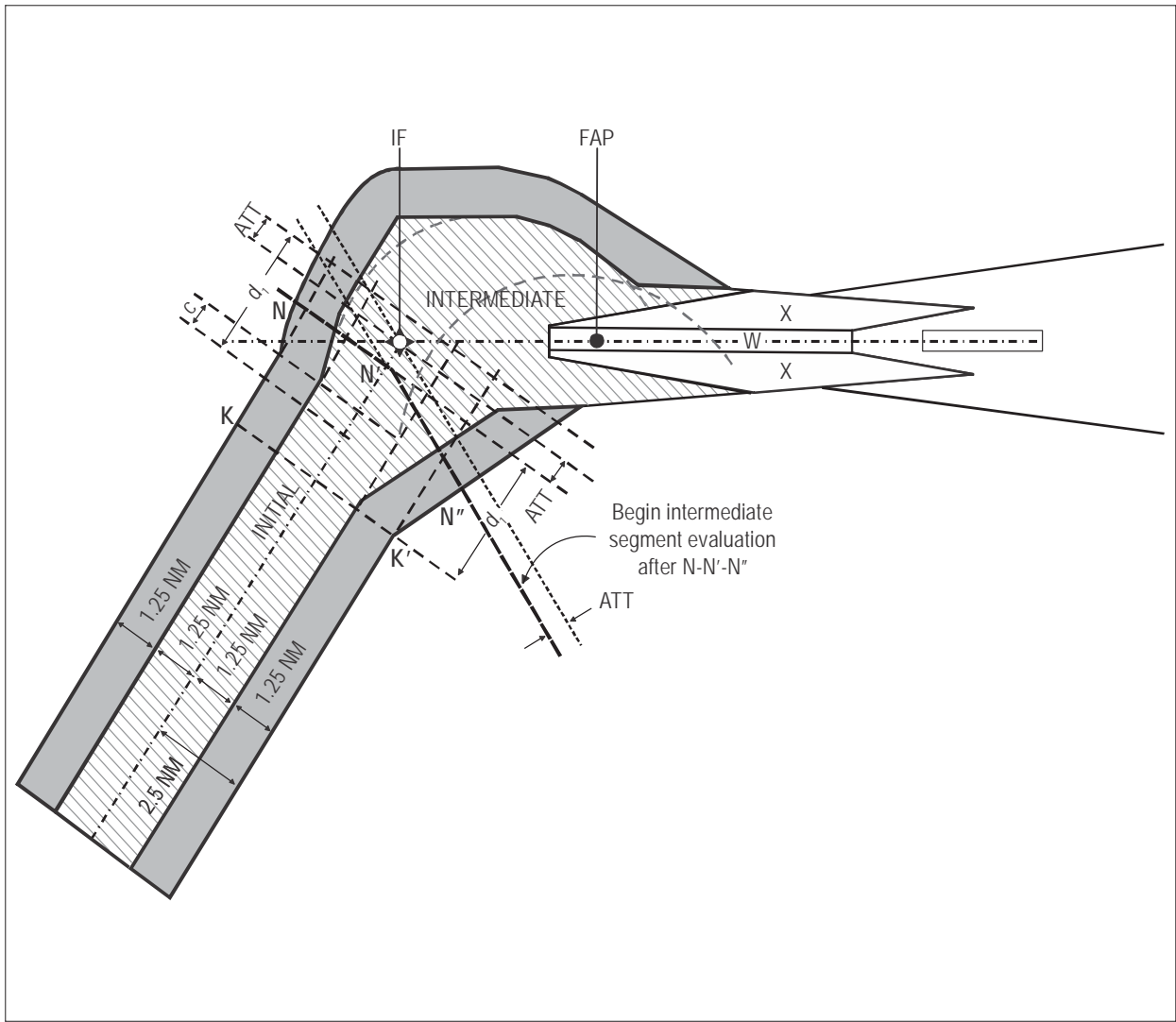

Figure III-3-6-4. Example: RNAV 1 or RNP 1 to GBAS transition, 60° intercept

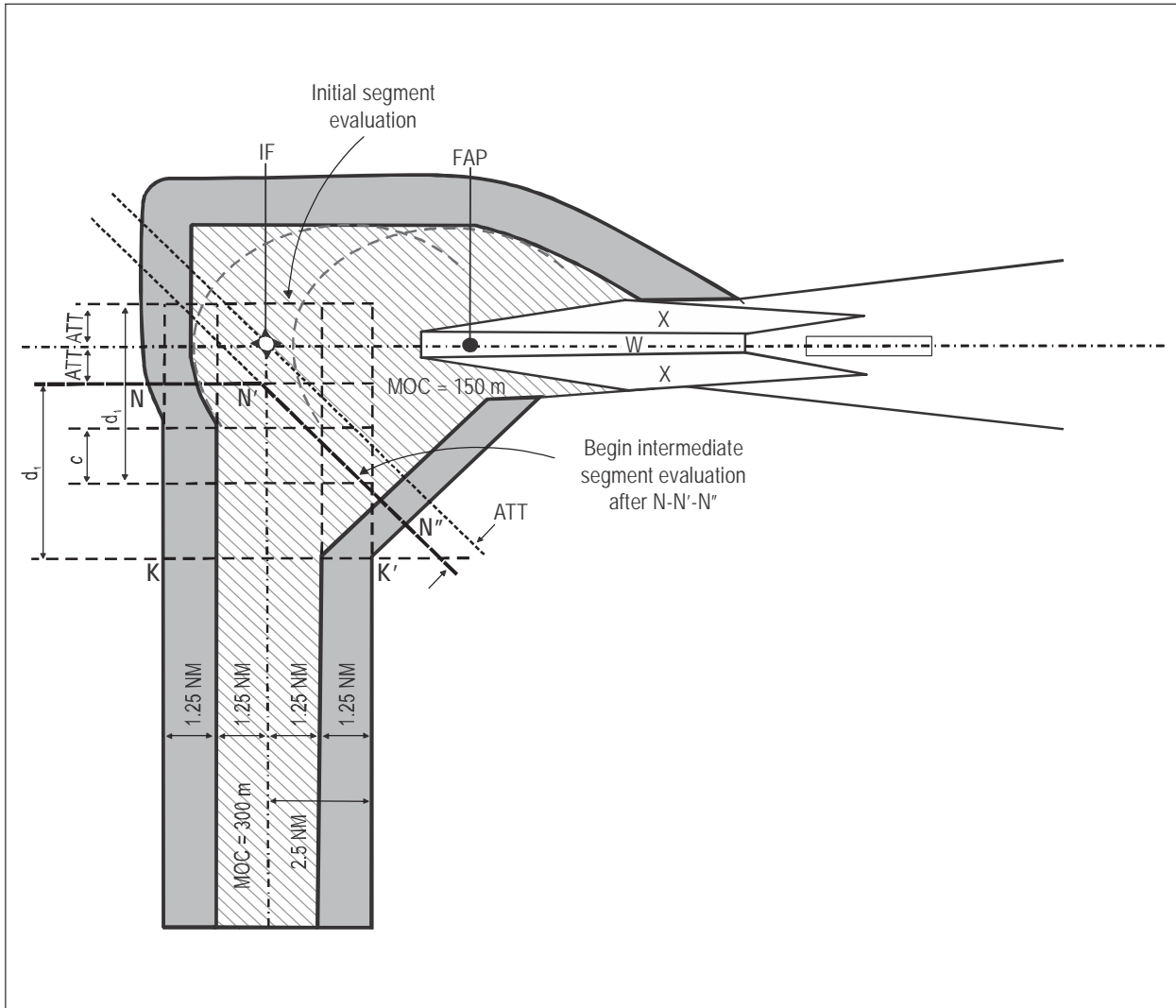

Figure III-3-6-5. Example: RNAV 1 or RNP 1 to GBAS transition, 90° intercept (max)

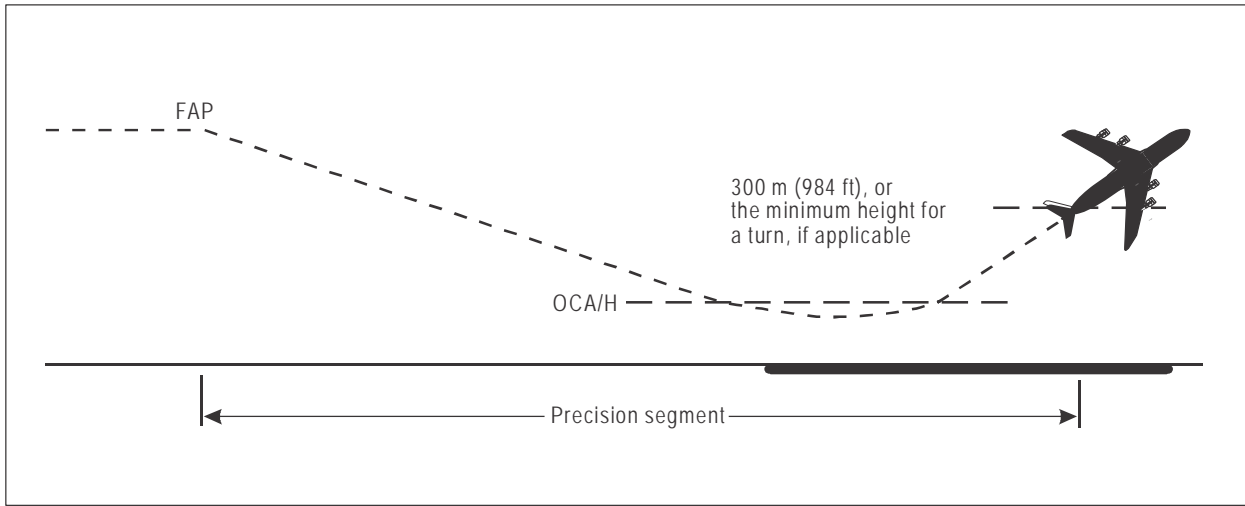

Figure III-3-6-6. Precision segment

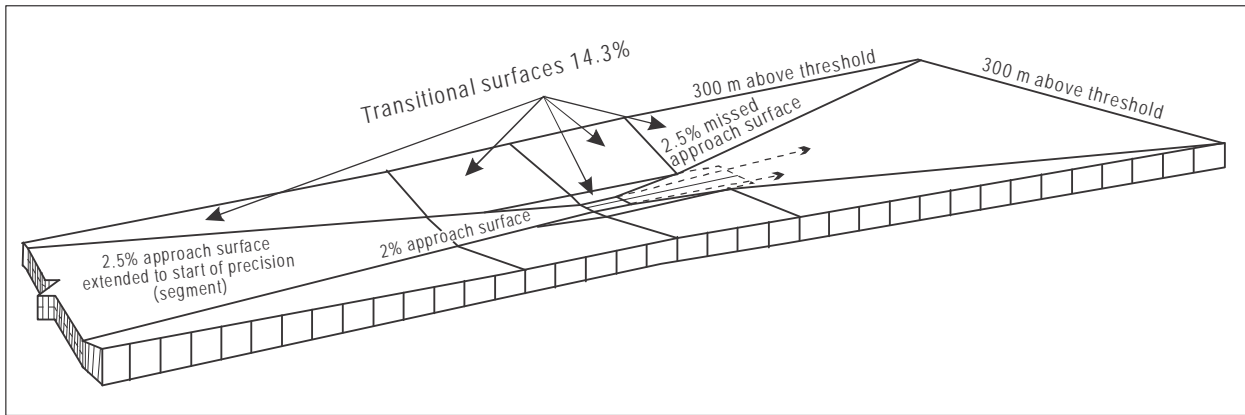

Figure III-3-6-7. Illustration of basic ILS surfaces as described in Part III, Section 3, Chapter 6, 6.4.7.2

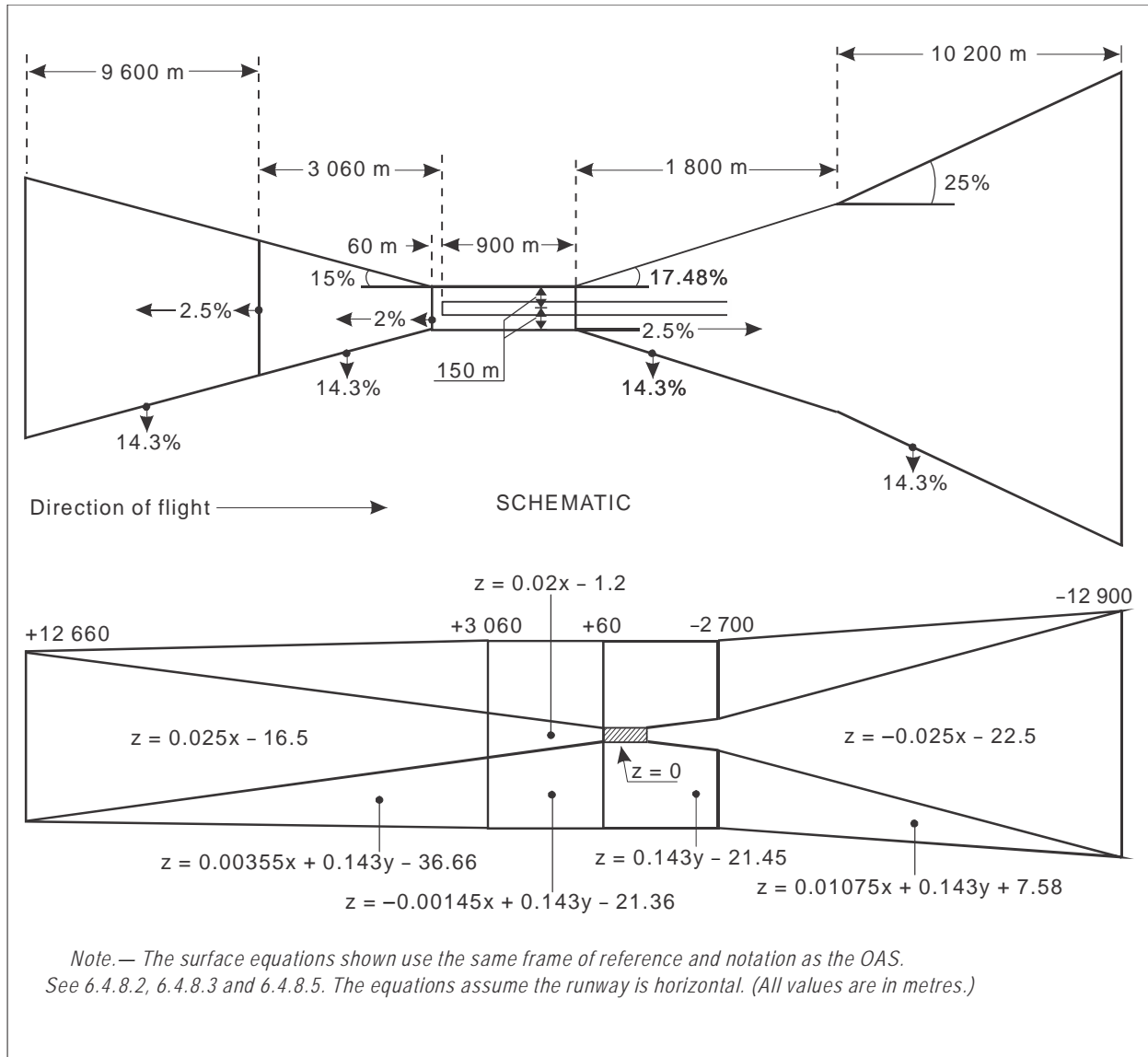

Figure III-3-6-8. Surface equations — basic ILS surfaces

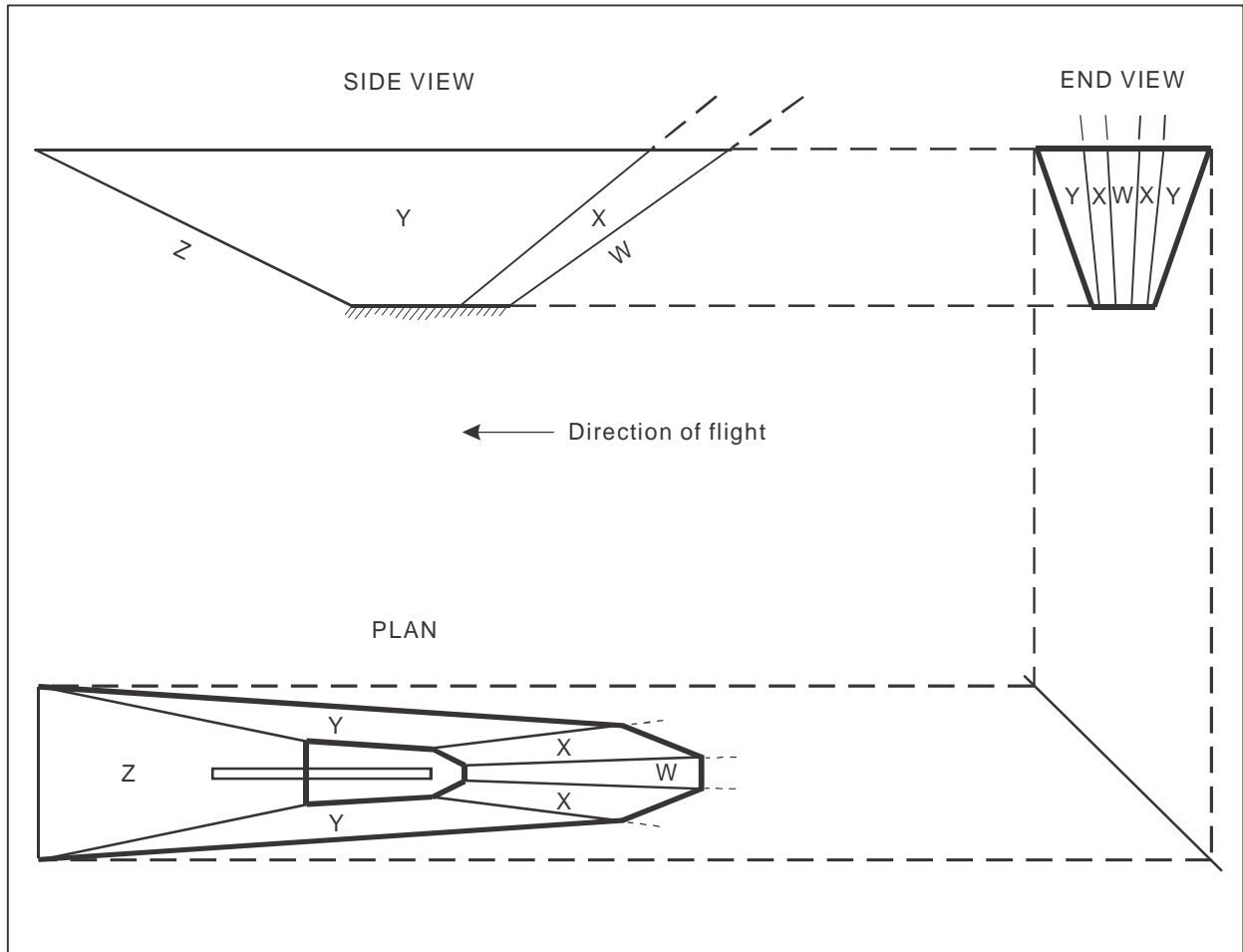

Figure III-3-6-9. Illustration of ILS obstacle assessment surfaces for GBAS operations

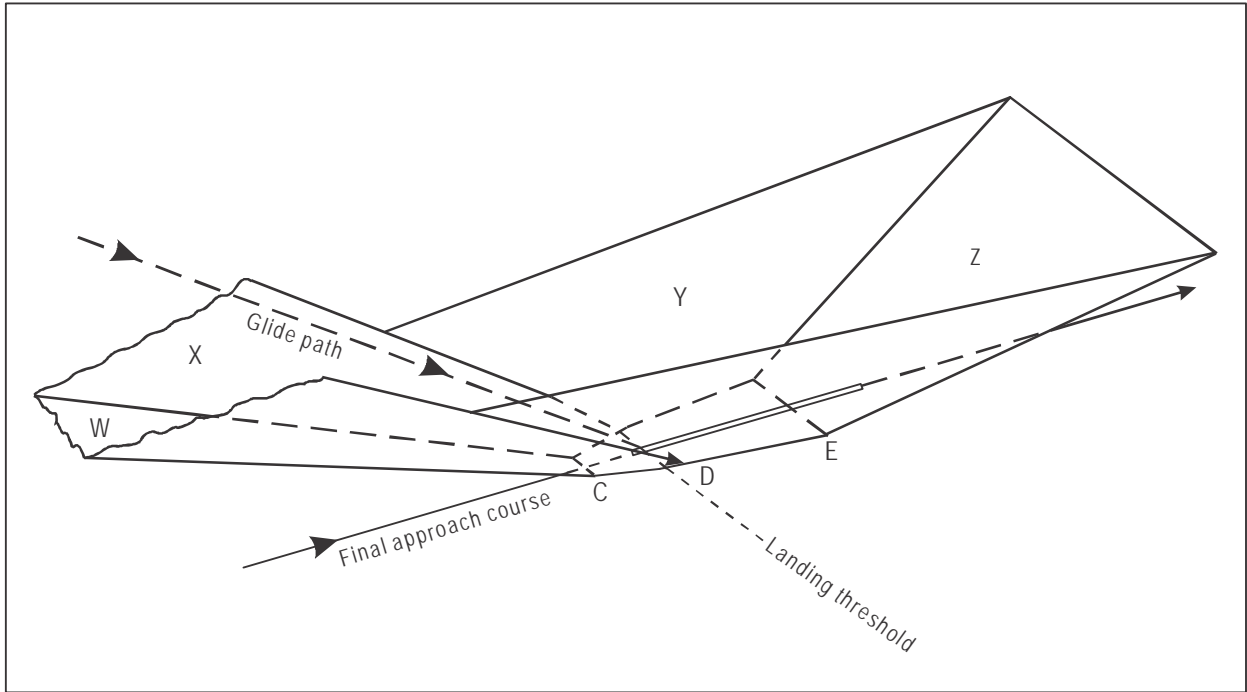

Figure III-3-6-10. Illustration of ILS obstacle assessment surfaces for GBAS operations — perspective view

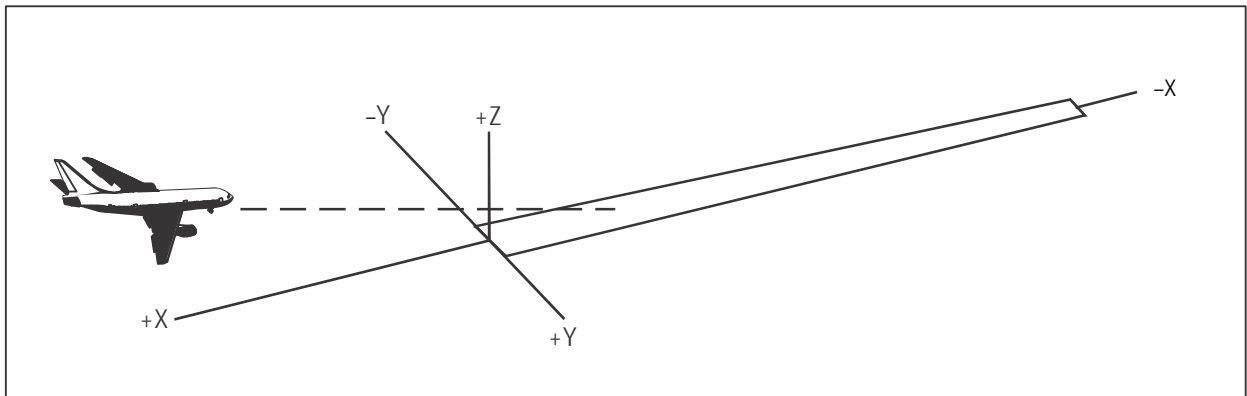

Figure III-3-6-11. System of coordinates

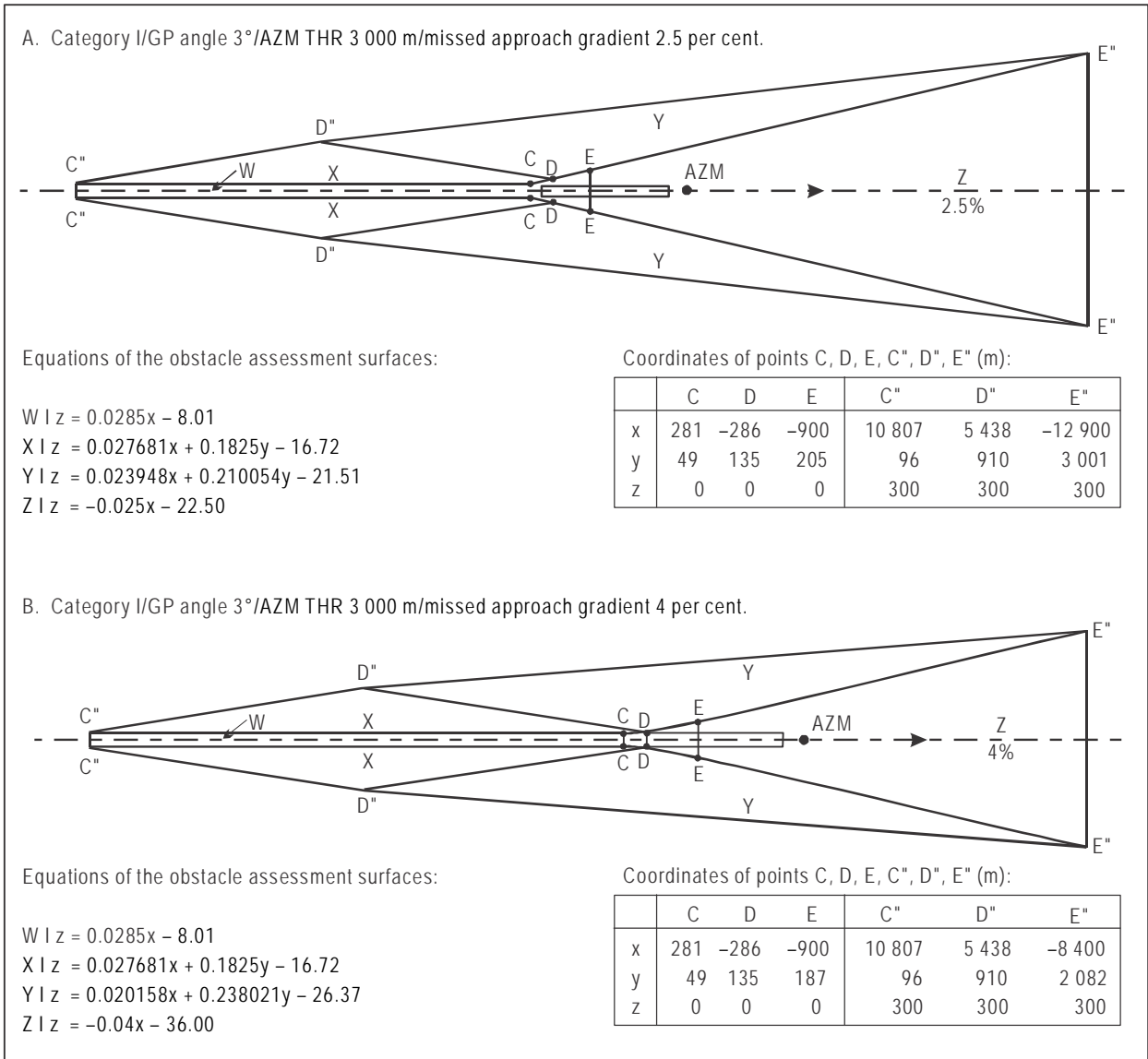

Figure III-3-6-12. Typical OAS contours for standard size aircraft

OAS

NAVIGATION AID DATA
 Approach Category
 Glide path (°) LOC THR Dist ⁽¹⁾ m
 RDH m Course width at THR m

AIRCRAFT DATA
 M/App CG (%) CAT STD Wing Semi Span m GP Wheel / Antenna height m

OAS constants

	A	B	C		A	B	C
W	<input type="text" value="0.028500"/>	<input type="text" value="0.000000"/>	<input type="text" value="-8.01"/>	Y	<input type="text" value="0.023948"/>	<input type="text" value="0.210054"/>	<input type="text" value="-21.51"/>
W*				Z	<input type="text" value="-0.025000"/>	<input type="text" value="0.000000"/>	<input type="text" value="-22.50"/>
X	<input type="text" value="0.027681"/>	<input type="text" value="0.182500"/>	<input type="text" value="-16.72"/>				

OAS Template coordinates -m (metres)

THR Elevation		300 m Height			
	X	Y	X	Y	
C	<input type="text" value="281"/>	<input type="text" value="49"/>	C"	<input type="text" value="10807"/>	<input type="text" value="96"/>
D	<input type="text" value="-286"/>	<input type="text" value="135"/>	C'''		
E	<input type="text" value="-900"/>	<input type="text" value="205"/>	D"	<input type="text" value="5438"/>	<input type="text" value="910"/>
			E"	<input type="text" value="-12900"/>	<input type="text" value="3001"/>

OAS height calculator
 X m Y m Z m

(1) For MLS read: "Azimuth antenna to THR distance"; for GBAS read: "GARP-LTP distance".

Figure III-3-6-13. OAS output data generated by the PANS-OPS OAS software

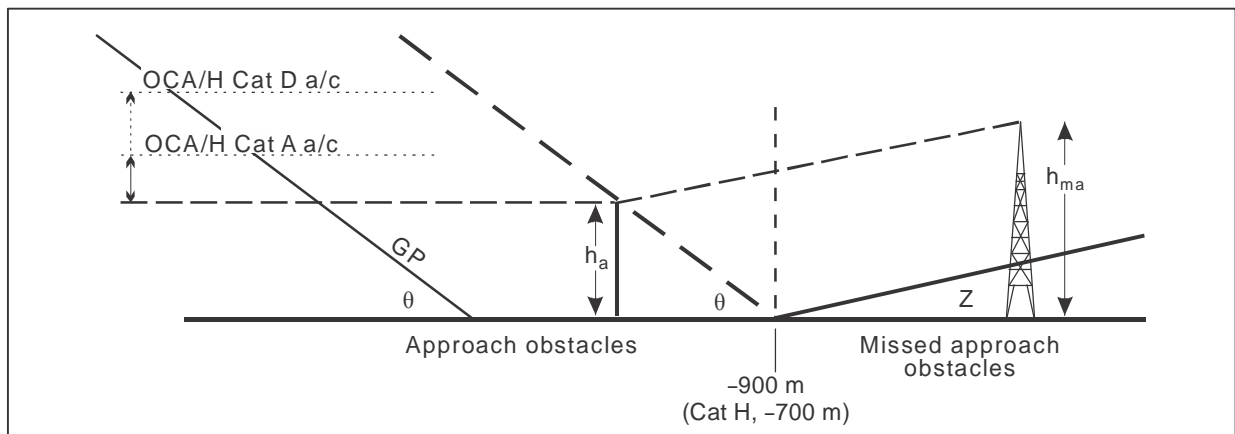

Figure III-3-6-14. Missed approach obstacle after range -900 m

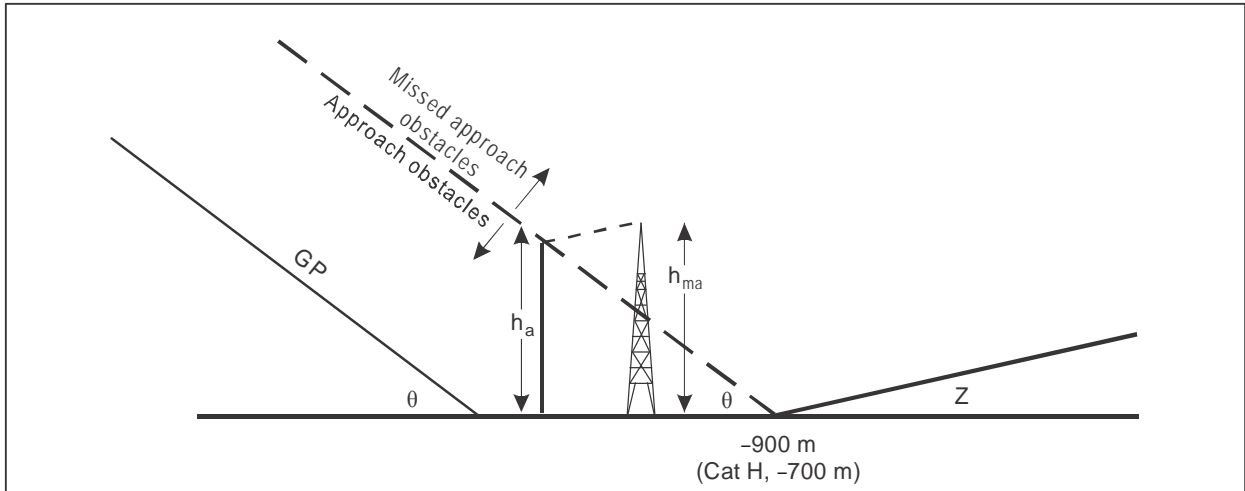

Figure III-3-6-15. Missed approach obstacle before range -900 m

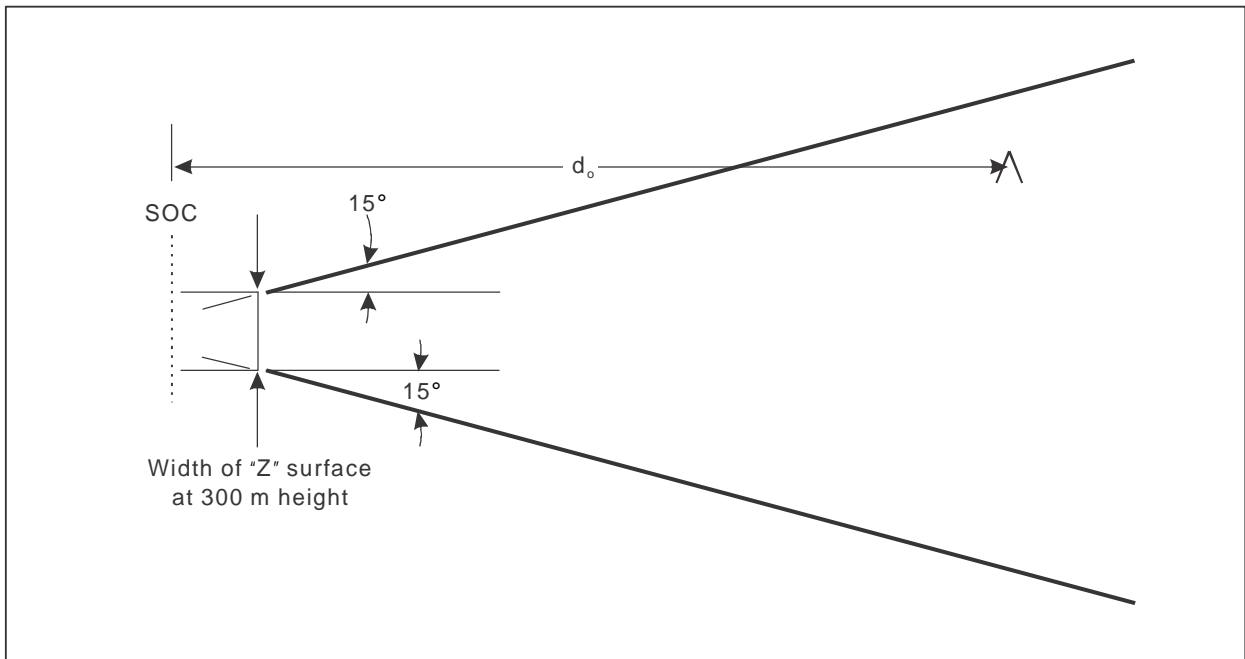

Figure III-3-6-16. Final segment of straight missed approach

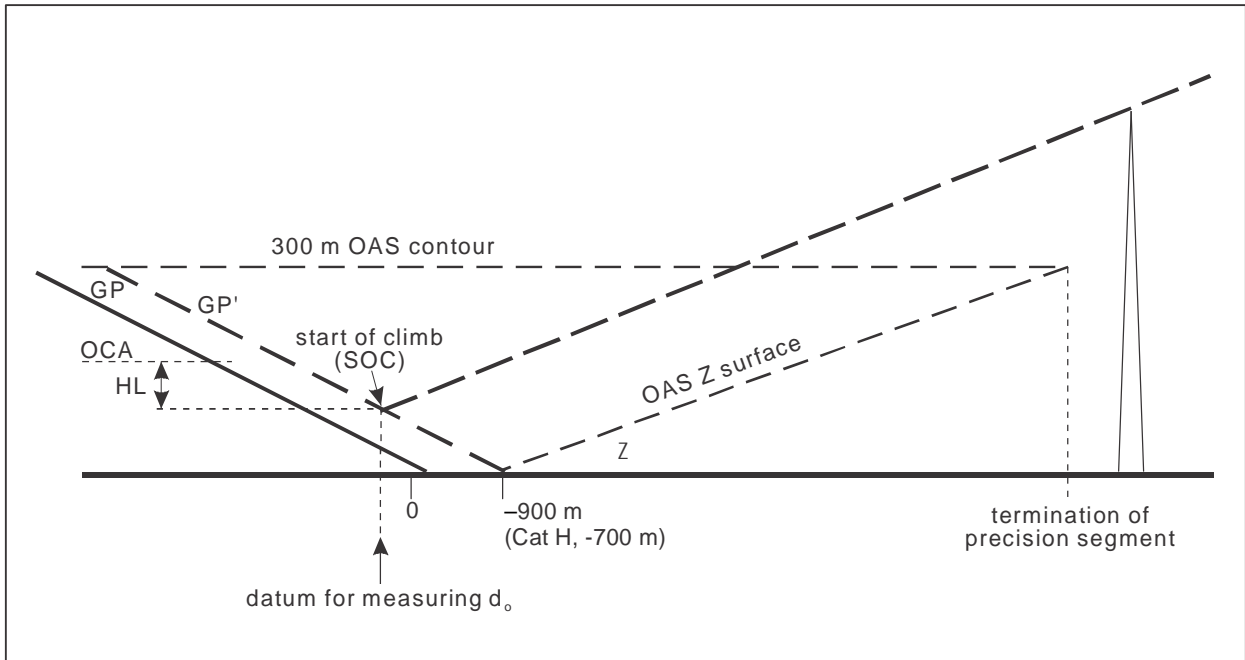

Figure III-3-6-17. Straight missed approach obstacle clearance

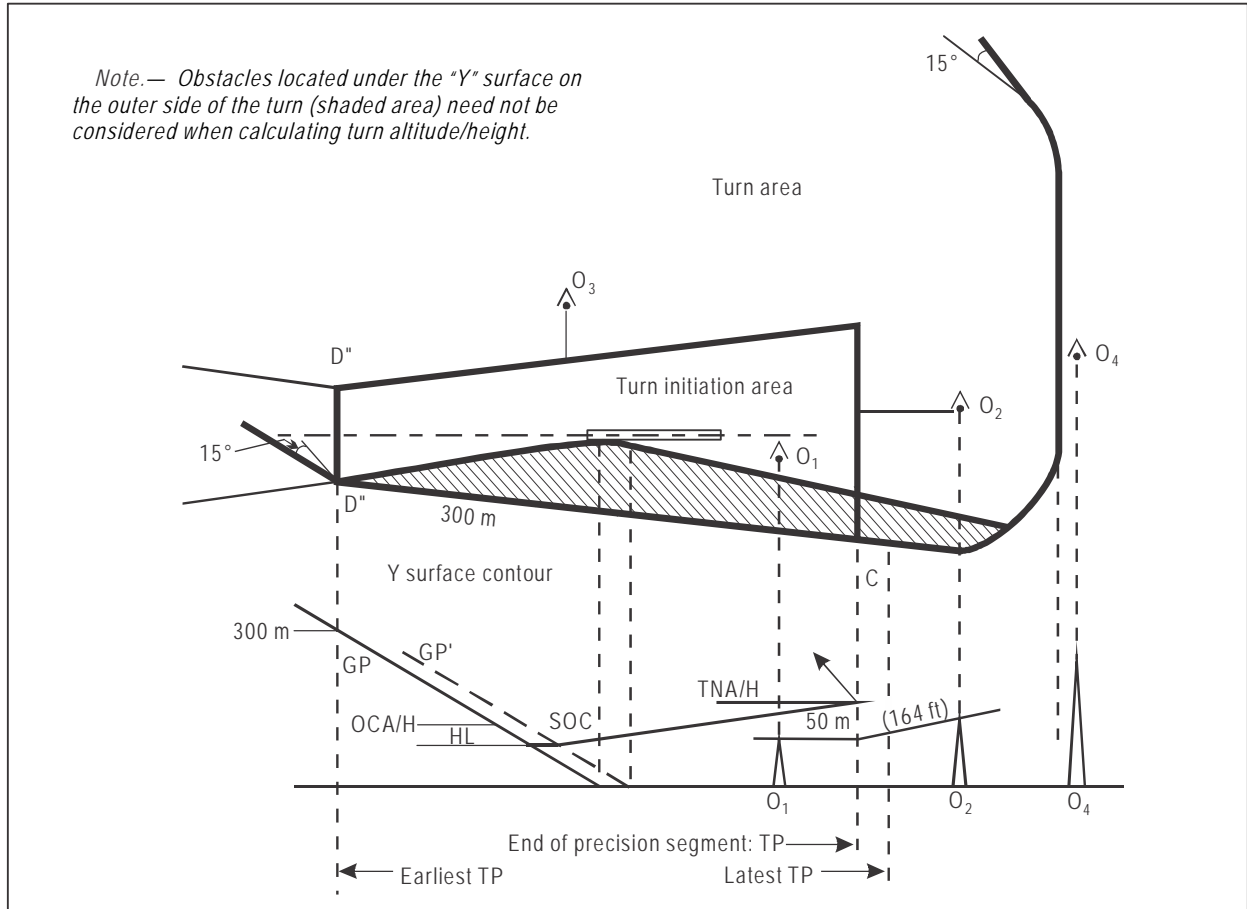

Figure III-3-6-18. Turn at a designated altitude

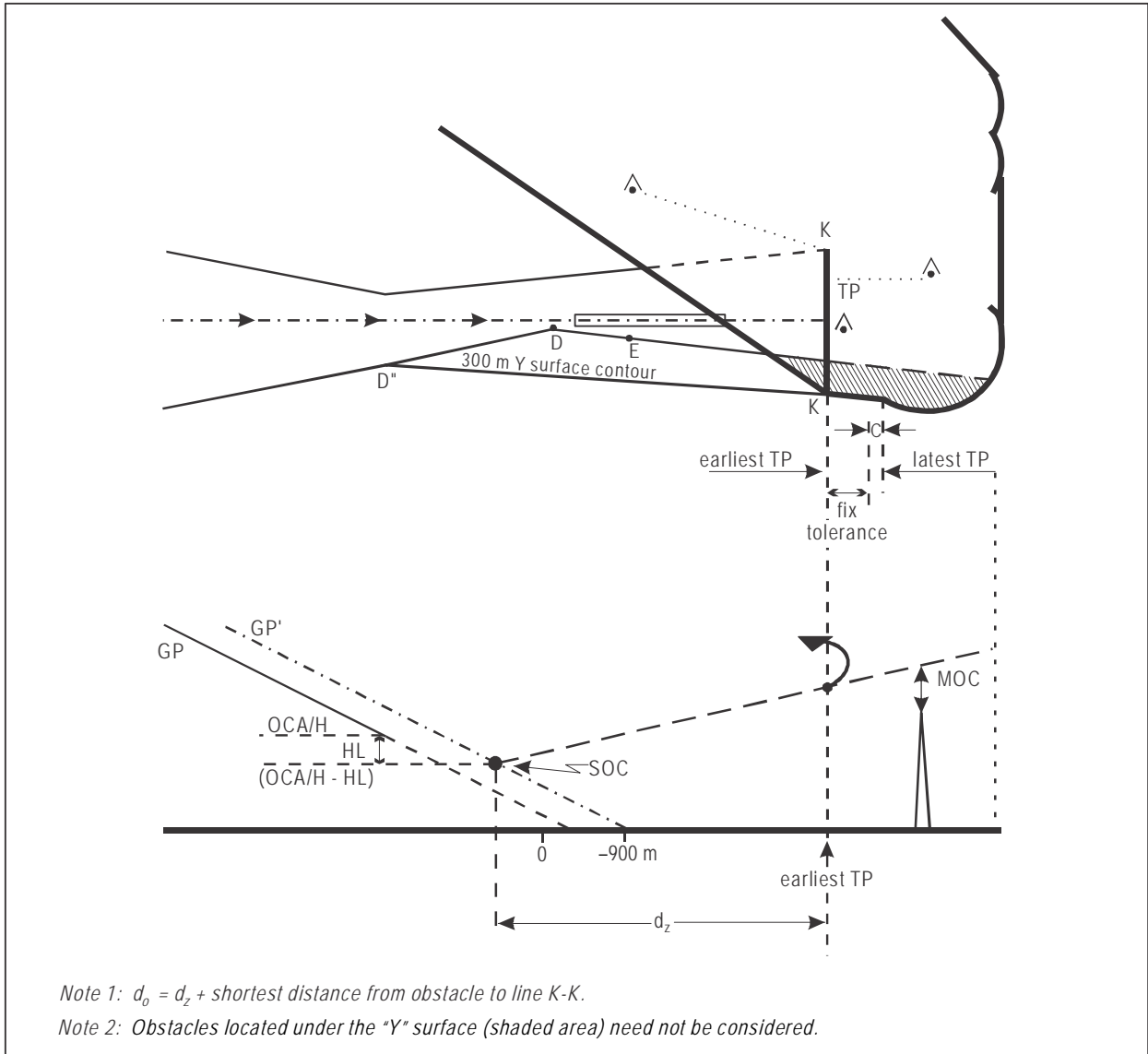

Figure III-3-6-19. Turn at designated TP (with TP fix)

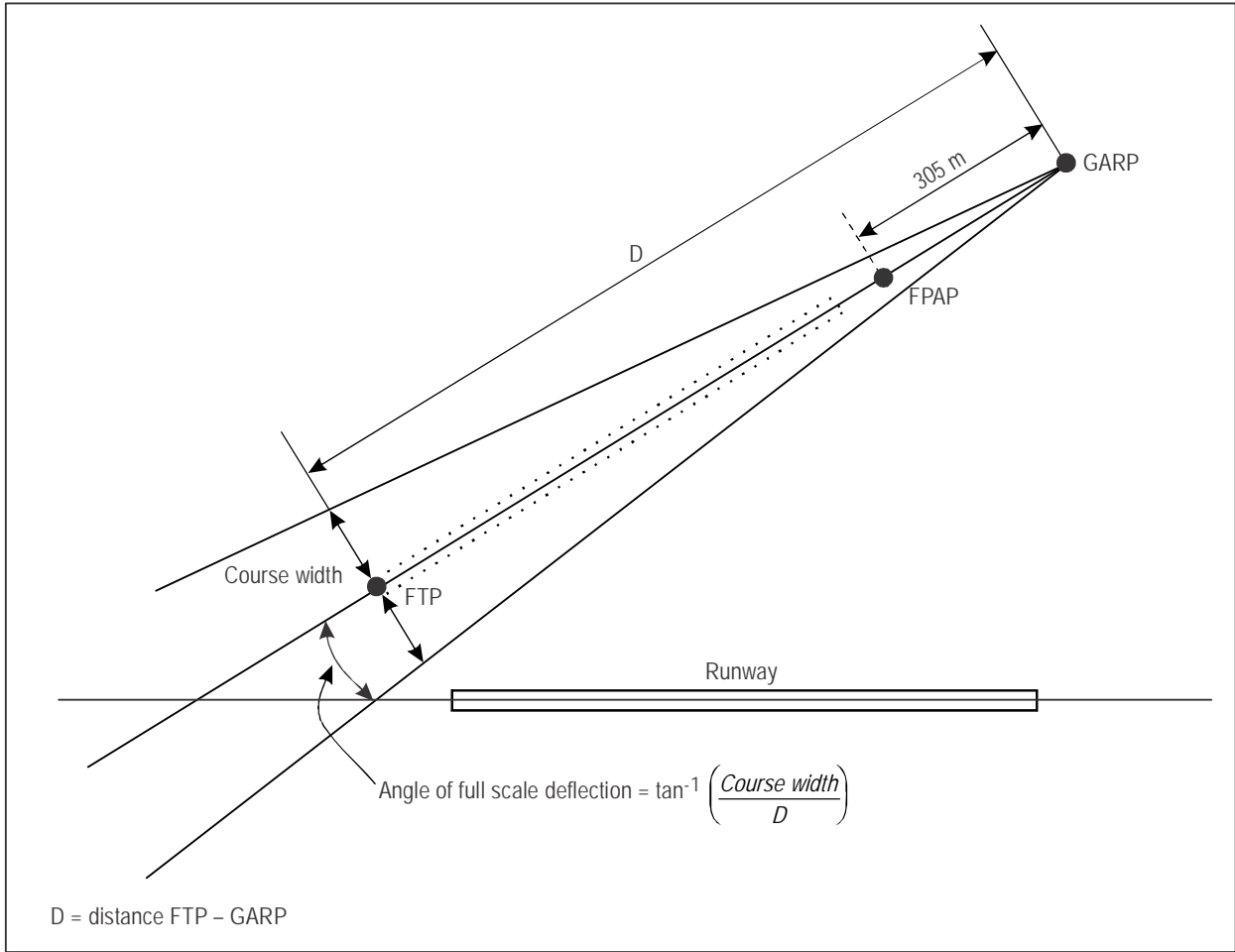

Figure III-3-6-20. GBAS Cat I with offset azimuth final approach course alignment

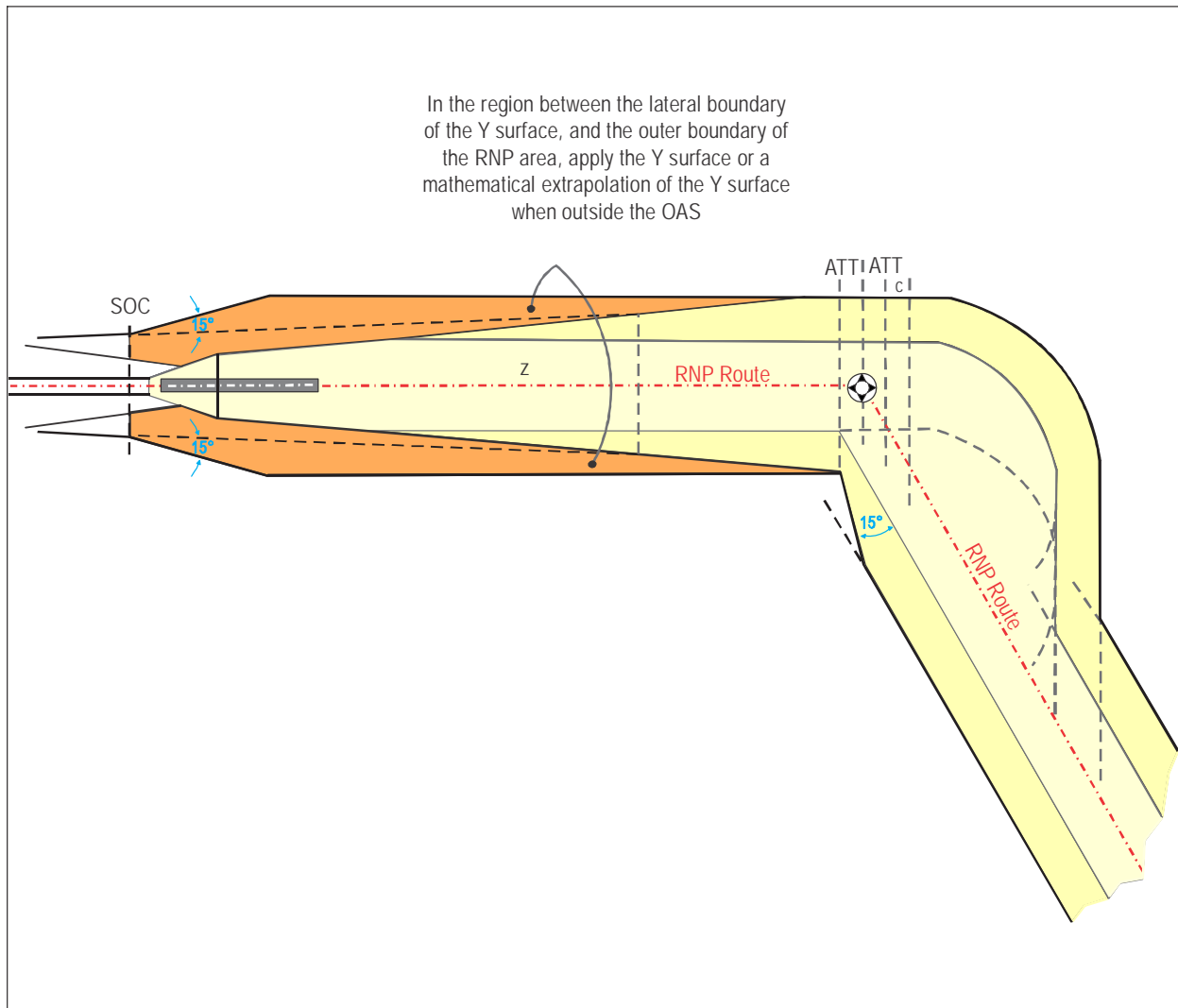

Figure III-3-6-21. Example: Transition to RNP 1, flyover turn after the precision segment

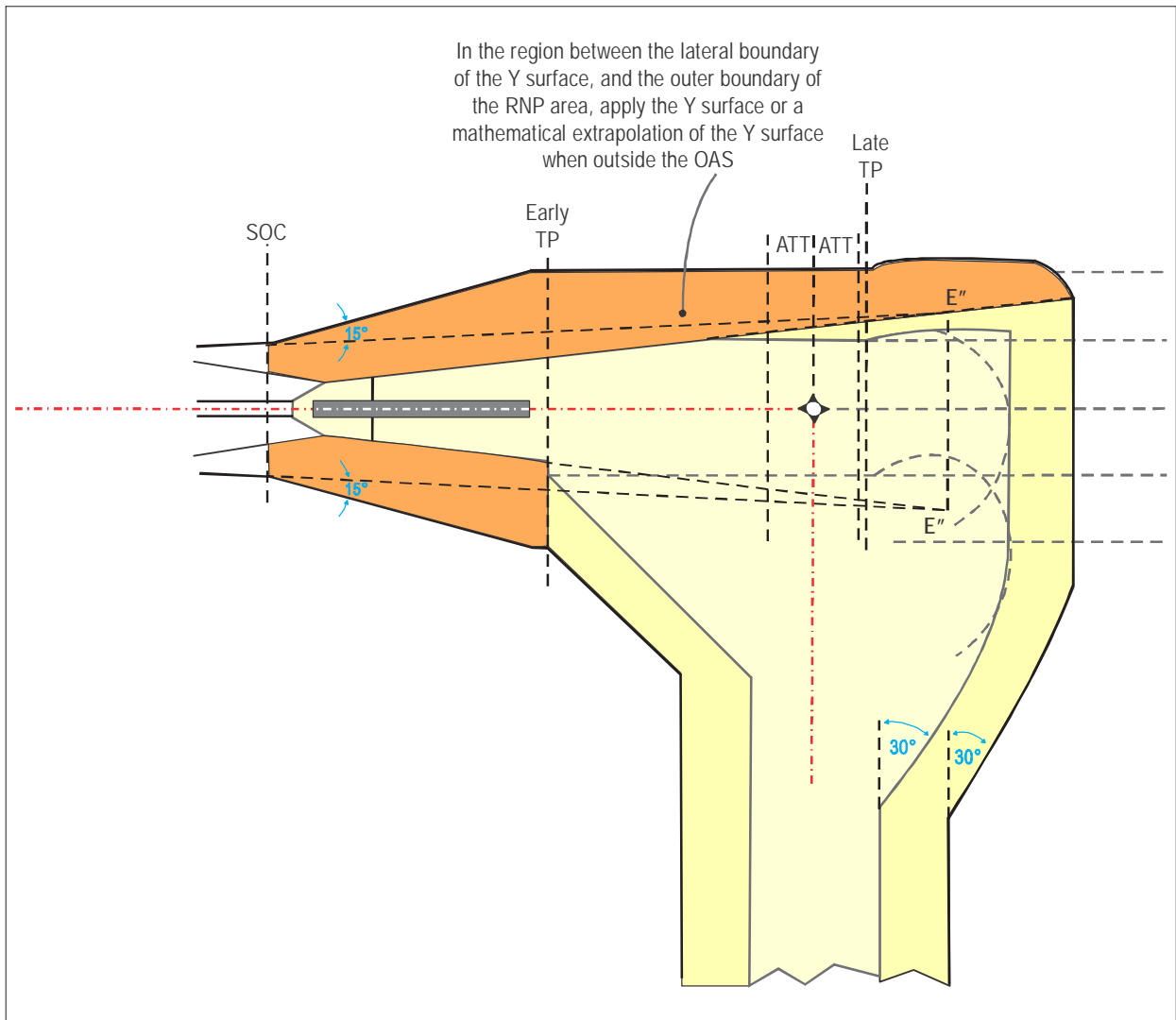

Figure III-3-6-22. Example: Transition to RNAV 1 or RNP 1, fly-by turn before the end of the precision segment

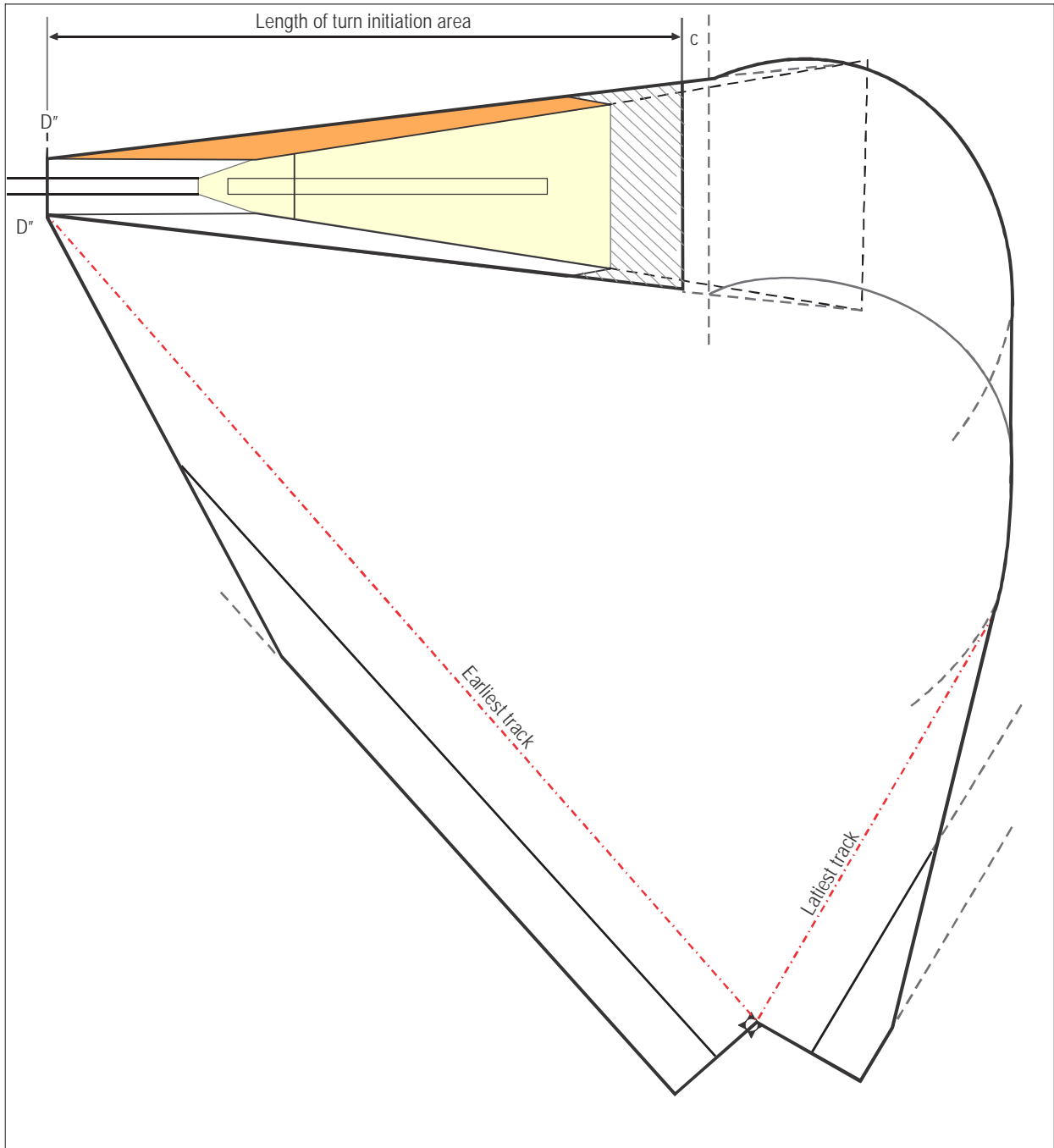

Figure III-3-6-23. Example: Turn at an altitude direct to an RNAV 1 or RNP 1 fix

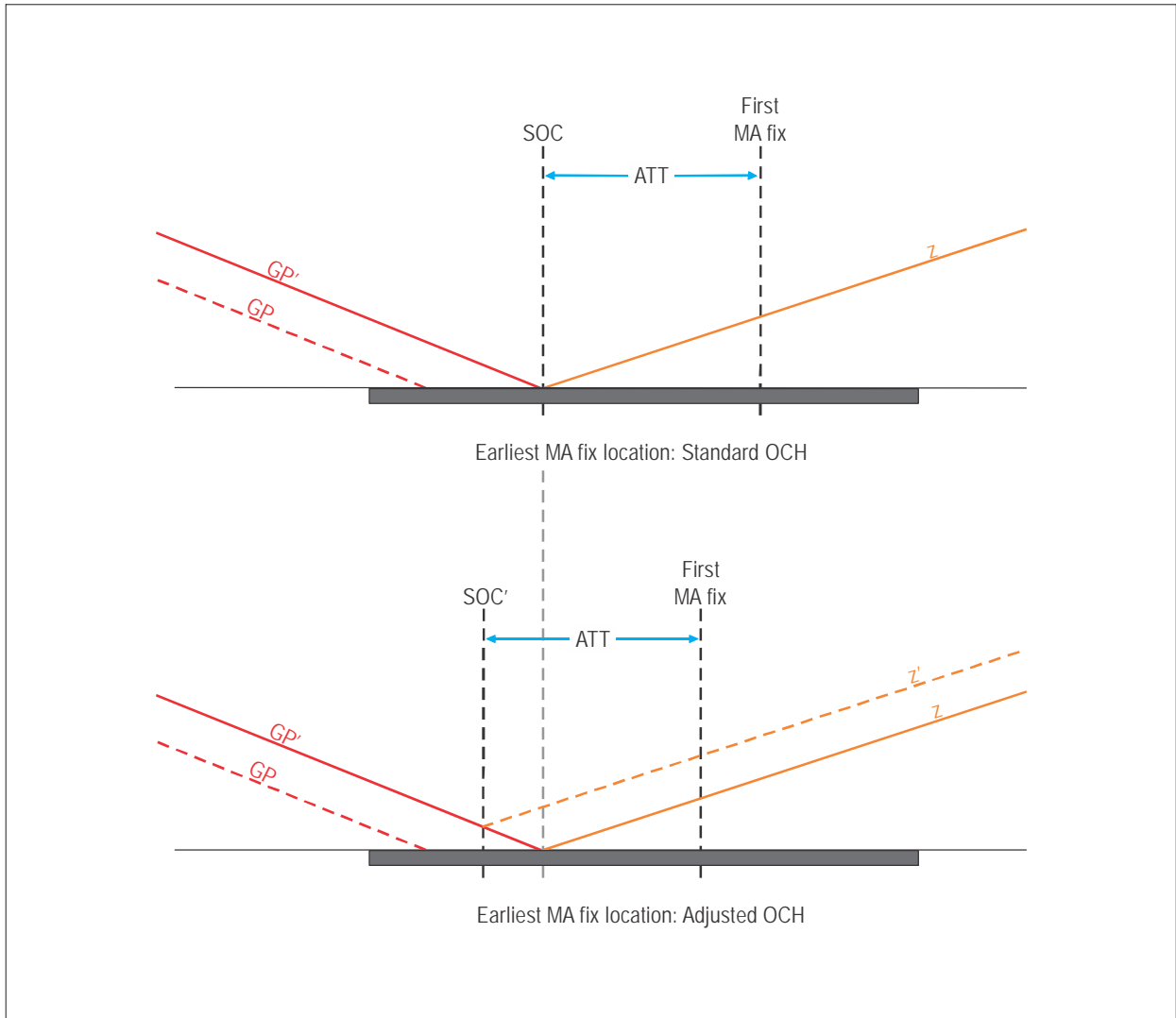

Figure III-3-6-24. Earliest fix location for RNAV or RNP missed approach

Chapter 7

HOLDING PROCEDURES

7.1 GENERAL

7.1.1 This chapter contains the criteria for RNAV holding procedures.

7.1.2 Holding procedures can be designed both for operations with navigation specifications that require and do not require an aircraft equipment holding functionality.

7.1.2.1 *Navigation specifications requiring RNAV systems with holding functionality.* Aircraft equipped with RNAV systems have the flexibility to hold on tracks which are defined by the RNAV equipment and to use procedures which are less rigid than those used in conventional holdings. The benefits of using this technique include the optimum utilization of airspace with regard to the siting and alignment of holding areas as well as, under certain circumstances, a reduction of holding area airspace. The only navigation specification requiring an area navigation system with a holding functionality is advanced RNP.

7.1.2.2 *Navigation specifications not requiring RNAV systems with holding functionality.* For RNAV systems without any holding functionality it is possible to define an RNAV holding procedure, to be flown manually, based on a waypoint. A conventional holding template shall be used to construct the obstacle clearance area for this type of holding.

7.1.3 Flight management systems are normally controlled through a navigation database.

7.1.4 *Location and number of holding patterns.* To avoid congestion only one holding pattern should be established for each procedure. The normal location would be at one of the IAFs. The holding waypoint is treated as a flyover waypoint.

7.2 TYPES OF RNAV HOLDING PROCEDURES

7.2.1 The following two types of RNAV holding procedures may be established:

a) waypoint RNAV holding:

- 1) for operations requiring RNAV systems with holding functionality; and
- 2) for operations not requiring RNAV systems with holding functionality; and

b) RNAV area holding. This type of holding may be applied for both types of operations as specified in 7.1.2.

The general criteria contained in Part I, Section 4, Chapter 3, Appendix C for conventional holding using an outbound leg defined by distance apply as modified by the criteria listed under each holding type.

7.2.2 Waypoint RNAV holding

(See Figure III-3-7-1 A.)

7.2.2.1 Operations requiring RNAV systems with holding functionality

- a) It is assumed that the RNAV system is able to compensate for the effect of a wind coming from the outside of the outbound turn by a reduction of the bank angle.
- b) The length of the outbound leg of the holding pattern is at least equal to one diameter of turn.
- c) It is assumed that the RNAV system is able to correct the drift on straight segments.
- d) No heading tolerance is taken into account on the straight segments.

7.2.2.2 Operations not requiring RNAV systems with holding functionality (i.e. class A GNSS receivers)

- a) This type of holding will be flown manually, and RNAV track guidance is provided only on the inbound track.
- b) No wind compensation effects or drift correction by the RNAV system are considered.
- c) The end of the outbound leg of the holding is defined by timing or by a distance from the holding waypoint (WD) provided by the RNAV system.

7.2.3 *Area holding.* This type of holding provides a circular area, centred on a designated waypoint, large enough to contain a standard racetrack holding pattern in any orientation. (See Figure III-3-7-1 B.)

7.3 ENTRY PROCEDURES

7.3.1 Waypoint RNAV holding

Entry procedures to a waypoint RNAV holding shall be the same as those used for conventional holding.

7.3.2 Area holding

Any entry procedure which is contained within the given area is permissible.

7.4 FIX TOLERANCE

7.4.1 The fix tolerance is the greater of the fix tolerances of the individual sensors allowed for in the application of the navigation specification operation. DME/DME and GNSS fix tolerance are described in Section 1, Chapter 3, 3.6 and Chapter 2, 2.2 respectively.

Note.— Some regional operations allow the use of VOR/DME.

7.4.2 For VOR/DME fix tolerance the following two paragraphs apply.

7.4.2.1 *Fix tolerance — waypoint holding.* The waypoint tolerances for the construction of waypoint fix tolerance areas (VT, DT, AVT, ADT) are calculated as shown in Section 1, Chapter 4, 4.6, “XTT, ATT and area semi-width”.

7.4.2.2 *Fix tolerance — area holding.* In order to achieve a circular holding area it is necessary to construct a circular waypoint fix tolerance area centred on the holding waypoint. The radius (R^t) of this tolerance area is given by:

$$R^t = \max(\text{DTT}, D \sin \alpha)$$

where: α = VOR system use accuracy
 DTT = DME system use accuracy
 D = distance from holding waypoint to VOR/DME.

7.5 HOLDING AREA CONSTRUCTION

7.5.1 Waypoint RNAV holding area

The holding area is constructed by applying the techniques in Part II, Section 4, Chapter 1, 1.3, “Construction of holding areas” to the waypoint tolerance area.

7.5.2 Protection area construction for waypoint RNAV holding

7.5.2.1 The general criteria described in 3.3, “Protection area of racetrack and holding procedures” of Part I, Section 4, Chapter 3, Appendix C, “Construction of obstacle clearance areas for reversal and holding procedures” apply as modified by the criteria in this paragraph. The criteria are broken down into three steps (see Appendix A, paragraph 1).

7.5.2.2 This additive tolerance method, the template tracing technique (TTT), is described in Appendix A.

7.5.3 RNAV area holding

The holding area shall contain the basic holding protection area rotated about the waypoint fix tolerance area described in 7.4.2.2. (See Figures III-3-7-1 B) and III-3-7-2.)

7.6 PROMULGATION OF RNAV HOLDING PROCEDURES

7.6.1 RNAV holding for RNAV systems with holding functionality

For this type of holding the outbound leg is defined by its length. The outbound length shall be published on the approach chart expressed in kilometres (nautical miles).

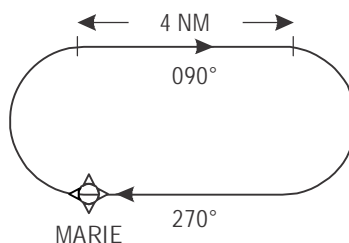

7.6.2 RNAV holding for all RNAV systems

7.6.2.1 For holding flown manually the outbound leg is either defined by a timing or a distance from the holding waypoint.

7.6.2.2 Where the two types of RNAV holding patterns (both the ones to be flown manually and the ones with holding functionality) are possible on the same waypoint, the length of the outbound leg and either the timing or WD shall be published.

7.6.2.3 For holding coded in a system with holding functionality, the outbound leg distance to be coded shall be provided in the procedure description tabular form on the verso of the chart or on a separate, properly referenced sheet (see the example below).

Example:

<i>Path descriptor</i>	<i>Fix identifier (waypoint name)</i>	<i>Inbound course °M (°T)</i>	<i>Leg distance</i>	<i>Turn direction</i>	<i>Minimum altitude</i>	<i>Maximum altitude</i>	<i>Speed limit</i>	<i>Magnetic variation</i>	<i>Navigation specification</i>
Hold	POLIN	270 (272.3)	4.0	R	2 000	6 000	250	-2.3	RNAV 1

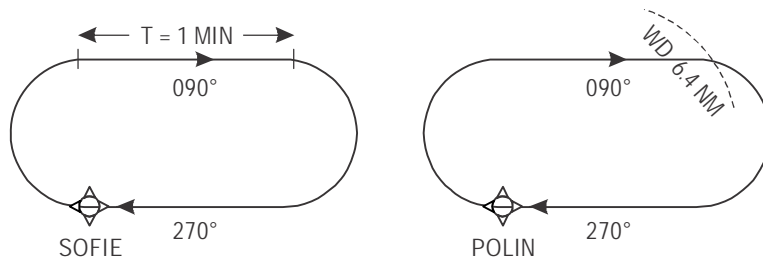

7.6.2.4 Where the outbound leg is defined by a distance from the holding waypoint, the waypoint distance (WD) shall be published on the approach chart expressed in tenths of kilometres (tenths of nautical miles).

Note.— The holding waypoint may not be charted as a flyover waypoint, but the pilot and/or aircraft navigation system is expected to treat the waypoint as a flyover waypoint while flying the holding (see Appendix A for background and rationale).

7.6.2.5 See Appendix B for the definition of RNAV sectors.

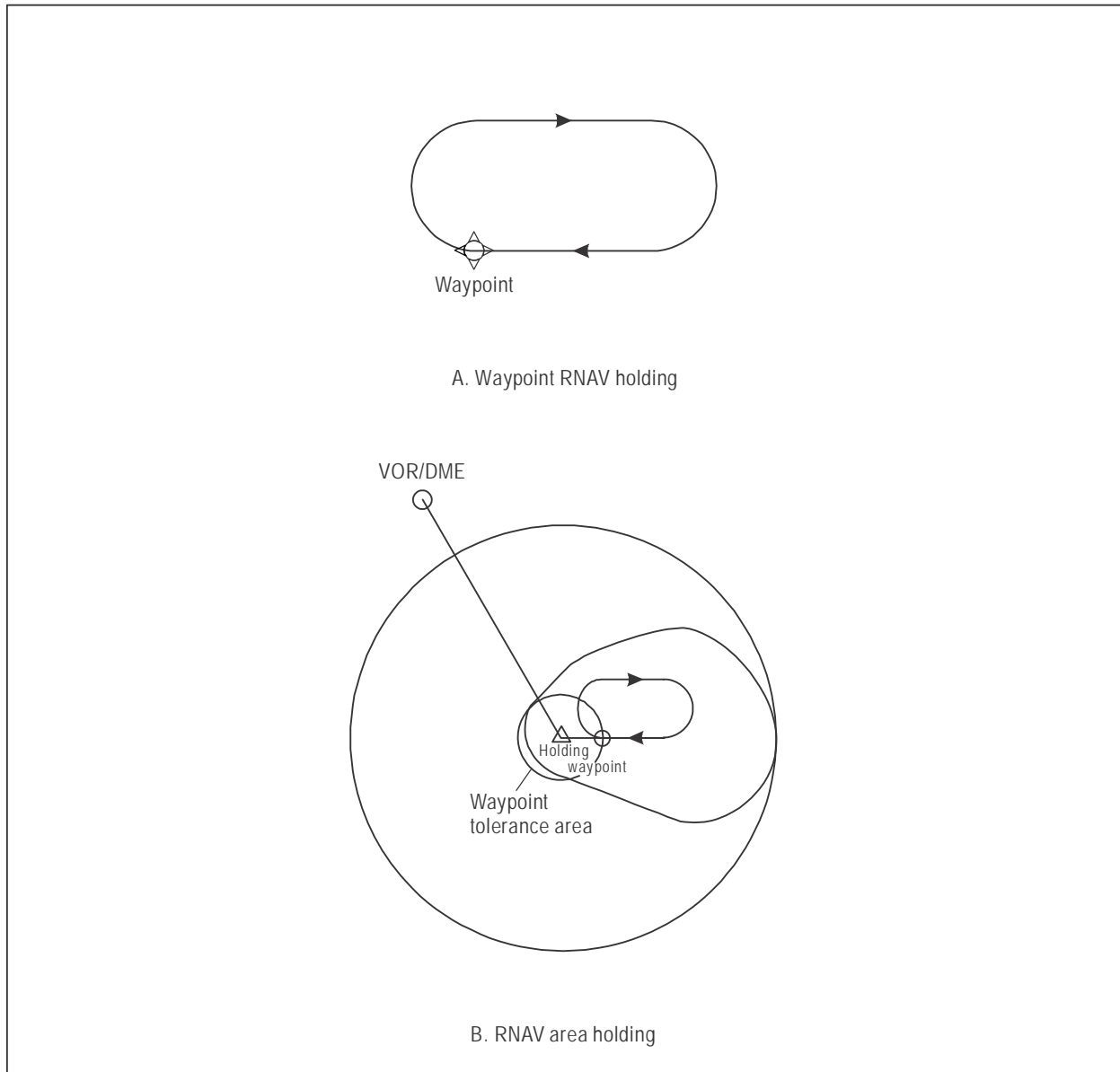

Figure III-3-7-1. Types of RNAV holding procedures

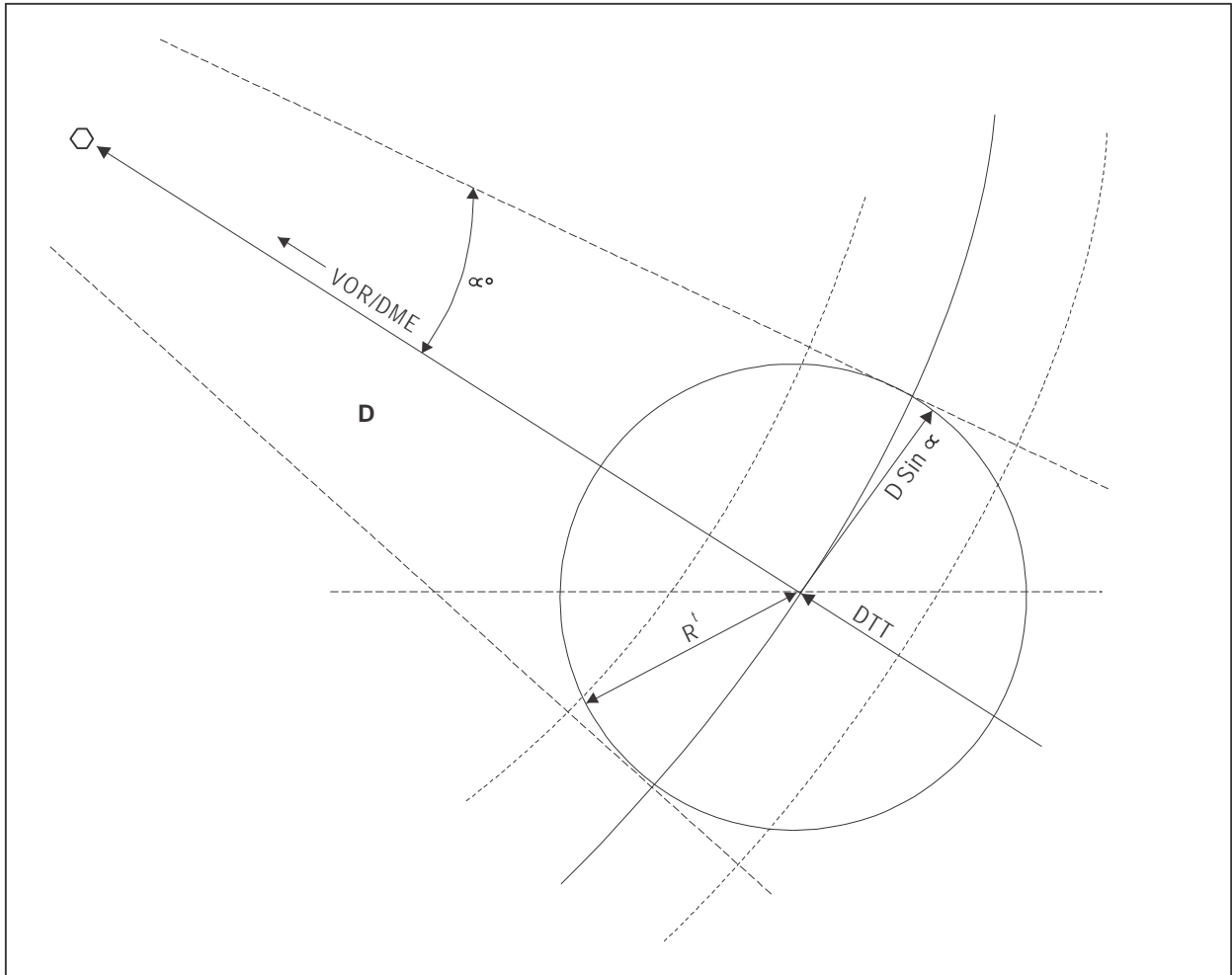

Figure III-3-7-2. Construction of waypoint tolerance areas

Appendix A Chapter 7

CONSTRUCTION OF OBSTACLE CLEARANCE AREA FOR VOR/DME, DME/DME AND GNSS RNAV HOLDING

1. GENERAL

The holding area construction is broken down into the following three steps:

- a) construction of the template;
- b) basic area construction; and
- c) construction of entry area.

2. CONSTRUCTION OF THE TEMPLATE

2.1 RNAV systems with holding functionality

Construct an RNAV holding template using the following guidelines (see Figure III-3-7-App A-1 as an example):

- a) choose the outbound distance: D is the length of the outbound leg; D shall be at least equal to one diameter of turn rounded to the next higher km (NM);
- b) draw the nominal trajectory; locate point “i” at the end of the outbound leg;
- c) draw the protection of a turn of more than 180° as for a conventional template (see Diagram I-4-3-App C-6 in Part I, Section 4, Chapter 3, Appendix C);
- d) draw a parallel to the outbound track tangent to line (2);
- e) from “i”, draw a perpendicular to the outbound track;
- f) lines (3) and (4) intercept at i1;
- g) place conventional template point “a” on “i”, then on “i1”, with axis parallel to the outbound leg and, in both cases, draw the protection of a turn of more than 180°; draw the tangent T to these protections;
- h) draw the tangent T1 between line (6) and line (2);
- i) draw the tangent T2 between line (2) and (6); and

- j) locate point E on the template (see Part I, Section 4, Chapter 3, Appendix C, 3.3.2.2.4.7) and use the following formulas for XE and YE (which are different from those in Part I, Section 4, Chapter 3, Appendix C, 3.3.2.2.4.7):

$$XE = 2r + D + 11v + \left(11 + \frac{90}{R} + 11 + \frac{105}{R}\right)W'$$

$$YE = 11v \cdot \cos 20^\circ + r \cdot \sin 20^\circ + r + \left(11 + \frac{20}{R} + \frac{90}{R} + 11 + \frac{15}{R}\right)W'$$

(See Figures III-3-7-App A-2 a) and III-3-7-App A-2-b.)

2.2 RNAV systems without holding functionality

Construct a conventional holding template according to Part I, Section 4, Chapter 3, Appendix C, 3.3.2.

3. CONSTRUCTION OF THE BASIC AREA

3.1 Holding point tolerance area

Draw around holding point A the RNAV fix tolerance associated with the waypoint and locate points A1, A2, A3 and A4 on the four corners of this area.

3.2 Basic area construction

3.2.1 RNAV system with holding functionality

(See Figure III-3-7-App A-3.)

- place the RNAV template point “a” successively on A1, A2, A3 and A4 to draw curves “1”, “2”, “3” and “4”; and
- draw the common tangents to curves “1” and “2”, “2” and “4”, “3” and “4”, “3” and “1”.

3.2.2 RNAV systems without holding functionality

3.2.2.1 Outbound leg of the holding defined by timing (See Figure III-3-7-App A-4.)

- place the conventional template point “a” successively on A1, A2, A3 and A4 to draw curves “1”, “2”, “3” and “4”;
- draw the common tangents to curves “1” and “2”, “2” and “4”, “3” and “4”, “3” and “1”.

3.2.2.2 Outbound leg of the holding defined by distance (See Figure III-3-7-App A-5.)

3.2.2.2.1 *Protection of the outbound turn and the outbound leg*

- a) place the conventional template point “a” on A1, with axis parallel to the inbound track, and draw curve “1” (part of the outline of the template) and circle with centre “g” and radii W_G ;
- b) place the conventional template point “a” on A3, with axis parallel to the inbound track, and draw curve “2” (part of the outline of the template) and line “3” (protection of the outbound leg in the direction of the non-maneuvring side); and
- c) draw the common tangent to curves “1” and “2” and extend the straight part of curve “1” and the line “3” in the direction of the outbound end.

3.2.2.2.2 *Calculation of the limiting outbound distance: WD*

WD is the distance between the holding waypoint and the vertical projection of the end of the outbound track onto the WGS-84 ellipsoid.

The distance parameters are chosen and calculated in the following sequence:

- a) choice of the outbound length: ds

ds is the horizontal length of the outbound leg; ds should conform to the relationship $ds > vt$, where t is the outbound timing, as specified in Part I, Section 4, Chapter 3, 3.5.5, “Outbound time” for racetrack procedures and in Part II, Section 4, Chapter 1, 1.3.2.2, “Outbound timing” for holding procedures;

- b) calculation of the limiting outbound distance: WD

WD is the horizontal distance between the holding point and the vertical projection of the end of the outbound track.

$$WD = (ds^2 + 4r^2)^{1/2}$$

- c) minimum value for WD

Additionally, in order to guarantee that this distance does not cross the area containing the end of the outbound turn, the limiting outbound distance is such that it does not cross the area containing the end of the outbound turn. Practically, a circle with centre “holding point” and radius WD shall not interfere with the circle with centre “g” and radii W_G as drawn as described in 3.2.2.2.1 a).

If the distance calculated in point b) is such that an interference occurs, the WD shall be increased up to a value complying with these criteria.

Note.— The minimum value of WD complying with these criteria may also be determined using the formula:

$$WD = [(ATT+11v)^2 + (2r+XTT)^2]^{1/2} + Wg$$

- d) WD is then rounded to the next higher tenth of a km (or NM).

3.2.2.2.3 *Area containing the end of the outbound leg*

- a) draw from A the inbound track “RP” and two lines “RP1” and “RP2” at a distance equal to XTT on each side of it:

where XTT is the holding point cross-track tolerance;

- b) with centre on A, draw arcs “D” with a radius WD, “D1” with a radius WD-ATT, “D2” with a radius WD + ATT:

where ATT is the holding point along-track tolerance;

- c) locate point C1 at the intersection of the extension of curve “1” with the arc D2;
- d) locate points C2 and C3 at the intersection of the extension of line “3” with arcs D1 and D2; and
- e) if the aircraft intercepts the RNAV holding inbound track before reaching the limiting outbound distance WD, the pilot is assumed to follow outbound the RNAV track without drifting any further from the procedure axis, so:

where C2 and C3 are further from the procedure axis than RP2 (see Figure III-3-7-App A-6 a)), replace C2 and C3 by the intersection of RP2 with arcs D1 and D2 respectively; and

where C3 only is further from the procedure axis than RP2 (see Figure III-3-7-App A-6 b)), replace C3 by the intersection of RP2 with D2, add point C’2 at the intersection of line “3” with RP2.

3.2.2.3 Protection of the inbound turn

Rotate the template 180°, then:

- a) place template point “a” on C1, with axis parallel to the inbound track, and draw curve “4” (part of the protection line of a turn of more than 180°);
- b) move the template point “a” along arc D2 from C1 to C3 (with axis parallel and opposite to the inbound track) and draw curve “5”;
- c) place template point “a” on C2, C3 and eventually on C’2 and draw curves “6”, “7” and eventually “8” and their common tangent; and
- d) draw the tangent to curve “7” and “2”.

4. CONSTRUCTION OF THE ENTRY AREAS

4.1 RNAV system with holding functionality

(See Figure III-3-7-App A-7.)

Draw the circle centred on “A” passing through A1 and A3; apply the same method as explained in Part I, Section 4, Chapter 3, Appendix C, 3.3.3.2.1, using the RNAV holding template.

4.2 RNAV system without holding functionality

4.2.1 Outbound leg of the holding defined by timing

(See Figure III-3-7-App A-8.)

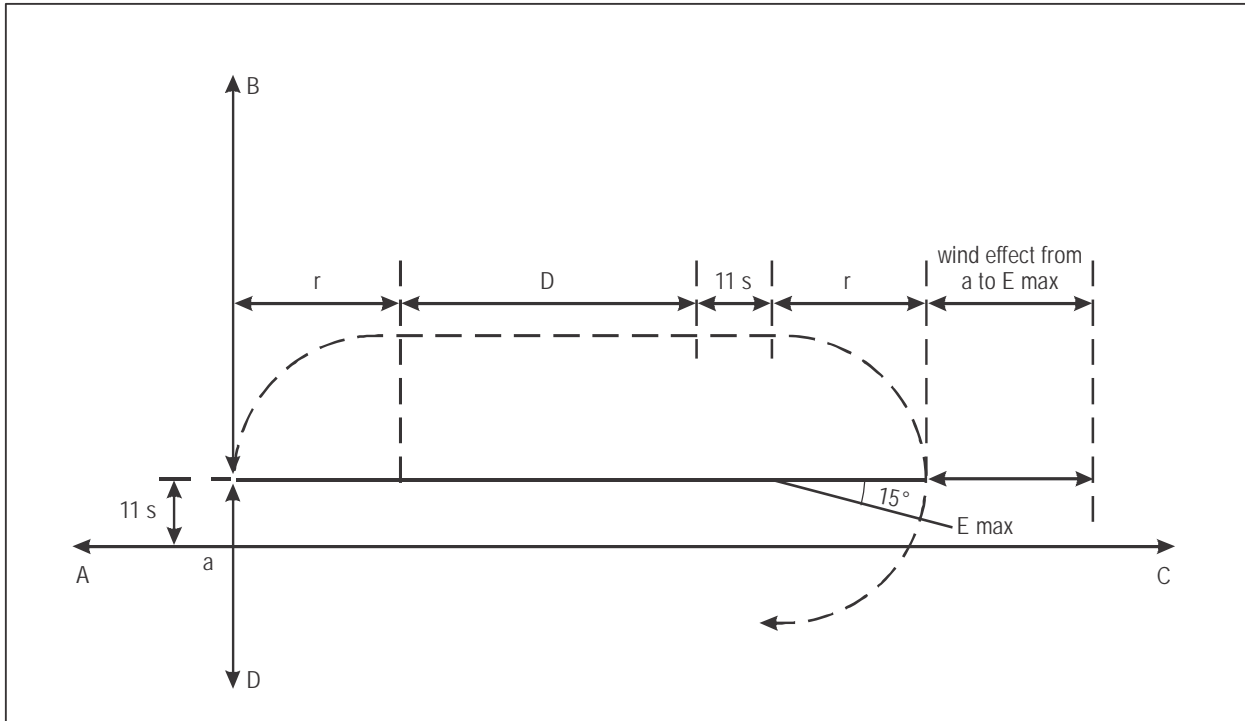

Figure III-3-7-App A-2a). RNAV holding: XE calculation

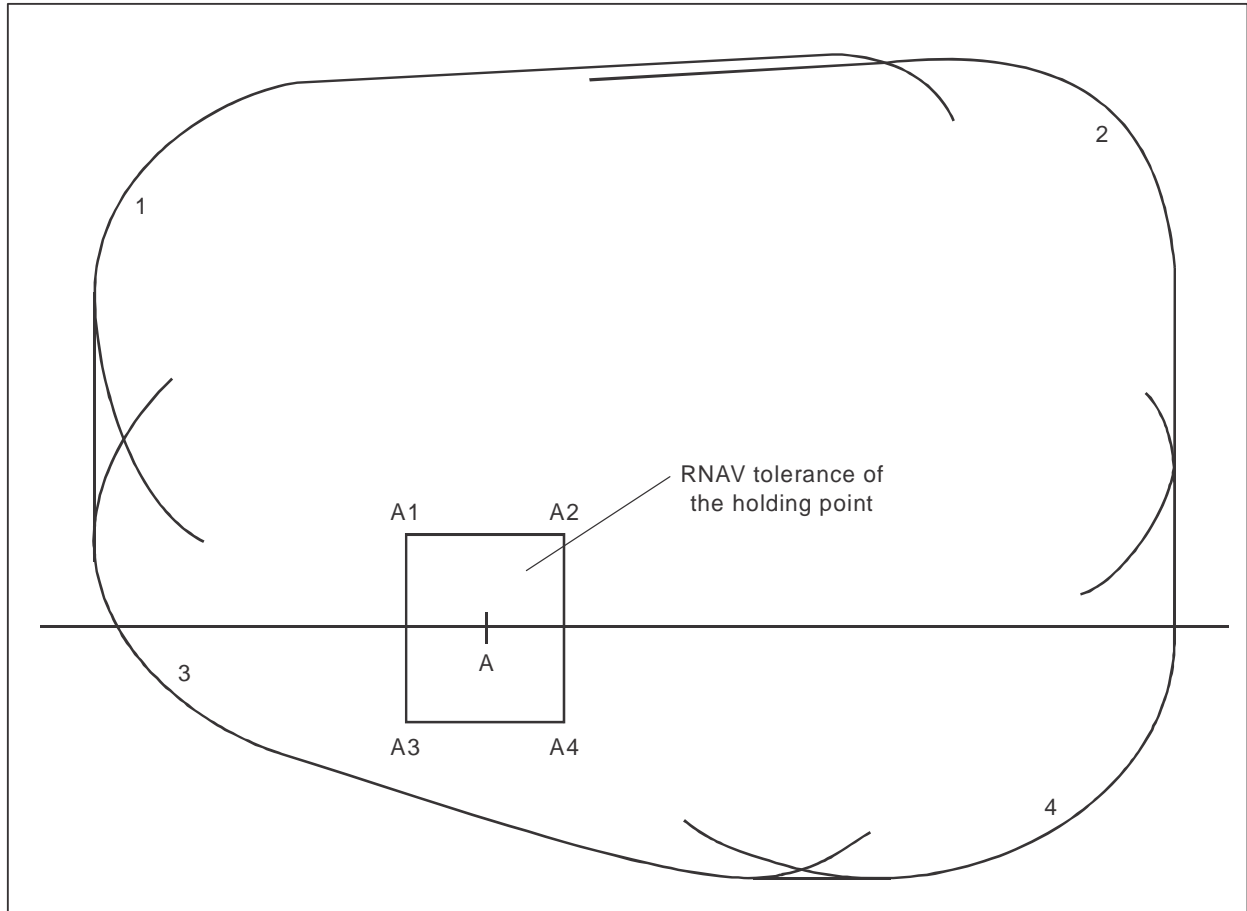

Figure III-3-7-App A-3. RNAV basic area for RNAV system with holding functionality

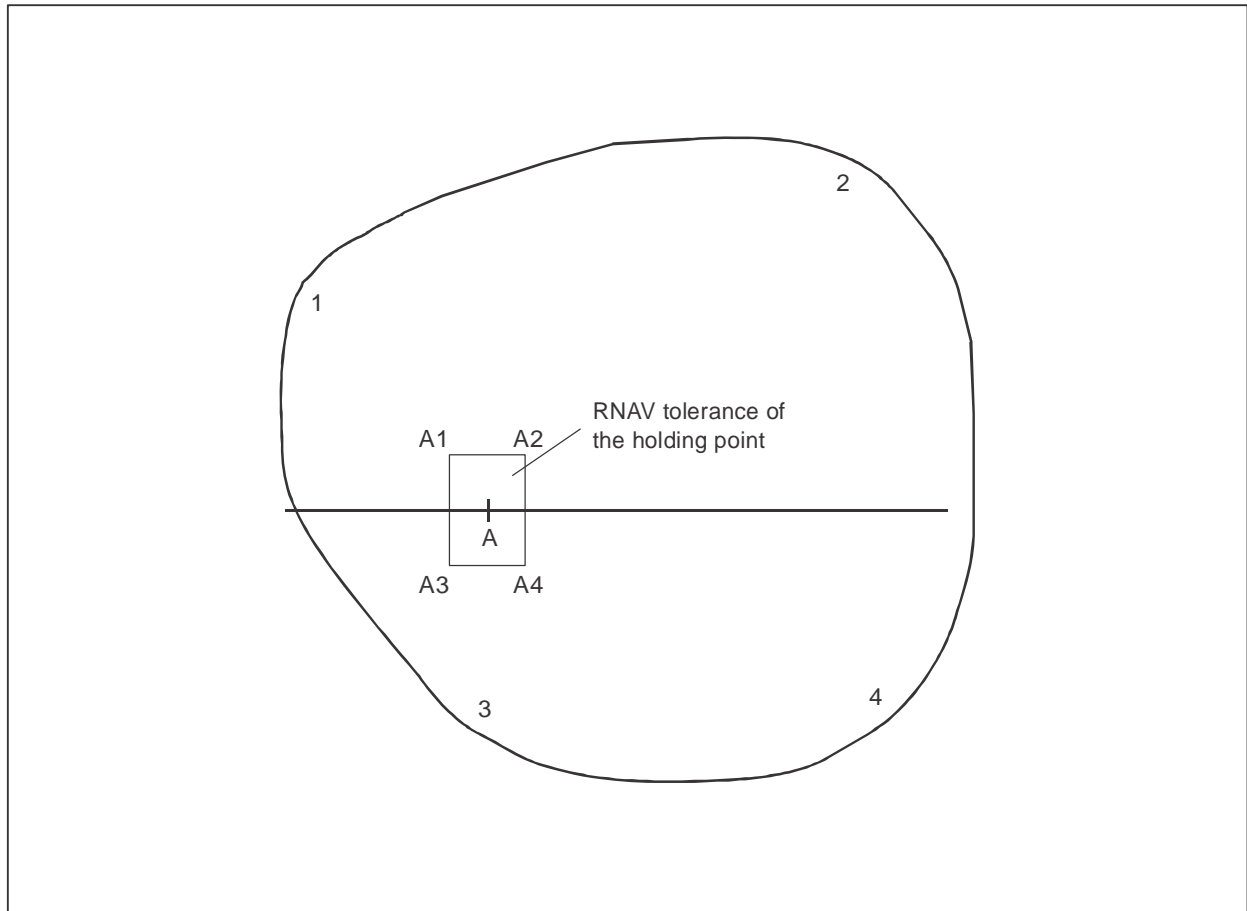

Figure III-3-7-App A-4. RNAV holding basic area for RNAV system without holding functionality — outbound leg defined by timing

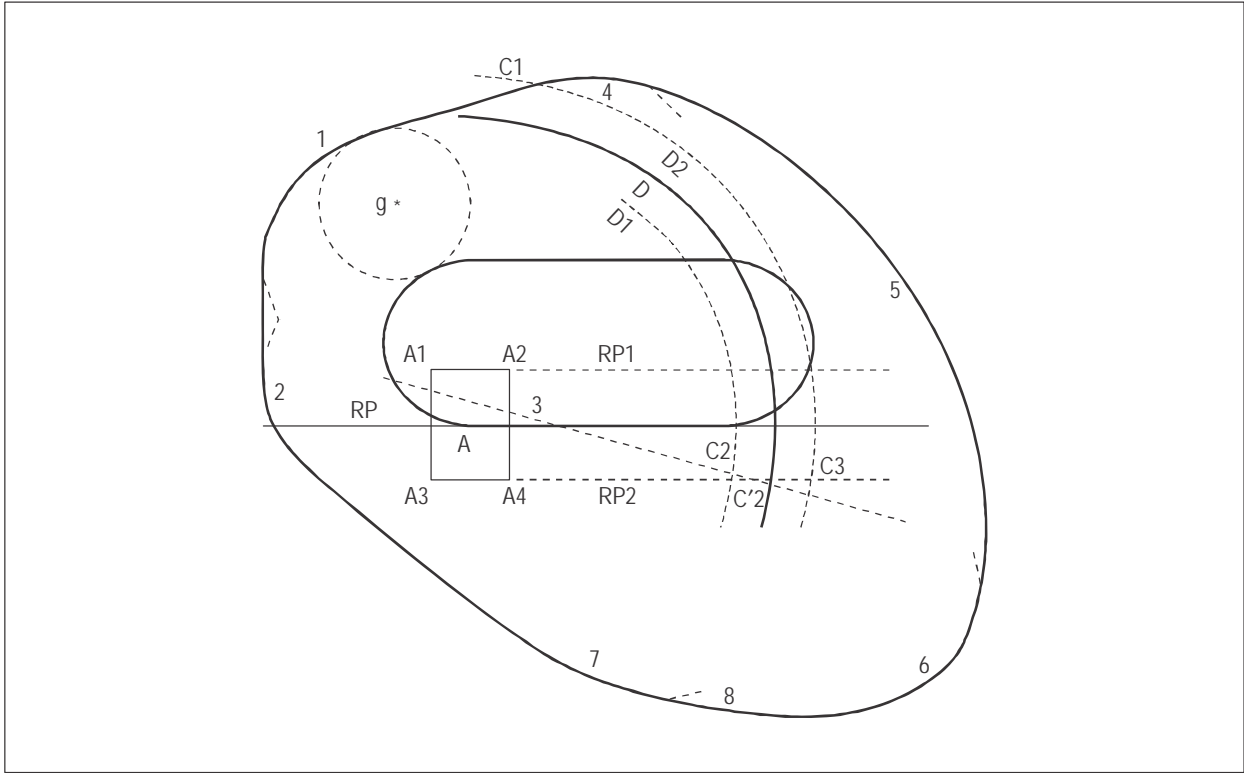

Figure III-3-7-App A-5. RNAV holding basic area for RNAV system without holding functionality — outbound leg defined by distance

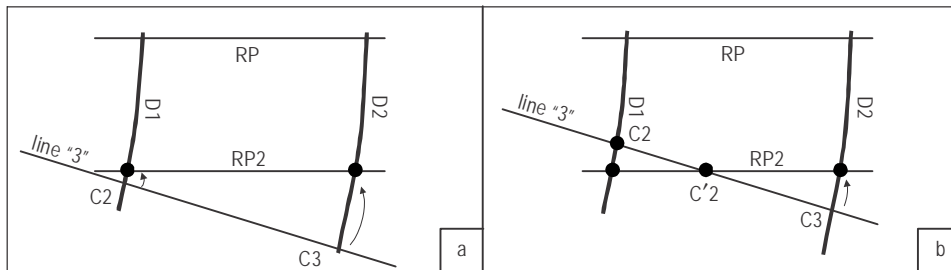

Figure III-3-7-App A-6. Area containing the end of the outbound leg (see 3.2.2.2.3 e))

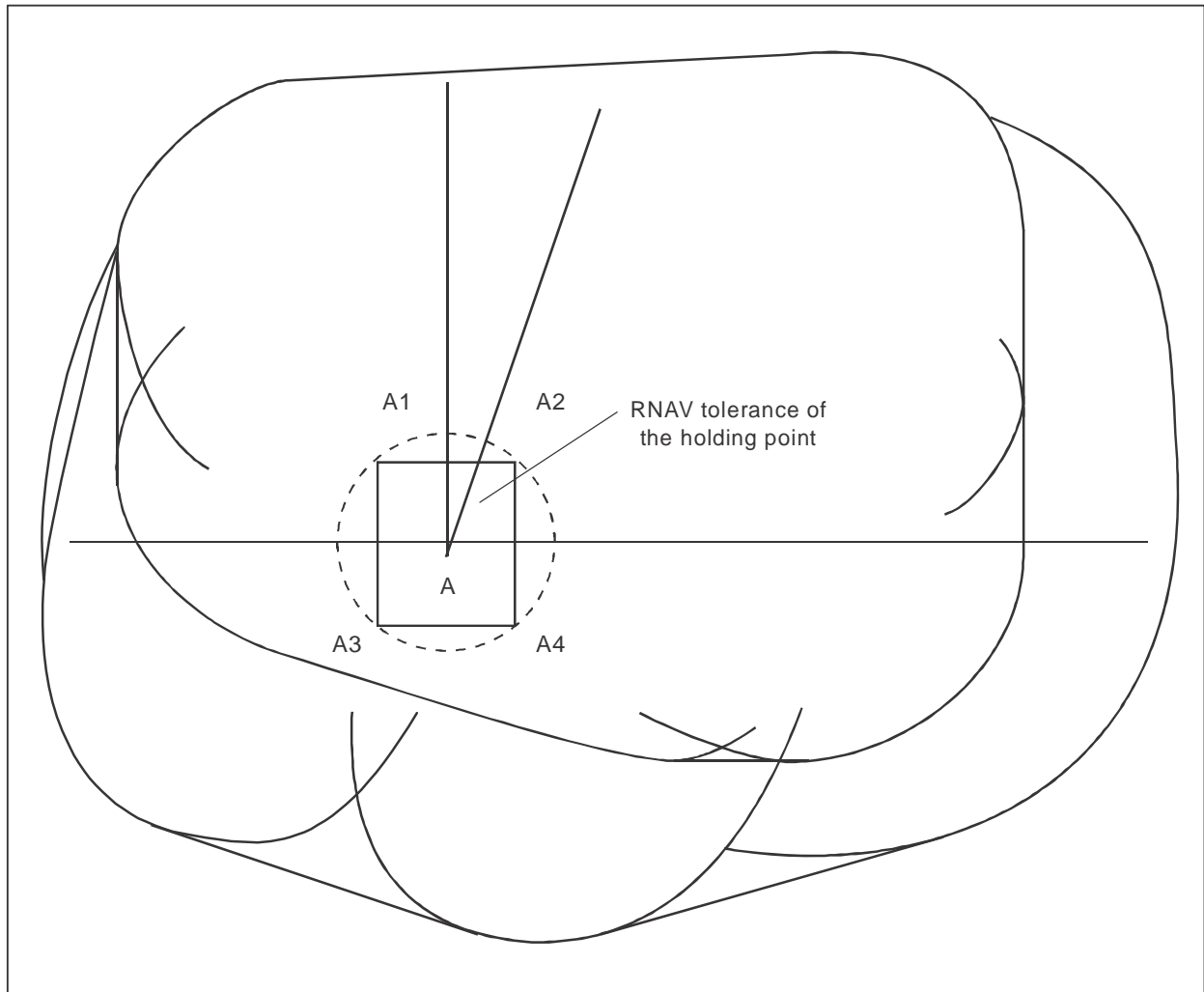

Figure III-3-7-App A-7. RNAV holding area including protection of entry procedures for RNAV system with holding functionality

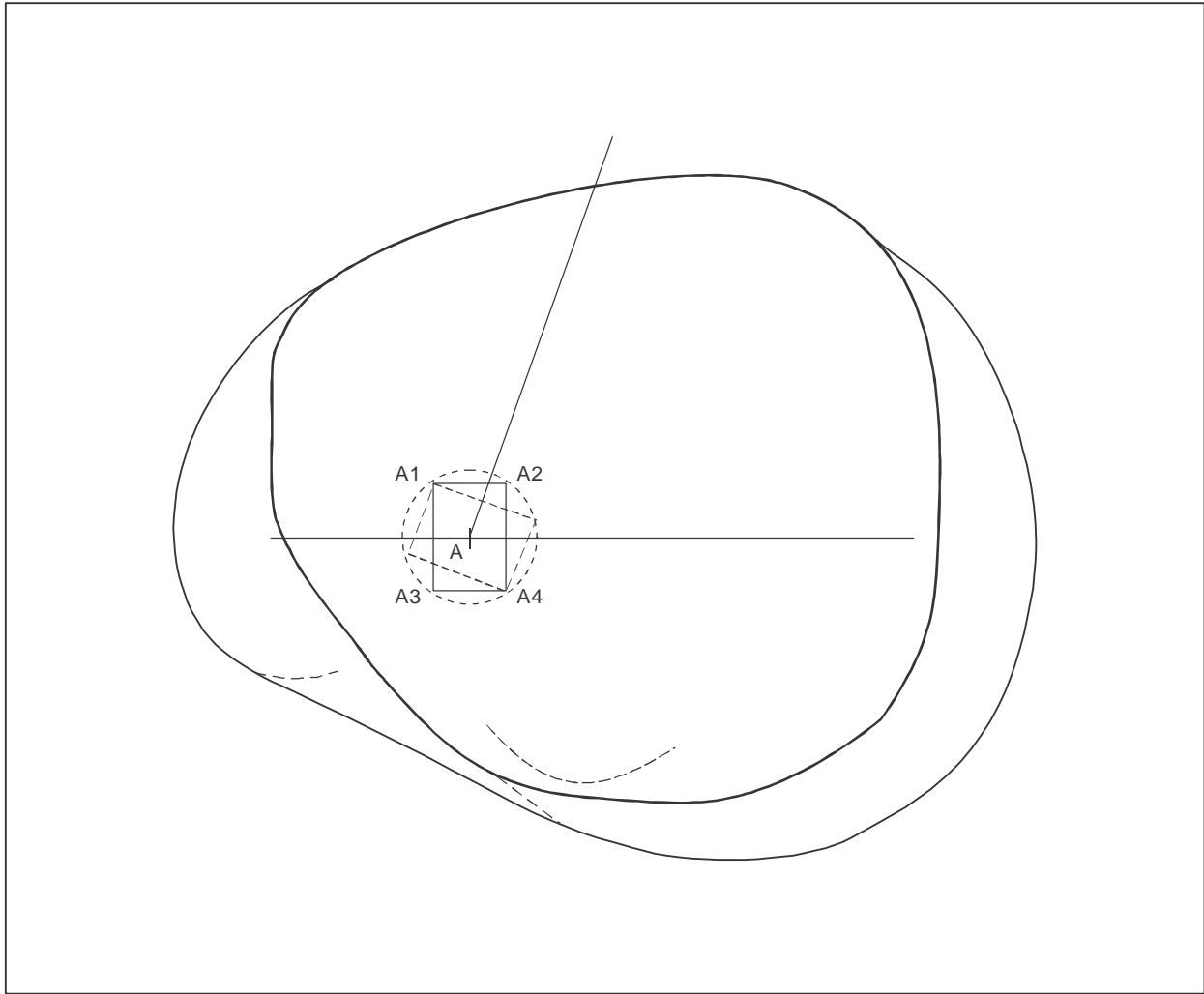

Figure III-3-7-App A-8. RNAV holding area including protection of entry procedures for RNAV system without holding functionality — outbound leg defined by timing

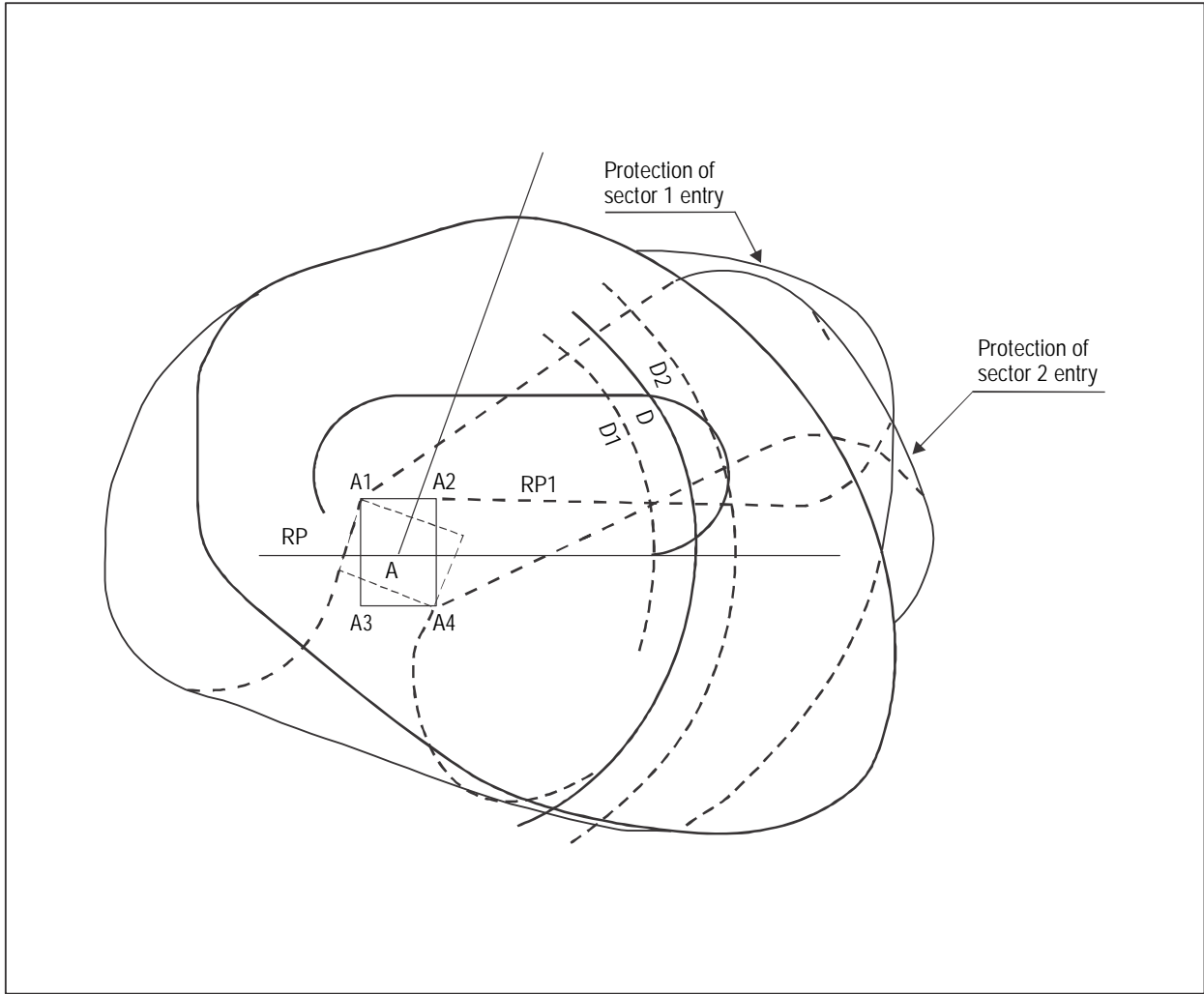

Figure III-3-7-App A-9. RNAV holding area including protection of entry procedures for RNAV system without holding functionality — outbound leg defined by distance

Appendix B Chapter 7

EXAMPLE OF ALTERNATIVE AREA NAVIGATION (RNAV) HOLDING ENTRIES FOR REDUCED HOLDING ENTRY AREAS

1.1 INTRODUCTION

1.1.1 Conventional entries described in Part II, Section 4, Chapter 1 are based on the fact that for VOR or NDB procedures, it is necessary to overfly the station or holding fix at the beginning of the entry. This requires additional protection for entry procedures with these types of holdings.

1.1.2 With a suitable RNAV system, it is no longer necessary to overfly the station or holding waypoint. This Attachment gives an example of alternative entries which are less “space consuming” than the conventional ones. This material is presented for the purpose of information to manufacturers. A date for operational use will be established in the future.

1.2 DEFINING THE ENTRY SECTORS

- a) Draw the outline of the holding pattern (see Figure III-3-7-App B-1); and
- b) draw a line making an angle of 70° with the axis of the inbound leg through the holding waypoint.

These two lines divide the space into four sectors: (1, 2, 3 and 4) as shown.

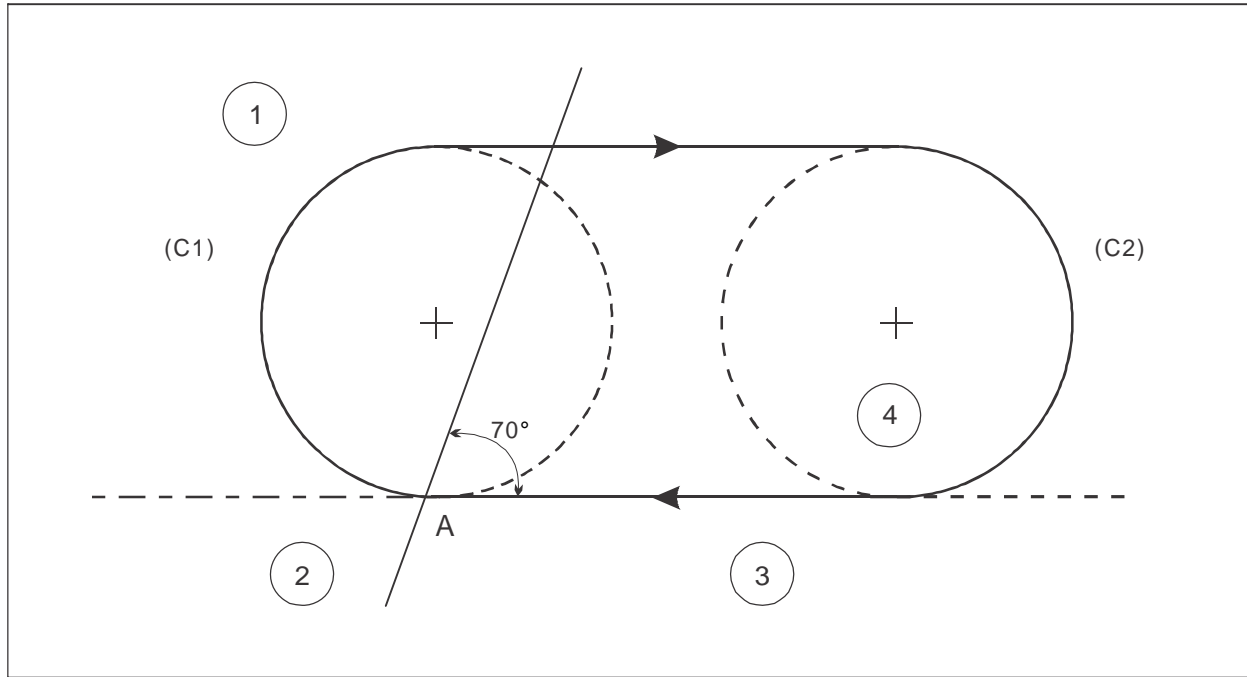

Figure III-3-7-App B-1. Entry sectors

Chapter 8

EN-ROUTE PROCEDURES

8.1 GENERAL

8.1.1 Application

8.1.1.1 This chapter describes the en-route criteria for RNAV 5, RNP 4, RNAV 2 and RNAV 1. The general criteria of Part II, Section 3, “En-route criteria” apply with the following modification: on the straight segments, the area has a constant width (angular limits do not apply).

8.1.1.2 The general criteria of Part I and Part III, Sections 1 and 2, as amplified or modified by the criteria in this chapter, apply.

8.1.2 Secondary areas

The general criteria for secondary areas apply (see Part I, Section 2, Chapter 1, 1.2 and 1.3).

8.1.3 Area widths

For the calculation of area widths and the underlying tolerances involved in these calculations, see the paragraph entitled “XTT, ATT and area semi-width” in Part III, Section 1 for the appropriate sensor. These are:

- a) GNSS, Section 1, Chapter 2, 2.2;
- b) DME/DME, Section 1, Chapter 3, 3.6; and
- c) VOR/DME, Section 1, Chapter 4, 4.6.

The total area width results from joining the various area widths at the relevant fixes, with the exception of the interfaces between the en-route segment and the initial approach segment, and between the en-route segment and the departure segment where the methodology detailed in Part III, Section 1, Chapter 1, 1.4 should be applied.

8.1.4 Definition of turns

The turn at a fly-by waypoint is the only turn allowed in en-route RNAV operations.

8.1.5 Turn at a fly-by waypoint

8.1.5.1 *General*

For turn protection and obstacle assessment see Section 2, Chapter 2, 2.3, “Wind spiral/Bounding circles method.”

8.1.6 Minimum altitudes

See Part II, Section 3, Chapter 1.

Section 4
QUALITY ASSURANCE

(To be developed)

Section 5
PUBLICATION

Chapter 1

PUBLICATION AND CHARTING — GENERAL

1.1 INTRODUCTION

The general criteria in Part I, Section 3, Chapter 5, “Published Information for departure procedures”, and Part I, Section 4, Chapter 9, “Charting/AIP” apply as modified in this chapter. See Chapter 2 for specific aeronautical database publication requirements.

1.2 NOTIFICATION OF DIFFERENCES IN AIP

The obstacle protection afforded to PBN procedures is, in most cases, predicated upon a ground track. This track is defined by a number of parameters including, inter alia, waypoint location and type, vertical path angle, maximum speed, minimum altitude, minimum bank angle and the path terminator associated with each procedure leg. If some of these parameters differ from the ICAO Standards, Recommended Practices and Procedures, they should be specified as generic to all PBN procedures with a clear statement in the GEN section of the AIP (See Annex 15, Appendix 1, Part 1, GEN 1.7).

1.3 DEPARTURES AND ARRIVALS

1.3.1 *Chart titles.* Charts shall be titled in accordance with Annex 4, 2.2. The required navigation specification for any published procedure shall be published in the State AIP, either on the chart or in the ENR 1.5 section.

1.3.2 Chart identification

1.3.2.1 The chart shall be identified in accordance with Annex 4, 9.5 for departures and 10.5 for arrivals and shall include the term RNAV or RNP, depending on the navigation specification.

1.3.2.2 The chart should include an identifier which is unique for that aerodrome and which may include reference to either a runway, fix or NAVAID.

1.3.3 Route designation

1.3.3.1 Each route shall be assigned a designator that is unique for that aerodrome. The designator shall be defined in accordance with Annex 11, Appendix 3. In addition, the first 4 letters of any 5LNC used in a route designator shall be unique for the aerodrome.

Note 1.— Airborne navigation databases use a maximum of 6 characters to identify a route. If the coded route designator is longer than 6 characters, the fifth character of the 5 LNC is not coded in navigation database route designation.

Note 2.— The coded route designator and the navigation specification name may be charted alongside the route in the plan view.

1.3.3.2 Separate charts should be published only if the routes differ laterally or vertically. When operationally required, separate charts may be published for each sensor or for a combination of sensors.

1.3.4 *Chart notes.* Additional procedure requirements shall be provided as chart notes. PBN items shall be separated out and published in a PBN requirements box on the plan view of the chart immediately below the chart identifier. The PBN requirements box shall include the identification of the navigation specification used in the procedure design, any navigation sensor limitations and any required functionalities that are described as options in the navigation specification, that is, not included in the core navigation specification as follows:

a) Navigation specification:

— RNAV 5

— RNAV 1

— RNP 1

— Advanced RNP (RNP navigation accuracies shall be specified, e.g. RNP 2, RNP 1)

— RNP 0.3

b) Navigation sensor limitations, e.g:

— GNSS required

c) Functional requirements:

— RF required.

Note.— Lengthy text may be shown on the verso of the chart.

1.3.5 Depiction

The RF leg shall be depicted as shown in Figure III-5-1-2 below. The along track distance of the RF leg shall be charted but no course value shall be shown on the RF leg. The radius and the arc centre shall not be charted but shall be included in the procedure description.

1.4 APPROACH

1.4.1 *Chart titles.* Charts shall be titled in accordance with Annex 4, 2.2.

1.4.2 Chart identification

1.4.2.1 The chart shall be identified in accordance with Annex 4, 11.6.

1.4.2.2 Until 30 November 2022, approach charts depicting procedures that meet the RNP APCH navigation specification criteria shall include the term RNAV_(GNSS) in the identification (e.g. RNAV_(GNSS) RWY 23) or, alternatively, as described in 1.4.2.3.

Note.— ICAO Circular 336 provides guidance to assist States and other stakeholders with the transition from RNAV to RNP approach chart identification.

1.4.2.3 From 1 December 2022, charts depicting procedures that meet the RNP APCH navigation specification criteria shall include the term RNP in the identification (e.g. RNP RWY 23). The identification shall also include a parenthetical suffix when exceptional conditions occur as described in Table III-5-1-1.

Table III-5-1-1. Conditions when suffix shall be applied in chart designation

<i>Condition</i>	<i>Suffix</i>	<i>Example</i>
Procedure has only an LPV line of minima	LPV only	RNP RWY 23 (LPV only)
Procedure has only an LNAV/VNAV line of minima	LNAV/VNAV only	RNP RWY 23 (LNAV/VNAV only)
Procedure has both LPV and LNAV/VNAV lines of minima but no LNAV minima	LPV, LNAV/VNAV only	RNP RWY 23 (LPV, LNAV/VNAV only)
Procedure has only an LP line of minima	LP only	RNP RWY 23 (LP only)

1.4.2.4 Until 30 November 2022, charts depicting procedures that meet the RNP AR APCH navigation specification shall include the term RNAV_(RNP) in the identification (e.g. RNAV_(RNP) RWY 23) or, alternatively, as described in 1.4.2.5.

Note.— ICAO Circular 336 provides guidance to assist States and other stakeholders with the transition from RNAV to RNP approach chart identification.

1.4.2.5 From 1 December 2022, charts depicting procedures that meet the RNP AR APCH navigation specification shall include the term RNP in the identification with a parenthetical suffix (AR). (e.g. RNP RWY 23 (AR)).

1.4.2.6 The chart identification shall include the runway identification for straight-in landing, or a letter designator (a, b, c, etc.) for circling approach (see Part I, Section 4, Chapter 9).

1.4.2.7 When more than one PBN approach procedure exists for the same runway, the duplicate identification criteria defined in Part 1, Section 4, Chapter 9 apply. When a PBN approach procedure is combined with another PBN approach procedure on the same chart, the multiple procedure criteria defined in Part 1, Section 4, Chapter 9 apply.

Note.— The text in parentheses that is part of the procedure identification does not form part of the ATC clearance.

1.4.3 *Chart notes.* When amending or publishing new PBN approach procedures, additional procedure requirements shall be provided as chart notes. PBN items shall be separated out and published in a PBN Requirements Box which includes the identification of the navigation specification used in procedure design and any optional requirements that are not included in the core navigation specification as specified as follows:

a) Navigation specifications:

- RNAV 1
- RNP 1
- RNP APCH
- RNP AR APCH
- Advanced RNP
- RNP 0.3

b) Optional requirements:

- RNP APCH: RF required
- RNP AR APCH: RF required, RNP < 0.3, Missed approach RNP < 1
- Advanced RNP: RNP < 1 in initial and intermediate segments
- RNP 0.3: RF required.

1.4.4 Depiction

1.4.4.1 Any RF requirement shall be charted in accordance with paragraphs 1.3.4 and 1.3.5 above.

1.4.4.2 Different RNP navigation accuracy requirements on different initial segment legs shall be charted with a note. The required note may be charted with the applicable leg, or as a procedure note with reference to the applicable leg. If the same RNP navigation accuracy applies to all initial and intermediate segments, then a general procedure note should be used as indicated in 1.4.3.

1.4.5 Minima

Minima for approach procedures shall be labelled on the chart as follows:

<i>Minima label</i>	<i>Associated navigation specification</i>
LNAV	RNP APCH
LNAV/VNAV	RNP APCH
LP	RNP APCH
LPV	RNP APCH
RNP 0.x	RNP AR APCH

1.5 FORMAL TEXTUAL OR TABULAR DESCRIPTION OF THE PROCEDURE

1.5.1 *General.* An accurate, complete and unambiguous RNAV procedure description is an essential publication requirement for database coding. This is accomplished by the combination of an appropriate chart, and an additional textual or tabular description of the procedure, to be used by the database coder. Where standard assumptions have been applied to the procedure design in areas such as speed and bank angle, there is no requirement to include these particular parameters in every procedure description.

1.5.2 An RNAV procedure is defined by one or a number of waypoints, each defined by a waypoint name, a path and terminator, and a set of constraints.

1.5.3 The textual or tabular description of the procedure, solely to support navigation database coding, shall incorporate all the data elements as specified in Chapter 2, and shall be published on the verso of the appropriate chart or as a separate properly referenced sheet (see Annex 4, 9.9.4.3, 10.9.4.3, and 11.10.9). In the following paragraphs three examples are provided (the formal, the abbreviated and the tabular description methods. The tabular description method is provided in Table III-5-1-3). The tabular description should be used when obstacle clearance is dependent upon the application of a particular path terminator.

1.5.4 *Formal textual description.* In the formal textual description, the following principles apply:

(Waypoint) (underlined) denotes flyover.

(Waypoint) (not underlined) denotes fly-by or RF waypoint as appropriate.

To (Waypoint) denotes a TF path terminator.

To (Waypoint) on course XXX° denotes a CF path terminator.

Direct to (Waypoint) denotes a DF path terminator.

(Waypoint) {R, NN.N, Arc Centre Identifier} denotes an RF path terminator, the radius and the centre point of a fixed radius turn in terminal airspace.

Climb on course XXX°, at or above yyy feet turn right/left denotes a CA path terminator.

From (Waypoint) on track XXX°, at or above yyy feet turn left/right denotes an FA path terminator.

Climb on heading XXX°, at or above yyy feet turn left/right denotes a VA path terminator.

Continue on heading XXX° denotes a VM path terminator.

Continue on track XXX° denotes an FM path terminator.

(Waypoint) {HM, Turn Direction, Inbound Track, Leg Distance/Time} denotes an HM path terminator.

The formal description method is illustrated in Table III-5-1-2.

1.5.5 Abbreviated description

1.5.5.1 The description may be abbreviated by placing the leg constraints (speed, track and altitude) in square brackets. If these constraints are not preceded by a waypoint name, the last calculated track shall be flown until the constraint is reached.

1.5.5.2 Each constraint is coded in the format UNNNNNCD where:

U may be one of the following letters:

A for altitude in feet AMSL

F for flight level

K for indicated air speed in knots

M for degrees magnetic

T for degrees true

NNNNN is a number from 000 to 99999

C may be one of the following:

“+” for ‘at or above’

“-” for ‘at or below’

a blank space for ‘at’

D is used to indicate turn direction in conditional and flyover transitions:

L for ‘Turn left’

R for ‘Turn right’

Multiple constraints should be separated by a semi-colon (;).

1.5.5.3 Individual waypoints in a procedure, together with their associated constraints, should be separated by a hyphen (-), except when the subsequent leg requires a DF path terminator when an arrow (→) should be used.

1.5.5.4 The formal description and the abbreviated description methods are illustrated in Table III-5-1-2.

1.6 WAYPOINT NAMING

Applicable from 19 November 2009

1.6.1 Waypoints used in support of RNAV SIDs, STARS and instrument approach procedures shall be designated by either a unique, five-letter, pronounceable “name-code” or a five-alphanumeric name-code. The following principles apply:

- a) waypoints shall be designated by a five-alphanumeric name-code only if they are used for waypoints unique to one aerodrome that has a properly assigned four-letter location indicator (in accordance with Doc 7910);
- b) in the following cases a unique, five-letter, pronounceable “name-code”, in accordance with Annex 11, shall be applied:
 - 1) final waypoint of a SID;
 - 2) initial waypoint of a STAR;
 - 3) waypoints common to more than one terminal control area or used in a procedure common to more than one airport which are not used for en-route; and
 - 4) waypoints for ATC purposes.

1.6.2 The following criteria apply when five-alphanumeric name-codes are used:

- a) the five-alphanumeric name-code convention that is adopted shall be applicable to all aerodromes within the State;
- b) the five-alphanumeric name-code should consist of no more than three numbers with the alphabetic characters being taken from the airport designator;
- c) the convention and the rules of application shall be published in the State AIP;
- d) the five-alphanumeric name-code shall be unique within the terminal area in which it is used;
- e) as global uniqueness cannot be assured, all waypoints that have a five-alphanumeric name-code identifier should be clearly listed as terminal waypoints in the AIP; and
- f) as global uniqueness cannot be assured for waypoints containing five-alphanumeric name-codes, to avoid any potential misselection by the pilot, ATC should not use waypoints designated by five-alphanumeric name-codes in any re-routing from the en-route structure into a terminal procedure.

1.7 ARC CENTRE AND SIGNIFICANT POINT COORDINATES

The WGS 84 coordinates of arc centres and significant points used in support of RNAV arrival, departure and instrument approach procedures shall be provided in tabular form as illustrated in Table III-5-1-4.

Table III-5-1-2. Illustration of the formal and the abbreviated description methods

<i>Formal description</i>	<i>Abbreviated description</i>	<i>Expected path terminator</i>	<i>Flyover required</i>
Climb on track 047°M, at or above 800 ft turn right.	[M047, A800+; R]	CA	N
Climb on heading 047°M, at or above 800 ft turn right.	[HDG M047, A800+, R]	VA	N
Direct to ARDAG at 3 000 ft	→ARDAG[A3000]	DF	N
To PF035 at or below 2 000 ft	PF035[A2000-]	TF	Y
To PF025 at or above 4 000 ft, continue on heading 265°M and await radar vectors.	PF025[A4000], [HDG, M265]	TF, VM or FM	N
To OTR on course 090°M at 210 kts	OTR[M090; K210]	CF	N
To DF006 at 2 000 ft minimum, 4 000 ft maximum, minimum speed 210 kts	DF006[A2000+; A4000-; K210+]	TF	Y
To PD750 at 250 kts, turn right with 3.7 NM radius to PD751	PD750[K250]-PD751[R, 3.7, 0543451.2N 0021234.7E]	TF, RF	N, N
To STO at or above FL 100, turn left direct to WW039 at or above FL 070, to WW038 at or above 5 000 ft	STO[F100+; L]→WW039[F070+]-WW038[A5000+]	TF, DF, TF	Y, N, N

Table III-5-1-3. Illustration of the tabular description method

<i>Serial Number</i>	<i>Path Descriptor</i>	<i>Waypoint Identifier</i>	<i>Fly-over</i>	<i>Course/Track M(°T)</i>	<i>Magnetic Variation</i>	<i>Distance (km)</i>	<i>Turn Direction</i>	<i>Altitude (m)</i>	<i>Speed (km/h)</i>	<i>VPA/TCH</i>	<i>Navigation Specification</i>
001	CA	—	—	221 (223.5)	-2.3	—	—	@150	—	—	B-RNP 1
002	DF	FOKSI	—	—	-2.3	—	R	—	—	—	B-RNP 1
003	TF	EF974	—	043 (045.7)	-2.3	12.0	—	+1 400	—	—	B-RNP 1
004	RF Centre: EF991 r =5.240 NM	EF975	—	—	-2.3	13.7	R	—	-450	—	B-RNP 1
005	TF	EF976	Y	145 (147.3)	-2.3	9.6	—	+1 550	—	—	B-RNP 1
006	TF	TARTO	—	110 (112.3)	-2.3	28.2	—	—	—	—	B-RNP 1

<i>Serial Number</i>	<i>Path Descriptor</i>	<i>Waypoint Identifier</i>	<i>Fly-over</i>	<i>Course M(°T)</i>	<i>Magnetic Variation</i>	<i>Distance (km)</i>	<i>Turn Direction</i>	<i>Altitude (m)</i>	<i>Speed (km/h)</i>	<i>VPA/TCH</i>	<i>Navigation Specification</i>
001	IF	SUSER	—	—	+2.2	—	—	+1 550	-470	—	RNP APCH
002	TF	EF974	—	048 (045.7)	+2.2	12.0	—	+1 400	—	—	RNP APCH
003	RF Centre: EF991 r =5.240 NM	EF975	—	—	+2.2	13.7	R	—	-450	—	RNP APCH
004	TF	EF976	—	348 (345.8)	+2.2	9.6	—	@900	-270	—	RNP APCH
005	TF	RW35L	Y	348 (345.8)	+2.2	9.3	—	@150	—	-3.0/50	RNP APCH
006	FA	RW35L	—	348 (345.8)	+2.2	—	—	+250	—	—	RNP APCH
007	DF	SUSER	Y	—	+2.2	—	L	+1 550	—	—	RNP APCH
008	HM	SUSER	—	048 (045.7)	+2.2	7.4	R	+1 550	-450	—	RNP APCH

Table III-5-1-4. Waypoint and arc centre coordinates examples

<i>Waypoint Identifier</i>	<i>Coordinates</i>
EF974	43°34'23.8N 116°22'54.7W
EF975	43°35'39.1N 116°20'27.9W
<i>RF Arc Centre Identifier</i>	<i>Coordinates</i>
EF991	43°32'58.2N 116°19'41.6W

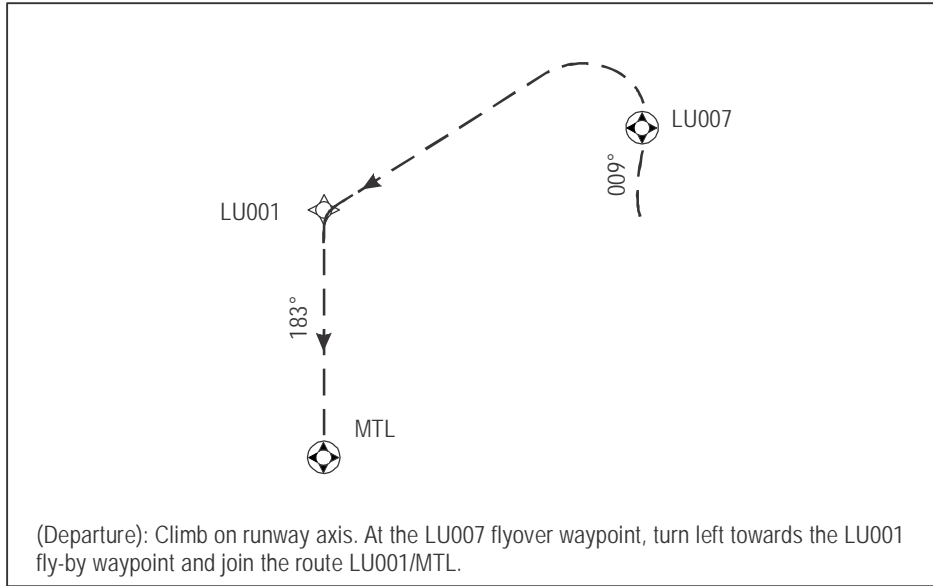

Figure III-5-1-1. Text description

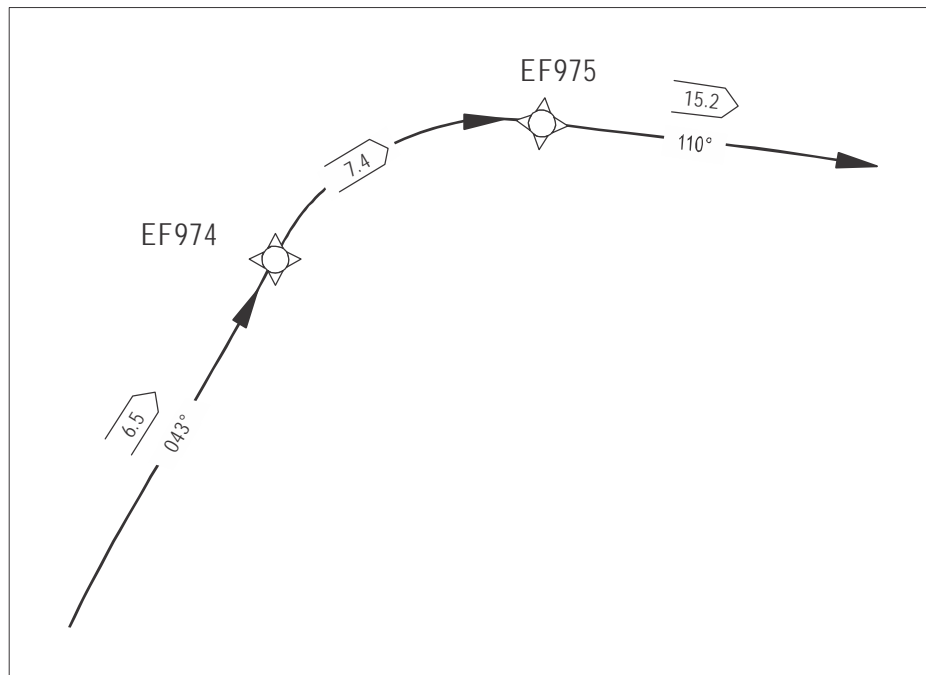

Figure III-5-1-2. RF leg depiction

Chapter 2

AERONAUTICAL DATABASE PUBLICATION REQUIREMENTS

2.1 For RNAV standard departure procedures — instrument (SID), the following data shall be published in tabular form or a formal textual description on the verso of the chart or a separate, properly referenced sheet (see Annex 4, 9.9.4.3):

- a) procedure designator;
- b) required navigation performance or basis for the approval applicable to the procedure;
- c) unambiguous description of the path and the method of termination of each specified segment;
- d) names, coded designators or name-codes and the geographical coordinates in degrees, minutes, seconds, and tenths of seconds, of all significant points defining the route, including annotation as to whether the significant point is fly-by or flyover;
- e) geodesic distance to the nearest tenth of a kilometre or tenth of a nautical mile between each successive designated significant point;
- f) true track to the nearest tenth of a degree and magnetic track to the nearest degree between each successive significant point;
- g) upper and lower altitude limit at a significant point, to the nearest higher 50 m or 100 ft/flight level, as applicable;
- h) speed limit at a significant point, expressed in units of 10 knots, as applicable;
- i) remarks; and
- j) associated RNAV holding procedure data including:
 - 1) holding identification (if any);
 - 2) holding fix (navigation aid) or waypoint with geographical coordinates in degrees, minutes, seconds, and tenths of seconds;
 - 3) inbound true track to the nearest tenth of a degree and magnetic track to the nearest degree;
 - 4) maximum indicated air speed expressed in units of 10 knots;
 - 5) minimum and maximum holding level to the nearest higher 50 m or 100 ft/flight level;
 - 6) time/distance to the nearest tenth of a kilometre or tenth of a nautical mile outbound; and
 - 7) direction of the turn.

2.2 For RNAV standard arrival procedures — instrument (STAR) the following data shall be published in tabular form or a formal textual description on the verso of the chart or a separate, properly referenced sheet (see Annex 4, 10.9.4.3):

- a) procedure designator;
- b) required navigation performance or basis for the approval applicable to the procedure;
- c) unambiguous description of the path and the method of termination of each specified segment;
- d) names, coded designators or name-codes and the geographical coordinates in degrees, minutes, seconds, and tenths of seconds, of all significant points defining the route, including annotation as to whether the significant point is fly-by or flyover;
- e) geodesic distance to the nearest tenth of a kilometre or tenth of a nautical mile between each successive designated significant point;
- f) true track to the nearest tenth of a degree and magnetic track to the nearest degree between each successive significant point;
- g) upper and lower altitude limit at a significant point, to the nearest higher 50 m or 100 ft/flight level, as applicable;
- h) speed limit at a significant point, expressed in units of 10 knots, as applicable;
- i) vertical path angle to the nearest one one-hundredth of a degree, as applicable;
- j) remarks; and
- k) associated RNAV holding procedure data including:
 - 1) holding identification (if any);
 - 2) holding fix (navigation aid) or waypoint with geographical coordinates in degrees, minutes, seconds, and tenths of seconds;
 - 3) inbound true track to the nearest tenth of a degree and magnetic track to the nearest degree;
 - 4) maximum indicated air speed expressed in units of 10 knots;
 - 5) minimum and maximum holding level to the nearest higher 50 m or 100 ft/flight level;
 - 6) time/distance to the nearest tenth of a kilometre or tenth of a nautical mile outbound; and
 - 7) direction of the turn.

2.3 For RNAV instrument approach procedures, the following data shall be published in tabular form or a formal textual description on the verso of the chart or a separate, properly referenced sheet (see Annex 4, 11.10.9):

- a) procedure designator;
- b) required navigation performance or basis for the approval applicable to the procedure;

- c) unambiguous description of the path, including, in the case of SBAS APV procedures, a textual representation of the FAS Data Block (as described in Appendix A to Part III, Section 2, Chapter 6; Appendix to Part IV, Chapter 3 and illustrated in Figure III-3-5-12), and the method of termination of each specified segment;
 - d) names, coded designators or name-codes and the geographical coordinates in degrees, minutes, seconds, and tenths of seconds, of all significant points defining the route, including annotation as to whether the significant point is fly-by or flyover;
 - e) geodesic distance to the nearest tenth of a kilometre or tenth of a nautical mile between each successive designated significant point;
 - f) true track to the nearest tenth of a degree and magnetic track to the nearest degree between each successive significant point;
 - g) upper and lower altitude limit at a significant point, to the nearest higher 50 m or 100 ft/flight level, as applicable;
 - h) speed limit at a significant point, expressed in units of 10 knots, as applicable;
 - i) final approach vertical path angle to the nearest one one-hundredth of a degree;
 - j) threshold crossing height to the nearest foot, as applicable;
 - k) remarks; and
 - l) associated RNAV holding procedure data including:
 - 1) holding identification (if any);
 - 2) holding fix (navigation aid) or waypoint with geographical coordinates in degrees, minutes, seconds, and tenths of seconds;
 - 3) inbound true track to the nearest tenth of a degree and magnetic track to the nearest degree;
 - 4) direction of the turn;
 - 5) maximum indicated air speed expressed in units of 10 knots;
 - 6) minimum and maximum holding level to the nearest higher 50 m or 100 ft/flight level; and
 - 7) time/distance to the nearest tenth of a kilometre or tenth of a nautical mile outbound.
-

Attachment to Part III

DERIVATION OF THE SBAS OBSTACLE ASSESSMENT SURFACES (OAS)

1. ASSUMPTIONS

The methodology behind the derivation of the SBAS OAS is based on the following assumptions:

- a) the signal-in-space performances meet the Annex 10, Volume I, requirements;
- b) the GNSS avionics meet the requirements of RTCA DO-229D, Minimum Operational Performance Standards (MOPS) for Global Positioning System/Wide Area Augmentation System Airborne Equipment or an equivalent IFR certification standard;
- c) angular display generates lateral and vertical Flight Technical Errors (FTE) comparable to the ILS values;
- d) the lateral and vertical FTE are independent;
- e) the observed SBAS correlation coefficients are the same as the ILS correlation coefficients;
- f) in the case of continuity failure the reversion mode for APV and Category I procedures is the approach mode (LNAV);
- g) for APV and NPA procedures with a missed approach aligned within 3 degrees of the final approach course, coded as a TF segment, the system changes to LNAV final approach mode up to the turn initiation point of the first waypoint of the missed approach procedure; and
- h) the decision altitude/height (DA/DH) is read from a baro-altimeter.

Note.— The first waypoint of the missed approach is the waypoint after the landing threshold point (LTP).

2. SBAS APV OBSTACLE ASSESSMENT SURFACES

The criteria are based on two sets of obstacle assessment surfaces:

- a) final approach surfaces; and
- b) missed approach surfaces.

2.1 Final approach surfaces

2.1.1 Runway centre line surfaces

2.1.1.1 Along the runway centre line two surfaces are identified (W' and W). The W' surface is defined, close to the runway threshold, by applying a value, equal to the vertical full scale deflection, defined in DO-229D (paragraph 2, 2.4.4.4), plus the VAL, under the nominal GPA. Further from the threshold, the W' surface rises above the W surface, which then replaces it.

2.1.1.2 The way-point located at the FAP for navigation database coding purposes is not considered as a descent fix and the APV OAS extend into the intermediate segment.

2.1.2 Lateral surfaces

2.1.2.1 The X surface is derived from the X ILS surface which is lowered by a value equal to the difference between the VAL associated to the corresponding APV approach and 12 metres. This assumes that:

- a) the lateral and vertical FTE values are independent and are the same as ILS;
- b) the lateral NSE is the same as ILS;
- c) the core performance vertical NSE of the APV operation is not greater than the ILS; and
- d) SBAS APV NSE correlation coefficients are consistently small and of the same magnitude as observed ILS correlation coefficients.

2.1.2.2 As Annex 10 horizontal performance requirements for APV are equivalent to Category I ILS localizer performance requirements, the X surface is limited laterally by the line DD'' from the ILS/LOC.

2.2 Missed approach surfaces

2.2.1 Runway centre line surface

A missed approach surface, comparable to the ILS Z surface, is identified along the runway centre line. This surface should protect an aircraft flying above the vertical nominal path during the final approach segment, assuming the DA/H is read from a baro-altimeter. For this purpose it is necessary to move the origin of the APV Z surface away from the threshold by a distance greater than the 900 metre value of the ILS criteria. This 900 metre value is increased by the difference between the VAL associated to the corresponding APV approach and 12 metres divided by the tangent of the final glide path angle.

$$\frac{(VAL - 12)}{\tan GPA}$$

2.2.2 Lateral surfaces

2.2.2.1 When the initial missed approach segment is coded as a TF segment and aligned within 3° of the final approach course, the system maintains LNAV final approach mode until the first turning point. As a result, the final missed approach is protected by a corridor with an area semi-width of 1.76 km (0.95 NM) (Cat H 1.48 km (0.8 NM)).

2.2.2.2 The missed approach criteria accommodates:

- a) aircraft initiating a missed approach above the OCH; and
- b) continuity failure of the APV level of service during the final approach.

2.2.2.3 A linking surface, comparable to the ILS Y surface, is created between the final approach X surface and the missed approach Z surface. This Y surface, defined by the limit of the X surface, assumes a climb gradient of 2.5% and a splay of 20%. It is limited laterally by the 1.76 km (0.95 NM) (Cat H 1.48 km (0.8 NM)) area semi-width associated with the missed approach guidance.

2.2.2.4 SBAS Category I precision approach procedure obstacle clearance surfaces are discussed in Part III, Section 3, Chapter 5.

Note 1.— High quality track guidance throughout the final approach segment, coupled with continued lateral guidance throughout the straight missed approach justifies the use of a 20% splay for the Y surface. This splay does not have to be modified to ensure compatibility between categories of operation as for ILS (see Attachment to Part II).

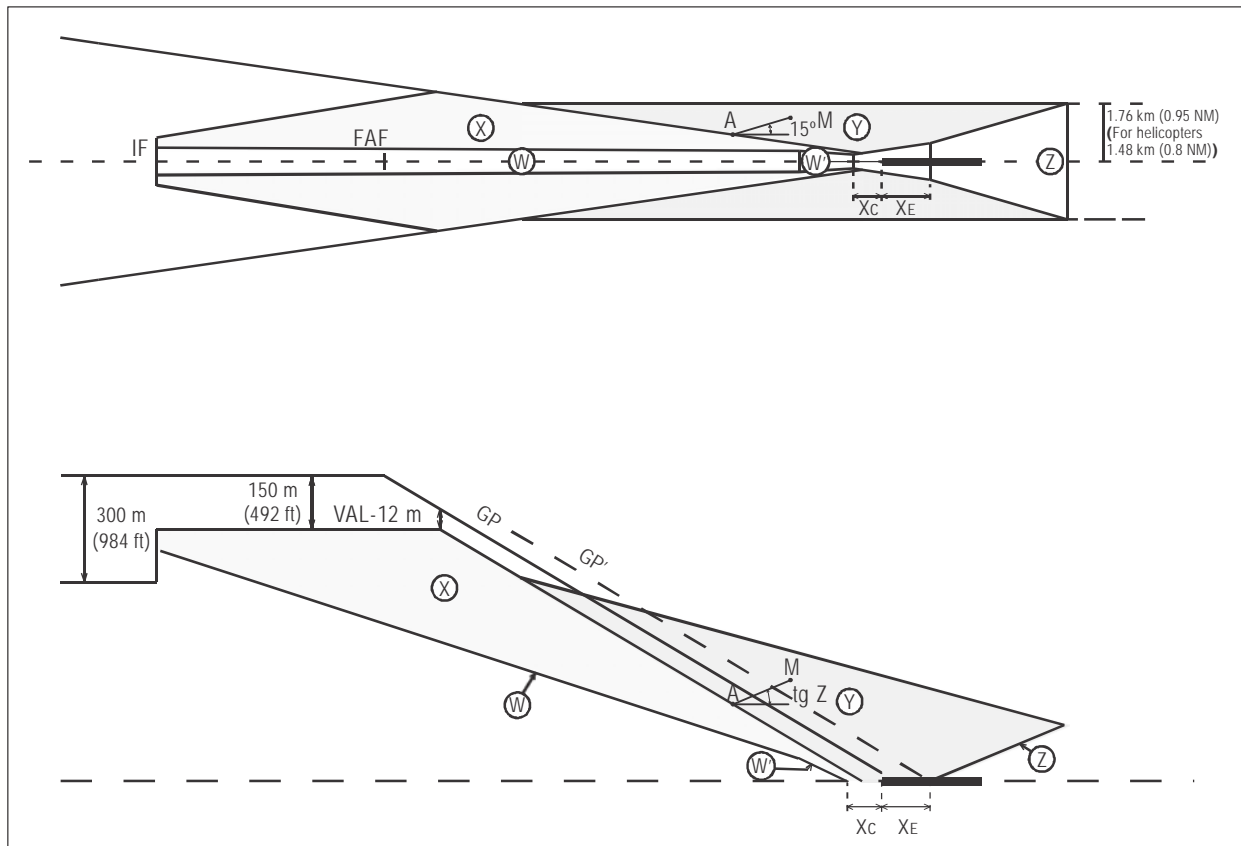

Figure III-Att-1. Illustration of SBAS APV obstacle assessment surfaces

**Procedures for
Air Navigation Services**

AIRCRAFT OPERATIONS

Part IV

HELICOPTERS

Chapter 1

PBN DEPARTURE PROCEDURES FOR HELICOPTERS USING GNSS OR SBAS RECEIVERS

1.1 GENERAL

1.1.1 Application

1.1.1.1 This chapter describes the criteria for PBN (RNAV and RNP) departure procedures specific to helicopter operations and includes criteria for the design of departure procedures from both instrument heliports or runways and heliports, or landing locations. Criteria for departures from heliports and landing locations are accommodated with point-in-space (PinS) departure procedures.

1.1.1.2 The general criteria of Part I, Section 3 and Part III, Sections 1, 2 and 3 as amplified or modified by the criteria in this chapter apply to RNAV and RNP departure procedures for helicopters.

1.2 HELICOPTER DEPARTURES FROM INSTRUMENT HELIPORTS OR RUNWAYS

(To be developed)

1.3 HELICOPTER POINT-IN-SPACE (PINS) DEPARTURES FROM HELIPORTS OR LANDING LOCATIONS

1.3.1 PinS departure — General

1.3.1.1 *Description.* The PinS departure procedure consists of a visual segment followed by an instrument segment. The visual segment of the departure starts from the heliport or landing location and ends at the initial departure fix (IDF) at or above the IDF minimum crossing altitude (MCA). PinS departure procedures are constructed up to the IDF by applying the visual segment criteria, defined in this chapter, and beyond the IDF by applying the applicable PBN criteria, defined in Part III, Section I, Chapter 2. If the criteria for the visual segment can be met, the PinS departure procedure is annotated with the instruction “proceed visually”. If the criteria for the visual segment cannot be met, the procedure is annotated with the instruction “proceed VFR”. In the latter case there is no obstacle protection in the visual segment. The obstacle protection after the IDF is the same as for a PinS departure with a proceed visually instruction.

Note 1.— The term “proceed VFR”, implies that the pilot can comply with VFR in the visual segment to see and avoid obstacles and can cross the IDF at or above the MCA.

Note 2.— The term “proceed visually” implies that pilots can navigate by visual reference and see and avoid obstacles, with visibility sufficient to return to the heliport if they cannot continue visually to cross the IDF at or above the IDF MCA. Visual flight may be conducted below minima required for VFR.

1.3.1.2 The proceed visually segment can be a direct visual segment (visual segment flown directly from the heliport or landing location to the IDF) or a manoeuvring visual segment (initial take-off in a direction other than directly to the IDF).

1.3.2 PinS departure — Instrument phase — Description and protection

1.3.2.1 *Application of PBN criteria.* For the construction of the instrument segment of the departure procedure, the appropriate helicopter navigation specifications identified in Part III, Section I, Chapter 2, shall be used. The navigation information is also used during the visual segment to aid in the identification of the IDF and, hence, only GNSS sensors may be used on these procedures.

1.3.2.1.1 *IDF fix tolerance.* The ATT, XTT and area semi-width values at the IDF are detailed in Part III, Section 1, Chapter 2.

1.3.2.1.2 Transition from visual segment to instrument segment of the PinS departure occurs at the IDF and requires the blending of the visual segment criteria with the applicable PBN protection areas at the IDF.

1.3.2.2 *Instrument segment of the PinS departure procedure.* The instrument segment consists of one or more legs and continues until the minimum en-route altitude is reached.

1.3.2.2.1 *Procedure design gradient (PDG).* The standard PDG is 5.0 per cent. It originates from the IDF MCA.

1.3.2.2.2 *Multiple PDGs.* Where multiple PDGs exist for a PinS departure, subsequent gradients in the departure shall be equal to or less than the PDG for the preceding segment.

1.3.2.2.3 *Minimum obstacle clearance (MOC).* Between the earliest IDF and the IDF, the MOC is equal to 30 m (100 ft). Between the IDF and the latest IDF, the MOC is increased by a value corresponding to the PDG, and subsequently from the latest IDF is increased by 0.8 per cent of the distance from the latest IDF until the en-route MOC (300 m (1 000 ft), 600 m (2 000 ft) mountainous area) is reached. An alternative to increasing the PDG above the 5 per cent standard value beyond the IDF, would be to increase the IDF MCA to provide the necessary clearance over an obstacle in the subsequent departure leg while maintaining a lower PDG.

1.3.2.2.4 *IFR OIS dimensions.* The OIS dimensions shall be as follows:

- a) *Origin.* The IFR OIS originates at the earliest IDF.
- b) *Area semi-widths for PinS departures (instrument segment).* See Part III, Section 1, Chapter 2.
- c) *IFR OIS vertical dimension.* The OIS is level at the IDF MCA minus MOC from the earliest IDF until the latest IDF. It then has a gradient of (PDG minus 0.8 per cent).

1.3.3 PinS departure with a “proceed visually” instruction – Direct visual segment

1.3.3.1 *Track change at the IDF.* The maximum track change at the IDF is 30°.

1.3.3.2 *Visual segment design gradient (VSDG).* The VSDG is the designed climb gradient. In the direct visual segment it is established by connecting the edge of the heliport or landing location safety area to the IDF at the IDF MCA. The VSDG shall not be less than 5 per cent. It may exceed 5 per cent when necessary to mitigate penetration of the visual or IFR obstacle identification surfaces (OIS) (see paragraph 1.3.3.8).

1.3.3.3 *Initial departure fix (IDF)*. The IDF shall be located:

- a) to provide sufficient visual reference from the heliport or landing location to the IDF to enable the helicopter to cross the IDF at or above the MCA; and
- b) to cater to the minimum starting height of the subsequent instrument segment.

1.3.3.4 *Visual segment length*. The length of the visual segment shall be measured from the outer edge of the heliport or landing location safety area to the IDF. The minimum length of the visual segment shall be 1 482 m (0.8 NM).

1.3.3.5 The visual OIS (see paragraph 1.3.3.6) terminates within the lateral boundaries of the instrument segment protection area. If the RNAV-1/RNP1 navigation specification is used for the instrument segment of flight, this results in a maximum visual segment length as follows:

- a) for no track change at the IDF, the maximum visual segment length is 13.9 km (7.5 NM);
- b) for $0^\circ < \text{track change} \leq 10^\circ$, the maximum visual segment length is 11.9 km (6.4 NM);
- c) for $10^\circ < \text{track change} \leq 20^\circ$, the maximum visual segment length is 9.3 km (5.0 NM);
- d) for $20^\circ < \text{track change} \leq 30^\circ$, the maximum visual segment length is 6.5 km (3.5 NM).

1.3.3.6 *Visual segment obstacle identification surface (OIS)*. The visual segment is protected by a Visual OIS. The dimensions of the Visual OIS are as follows:

- a) *Alignment*. The Visual OIS is constructed symmetrically around the direct track from the heliport/landing location to the IDF.
- b) *Origin*. The origin is perpendicular to the direct VS track at the boundary of the heliport or landing location safety area.
- c) *Width*. The area semi-width at the origin is 45 m (150 ft) and the area splays at 15° until the area connects with the instrument segment protection (see paragraph 1.3.3.7).
- d) *Slope*. The Visual OIS originates at the elevation of the heliport/landing location and rises to the IDF MCA minus 30 m (100 ft).

1.3.3.7 *Blending of visual segment with PBN criteria at the IDF*. Figure IV-1-1 depicts the vertical blending of the Visual OIS with an RNP-1/RNAV-1 OIS at the IDF. Figure IV-1-2 depicts the lateral blending of surfaces at the IDF (with track change at the IDF). The Visual OIS lateral splay is initially less than the instrument primary area semi-width. A portion of the instrument primary and secondary areas are subtended by the Visual OIS and need not be considered for obstacle assessment purposes because the visual segment is using a dead reckoning splay.

1.3.3.8 *Visual segment OIS penetration*. The Visual OIS shall be evaluated and any penetrating obstacles should be lit and marked if feasible. If operationally feasible, the VSDG should be increased to clear the critical visual segment obstacle. The minimum VSDG to clear the obstacle can be calculated by using an “adjusted” OIS. The “adjusted” OIS clears the obstacle, levels at the MCA minus 30 m (100 ft) and continues level until the origin of the IFR OIS at the earliest IDF. The minimum VSDG to clear the obstacle is then established by connecting its origin to the IDF MCA at the same along-track location as where the OIS becomes level (see Figure IV-1-3).

1.3.3.9 *Mitigation of obstacle penetration in the instrument segment.* To avoid obstacle penetration of the IFR OIS, the IDF MCA should be increased such that the IFR OIS remains clear, or a turn initiated, in preference to increasing the PDG above the standard 5 per cent. The resulting VSDG is increased and is determined by the elevation change between the boundary of the heliport or landing location safety area and the revised IDF MCA (see Figure IV-1-4).

1.3.4 PinS departure with a “proceed visually” instruction — Manoeuvring visual segment

1.3.4.1 *Manoeuvring VS protection.* A manoeuvring visual segment is protected for the following manoeuvre: the pilot takes off in a direction other than directly to the IDF and then visually manoeuvres to join the initial instrument segment at the IDF.

1.3.4.2 This manoeuvring VS is protected by one sloping initial Visual OCS and one Visual OIS.

Note.— The protection provided for this VS is comparable with the one provided for PinS approaches followed by a manoeuvring VS (see Chapter 2, paragraph 2.9.3).

1.3.4.3 *IDF minimum crossing height.* (MCH is the actual height of MCA above the heliport/landing location). The MCH of the IDF for a PinS departure procedure with a manoeuvring visual segment shall not be less than 90 m (295 ft) above the heliport/landing location elevation.

1.3.4.4 *Sloping initial visual OCS*

1.3.4.4.1 The sloping initial visual OCS is aligned symmetrically on the centre line of the take-off climb surface.

Note.— If more than one take-off climb surface has to be considered, a Visual OCS is designed for each.

1.3.4.4.2 The sloping initial visual OCS originates at the outer edge of the heliport or landing location safety area (SA).

1.3.4.4.3 The width of the sloping initial visual OCS at its origin is equal to the width of the SA.

1.3.4.4.4 The outer edges splay from their origins at the edge of the SA, symmetrically around the centre line of the take-off climb surface, to an overall maximum width of 120 m, at which point the outer edges parallel the centreline. For the provision of day-only operations, the splay is 10 per cent. For night operations, the splay angle is increased to 15 per cent.

1.3.4.4.5 The elevation of the origin of the sloping initial visual OCS is equal to the heliport or landing location elevation.

1.3.4.4.6 The sloping initial visual OCS inclines at nominally 12.5 per cent from the heliport/landing location elevation to the point where the surface reaches the height of 152 m (500 ft) above heliport/landing location elevation.

1.3.4.5 *Visual OIS*

1.3.4.5.1 The visual OIS provides awareness in the area (called “manoeuvring area”) where the pilot is expected to manoeuvre visually from the initial departure track to join the initial instrument segment at the IDF.

1.3.4.5.2 Description of the “manoeuvring area”

1.3.4.5.2.1 The manoeuvring area is defined based on the following rules:

- a) the pilot initially climbs on the centre line of the take-off climb surface to reach the greater of the two following heights before manoeuvring toward the IDF:
 - 1) IDF MCH/2; and
 - 2) 90 m (295 ft) above the heliport/landing location elevation;
- b) the pilot continues to climb and accelerates so as to cross the IDF at or above the IDF MCA.

1.3.4.5.2.2 The outer boundaries of the manoeuvring area are based on the following assumed worst-case trajectories (see Figure IV-1-5):

- a) *first trajectory*: the pilot climbs in accordance with paragraph 1.3.4.5.2.1 a) above and then turns right to join the IDF;
- b) *second trajectory*: the pilot climbs in accordance with paragraph 1.3.4.5.2.1 a) above and then turns left to join the IDF.

1.3.4.5.2.3 The “manoeuvring area” is the area representing all the lines that originate at the IDF and connect with a “turn area” aligned symmetrically around the centre line of the take-off climb surface.

Note.— If more than one take-off climb surface has to be considered, the final “manoeuvring area” is the addition of all “manoeuvring areas” obtained.

1.3.4.5.2.4 Description of the “turn area” (see Table IV-1-1 and Figure IV-1-6)

1.3.4.5.2.4.1 The “turn area” is defined by an angle α each side of the centre line of the take-off climb surface (in order to consider a right turn and a left turn) and by a radius r .

Note.— The “manoeuvring area” can be reduced in size if a prominent obstacle is located near the heliport/landing location. In that case, after the initial climb, one turn direction to join the IDF is prohibited. Consequently, the “turn area” is defined only on one side of the centre line of the take-off climb surface (see Figure IV-1-9).

1.3.4.5.2.4.2 Radius (r) of the “turn area”:

- a) if the IDF MCH is equal to or less than 183 m (600 ft) above the heliport/landing location elevation, r is constant and equal to 1 482 m (0.8 NM);
- b) if the IDF MCH of the procedure is more than 183 m (600 ft) above the heliport/landing location elevation, r increases linearly (185 m (0.1 NM) for each additional 30 m (100 ft) above 183 m (600 ft)).

1.3.4.5.2.4.3 Angle (α) of the “turn area”:

- a) if the IDF MCH of the procedure is equal to or less than 183 m (600 ft) above the heliport/landing location elevation, α is constant and equal to 50°;

- b) if the IDF MCH of the procedure is more than 183 m (600 ft) above the heliport/landing location elevation and equal to or less than 304 m (1 000 ft) above the heliport/landing location elevation, α decreases linearly (5° for each additional 30 m (100 ft) above 183 m (600 ft));
- c) if the IDF MCH of the procedure is more than 304 m (1 000 ft) above the heliport/landing location elevation, α is constant and equal to 30° .

Note.— Where operationally beneficial, in order to extend the resulting “manoeuvring area”, the “turn area” can be extended by using wider angles on one side or on both sides of the centre line of the take-off climb surface.

Table IV-1-1. Definition of the “turn area” for a set of IDF MCH values

- a) Units in metres for the IDF MCH and r:

IDF MCH	93 m*	123 m*	153 m*	183 m*	213 m*	243 m*	273 m*	304 m*
r	1 482 m	1 482 m	1 482 m	1 482 m	1 667 m	1 852 m	2 037 m	2 222 m
α	50°	50°	50°	50°	45°	40°	35°	30°

* Height above the heliport/landing location elevation.

- b) Units in ft for the IDF MCH and in NM for r:

IDF MCH	300 ft*	400 ft*	500 ft*	600 ft*	700 ft*	800 ft*	900 ft*	1 000 ft*
r	0.8 NM	0.8 NM	0.8 NM	0.8 NM	0.9 NM	1 NM	1.1 NM	1.2 NM
α	50°	50°	50°	50°	45°	40°	35°	30°

* Height above the heliport/landing location elevation.

Note.— Taking into account the buffer of 741 m (0.4 NM) that will be applied to these values to define the OIS (see paragraph 1.3.4.5.3.2), these values are acceptable for all the operational scenarios regarding the temperature and the heliport or landing location elevation.

1.3.4.5.3 OIS definition

1.3.4.5.3.1 The OIS surface is defined by the “manoeuvring area” with an additional buffer equal to 741 m (0.4 NM) (see Figure IV-1-7).

Note.— If the initial take-off can be performed in an omni-directional fashion, the OIS is a surface aligned symmetrically on the course between the HRP and the IDF and that connects tangentially with the following: a circle centred on the IDF, having a radius equal to 741 m (0.4 NM), and a circle centred on the HRP, having a radius equal to (r + additional buffer value) (see Figure IV-1-8).

1.3.4.5.3.2 The OIS identifies obstacles in the “manoeuvring area” that are at or above 150 ft below the minimum height to which the pilot will initially climb before manoeuvring toward the IDF. Based on the above assumptions, the OIS is a surface surrounding the “manoeuvring area” and defined at the greater of the following heights:

- a) IDF MCH/2 – 46 m (150 ft); and

b) 46 m (150 ft) above the heliport/landing location elevation.

1.3.4.5.3.3 Obstacles that penetrate the OIS shall be charted, and may be marked and/or lighted when feasible.

1.3.4.6 *Maximum speed restrictions.* There are no maximum speed restrictions when operating on a manoeuvring visual segment.

1.3.4.7 *Manoeuvring visual segment length.* The minimum distance from HRP to IDF is 0.8 NM.

1.3.4.8 *Track change at the IDF.* The track change at the IDF shall be less than 30° for all the possible visual trajectories. Consequently, the angle between the initial instrument segment direction after the IDF and the direction of the “extreme” visual trajectories corresponding to the limits of the “manoeuvring area” shall be less than 30° (see Figures IV-1-7 and IV-1-8).

1.3.5 PinS departure with a “proceed VFR” instruction — visual segment

1.3.5.1 Where “proceed visually” instruction is not suitable or possible, a PinS departure procedure with a “proceed VFR” instruction shall be designed.

1.3.5.2 There is no obstacle protection in the visual segment. The pilot complies with VFR to see and avoid obstacles when proceeding from the heliport or landing location to the IDF, to cross at or above the IDF MCA.

1.4 PROMULGATION

1.4.1 *Procedure identification.* PinS departures shall be titled “RNAV XXXXX DEPARTURE”, where XXXXX is the name of the last waypoint in the departure procedure. The plan view shall include a note that the procedure is Cat H only.

1.4.2 The IDF shall generally be charted as a “fly-by” waypoint. If for operational reasons, the IDF needs to be a “fly-over” waypoint, it should be charted as a “fly-over” waypoint.

1.4.3 *Departure climb table.* A departure climb table shall be provided in the profile view with the visual segment design gradient (VSDG) for Direct-VS and procedure design gradient (PDG) in m/km (ft/NM) for each instrument segment. Additional information shall include the MCA for the end waypoint for each segment. If a segment exceeds the PDG or VSDG standard of 5 per cent, the segment gradient shall also be charted in per cent, to the nearest one-tenth of a per cent, in the departure climb table. A PDG greater than 5 per cent shall also be annotated on the chart. Where multiple PDGs exist for a PinS departure, e.g. due to multiple obstacle clearance requirements and/or air traffic control requirements, or to meet en-route minimum crossing altitude requirements, the highest computed climb gradient for that segment shall be published.

1.4.4 *Charting of the MCA.* MCAs for all waypoints in the procedure shall be charted. On the profile view the MCA of each departure waypoint shall be charted as “YYYY” where “YYYY” is the MCA in metres (feet). MCA information shall also be included on the plan view. The MCA shall be charted adjacent to the waypoint to which it applies.

1.4.5 *Segment tracks and lengths.* Segment tracks and lengths shall be charted.

1.4.6 *Obstacles.* Obstacles penetrating the visual OIS shall be charted.

1.4.7 *Additional information for the manoeuvring-VS*

1.4.7.1 The centre line(s) and direction(s) of the take-off climb surface(s) taken into account for the protection of the manoeuvring visual segment shall be indicated on the chart.

1.4.7.2 The “manoeuvring area” shall be represented on the chart either in an inset on the plan view, or on a continuation sheet or the verso of the chart. Information depicted in the inset shall be charted to scale. If the manoeuvring area is not depicted in an inset, the plan view shall contain an annotation directing the pilot to the continuation sheet or the verso of the chart.

1.4.7.3 If the “manoeuvring area” is reduced in size in order to take into account a significant obstacle, restricted use airspace or environmentally sensitive areas located near the heliport/landing location, the following elements shall be indicated on the chart:

- a) the boundaries of the manoeuvring area;
- b) the location of the significant obstacle/restricted use airspace/environmentally sensitive area; and
- c) the boundaries of any ‘no manoeuvring’ area annotated ‘No manoeuvring’.

1.4.7.4 The departure shall be annotated “Proceed visually to the IDF” or “Proceed VFR to the IDF” as appropriate.

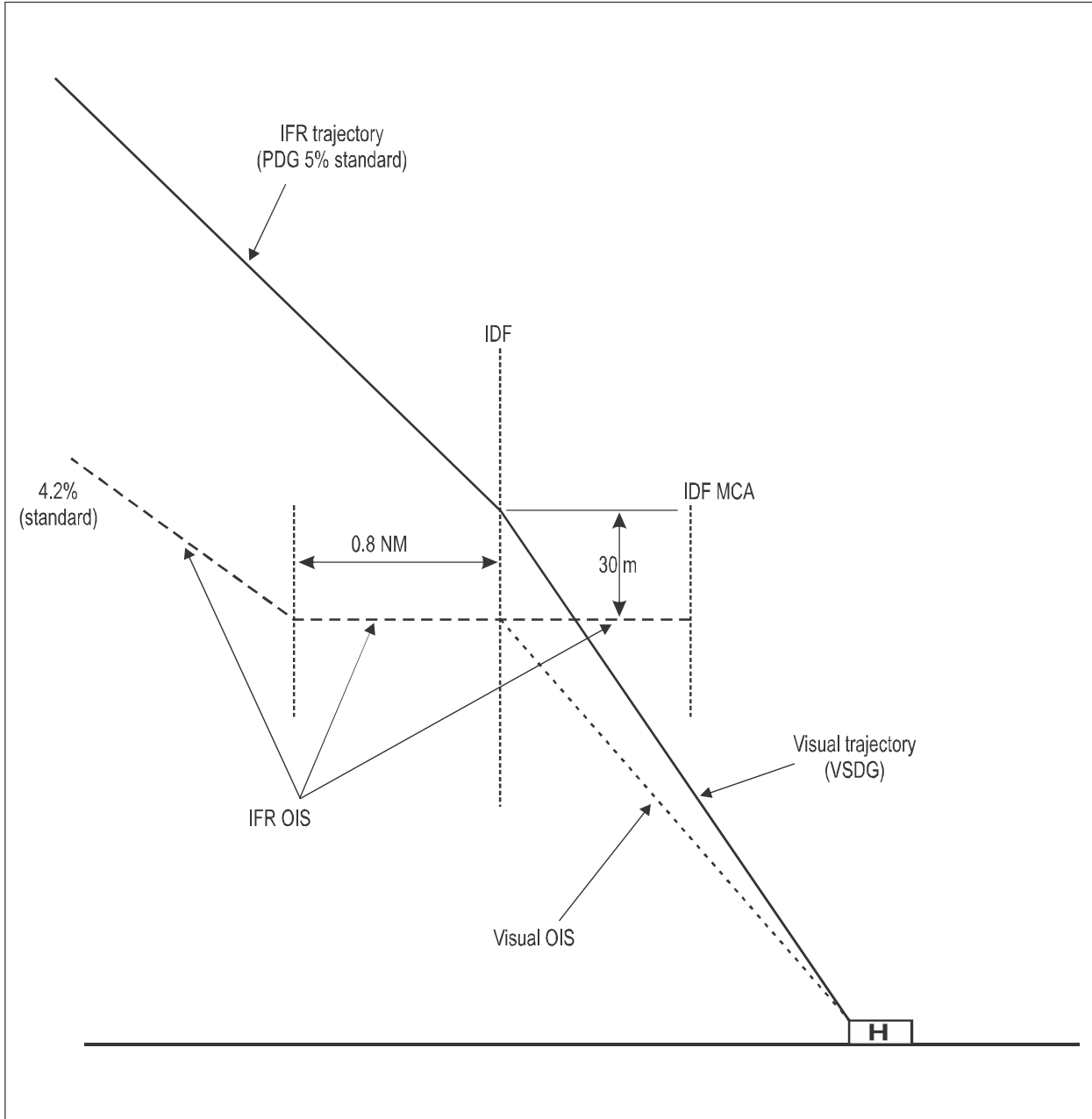

Figure IV-1-1. Vertical blending of visual segment OIS and IFR

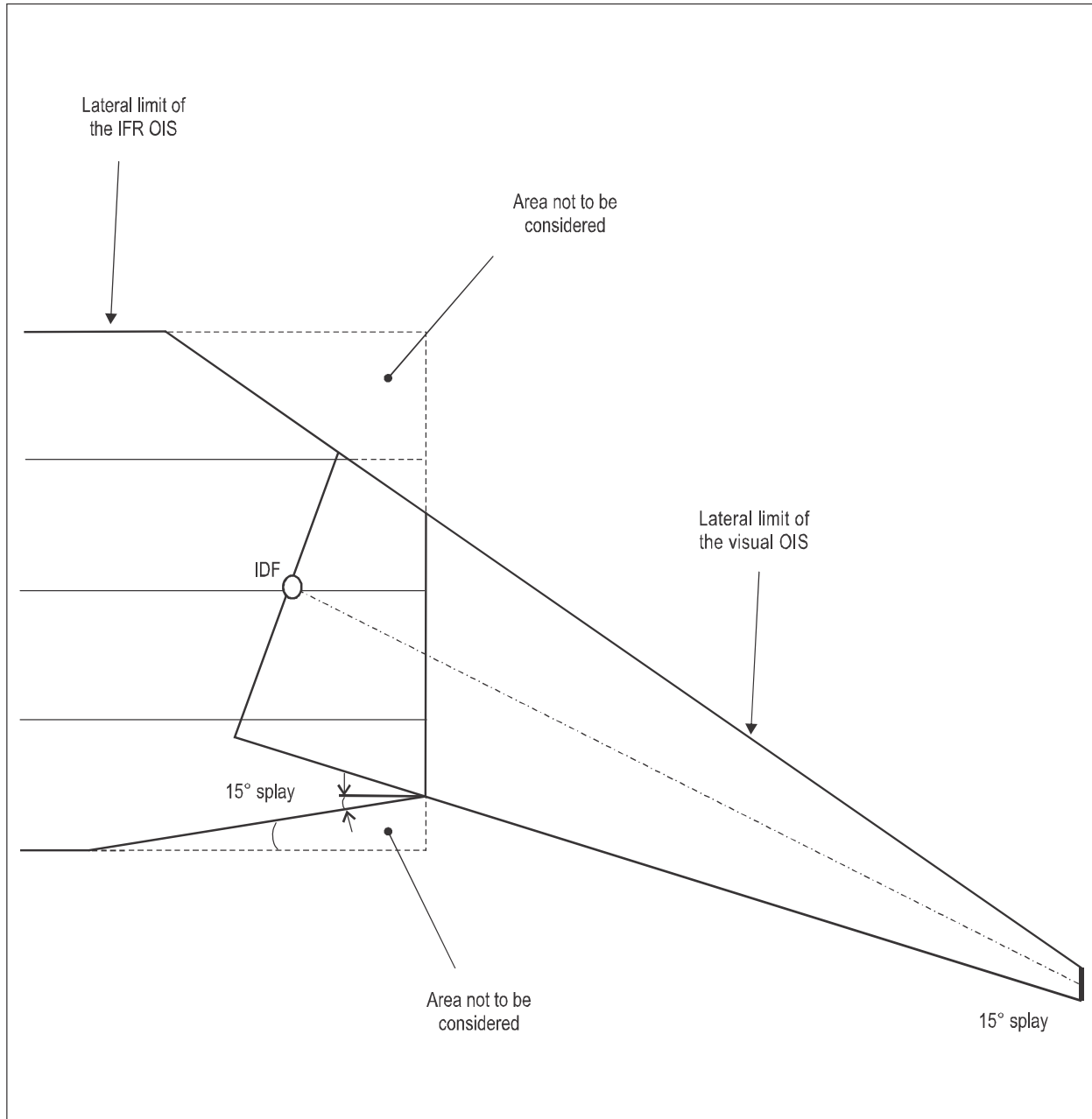

Figure IV-1-2. Lateral blending with track change at IDF

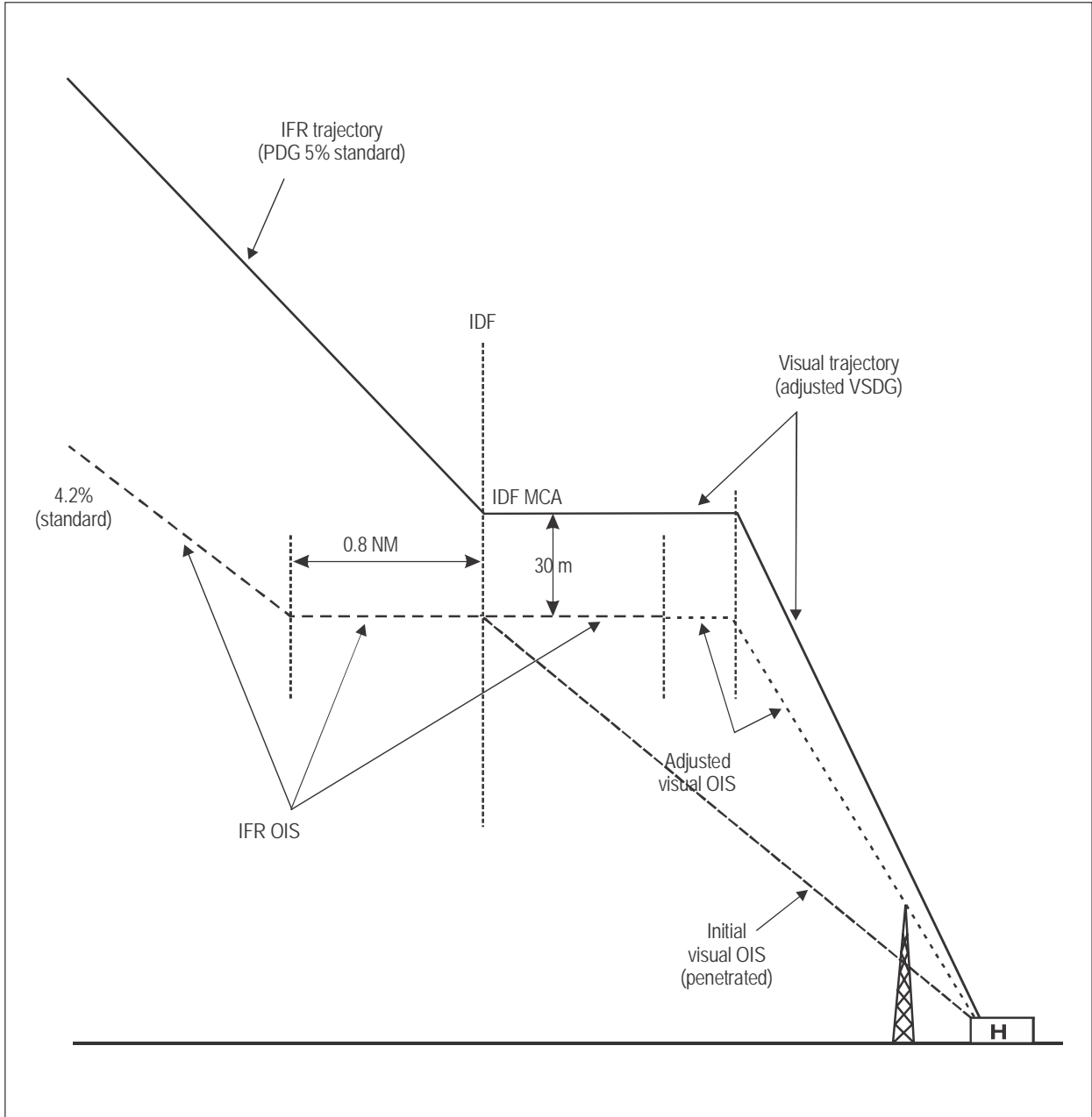

Figure IV-1.3. Mitigation of OIS penetration by raising the VSDG

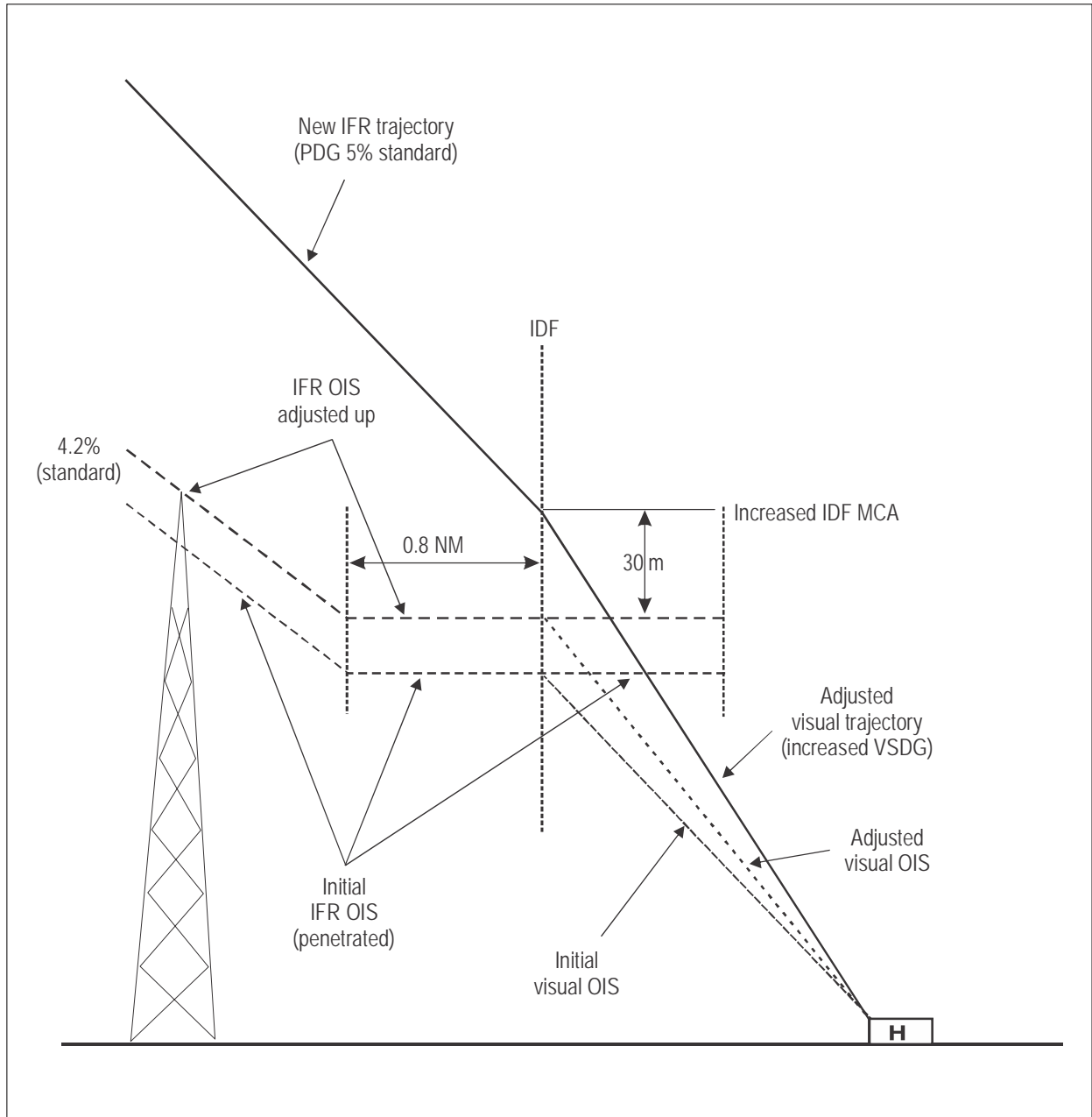

Figure IV-1-4. Mitigation of obstacle penetration in the instrument segment by increasing the IDF MCA

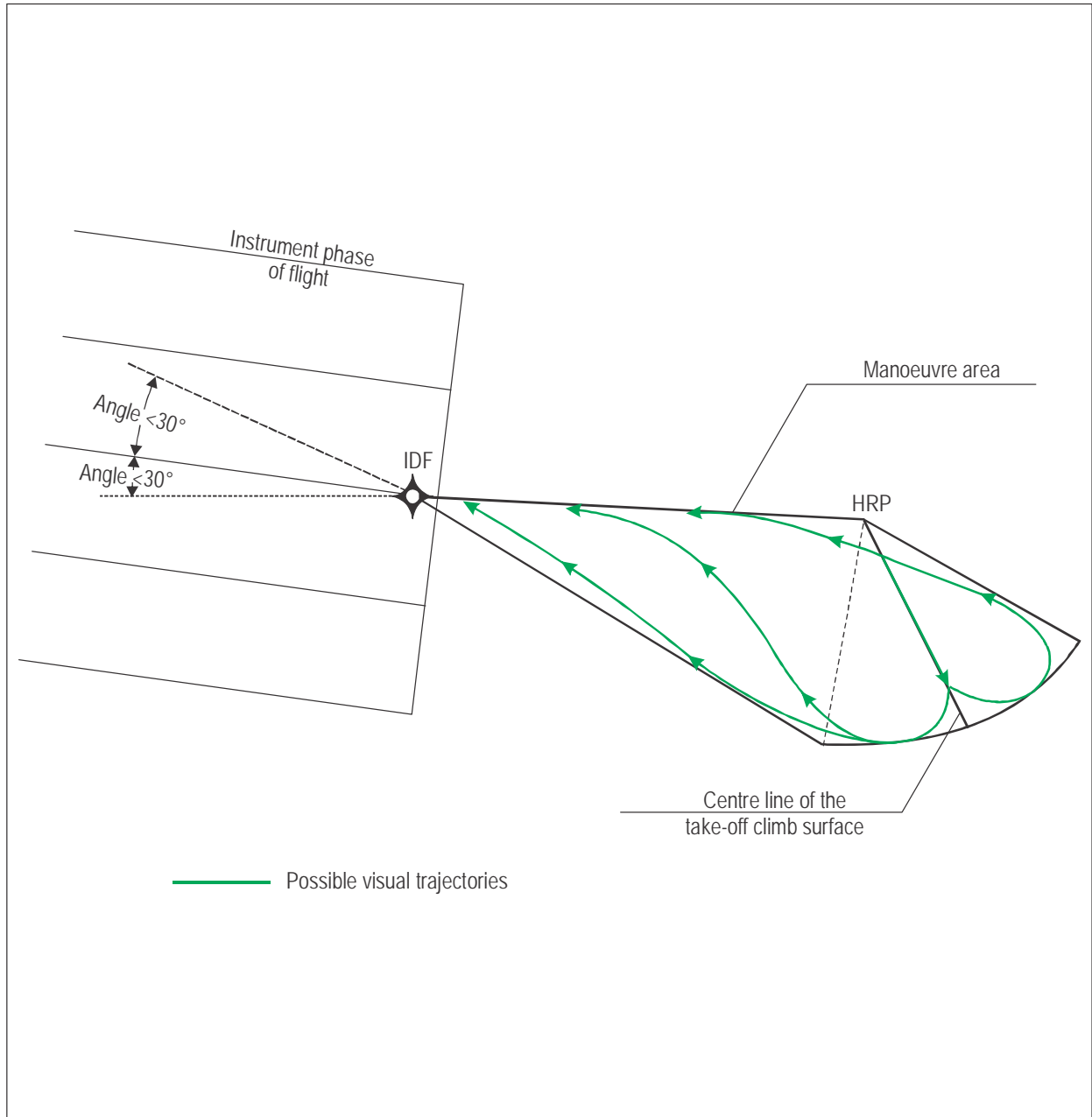

Figure IV-1-5. Manoeuvring visual segment representation of the possible trajectories defining the “manoeuvring area” for a defined centre line of the take-off climb surface

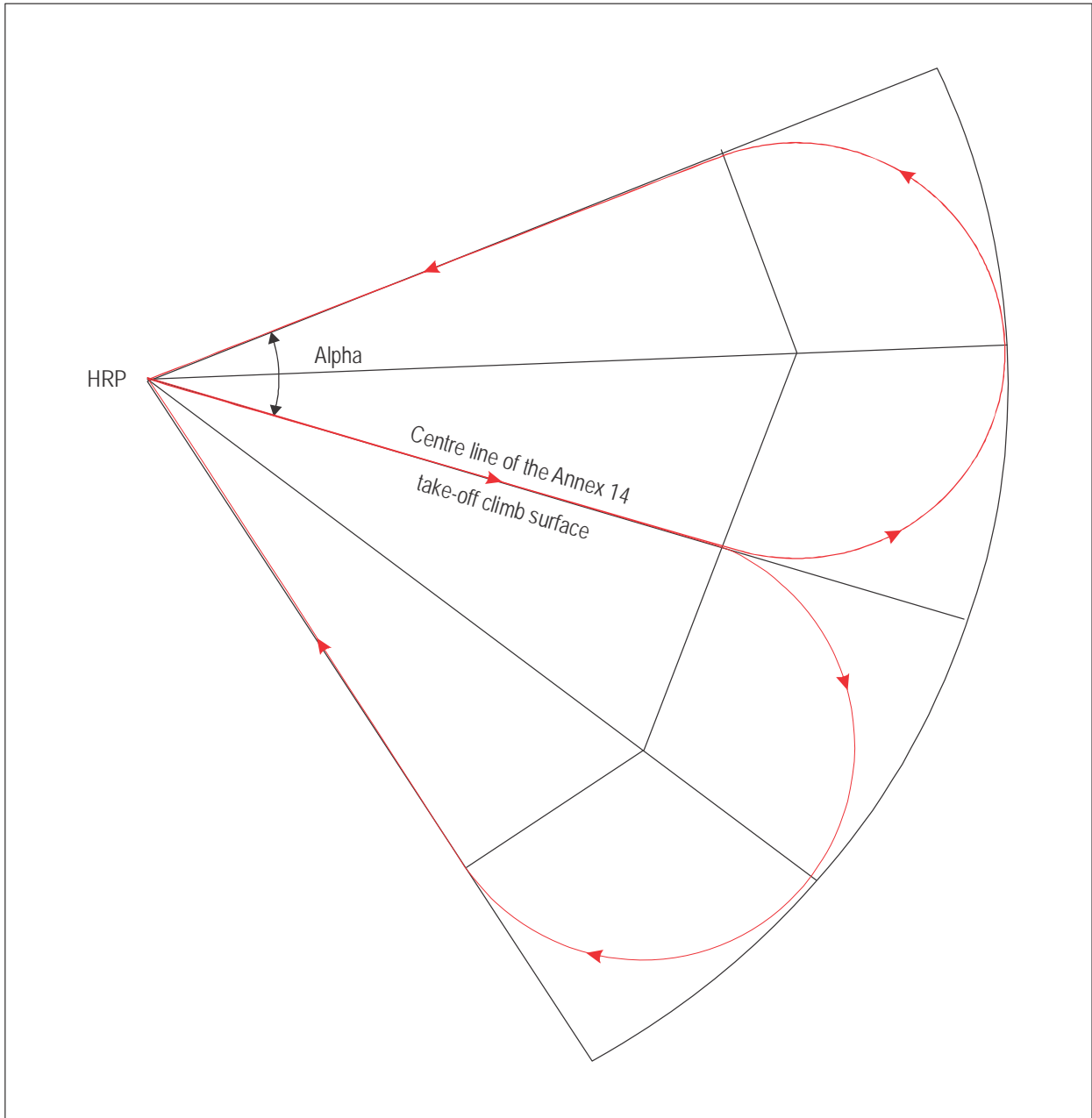

Figure IV-1-6. Manoeuvring visual segment description of the "turn area"

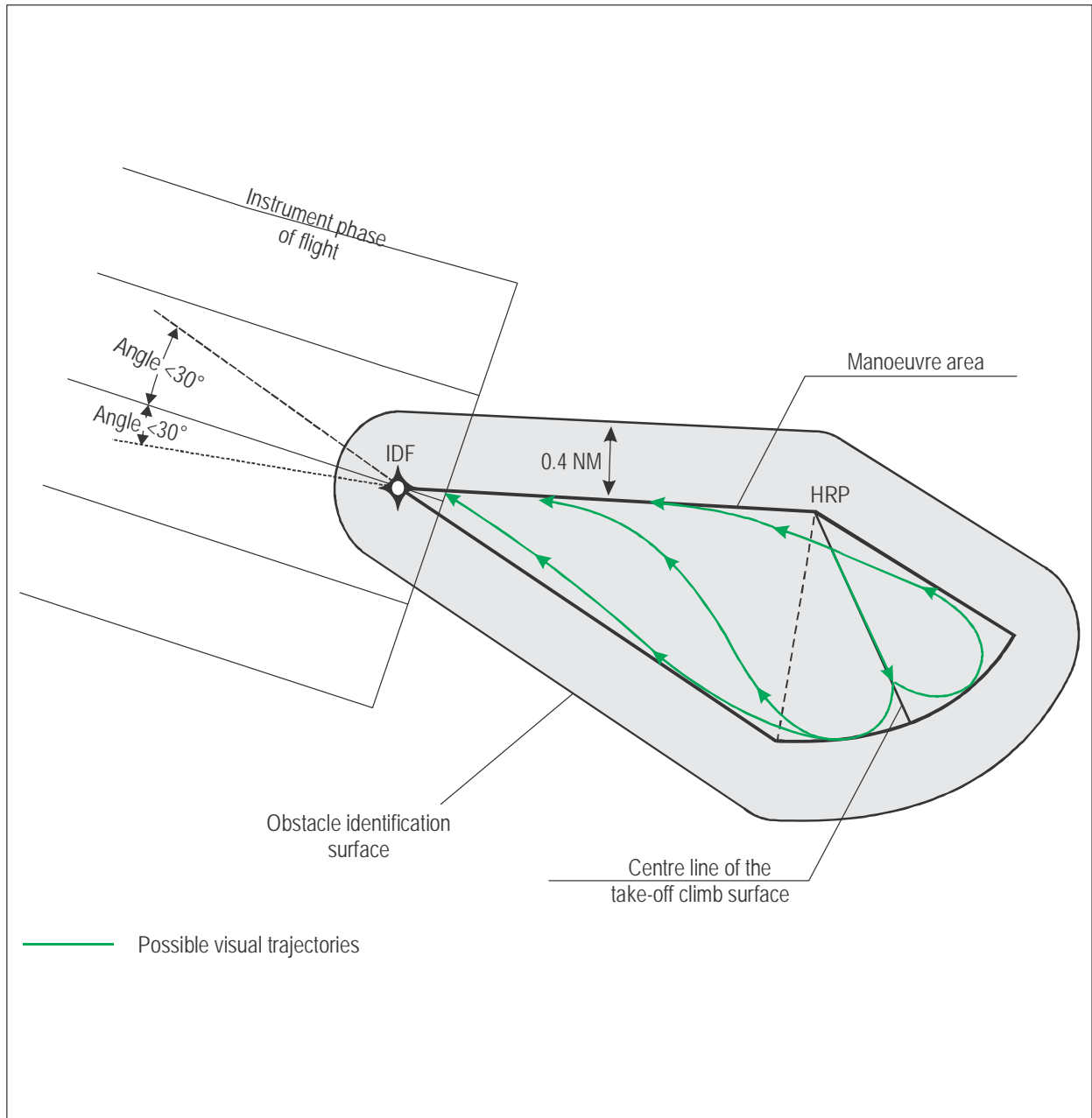

Figure IV-1-7. Manoeuvring visual segment representation of the level OIS for a defined centre line of the take-off climb surface

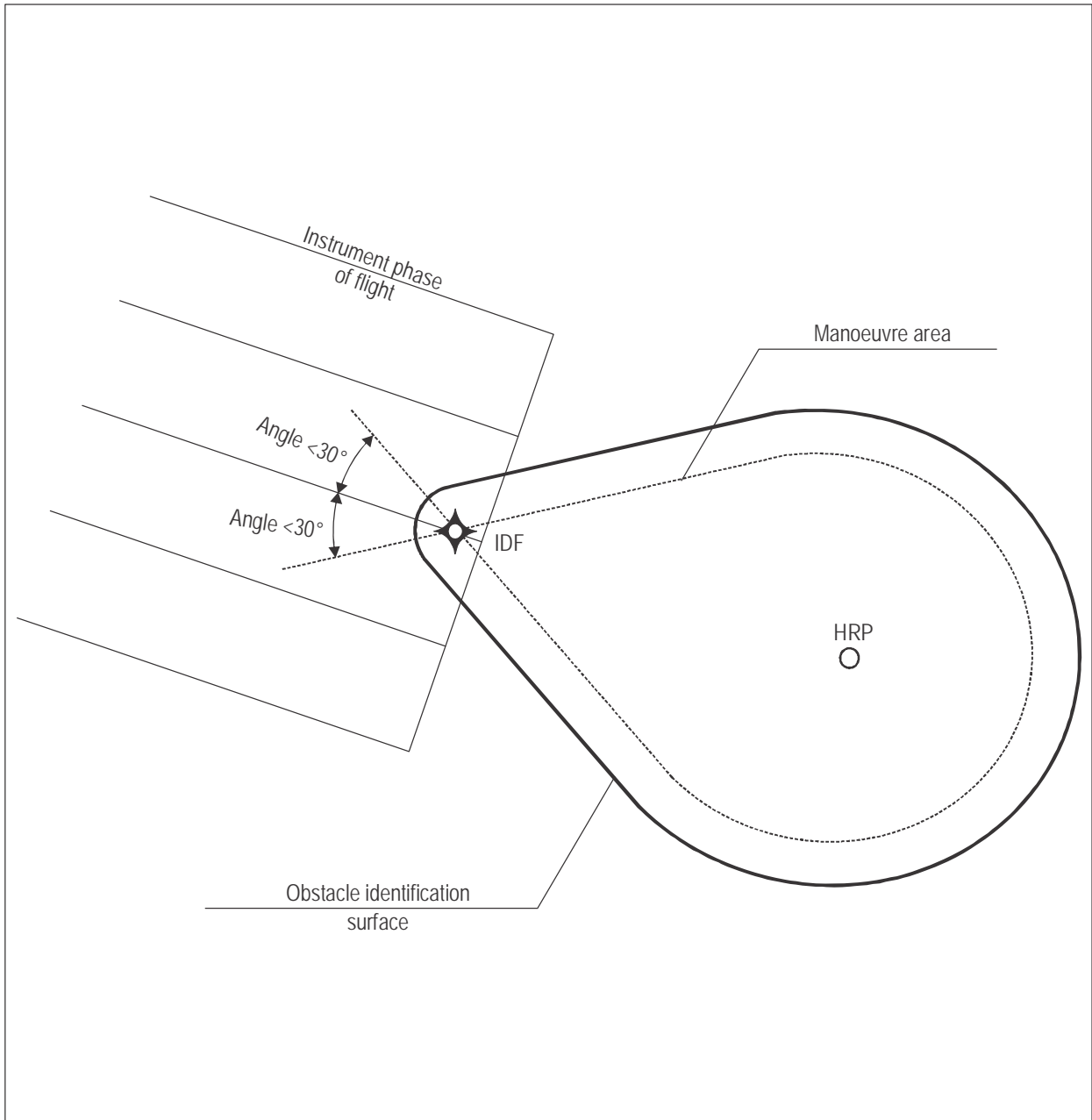

Figure IV-1-8. Manoeuvring visual segment representation of the level OIS if the initial take-off can be performed in an omni-directional way

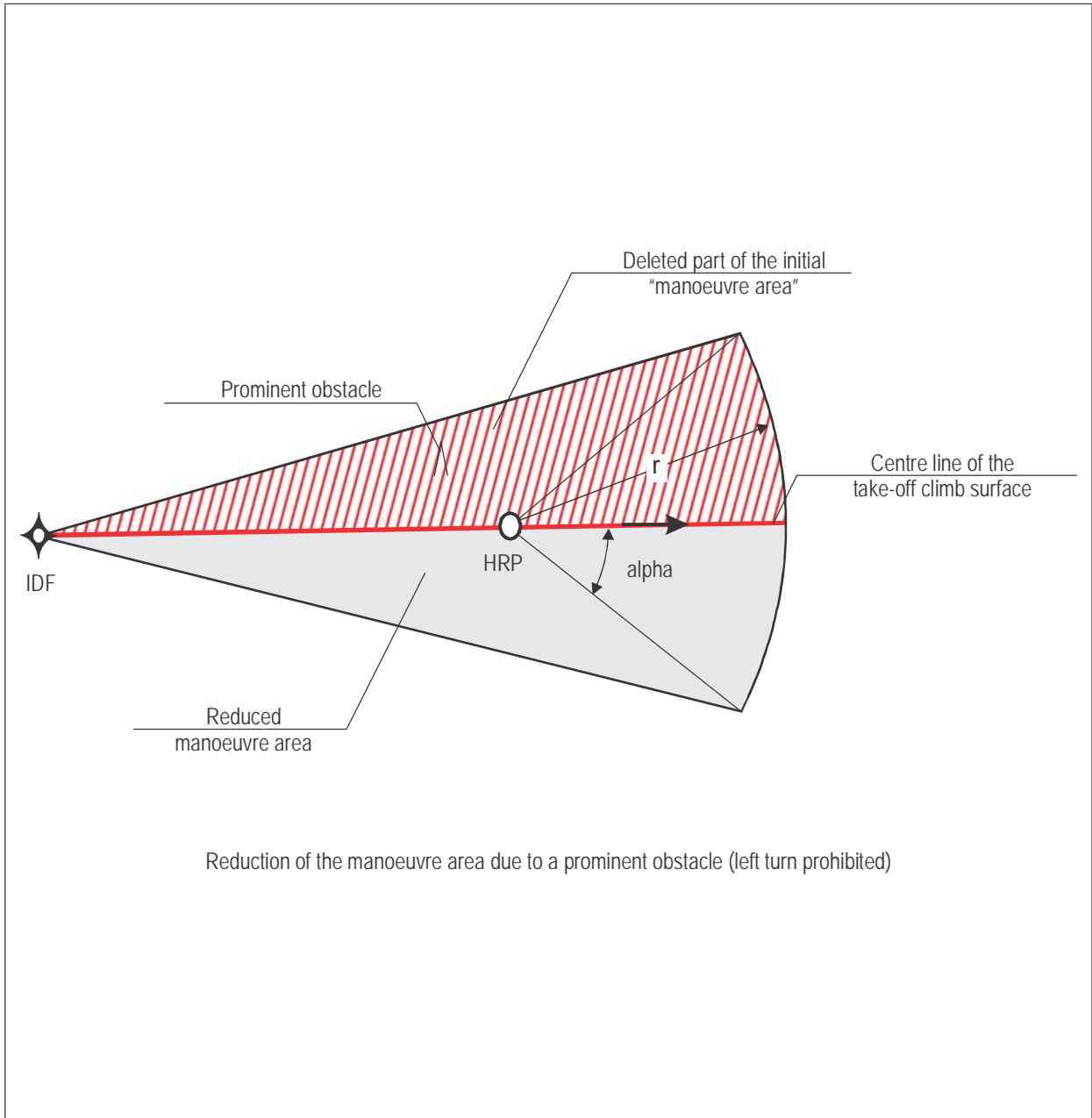

Figure IV-1-9. Manoeuvring visual segment reduction of the “manoeuvring area” due to a prominent obstacle

Chapter 2

POINT-IN-SPACE (PinS) RNP APCH APPROACH PROCEDURES FOR HELICOPTERS DOWN TO LNAV MINIMA

2.1 GENERAL

2.1.1 The general criteria in Part I, Section 4, as well as Part III, Section 2, Chapter 2, as amplified or modified by the criteria in this chapter apply to area navigation (RNAV) approach procedures for GNSS receivers. These specified instrument procedures may be developed for the use of helicopters. It is intended that these specified procedures be designed using the same conventional techniques and practices for aeroplane categories as those explained elsewhere in this document.

2.1.2 *Helicopter specific parameters.* Parameters such as airspeed, descent and climb gradients are specified in this chapter for exclusive use in designing helicopter procedures. Fix tolerances and area widths are specified in Part III, Section 1, Chapter 2, "GNSS RNAV". These specifications have been defined in accordance with the helicopter performance characteristics and the operational requirements to perform the procedure.

2.1.3 *Approach speeds.* When the helicopter reaches the obstacle clearance altitude/height (OCA/H), it must have a sufficient distance to decelerate and transition to flight by visual reference. The greater the approach speed on final, the larger the required deceleration distance. Criteria are provided in this chapter to accommodate helicopters flying the final and missed approach segments at speeds not to exceed 90 KIAS and for those flying the final and missed approach segments at speeds not to exceed 70 KIAS. The missed approach airspeed limitation applies until the helicopter is established on the inbound course to the missed approach holding waypoint or clearance limit.

2.1.4 *Secondary areas.* The general criteria for secondary areas apply as modified or amplified in this chapter.

2.1.5 *Certification/operational approval.* The aircraft equipped with a GNSS receiver as described in Part III, Section 1, Chapter 2, that have been approved by the national authority for the operator for RNP APCH operations may use these systems to carry out approaches.

2.2 GNSS RNAV SYSTEM ACCURACY

The criteria in Part III, Section 1, Chapter 2, apply as modified or amplified in this chapter.

2.3 ARRIVAL ROUTES

2.3.1 The provisions of Part III, Section 3, Chapter 2, apply.

2.3.2 *Minimum sector altitude/terminal arrival altitude.* For the application of the minimum sector altitude, the provisions of Part I, Section 4, Chapter 8, apply except that only a single omnidirectional sector shall be established. The sector is centred on the PRP/MAPt. The PRP/MAPt must be provided in the database as the reference point serving the same purpose as the ARP in approaches to aerodromes. For the application of the terminal arrival altitude the provisions of Part III, Section 2, Chapter 4 apply.

2.4 TERMINAL CRITERIA

2.4.1 *Approach configuration.* The basic T/Y approach configuration affords flexibility and standardization of procedure design and should therefore be considered as the first option in procedure design.

2.4.2 *Holding.* For holding patterns, the track specified for the inbound leg should be the same as the track for the initial segment if the holding fix is the IAF or the intermediate segment if the holding fix is the IF. The track for the inbound leg should not differ from the initial or the intermediate track, as appropriate, by more than 30°.

2.4.3 The initial and intermediate segments have minimum lengths to accommodate turn distance/minimum stabilization distance (MSD). The length of the turning component is the minimum stabilization distance for the angle turn at the IAF and IF can be determined from the formulas in Part III, Section 2, Chapter 1.

2.4.4 The outer boundary of turn areas is designed using a wind spiral or a bounding circle derived by applying an omnidirectional wind to the ideal flight path. On the outer edge of the turn, and after the turn in the case of an overshoot, wind spirals are constructed from the limits of the primary area, based on the parameters of Part I, Section 4, Chapter 3, 3.6.2 a) through g), and at a distance equal to: $[\min(r, r \tan(\theta/2)) - ATT - d(s)]$ before the waypoint. Additionally, in order to protect the aircraft within the required range of speeds, the outer limit of the primary area is expanded as shown in Figure IV-2-1, and a constant secondary area is applied during the turn.

2.5 INITIAL APPROACH SEGMENT

2.5.1 The initial approach segment begins at the IAF and ends at the IF.

2.5.2 *Alignment.* The initial track shall not differ from the intermediate segment track by more than 120°.

2.5.3 *Area.* See Figure IV-2-1 for the areas of initial, intermediate and final approach segments. See also Part III, Section 3, Chapter 3, Figure III-3-3-2.

2.5.3.1 *Length.* The initial approach segment should not exceed 18.52 km (10.00 NM), unless operational requirements make a longer segment necessary. Construct the IAF within 46.30 km (25.00 NM) of the PRP. The minimum length is governed by the magnitude of the turn required at the IAF. The initial approach segment is designed for helicopters flying the procedure at speeds up to 220 km/h (120 KIAS). Where an operational requirement exists, the segment may be designed for an airspeed not exceeding 165 km/h (90 KIAS), in which case the approach plate will be annotated “Speed limited to 165 km/h (90 KIAS)”.

2.5.3.2 *Area width.* See Part III, Section 1, Chapter 2, Tables III-1-2-9 and III-1-2-10.

2.5.4 *Obstacle clearance.* The area considered for obstacle clearance extends from the earliest IAF to the nominal position of IF. The general criteria for obstacle clearance applies, see Part I, Section 4, Chapter 3, 3.3.4. Obstacle clearance required in the primary area is 300 m (1 000 ft), tapering uniformly to zero from the edge of the primary area to the outer edge of the secondary area.

2.5.5 *Descent gradient.* Optimum descent gradient is 6.5 per cent. Where a higher descent gradient is required, the recommended maximum is 10 per cent; however, where an operational requirement exists, a gradient of as much as 13.2 per cent may be authorized, provided the speed is restricted to a maximum of 165 km/h IAS (90 kt IAS) and provided the gradient used is depicted on the approach charts.

2.6 INTERMEDIATE APPROACH SEGMENT

2.6.1 The intermediate segment begins at the IF and ends at the FAF. A fly-by waypoint is recommended at the IF unless an operational imperative exists to use a flyover waypoint.

Note.— *The FAF is always defined by a fly-by waypoint, even if there is no turn over the FAF.*

2.6.2 The intermediate approach segment should be aligned with the final approach segment. If a turn at the FAF is necessary, it shall not exceed 60°.

2.6.3 *Area.* See Part III, Section 3, Chapter 3, Figure III-3-3-2, Intermediate and final segments.

2.6.3.1 *Length.* The optimum length is 5.56 km (3.00 NM). It shall not be less than 3.70 km (2.00 NM), and shall not exceed 18.52 km (10.00 NM). The minimum length is governed by the magnitude of the turn required at the IF. The intermediate approach segment is designed for helicopters flying the procedure at speeds up to 220 km/h (120 KIAS). Where an operational requirement exists, the segment may be designed for an airspeed not exceeding 165 km/h (90 KIAS), in which case the approach plate will be annotated “Speed limited to 165 km/h (90 KIAS)”.

2.6.3.2 *Width.* See Part III, Section 1, Chapter 2, Tables III-1-2-9 and III-1-2-10.

2.6.4 *Obstacle clearance.* The area considered for obstacle clearance extends from the earliest IF to the nominal position of FAF. The general criteria for obstacle clearance applies, see Part I, Section 4, Chapter 4, 4.3.2, “Obstacle clearance”. The obstacle clearance in the primary area is 150 m (492 ft), tapering uniformly to zero from the edge of the primary area to the outer edge of the secondary area.

2.6.5 *Descent gradient.* Because the intermediate approach segment is used to prepare the aircraft speed and configuration for entry into the final approach segment, this segment should be flat. If a descent gradient is necessary, the maximum permissible gradient will be 10 per cent. When an operational requirement exists, a gradient of as much as 13.2 per cent may be authorized, provided the speed is restricted to a maximum of 165 km/h IAS (90 kt IAS) and provided the gradient used is depicted on approach charts. The descent gradient should be calculated in accordance with Part III, Section 2, Chapter 3, 3.3.3, “Descent gradient”.

2.7 FINAL APPROACH SEGMENT

2.7.1 The final approach segment begins at the FAF (fly-by) and ends at the MAPt (flyover). All approaches will be to a point in space where the pilot should have sufficient visual reference to continue the approach and landing to the intended landing site or initiate a missed approach.

2.7.2 *Alignment.* For point-in-space approaches there are no alignment requirements in the final approach segment.

2.7.3 *Area.* See Part III, Section 3, Chapter 3, Figure III-3-3-2.

2.7.3.1 The area considered for obstacle clearance begins at the earliest FAF position and ends at the nominal position of the MAPt.

2.7.3.2 *Length.* The optimum length is 5.92 km (3.20 NM). The minimum length is governed by the magnitude of the turn required at the FAF. Procedures are normally designed for helicopters flying the approach up to 130 km/h (70 KIAS). For specific cases, where the final may be designed to accommodate speeds up to 165 km/h (90 KIAS), the missed approach must also be designed to accommodate 165 km/h (90 KIAS). The maximum speed for which the final and missed approach segments are designed must be clearly annotated on the approach chart.

2.7.3.3 *Width.* See Part III, Section 1, Chapter 2, Tables III-1-2-9 and III-1-2-10.

2.7.4 *Obstacle Clearance.* Primary area minimum obstacle clearance (MOC) is 75 metres (246 ft) tapering uniformly to zero from the edge of the primary area to the outer edge of the secondary area.

2.7.5 *Descent gradient.* Optimum descent gradient is 6.5 per cent. Where a higher descent gradient is necessary, the recommended maximum is 10 per cent. However, where an operational imperative exists, and the magnitude of turn at the FAF is less than or equal to 30°, a gradient of as much as 13.2 per cent may be authorized, provided the speed is restricted to a maximum of 130 km/h IAS (70 kt IAS) and provided the gradient used is depicted on approach charts. The final segment is calculated from the FAF altitude at the plotted position of the FAF to the OCA/H at the plotted position of the MAPt.

2.8 MISSED APPROACH SEGMENT

2.8.1 *General.* The missed approach segment begins at the earliest MAPt (flyover) position and ends at a holding point designated by an MAHF (flyover) or to a clearance limit. Optimum routing is straight ahead to a direct entry into holding at the MAHF.

2.8.2 *Longitudinal tolerance of the MAPt.* The longitudinal tolerance of the MAPt will be calculated as described at Part I, Section 4, Chapter 6, 6.1.6.2.1, “MAPt tolerance when MAPt is defined by a navigational facility or fix”.

2.8.3 *Calculation of start of climb (SOC).* The SOC point will be calculated as described at Part I, Section 4, Chapter 6, 6.1.6.2, “Determining SOC with an MAPt defined by a navigation facility or fix”, except that the transitional tolerance (X) is the distance a helicopter traverses during 5 seconds of flight at 130 km/h (70 KIAS) or 165 km/h (90 KIAS) converted to TAS.

2.8.4 *Missed approach area.* The missed approach area shall commence at the beginning of the MAPt longitudinal tolerance at a width equal to the final approach area at that point. At that point, the area splays at 15° on each side of the missed approach course, to account for the decrease in GNSS receiver display sensitivity from ± 0.56 km (0.30 NM) to ± 1.85 km (1.00 NM) to a total width of ± 4.07 km (2.20 NM). If the first waypoint is reached prior to the area reaching ± 4.07 km (2.20 NM) the splay continues to 4.07 km (2.20 NM). For missed approach procedures with GNSS receivers which do not provide continuous track guidance after the MAPt see Figures IV-2-2 and IV-2-3. Turning missed approach with track specified to MAHF should be restricted to systems providing continuous track guidance after the missed approach waypoint and the approach procedure should be clearly annotated. See Figure IV-2-4.

2.8.5 *Straight missed approach.* The criteria governing straight missed approach apply (see Part I, Section 4, Chapter 6, 6.3, “Straight missed approach”). Note also that track guidance is available for the missed approach by the nomination of a GNSS fix(es).

2.8.6 *Turning missed approach.* The turn calculations are based on the turn parameters in Part I, Section 4, Chapter 6, 6.4.3. The wind spiral or bounding circle is applied to the boundary of the primary area, and the outer boundary of the secondary area is constructed by applying a constant width area. For missed approach procedures with GNSS receivers which do not provide continuous track guidance after the MAPt, see Figures IV-2-2 and IV-2-3. Turning missed approach with track specified to MAHF should be restricted to systems providing continuous track guidance after the missed approach waypoint and the approach procedure should be clearly annotated. See Figure IV-2-4.

2.8.6.1 Turn parameters.

2.8.6.1.1 *Indicated airspeed.* The speed for the final missed approach is 165 km/h (90 KIAS). However, where operationally required to avoid obstacles, reduced speeds as slow as 130 km/h (70 KIAS) may be used, provided the procedure is annotated “**Missed approach turn limited to 130 km/h (70 KIAS) maximum**”.

2.8.6.1.2 *Alignment.* The maximum difference between the inbound track and outbound track at MATF is a maximum of 120°.

2.8.6.1.3 *Length.* Where an operational requirement exists to avoid obstacles, an MATF may be used. In this case, the MSD for the turn point must be applied after SOC. The minimum length after the turn is determined by the MSD required for the outbound segment. Refer to the method in Part III, Section 2, Chapter 1.

2.8.7 *Climb gradient.* The nominal climb gradient of the missed approach surface is 4.2 per cent (24:1). Higher gradients may be considered with operational approval when an operational requirement exists. When a gradient other than the nominal gradient is used in the construction of the missed approach procedure the gradient required must be annotated on the instrument approach chart. In addition to the OCA/H for the specified gradient, the OCA/H applicable to the nominal gradient must also be shown.

2.8.8 The MOC is 40 m (130 ft) for turns exceeding 15°. (See Part I, Section 4, Chapter 6.)

2.9 PinS APPROACH PROCEDURES WITH A “PROCEED VISUALLY” INSTRUCTION

Note.— In circumstances where a “proceed visually” instruction is not suitable or possible, a PinS approach procedure with a “proceed VFR” instruction can be designed (see section 2.10).

2.9.1 *General.* A direct visual segment or a manoeuvring visual segment connects the PinS (the MAPt) to the heliport or the landing location. This provides the pilot flying a PinS instrument approach procedure with a visual segment to proceed visually from the MAPt to the heliport or landing location.

Note.— This connection can also be accomplished via a route visual segment. Procedure design criteria for route visual segments are currently under development.

2.9.2 *Direct-visual segment (VS).* The Direct-VS connects the PinS to the landing location; this can be either direct to the landing location or via a descent point where a limited track change may occur. The Direct-VS provides the pilot flying a PinS instrument approach procedure with a visual segment to proceed visually from the MAPt to the landing location.

2.9.2.1 *General.* The following paragraphs provide a description of the components of the Direct-VS. See Figures IV-2-5 and IV-2-6.

2.9.2.1.1 The landing location shall meet the dimensions of the non-instrument heliport final approach and take-off area (FATO) and safety area (SA) as defined in Annex 14, Volume II.

2.9.2.1.2 The obstacle clearance surface (OCS) is continued from the MAPt to the landing location and is similar to an obstacle limitation surface (OLS) provided in Annex 14, Volume II, and a visual segment surface (VSS).

2.9.2.1.3 The three obstacle identification surfaces (OIS) provide the pilot obstacle awareness in the vicinity of the landing location.

2.9.2.1.4 A descent point (DP) defined by track and distance from the MAPt may be necessary to identify the point at which the aircraft can descend below the OCA and begin a visual descent to the landing location.

2.9.2.1.5 The visual segment descent angle (VSDA) is the angle from the MDA at either the MAPt or DP to the landing location HRP at HCH.

2.9.2.2 *Obstacle clearance surface (OCS) and obstacle identification surface (OIS)*

2.9.2.2.1 *OCS alignment, slope, origination base width, and lateral dimensions.* The OCS is aligned symmetrically on the course between HRP and MAPt. If a DP is established with a change of track at the DP, the OCS is aligned symmetrically on the course between the HRP and the DP. See Figures IV-2-7, IV-2-8 and IV-2-9.

2.9.2.2.1.1 The OCS originates at the outer edge of the landing location SA.

2.9.2.2.1.2 The width of the OCS at its origin is equal to the width of the SA.

2.9.2.2.1.3 The outer edges splay from their origins at the edge of the SA, symmetrically around the OCS centre line direction, to an overall maximum width of 120 m, at which point the outer edges parallel the OCS centre line. For the provision of day-only operations the splay is 10 per cent. For night operations the splay angle is increased to 15 per cent.

2.9.2.2.1.4 The elevation of the origin of the OCS is equal to the landing location elevation.

2.9.2.2.1.5 The OCS slopes upward at nominally 12.5 per cent from the heliport elevation to the point where the surface reaches the altitude of the OCA minus the MOC established for the final approach segment (FAS).

Note 1.— The calculation of the SA size and the SA outer edges used to establish the origination base width is aircraft dependent and needs to be provided with other landing location information to develop a Direct-VS for a helicopter PinS instrument approach procedure.

Note 2.— The nominal 12.5 per cent OCS slope is consistent with a VSDA of 8.3° and an OCS of 1.12° below VSDA.

2.9.2.2.2 *Sloping OIS inner and outer lateral dimensions.* There are two sloping OIS areas; one on each side of the OCS.

2.9.2.2.2.1 The sloping OIS inner and outer edges originate at the outer edge of the OCS origin (at the outer edge of the SA).

2.9.2.2.2.2 The inner edge of the OIS extends to the limit of the OCS outer edge.

2.9.2.2.2.3 The outer edge of the sloping OIS is established by connecting the origin directly to the outer edge of the primary areas at the MAPt/DP.

2.9.2.2.2.4 The origin of the sloping OIS is established at the elevation of the landing location.

2.9.2.2.2.5 The inner edge of each sloping OIS rises in the vertical plane at the same gradient as the OCS.

2.9.2.2.2.6 The outer edge of the sloping OIS rises in the vertical plane at the same gradient as the OCS.

2.9.2.2.3 *Level OIS.* A level OIS surrounds the outer lateral limits of the sloping OIS.

2.9.2.2.3.1 The inner edge of the level OIS abuts the outer edge of the sloping OIS.

2.9.2.2.3.2 The outer edge of the level OIS originates at each outer edge of the FAS secondary area and connects tangentially with a 750 m (0.40 NM) radius circle centred on the HRP.

2.9.2.2.3.3 The altitude of the level OIS is equal to the OCA for the instrument approach procedure minus 30 m.

2.9.2.3 *Visual segment descent angle (VSDA)*. The VSDA describes the nominal descent path of the aircraft in the visual segment. The VSDA is derived from the slope of the OCS and is equivalent to the OCS slope plus 1.12°. The maximum VSDA is 8.3°. The VSDA originates at MAPt, or DP if established, at MDA/H, and terminates at HCH over the HRP.

2.9.2.4 *DP establishment, alignment, OCS dimensions, FAS extension*. If the VSDA reaches an altitude equal to OCA at a point that is between the latest ATT of the MAPt and the HRP, then a DP is established. The associated DP alignment course is between HRP and DP. In such a case, an additional OCS is required. This additional OCS is established as a level surface equal in dimension to the FAS primary area and at an altitude of OCA minus MOC; it extends beyond the MAPt to the DP. The semi-width of this OCS extension is equal to the FAS primary area semi-width extended from the MAPt to abeam the DP.

2.9.2.5 *Obstacle clearance*. No obstacles shall penetrate the Direct-VS OCS. Obstacles that penetrate the sloping OIS or the level OIS shall be documented and should be charted.

2.9.2.6 *Direct-visual segment length*. The length of the visual segment should be selected to provide sufficient visual references from the MAPt to the landing location whilst also providing sufficient distance to decelerate, descend and land the aircraft at the landing location.

2.9.2.6.1 The maximum visual segment length shall be 3.00 km (1.62 NM).

2.9.2.6.2 The optimum visual segment length is dependent on the maximum speed in the final approach segment of the instrument procedure and is as follows:

130 km/h (70 KIAS): 1.20 km (0.65 NM)

165 km/h (90 KIAS): 2.00 km (1.08 NM).

2.9.2.6.3 The minimum visual segment length is dependent on the maximum speed in the final approach segment of the instrument procedure and shall be as follows:

130 km/h (70 KIAS): 1.00 km (0.54 NM)

165 km/h (90 KIAS): 1.60 km (0.85 NM).

2.9.2.7 *Course change*. Course changes are permitted at either the MAPt or the DP (if established) but not at both. The maximum course change is 30°.

2.9.3 Manoeuvring-visual segment (VS)

2.9.3.1 A Manoeuvring-VS is designed to protect a manoeuvre whereby the pilot visually acquires the heliport or landing location, or visual references associated with it, by the MAPt and visually manoeuvres around the heliport or landing location to land from a direction other than directly from the MAPt.

2.9.3.1.1 This Manoeuvring-VS is protected by a level obstacle clearance surface (OCS), the obstacle limitation surfaces (sloping OCS and OIS) and the safety area (SA) associated with the FATO (See Annex 14, Volume II, Chapter 3, section 3.1).

2.9.3.1.2 The OCH for a PinS procedure followed by a manoeuvring-visual segment shall not be less than 90 m (295 ft) above the heliport/landing location elevation.

2.9.3.2 Level obstacle clearance surface (OCS)

2.9.3.2.1 The level OCS is a level surface at an altitude of OCA – 76 m (250 ft).

2.9.3.2.2 From the MAPt to abeam the HRP the level OCS is aligned symmetrically on the course between HRP and MAPt with a semi-width of 741 m (0.4 NM). Beyond the HRP, this surface connects tangentially with a circle centred on the HRP, this circle having a radius equal to 741 m (0.4NM).

2.9.3.3 Obstacle identification surface (OIS)

2.9.3.3.1 The OIS provides awareness in the area where the pilot is expected to manoeuvre before being aligned on the centre line of the approach surface.

2.9.3.3.2 Definition of the “manoeuvring area”

2.9.3.3.2.1 The “manoeuvring area” corresponds to the area where the pilot is expected to manoeuvre from the MAPt to the point where it is aligned on the final landing.

2.9.3.3.2.2 The “manoeuvring area” is the area enclosed by all the lines that originate at the MAPt and connect with a “base turn area” aligned symmetrically around the centre line of the approach surface (see Figures IV-2-10 and IV-2-11).

Note 1.— If more than one approach direction has to be considered, the final “manoeuvring area” is the combination of all the “manoeuvring areas” obtained.

Note 2.— Trajectories that have been considered to define the shape of this “manoeuvring area” are:

- a) *the pilot flies at the OCA/H directly from the MAPt to the heliport/landing location and then performs a base turn to descend and align on the centre line of the approach surface;*
- b) *the pilot starts from the MAPt but diverges from the “MAPt-HRP” axis in order to manoeuvre to align on the centre line of the approach surface.*

2.9.3.3.2.3 Description of “base-turn area” (see Table IV-2-1 and Figure IV-2-12).

2.9.3.3.2.3.1 The “base turn area” is defined by an angle α each side of the centre line of the approach surface (to protect both possible manoeuvres of a base turn (on the right side and on the left side) to join the centre line of the approach surface) and by a radius r .

2.9.3.3.2.3.2 Radius (r) of the “base turn area”:

- a) if the OCH of the procedure is equal to or less than 183 m (600 ft) above the heliport/landing location elevation, r is constant and equal to 1 482 m (0.8 NM);
- b) if the OCH of the procedure is more than 183 m (600 ft) above the heliport/landing location elevation, r increases linearly (185 m (0.1 NM) for each additional 30 m (100 ft) above 183 m (600 ft)).

2.9.3.3.2.3.3 Angle (α) of the “base turn area”:

- a) if the OCH of the procedure is equal to or less than 183 m (600 ft) above the heliport/landing location elevation, α is constant and equal to 50°;

- b) if the OCH of the procedure is more than 183 m (600 ft) above the heliport/landing location elevation and equal to or less than 304 m (1 000 ft) above the heliport/landing location elevation, α decreases linearly (5° for each additional 30 m (100 ft) above 183 m (600 ft));
- c) if the OCH of the procedure is more than 304 m (1 000 ft) above the heliport/landing location elevation, α is constant and equal to 30° .

Table IV-2-1. Definition of the “base turn area” for a set of OCH values

- a) Units in metres for OCH and r:

OCH	93 m*	123 m*	153 m*	183 m*	213 m*	243 m*	273 m*	304 m*
r	1 482 m	1 482 m	1 482 m	1 482 m	1 667 m	1 852 m	2 037 m	2 222 m
α	50°	50°	50°	50°	45°	40°	35°	30°

* Height above the heliport/landing location elevation.

- b) Units in feet for the OCH and in NM for r:

OCH	300 ft*	400 ft*	500 ft*	600 ft*	700 ft*	800 ft*	900 ft*	1 000 ft*
r	0.8 NM	0.8 NM	0.8 NM	0.8 NM	0.9 NM	1 NM	1.1 NM	1.2 NM
α	50°	50°	50°	50°	45°	40°	35°	30°

* Height above the heliport/landing location elevation.

Note.— Taking into account the buffer of 741 m (0.4 NM) that will be applied to these values to define the OIS (see paragraph 2.9.3.3.2), these values are acceptable for all the operational scenarios regarding the temperature and the heliport or landing location elevation.

2.9.3.3.2.3.4 *Base turn area on one side of the MAPt-HRP axis.* When turns are limited to one side of the MAPt-HRP axis, and the turn over the HRP is greater than 30° , the base turn area may not be sufficient to contain the manoeuvre. In these circumstances (when $\alpha > 30^\circ$), the angle between the edge of the base turn area and the extended MAPt-HRP axis is held at 30° and results in an increase to the base turn area (see Figure IV-2-11 b)).

2.9.3.3.2.3.5 Where operationally beneficial, in order to extend the resulting “manoeuvring area”, the “base turn area” can be extended by using wider angles on one side or on both sides of the centre line of the approach surface.

2.9.3.3.3 OIS definition

2.9.3.3.3.1 The OIS is a level surface at a height of (OCH (height above the heliport/landing location elevation)/2 – 46 m (150 ft)) or at a height of 46 m (150 ft) above the heliport/landing location elevation, whichever is greater.

2.9.3.3.3.2 The OIS surface is defined by the “manoeuvring area” with an additional buffer of a value equal to 741 m (0.4 NM) (see Figures IV-2-13 and IV-2-14).

Note.— If all the directions to land have to be considered, the OIS is a surface aligned symmetrically on the course between the MAPt and the HRP and that connects tangentially with the two following circles: the circle centred on the MAPt and having a radius equal to 741 m (0.4 NM) and the circle centred on the HRP and having a radius equal to (r + additional buffer value) (see Figure IV-2-15).

2.9.3.4 Sloping OCS

2.9.3.4.1 The sloping OCS is aligned symmetrically on the centre line of the approach surface.

Note.— If more than one approach surface has to be considered, a sloping OCS is designed for each.

2.9.3.4.2 The sloping OCS originates at the outer edge of the heliport or landing location SA.

2.9.3.4.3 The width of the sloping OCS at its origin is equal to the width of the SA.

2.9.3.4.4 The outer edges splay from their origins at the edge of the SA, symmetrically around the centre line of the approach surface, to an overall maximum width of 120 m, at which point the outer edges parallel the centre line. For the provision of day-only operations, the splay is 10 per cent. For night operations, the splay angle is increased to 15 per cent.

2.9.3.4.5 The elevation of the origin of the sloping OCS is equal to the heliport or landing location elevation.

2.9.3.4.6 The sloping OCS slopes upward at nominally 12.5 per cent from the heliport or landing location elevation up to the point where the surface reaches the height of 152 m above HRP.

Note 1.— The calculation of the SA size and the SA outer edges used to establish the origination base width is aircraft dependent and needs to be provided with other heliport or landing location information to develop a manoeuvring-VS for a helicopter PinS instrument approach procedure.

Note 2.— The nominal 12.5 per cent OCS slope is consistent with an assumption of a descent angle of 8.3° for this final descent and the OCS of 1.12° below this descent angle.

2.9.3.5 Obstacle clearance

2.9.3.5.1 No obstacles should penetrate the level OCS or the sloping OCS. Obstacles that penetrate the OIS shall be documented and charted. Other obstacles may be documented and charted if deemed necessary even if they do not penetrate the different OIS.

2.9.3.5.2 Method for reducing OCA/H

2.9.3.5.2.1 Where operationally beneficial, a relevant obstacle infringing the level OCS less than 741 m (0.4 NM) from the HRP, may be ignored for this OCS assessment if:

- a) flyover of the heliport or landing location during the visual manoeuvre is prohibited;
- b) the obstacle is not inside the “manoeuvring area” that is reduced accordingly (see paragraph 2.9.3.5.2.2);
- c) the obstacle does not penetrate the sloping OCS and the IFR protection areas.

2.9.3.5.2.2 In order to disregard an obstacle as explained in paragraph 2.9.3.5.2.1, the “manoeuvring area” needs to be reduced as follows. As flyover of the heliport or landing location is prohibited, the “base turn area” (see paragraph 2.9.3.3.2.3) shall be defined only on one side of the centre line of the approach surface and the resulting “manoeuvring area” is an area delimited by the MAPt-HRP axis and the centre line of the approach surface (see Figures IV-2-16 and IV-2-17).

2.9.3.6 *Segment length.* The minimum MAPt/HRP distance is dependent on the maximum speed in the final approach segment of the instrument procedure and shall be as follows:

- a) 130 km/h (70 KIAS): 1.00 km (0.54 NM);
- b) 165 km/h (90 KIAS): 1.60 km (0.85 NM).

2.9.3.7 *Visibility requirements.* The visibility requirements to fly a manoeuvring visual segment shall not be less than the MAPt/HRP distance or than the value of r defined in paragraph 2.9.3.3.2.3.2, whichever is greater.

2.9.3.8 *Authorised IFR final approach segment direction.* Angle between the IFR final approach segment direction and the limits of the manoeuvring area defined in paragraph 2.9.3.3.2 shall not exceed 30° (see Figures IV-2-13, IV-2-14 and IV-2-15)).

2.9.3.9 *Specific charting requirements regarding the manoeuvring visual segment*

2.9.3.9.1 The centre line(s) of the approach surface(s) taken into account for the protection of this Manoeuvring visual segment shall be indicated on the chart.

2.9.3.9.2 The “manoeuvring area” (see paragraph 2.9.3.3.2) and obstacles that penetrate the OIS (see paragraph 2.9.3.5.1) shall be depicted on the chart.

2.9.3.9.3 If the method for reducing the OCA/H has been used (see paragraph 2.9.3.5.2), it shall be indicated on the chart that flyover of the heliport or landing location during the visual manoeuvre is prohibited. The “manoeuvring area”, reduced accordingly (see paragraph 2.9.3.5.2.2), shall be depicted on the chart and the area where the prominent obstacle exists shall be depicted as a “no manoeuvring area”.

2.10 VISUAL SEGMENT FOR PinS APPROACH PROCEDURE WITH A “PROCEED VFR” INSTRUCTION

2.10.1 Where a “proceed visually” instruction is not suitable or possible, a PinS approach procedure with a “proceed VFR” instruction shall be designed.

2.10.2 There is no obstacle protection in the visual segment. The pilot shall comply with VFR to see and avoid obstacles when proceeding from the MAPt to the heliport or landing location.

2.11 PinS APPROACH PROCEDURE WITH A “PROCEED VFR” INSTRUCTION HEIGHT ABOVE SURFACE (HAS) DIAGRAM

2.11.1 *General.* To aid the pilot in transition from IFR to VFR at the MAPt for a PinS approach procedure with a “proceed VFR” instruction, a HAS diagram shall be charted. The HAS diagram is centred on the MAPt and depicts the course into the MAPt.

2.11.2 *HAS diagram requirements.* The radius of the HAS diagram, centred on the MAPt of the PinS approach procedure with a “proceed VFR” instruction, is at least 1.5 km (0.8 NM). This minimum value may be increased depending on State-specific requirements for helicopter VFR operations. The difference in height between the OCA and the elevation of the highest terrain or water within 1.5 km (0.8 NM), or other higher value required by the State, of the MAPt shall be charted. The inbound course to the MAPt shall also be charted. An example of a HAS diagram is depicted in Figure IV-2-18. The HAS value in the example is 467 ft and the final approach course to the MAPt is 028°.

2.12 PROMULGATION

2.12.1 *Procedure identification.* PinS approaches shall be titled “RNAV(GNSS) or RNP XXX”, depending on the navigation specification, in accordance with Part III, Section 5, Chapter 1, where XXX is the final approach course. PinS approach procedures shall not be published on the same IAP chart as aeroplane (CAT A, B, C, D) and helicopter (CAT H) procedures to runways.

2.12.2 The plan view shall include:

- a) heliport/landing location name and elevation to the nearest metre or foot;
- b) bearing to the nearest degree, and distance to the nearest two-tenths of a kilometre or tenth of a nautical mile from the missed approach point (MAPt) to the heliport/landing location;
- c) textual instructions to “Proceed VFR from xxxx” (MAPt identifier) or “Proceed visually from xxxx” (MAPt identifier) or “Manoeuvre visually from xxxx” (MAPt identifier), as appropriate;
- d) obstacles, if not included in an inset; and
- e) a note that the procedure is for CAT H only.

2.12.3 For point-in-space approaches annotated “Proceed visually from (MAPt)” serving more than one heliport, the heliport name(s), heliport elevation(s), the bearing (to the nearest degree) and the distance (to the nearest two-tenths of a kilometre (tenth NM)) from MAPt to each HRP shall be included; e.g. **MCCURTAIN MEMORIAL HOSPITAL, ELEV 693’, 123/3.2.**

2.12.4 *Speed limitation.* Airspeed restrictions shall be depicted on the chart textually as “Maximum airspeed xxx km/h (xxx KIAS)” when less than 165 km/h (90 KIAS).

2.12.5 *Descent gradient.* Where an operational requirement exists, a gradient of as much as 13.2 per cent (800 ft/NM) may be authorized, provided that the gradient used is depicted on the approach chart.

2.12.6 Appropriate obstacles shall be charted (see 2.9.3.5.1).

2.12.7 An inset shall be used to show the following:

- a) obstacles that penetrate the OIS;
- b) final approach course to the MAPt;
- c) text for either “Proceed VFR from (MAPt)” or “Proceed visually from (MAPt)”, as appropriate;
- d) for “Proceed visually” PinS procedures with a direct visual segment, the descent point (DP), if established, and bearings and distances from MAPt to DP and from MAPt or DP to the heliport/landing location;

- e) for “Proceed visually” PinS procedures with a manoeuvring visual segment(s), only the ingress track(s) and the boundary of the manoeuvring area without dimensions are charted;
- f) for “Proceed visually” PinS procedures with a “no manoeuvring” area, the text “no manoeuvring” will be shown, along with the boundary of the “no manoeuvring” area. The “no manoeuvring” area shall be hachured;
- g) for “Proceed visually” PinS procedures where over-flight of the heliport or landing location is prohibited, the bearing and distance, from the MAPt to the heliport or landing location, on a line from the MAPt to the boundary of the prohibited over-flight area; and
- h) for “Proceed VFR” procedures, only a height above surface (HAS) diagram, which shall include the difference in height between the OCA and the elevation of the highest terrain or water surface and any relevant obstacles within 1.5km (0.8NM) of the MAPt.

Note.— The inset specified above is a separate framed diagram, located on the plan view, on the verso of the chart, or on a continuation sheet, which is charted to scale and is used to show pertinent information “close-in” to the heliport or landing location.

2.12.8 The inset for either type of PinS procedure shall not be used to depict instructions, non operational notes, descent gradients/angles, or missed approach track or instructions.

2.12.9 The profile view shall contain information relating to the instrument procedure profile and the direct visual segment profile, if it exists, with the text “Proceed VFR” or “Proceed visually”, as appropriate. There is no profile view information for either “Proceed VFR” or “Proceed Visually” with manoeuvring-visual segment procedures. The profile view of the direct visual segment shall include:

- a) fixes, altitudes and distances up to the MAPt;
- b) the profile and track from the MAPt to the heliport or landing location;
- c) the descent point if established;
- d) the descent angle from the MAPt or DP;
- e) the heliport crossing height (HCH);
- f) the text “Proceed visually”, which shall be located under the visual segment profile; and
- g) a descent table should be shown indicating descent angle and descent rate in metres per minute (feet per minute) for appropriate speeds for applicable segments, i.e. final approach fix (FAF) to step down fix (SDF), SDF to missed approach point (MAPt), and descent point (DP) to heliport reference point (HRP).

Note.— The descent table may be placed in the lower left or right corner of the plan view directly above the profile view.

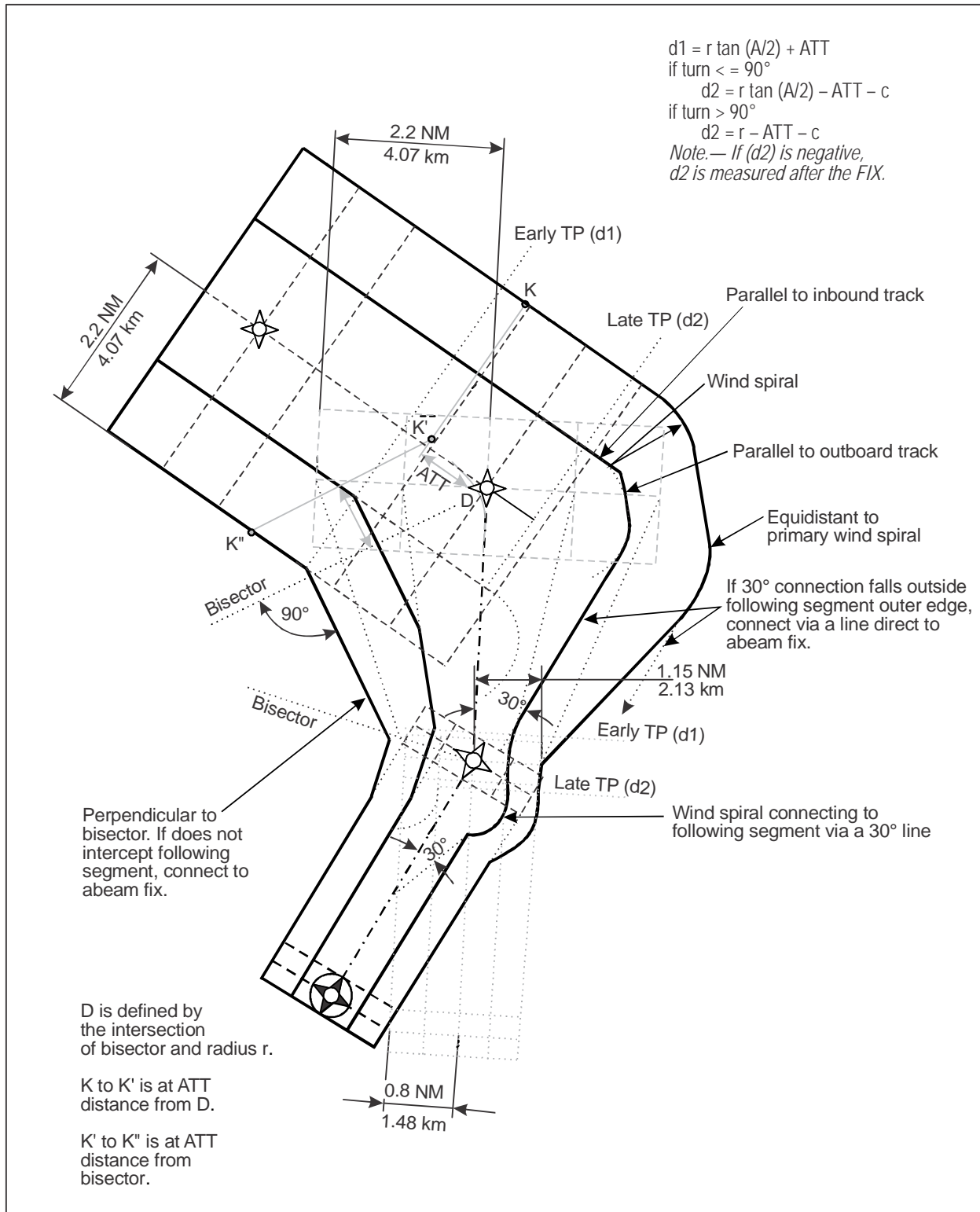

Figure IV-2-1. Initial, intermediate and final approach segments

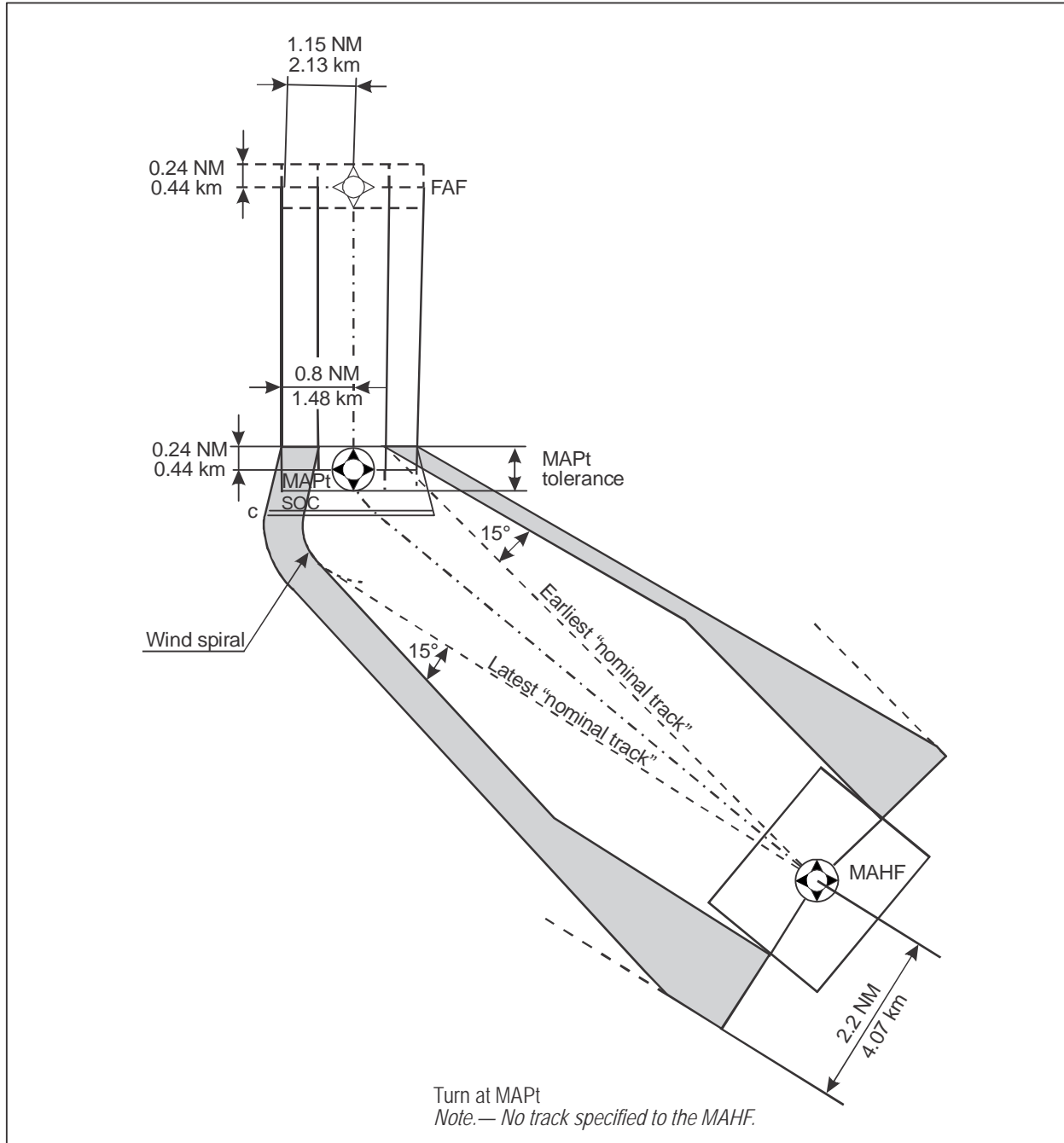

Figure IV-2-2. Turning missed approach

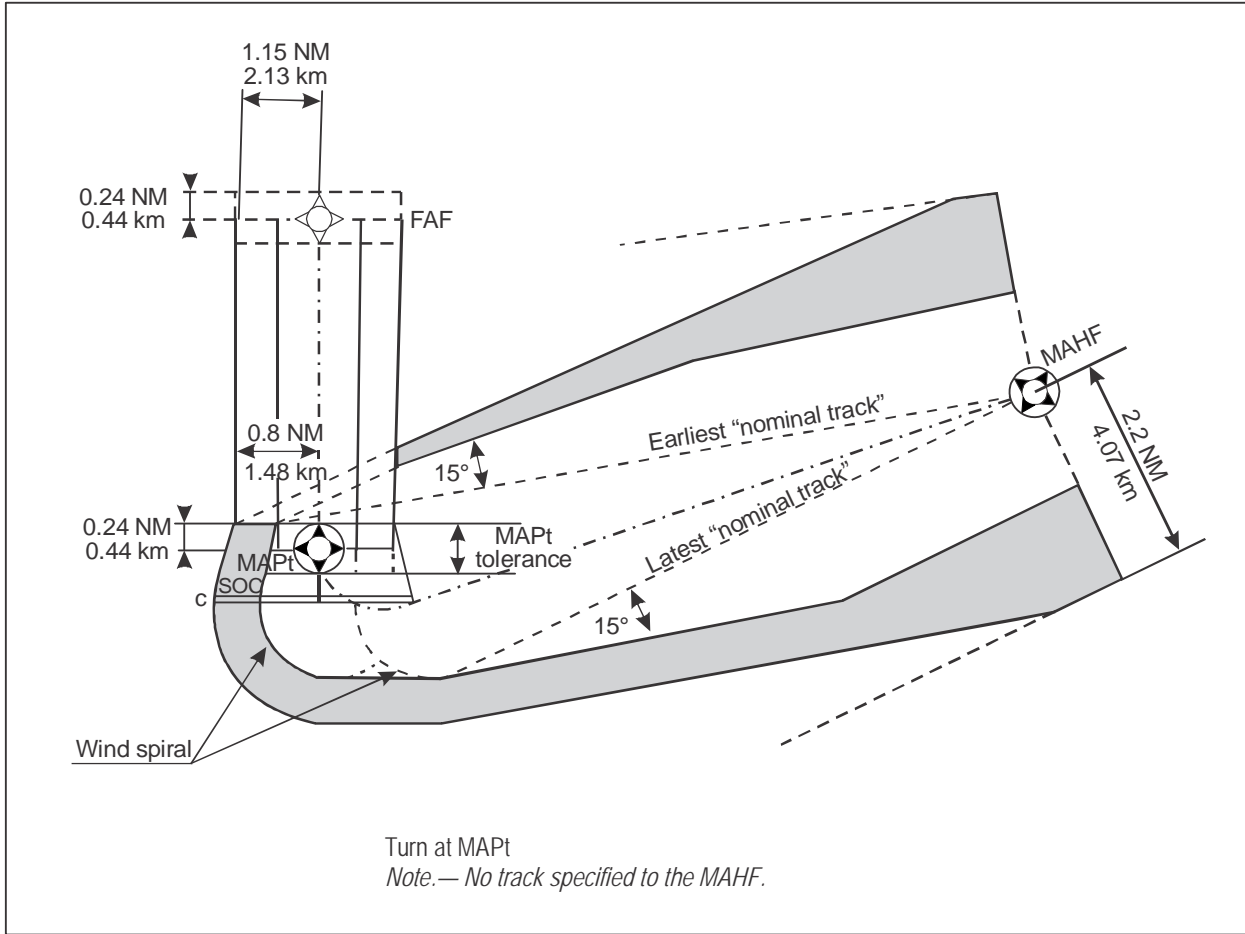

Figure IV-2-3. Turning missed approach with turn more than 90°

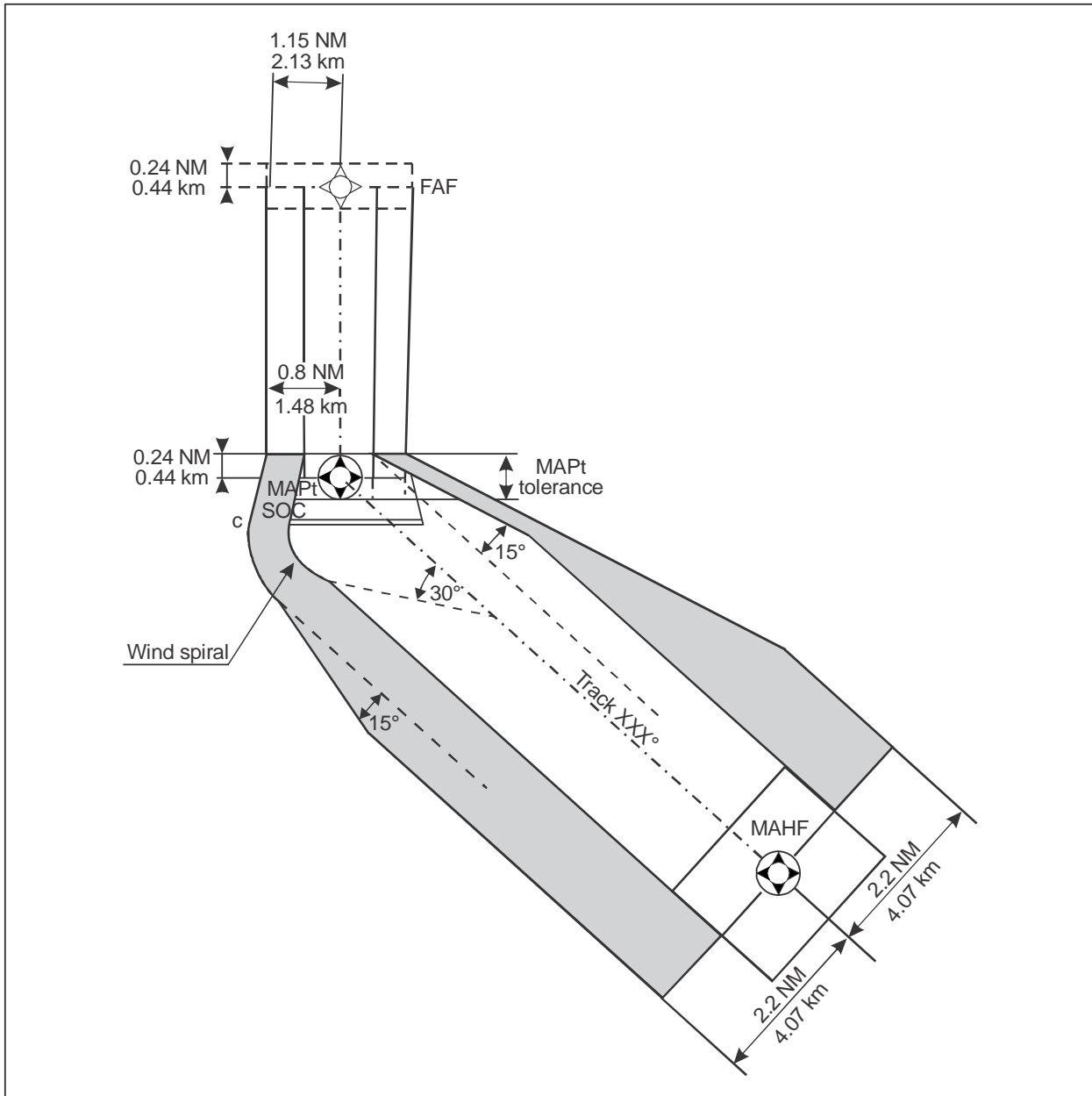

Figure IV-2-4. Turning missed approach with turn less than or equal to 90°

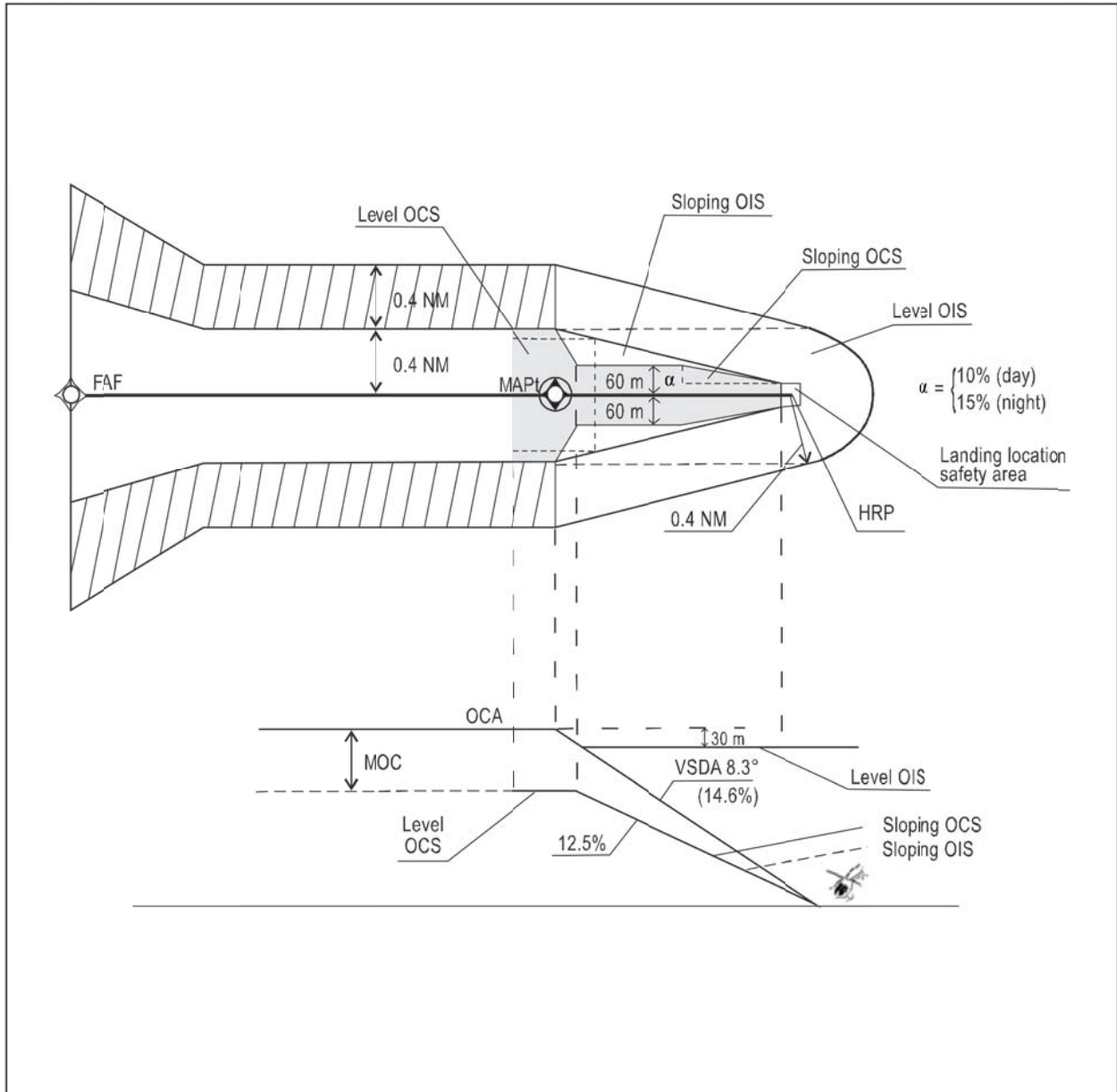

Figure IV-2-5. Direct-VS without DP and without course change

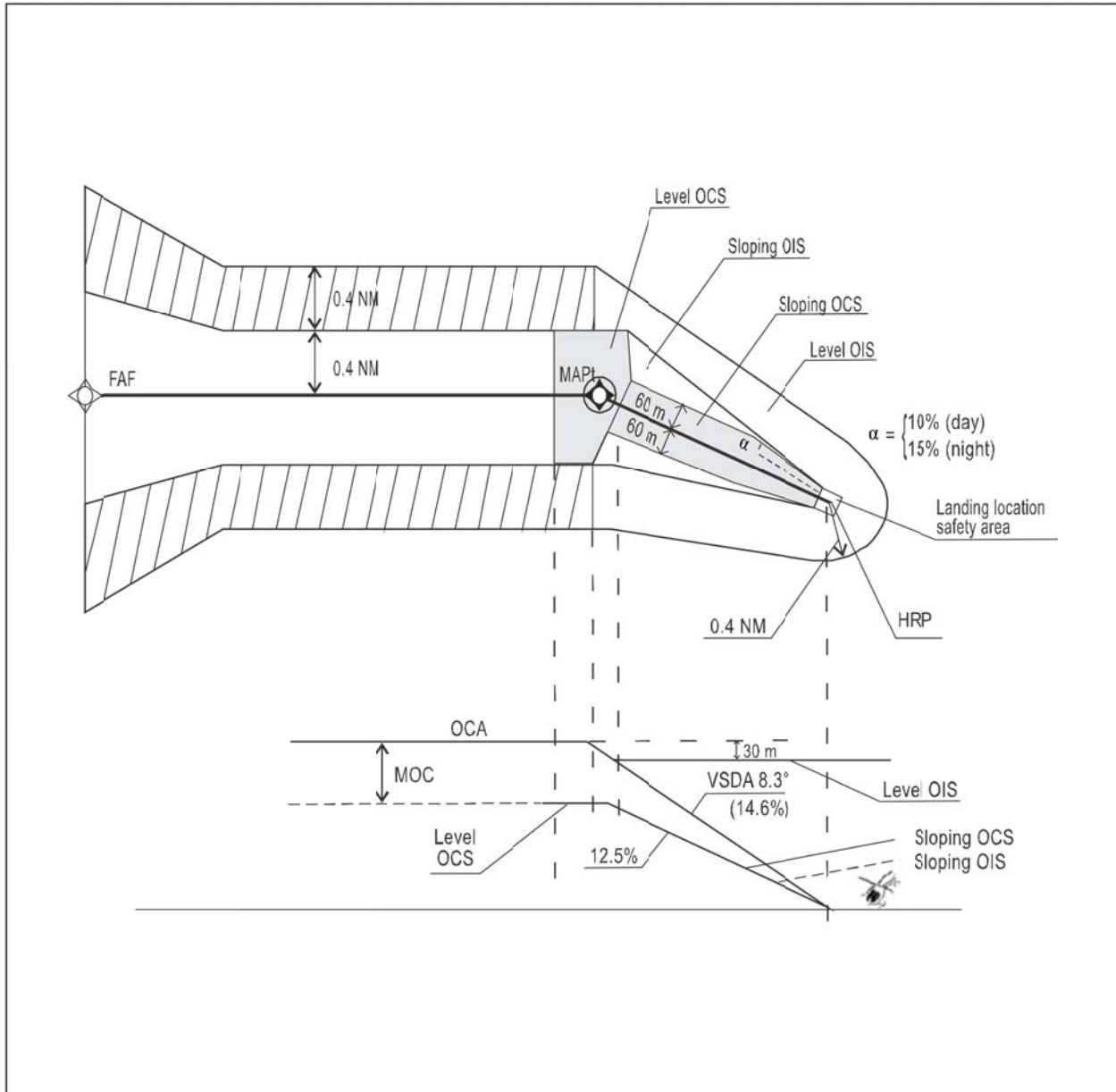

Figure IV-2-6. Direct-VS without DP and with 30° course change at MAPt

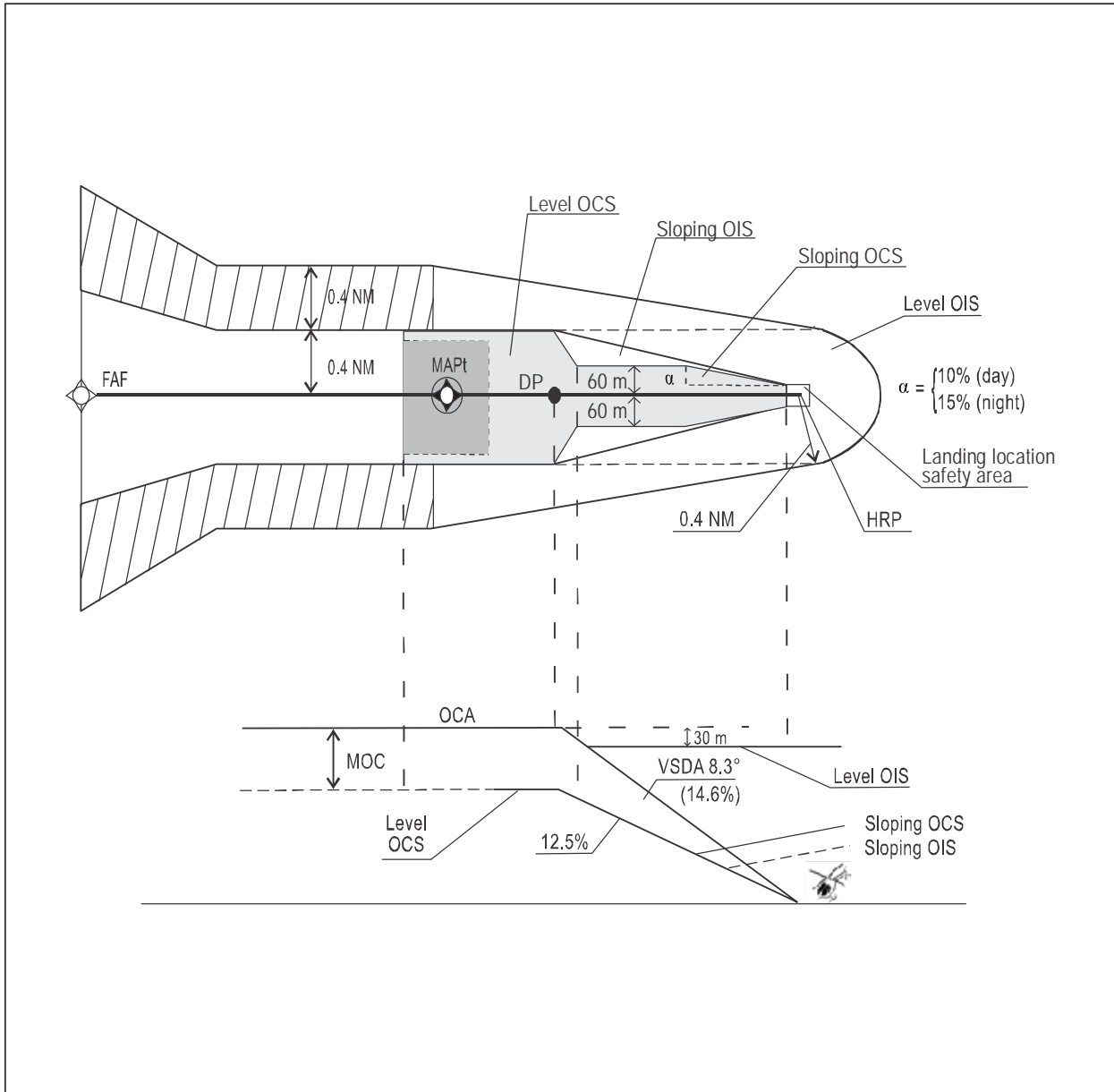

Figure IV-2-7. Direct-VS with DP and without course change

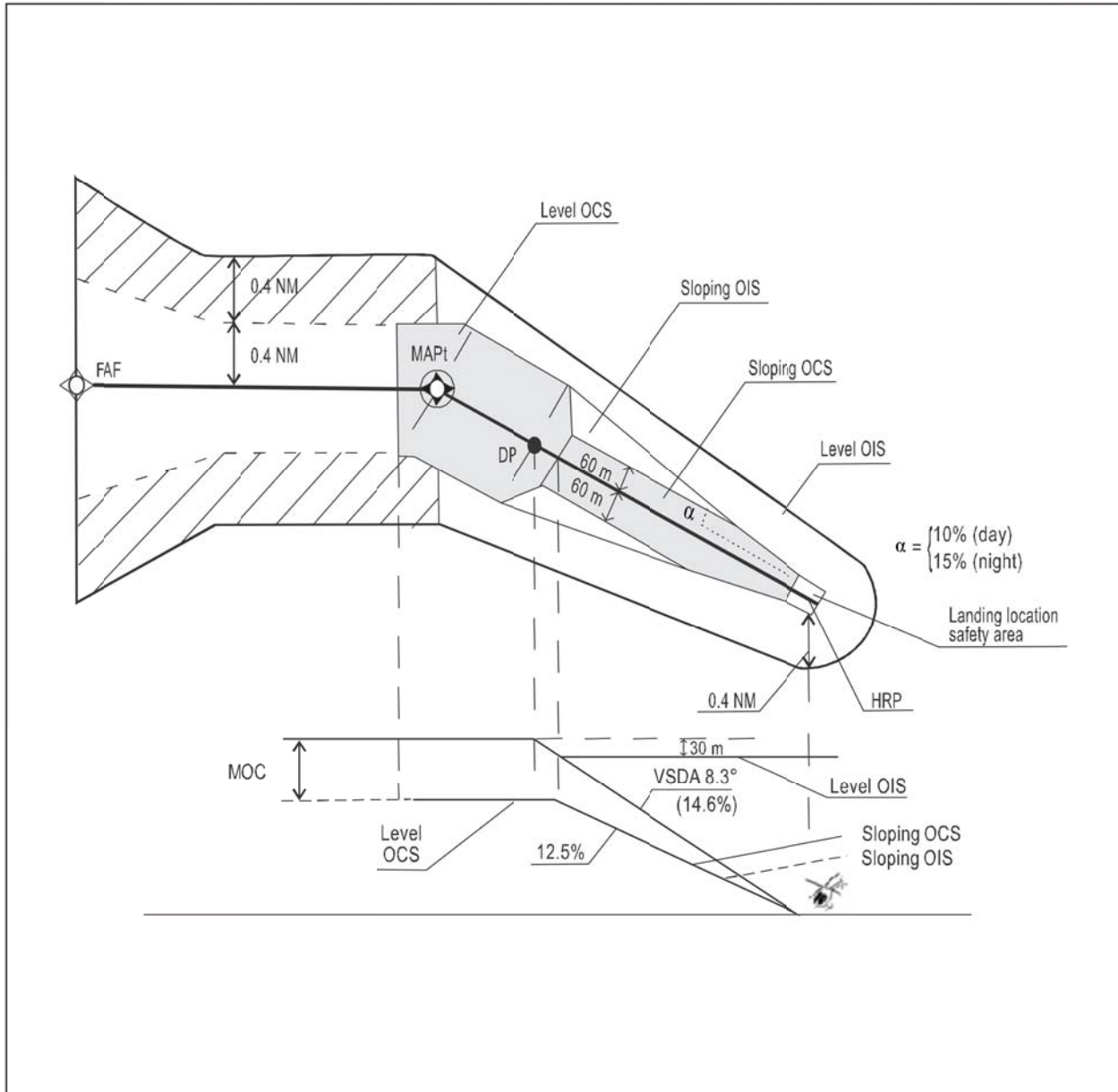

Figure IV-2-8. Direct-VS with DP and with 30° course change at MAPt

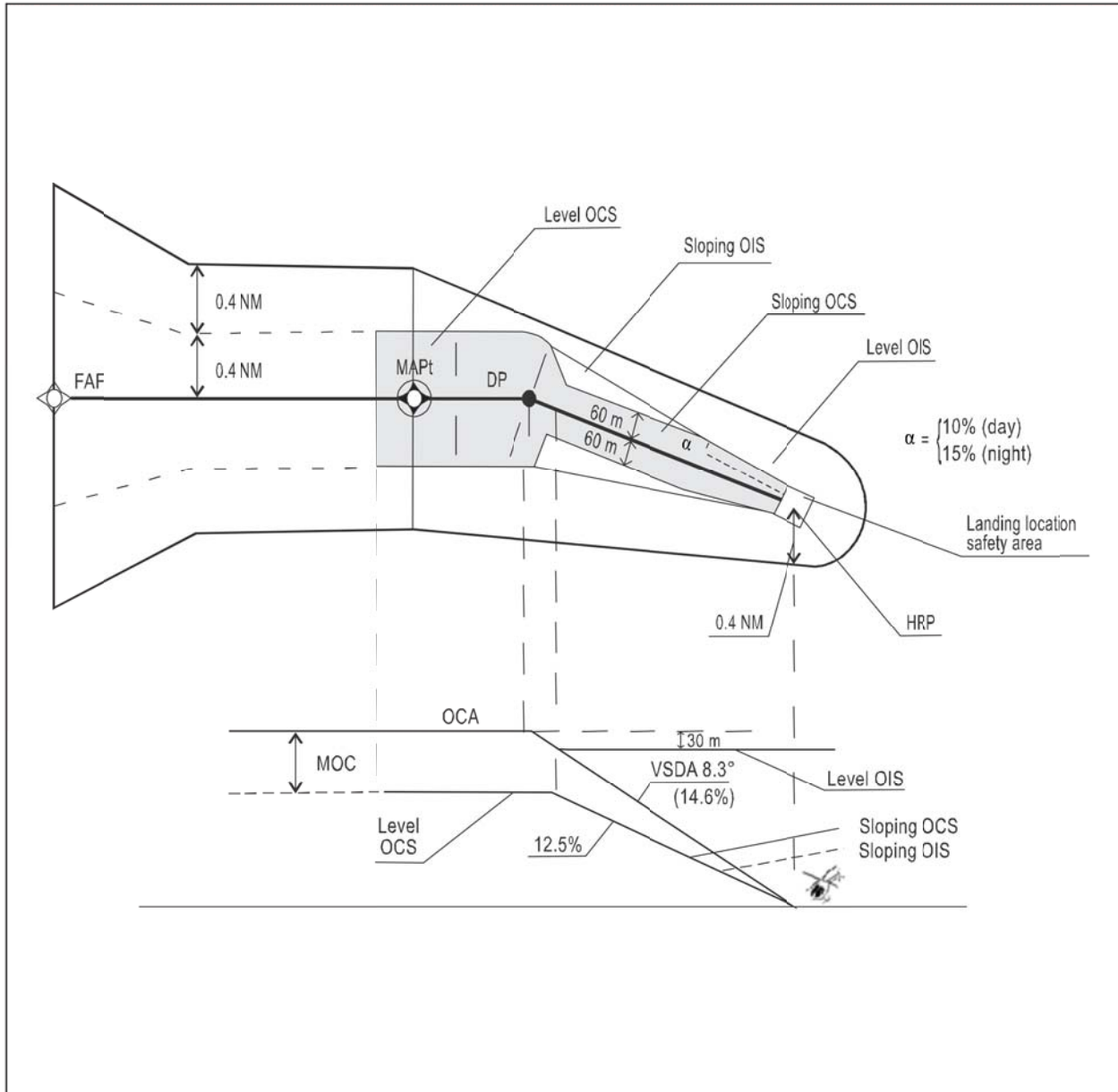

Figure IV-2-9. Direct-VS with DP and with 30° course change at DP

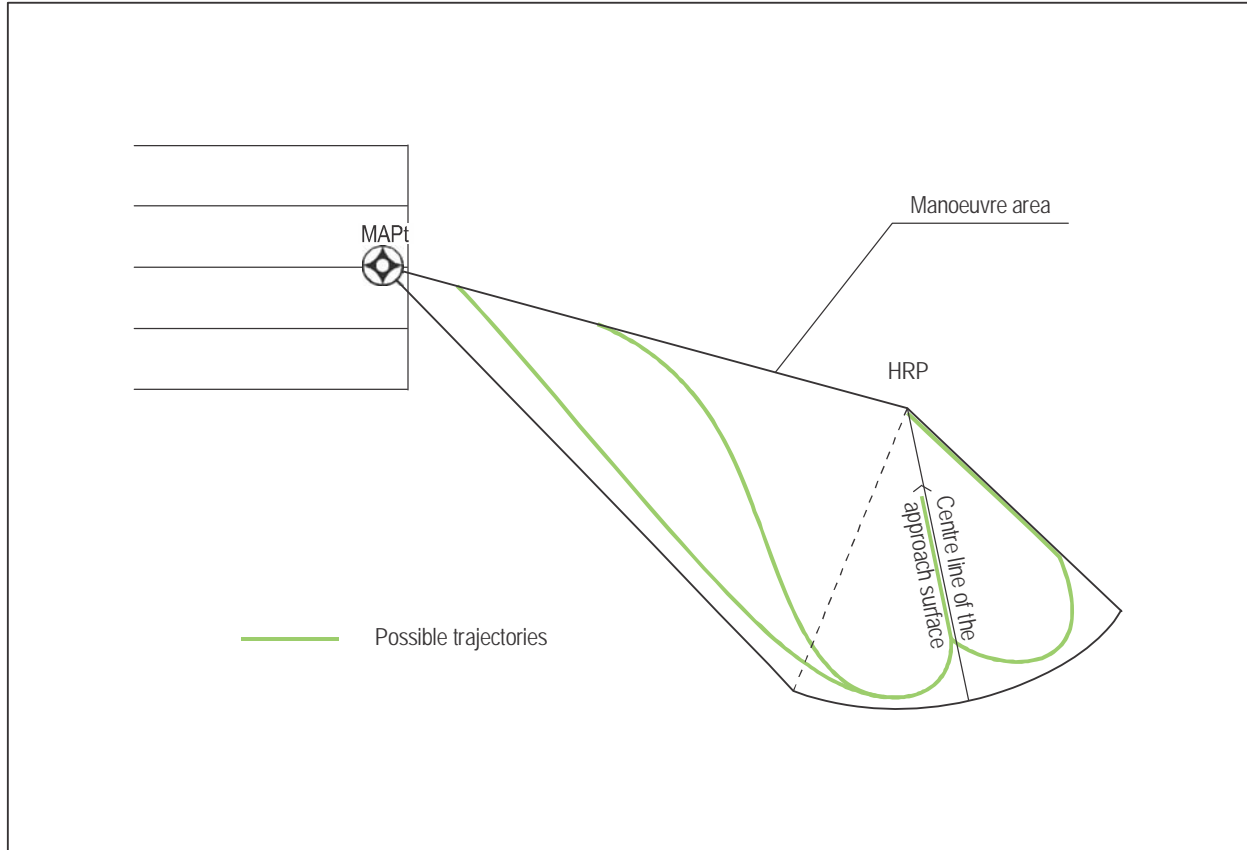

Figure IV-2-10. Representation of the possible trajectories defining the “Manoeuvring area”

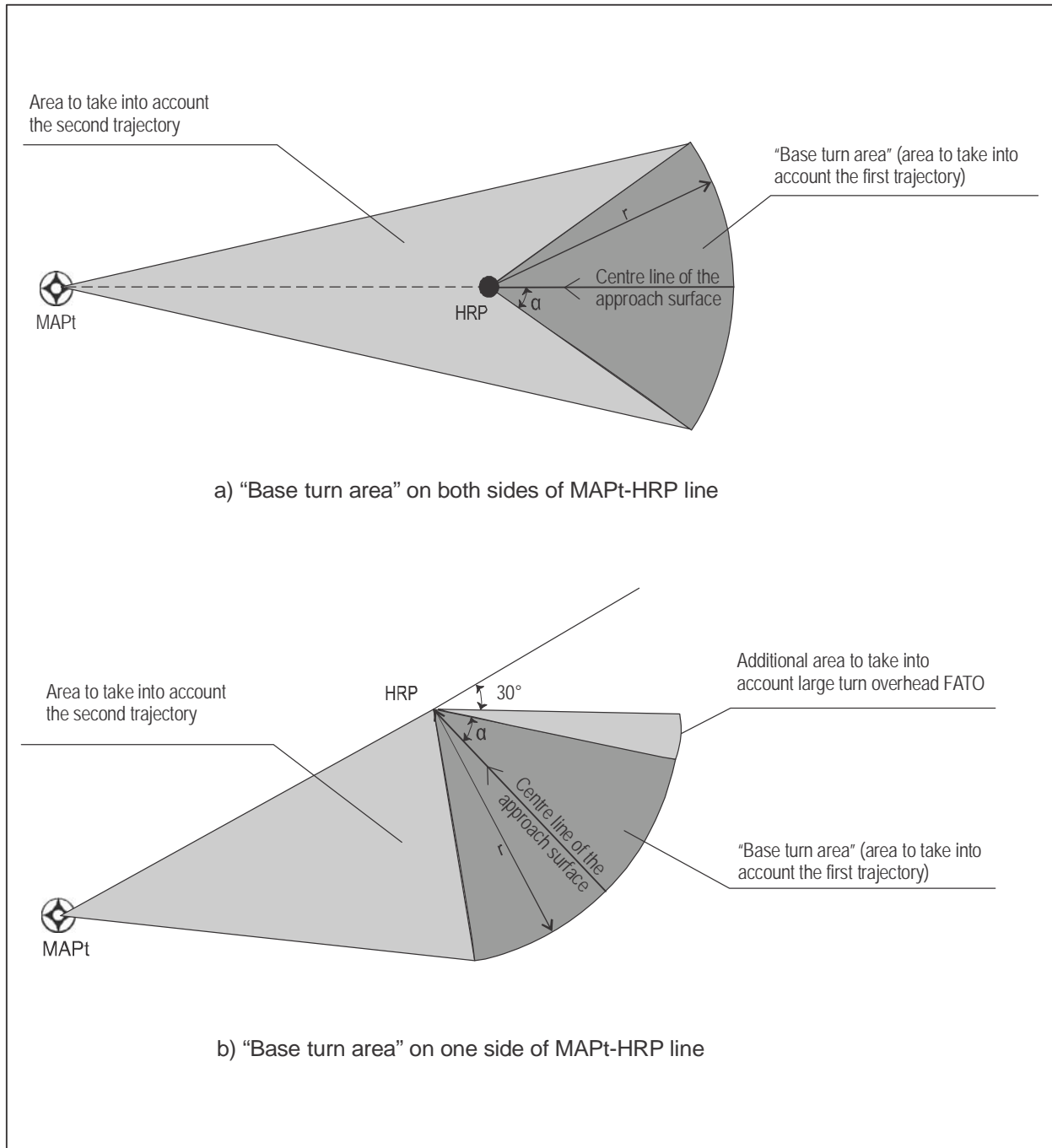

Figure IV-2-11. Different types of "Manoeuvring areas" depending on the defined approach surface

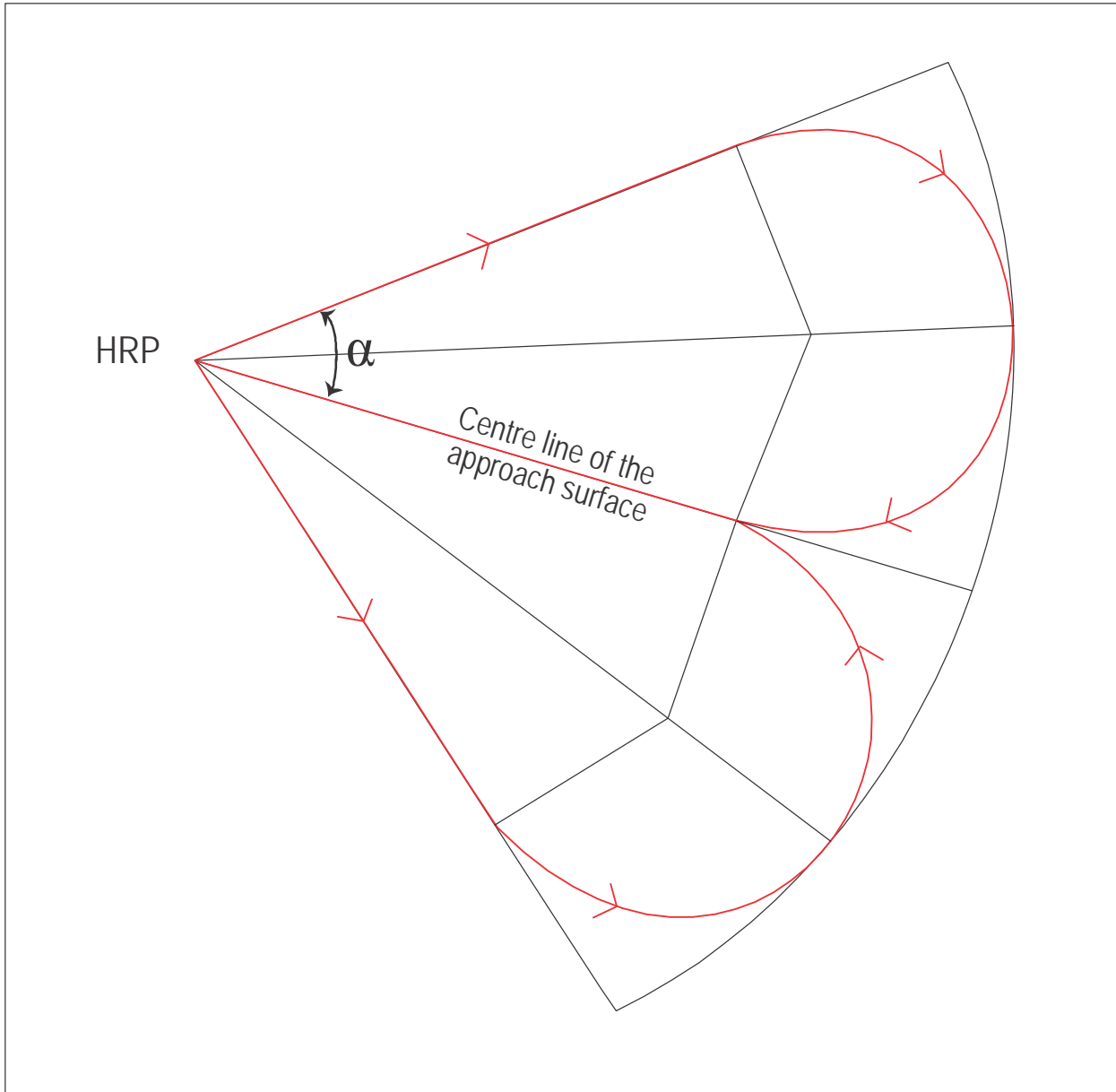

Figure IV-2-12. "Base turn area"

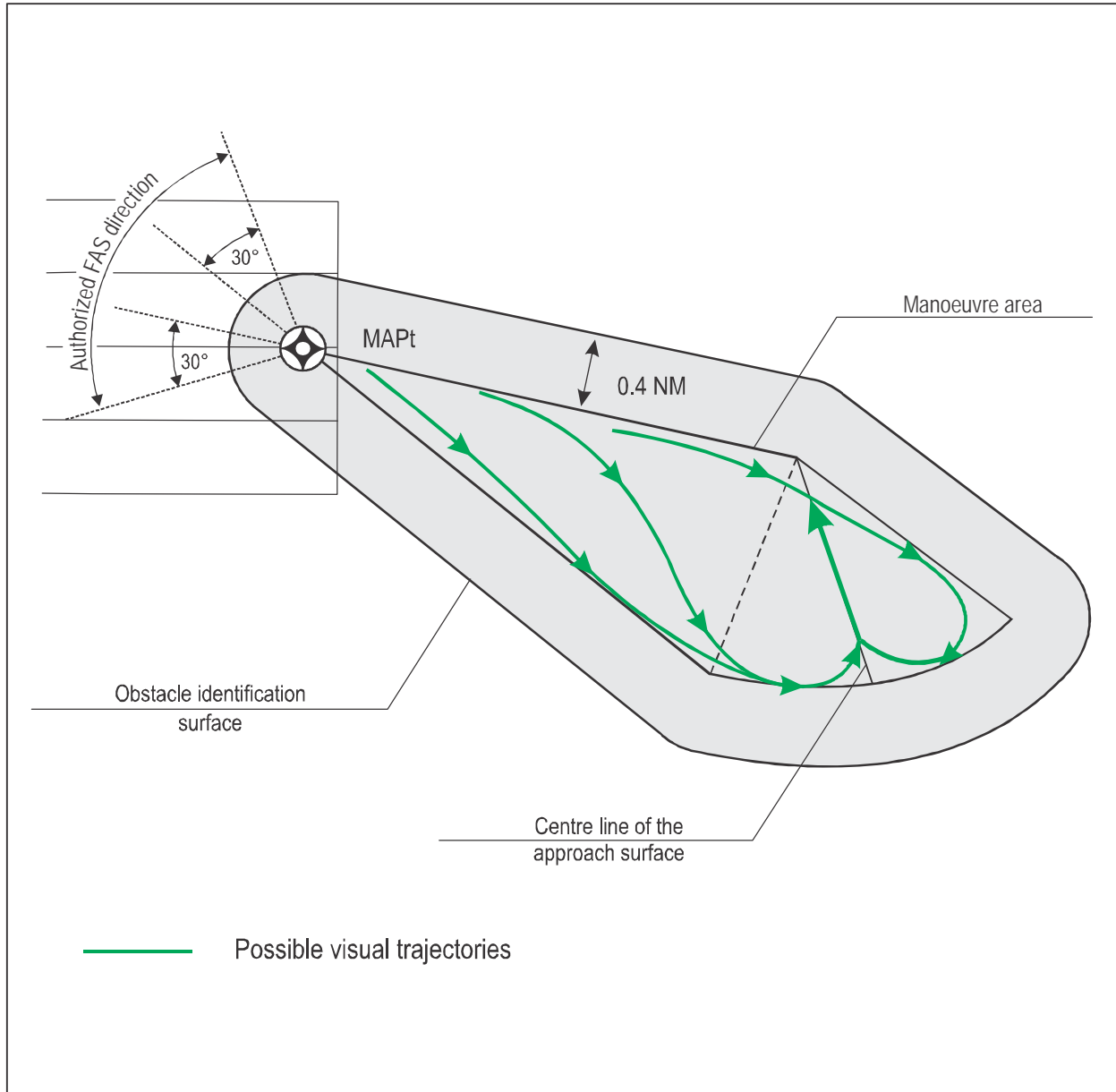

Figure IV-2-13. Representation of the level OIS for a defined approach surface

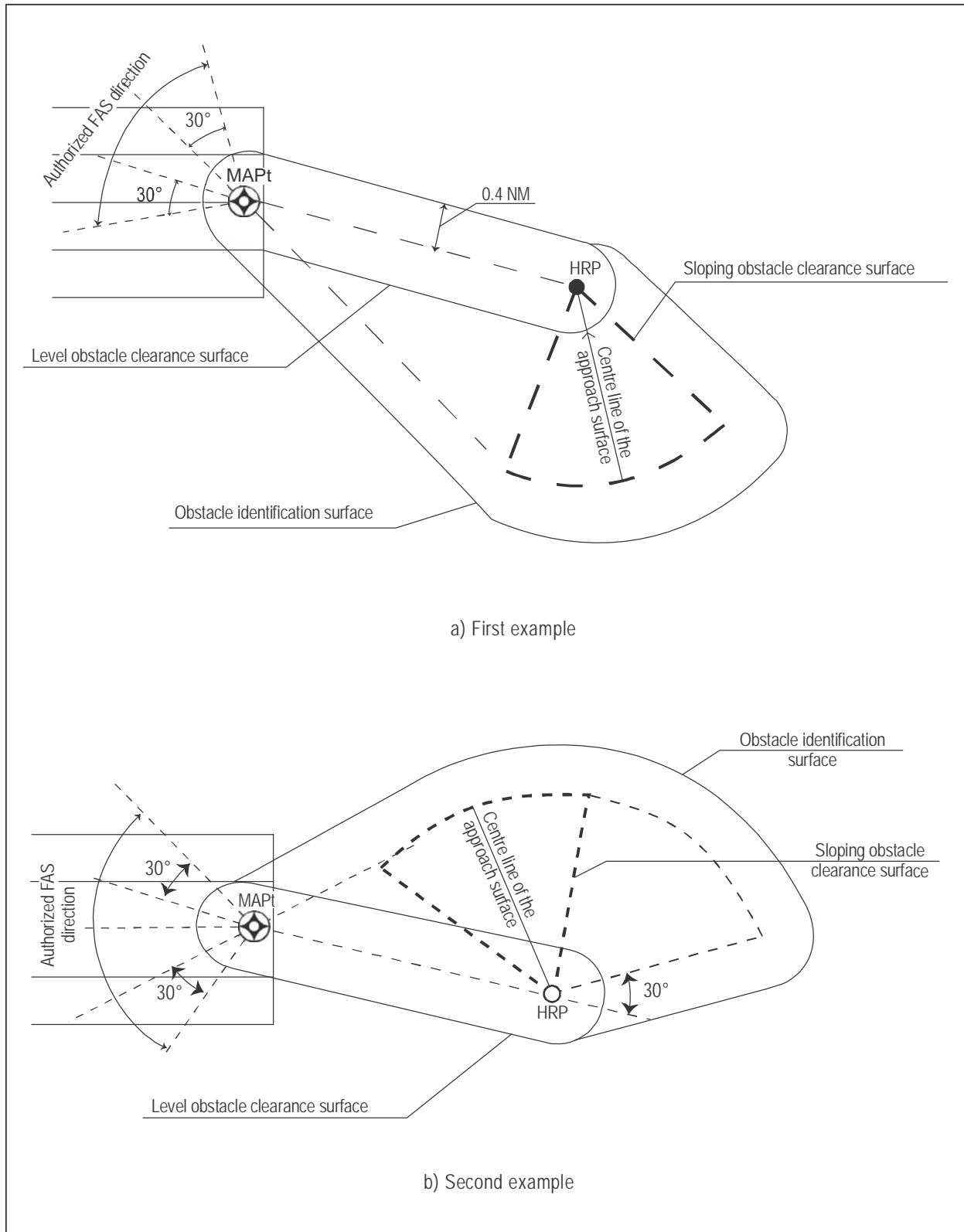

Figure IV-2-14. Representation of the level OIS and level OCS based on two different approach surfaces

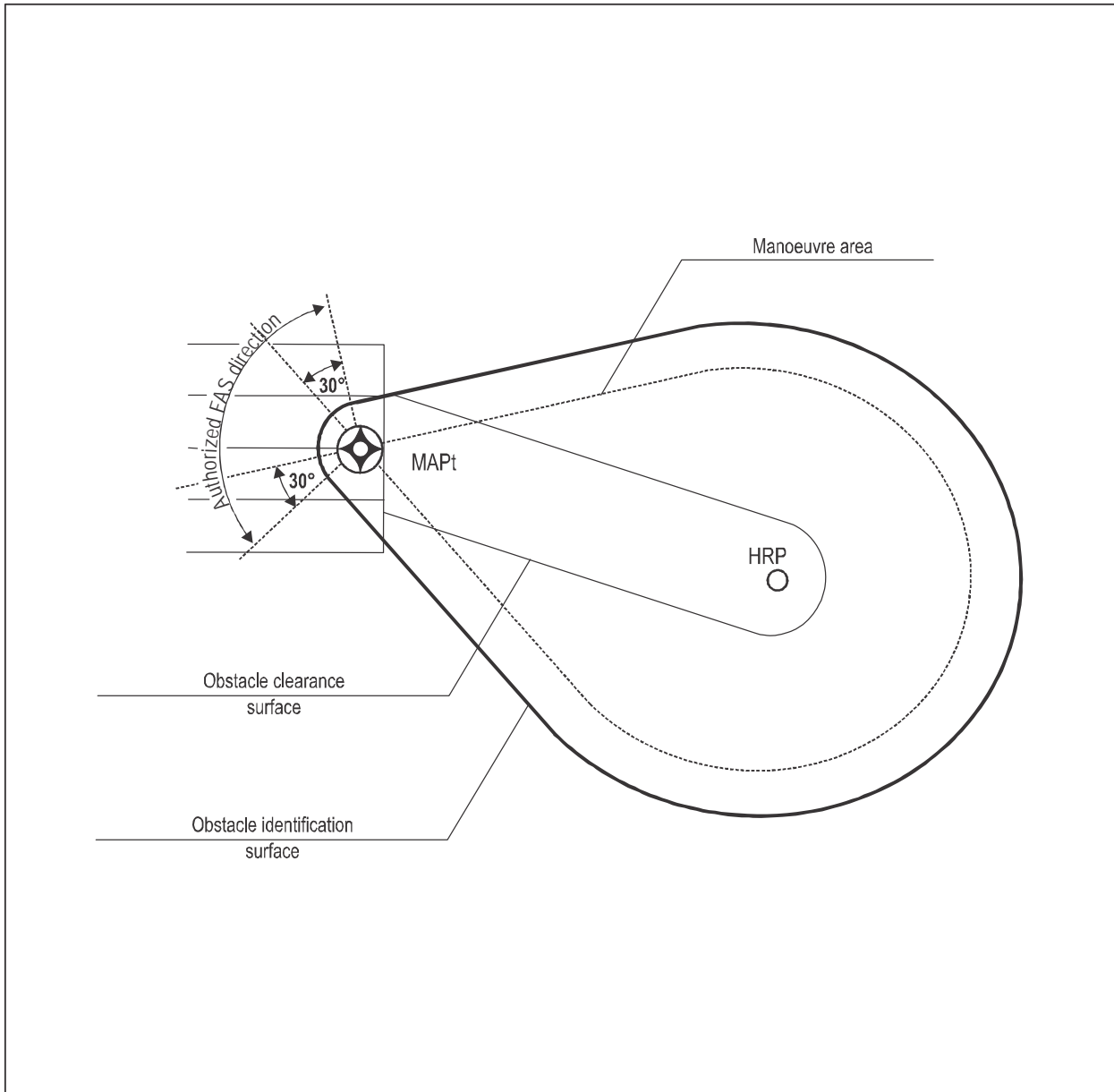

Figure IV-2-15. Representation of the level OIS and level OCS with “omni-directional” approach surfaces considered

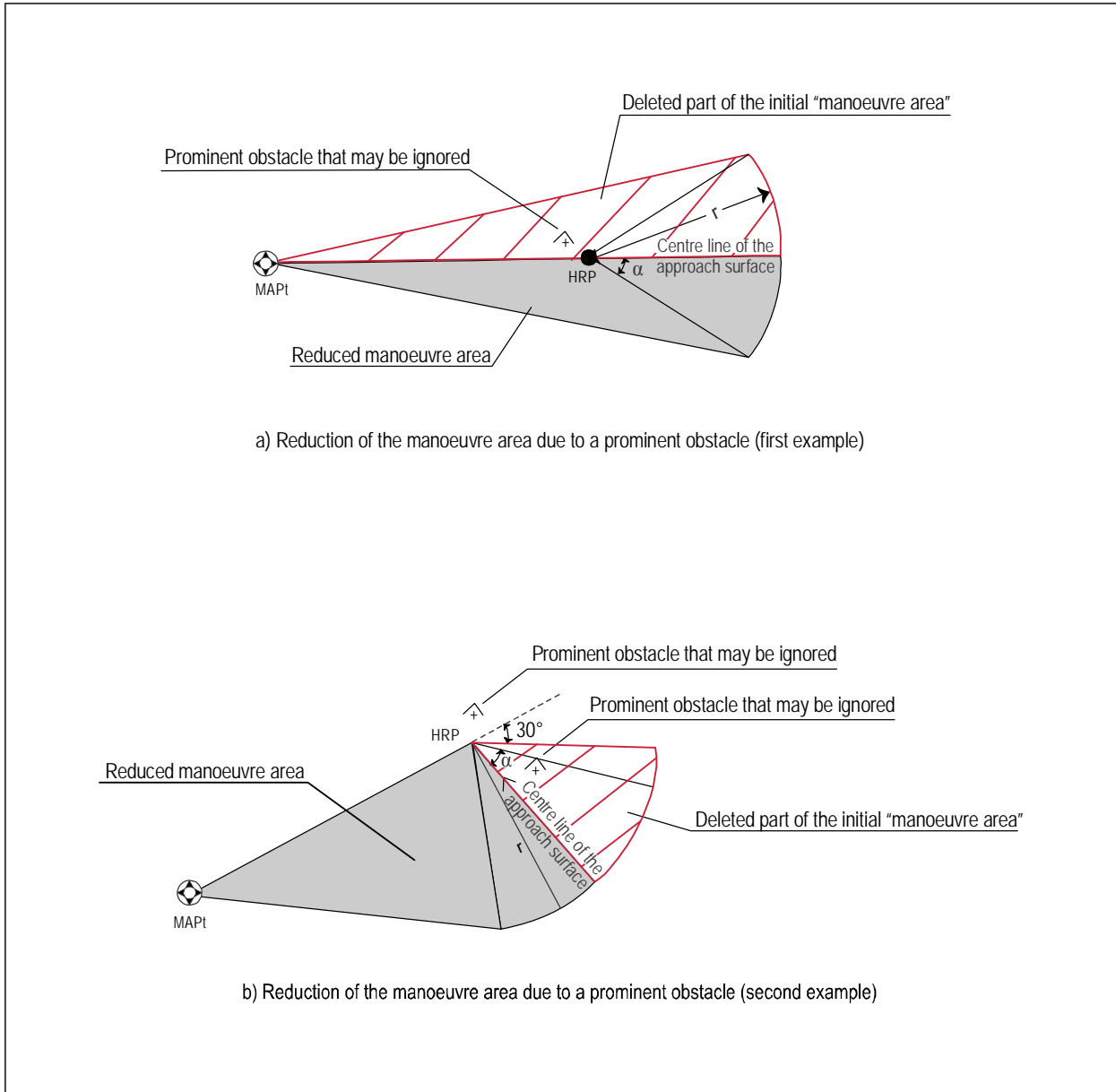

Figure IV-2-16. Method for reducing OCA/H: Reduction of the “Manoeuvring area”

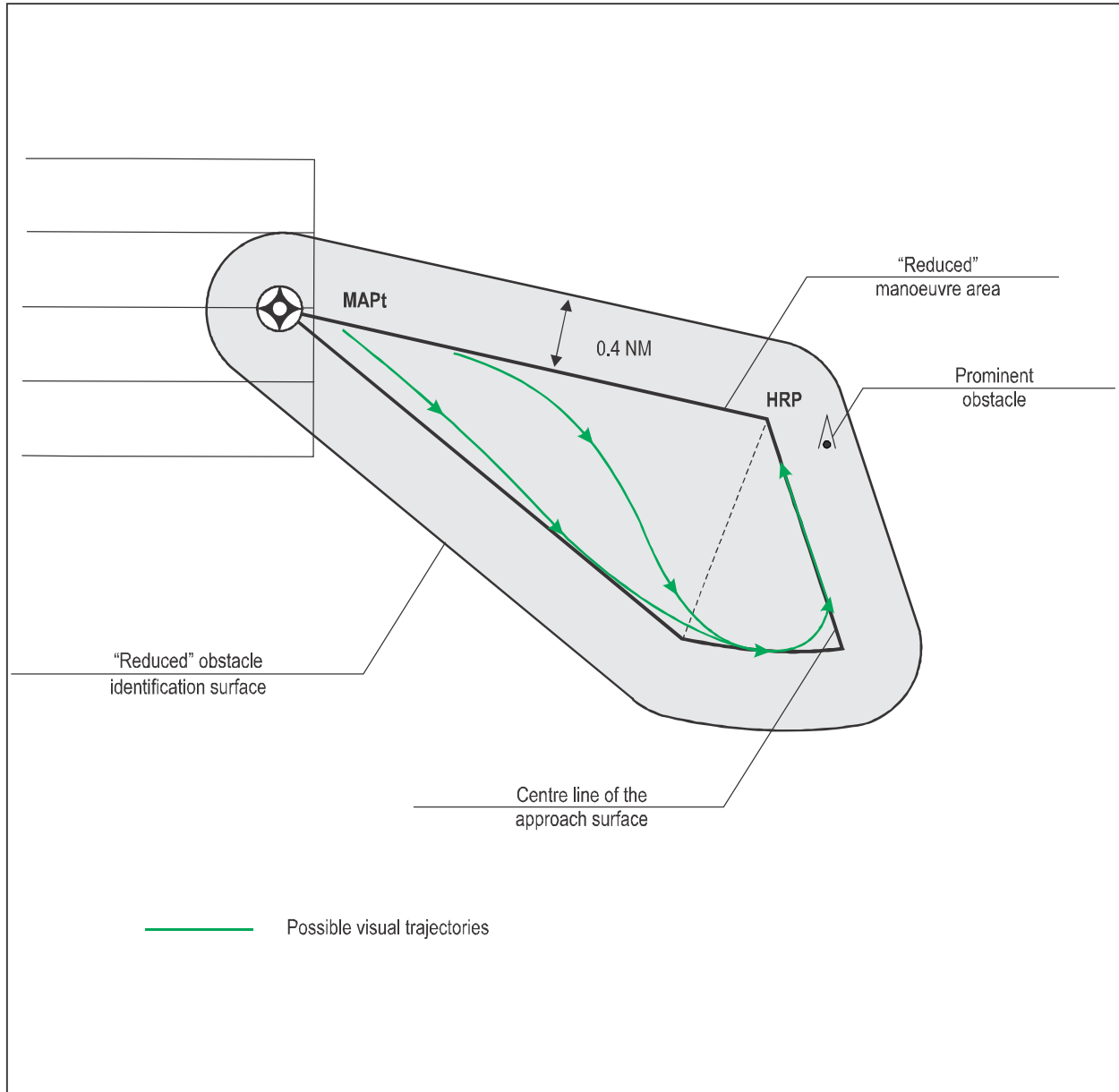

Figure IV-2-17. Method for reducing OCA/H: Reduced "Manoeuvring area" and level OIS

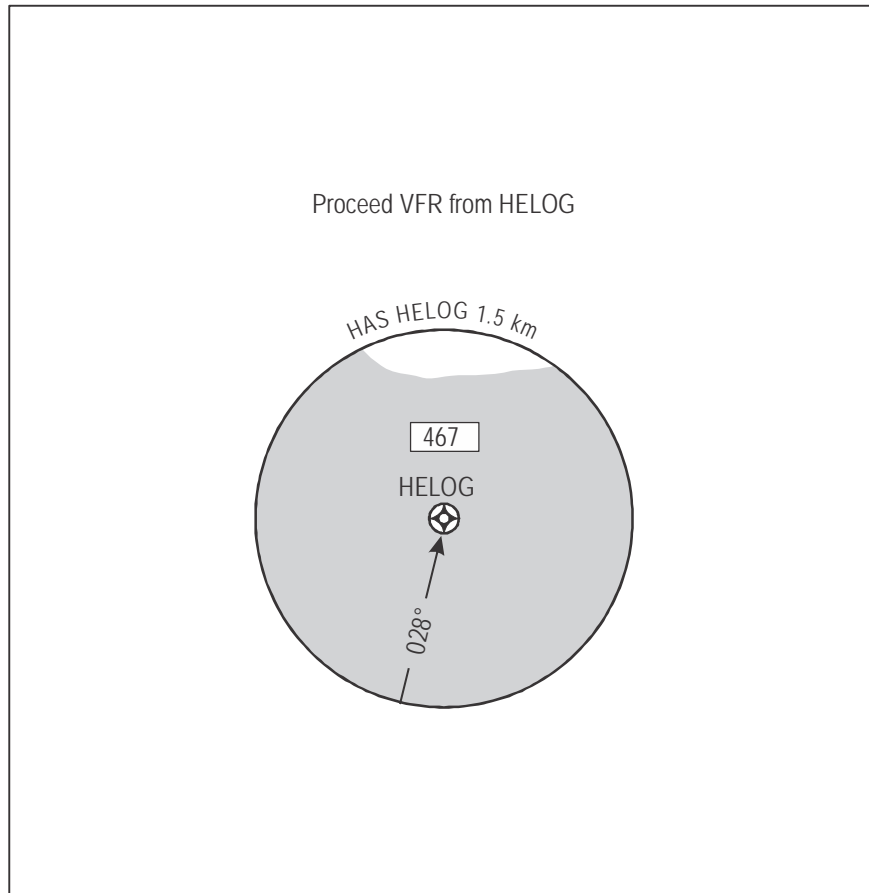

Figure IV-2-18. HAS diagram (showing both water and land surfaces) for PinS approach procedure with a “Proceed VFR” instruction

Chapter 3

POINT-IN-SPACE (PinS) RNP APCH APPROACH PROCEDURES FOR HELICOPTERS DOWN TO LPV MINIMA

3.1 GENERAL

The general criteria in Part III, Section 3, Chapter 5 and Part IV, Chapter 2, as amplified or modified by the criteria in this chapter, apply to PinS RNP APCH approaches for helicopters down to LPV minima.

3.2 FINAL APPROACH SEGMENT (FAS)

3.2.1 *FHP (fictitious heliport point) and PinS locations.* The final approach segment, ending at the PinS, is oriented on a FHP (fictitious heliport point). The FHP elevation is equal to the elevation of the landing heliport. The distance between the PinS and the FHP is equal to 800 m. This is illustrated in Figure IV-3-1 and Figure IV-3-App-1 in the Appendix.

3.2.2 *Definition of the FAS data block parameters.* Possible encoding for the FAS data block fields for PinS SBAS APV procedures is described in the Appendix. The following values are fixed:

- a) the distance between the GARP and the FHP is equal to 3 000 m;
- b) the FHP course width is equal to +/-105 m.

3.2.3 *Definition of an operational FAS.* Once the PinS and the FHP locations have been defined, an operational FAS can be defined. The following assumption is used: the OCA/H of the precision segment (OCA/Hps) is equal to the altitude/height of the nominal glide path at the PinS location. Based on this assumption, the operational FAS is defined by fixing two of the following three values: the Glide Path Angle (GPA), the OCA/Hps at the PinS and the crossing height of the flight path angle above the FHP (FHPCH). The following constraints apply for those values:

- a) $GPA \leq 6.3^\circ$ (11%);
- b) $OCHps \geq 250$ ft;
- c) $FHPCH \geq 0$.

Note 1.— Height values are above the heliport or landing location elevation.

Note 2.— Where the requirement that the FHP elevation be equal to the landing heliport elevation restricts the flexibility in design to an unacceptable level, another reference point may be used. Attention should be given to ensure that obstacles and OAS are based on the appropriate reference point.

3.2.4 *Validation of the chosen operational FAS.* Once the operational FAS has been defined, the general protection criteria described in Part III, Section 3, Chapter 5 shall be applied. The system of coordinates used to express protection surfaces shall be based on the FHP location. General protection criteria shall be applied using Cat H

parameters. However, because the OCA/Hps is geometrically fixed by the operational FAS, the following iterative process shall be performed to achieve the most efficient procedure, through application/determination of the lowest possible OCH and the lowest acceptable GPA:

- a) if there is no penetration of the protection surfaces by an obstacle leading to an OCA/H greater than the OCA/Hps, the defined operational FAS is acceptable. However, if the FAS is not the most efficient, a different FAS may be defined (for instance by decreasing the OCA/Hps and FAF elevation or by keeping the same FAF elevation and increasing the GP) and the obstacle protection surfaces shall be checked to determine whether lower minima can be achieved;
- b) if there is a penetration of the protection surfaces by an obstacle leading to an OCA/H greater than the OCA/Hps, the defined FAS is not acceptable. In this case, a new operational FAS shall be defined (for instance by increasing both the OCA/Hps and FAF elevation or by keeping the same FAF elevation and decreasing the GP) and the new protection surfaces shall be checked.

3.3 VISUAL SEGMENT: ADJUSTMENT OF THE OCA/H AND PROTECTION

3.3.1 *Adjustment of the OCA/H.* In order to ensure adequate transition between the instrument phase of flight and the visual phase of flight, the final OCA/H is calculated by including an “add-on” value to the OCA/Hps defined in paragraph 3.2.3 and 3.2.4. This “add-on” value is directly linked to the GPA and is calculated by using the following formula:

$$\text{“add-on” value (ft)} = (1\ 460/102) * \text{GPA (degree)}$$

The results of the calculation for a set of GPA values are detailed in Table IV-3-1.

Table IV-3-1. “Add-on” for a set of GPA values

<i>GPA</i>	<i>Add-on value (ft)</i>	<i>Add-on value (m)</i>
3°	43	13.1
3.5°	50	15.3
4°	57	17.5
5°	72	21.9
6°	86	26.2

3.3.2 *Protection of the visual segment.* Criteria used for the definition and the protection of the visual segment described in paragraph 2.9 apply. However, where the OCA/H is used for the design of the LNAV procedure, it shall be replaced by the OCA/Hps value defined in paragraph 3.2.4. Similarly, where MDA/H value is used in paragraph 2.9, it shall be replaced by the (DA/H – “add-on”) value.

3.4 SUPPORTING PinS RNP APCH WITH LNAV MINIMA

When LNAV and LPV minima for a PinS RNP APCH procedure are depicted on the same chart, the PinS and GPA of the two approaches shall be the same. The LNAV GPA shall equal the LPV GPA and shall not be calculated in accordance with paragraph 2.7.5. As per definition, the LPV OCA/Hps shall be reached at the PinS location, and the LNAV OCA/H shall be reached before the PinS.

3.5 MISSED APPROACH

The missed approach turn shall be prescribed at a designated turning point (TP) (see Part III, Section 3, Chapter 5).

Note.— Currently criteria for turns at a designated altitude/height or “as soon as practicable” are not defined but are under development. Such criteria may be necessary in some locations, due to specific obstacle limitations, to optimize the LPV minima.

3.6 PROMULGATION

3.6.1 PinS approaches to LPV minima shall be promulgated in accordance with Part III, Section 5, Chapter 1 and Part IV, Chapter 2, paragraph 2.11.

3.6.2 A vertical profile inset shall be charted for these procedures. Information depicted in the vertical profile inset shall include the:

- a) LNAV visual segment profile;
- b) APV visual segment profile;
- c) heliport or landing location;
- d) location of the MAPt;
- e) final portion of the LNAV final approach segment;
- f) final portion of the APV final approach segment;
- g) heliport elevation;
- h) HCH;
- i) range scale originating from the MAPt to the heliport, which is also used to identify the DP, if one exists in the visual segment;
- j) visual segment track; and
- k) necessary notes needed to highlight certain attributes of the visual segment profiles.

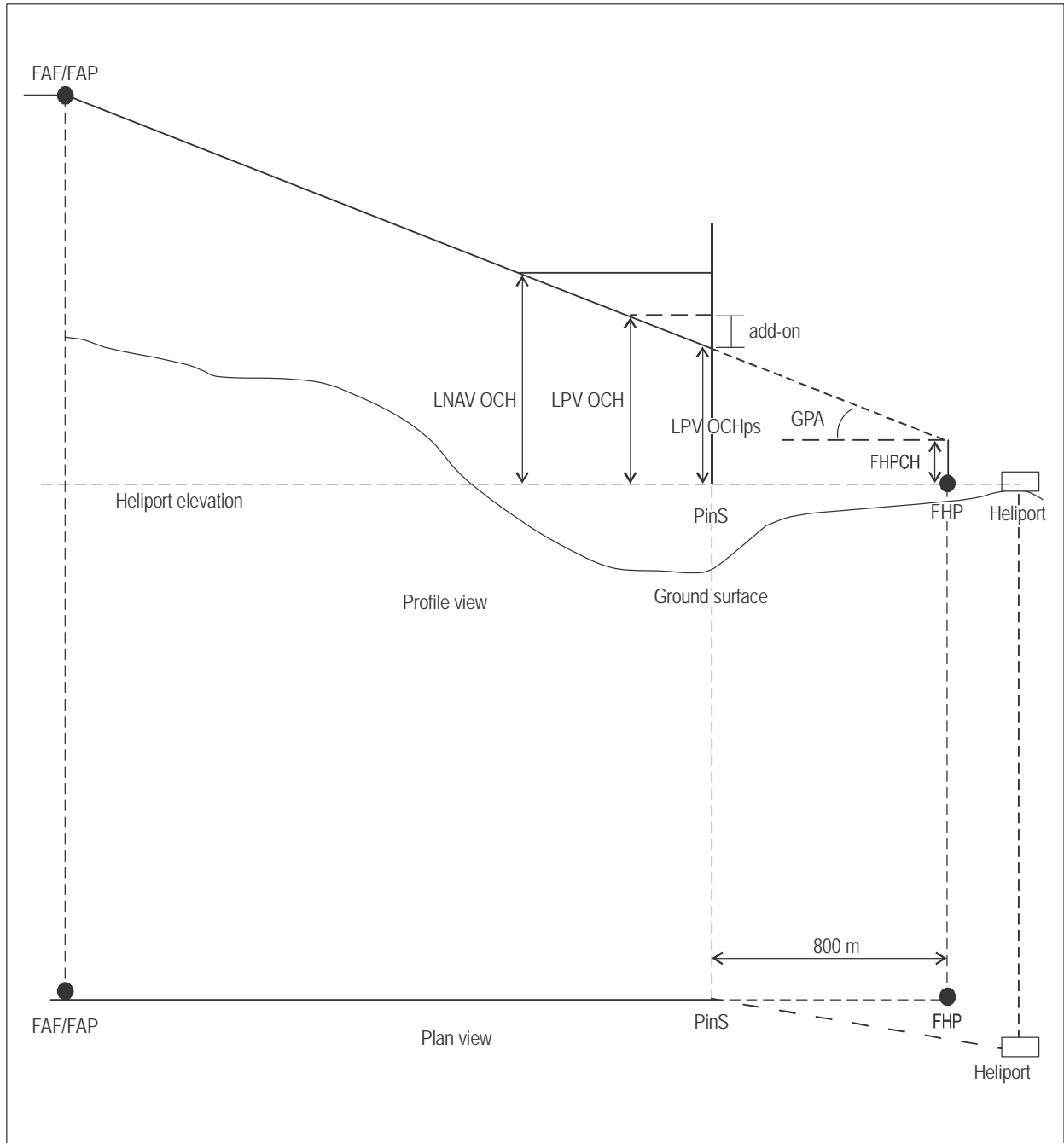

Figure IV-3-1. Representation of a PinS RNP APCH supporting LNAV and LPV minima

Appendix to Chapter 3

ENCODING OF THE SBAS HELICOPTER PinS FAS DATA BLOCK AND DISPLAY SCALING

1. **FAS Data Block Applications to PinS Procedures.** The encoding of the FAS data block fields for PinS operations is based on Part III, Section 2, Chapter 6, Appendix A and should be encoded as described below:

- a) *Operation type*: 0 is reserved for straight-in or PinS procedures.
- b) *Service provider identifier*: 0 for WAAS, 1 for EGNOS, 2 for MSAS 3 for GAGAN, 4 for SDCM. A service provider ID of 15 indicates that any service provider may be used and a service provider ID of 14 indicates the FAS data block is not intended for SBAS use.
- c) *Airport identifier*: If the heliport has an identifier, it is encoded. If the heliport does not have an identifier, the procedure MAPt waypoint name, truncated to a maximum of four characters, should be used, since it is the closest described point in the procedure database to the heliport. For procedures serving multiple heliports, the procedure MAPt waypoint name should be used.
- d) *Runway number*: Runway number is interpreted as the final approach course rounded to the nearest 10 degrees (2 digits). For final approach courses between 355° and 004°, the runway number field should be encoded to 36.
- e) *Runway letter*: Since there is not a letter associated with the procedure, the field is encoded as 00.
- f) *Approach performance designator*: The approach performance designator field is intended for the use by GBAS equipment and not used for SBAS operations.
- g) *Route indicator*: Encode the same as in Part III, Section 2, Chapter 6, Appendix A.
- h) *Reference path data selector (RPDS)*: A numerical identifier used to select the FAS data block (desired approach). It is intended for GBAS and is not used for SBAS operations.
- i) *Reference path identifier*: Since these procedures are not flown to runways, the two-digit runway number is replaced with the FAS track rounded to the closest 10 degrees. For FAS tracks 355° to 004°, the runway number portion of the field should be encoded to 36.

Note.— This coding is consistent with a PinS procedure that supports approaches to more than one landing site.

- j) *Landing threshold point (LTP)/fictitious threshold point (FTP)-latitude*: Encode the heliport/fictitious heliport point (HP/FHP) latitude the same as the LTP/FTP is encoded in Part III, Section 2, Chapter 6, Appendix A.
- k) *Landing threshold point (LTP)/fictitious threshold point (FTP)-longitude*: Encode the HP/FHP longitude the same as the LTP/FTP is encoded in Part III, Section 2, Chapter 6, Appendix A.
- l) *LTP/FTP height above ellipsoid (HAE)*: Encode the HP/FHP height above ellipsoid the same as the LTP/FTP HAE is encoded in Part III, Section 2, Chapter 6, Appendix A.

- m) *Δ flight path alignment point (FPAP)-latitude*: This is the Δ latitude of a point located on a geodesic line beyond the HP/FHP that is aligned with the PinS FAS. Encode the same as in Part III, Section 2, Chapter 6, Appendix A.
- n) *Δ flight path alignment point (FPAP)-longitude*: This is the Δ longitude of a point located on a geodesic line beyond the HP/FHP that is aligned with the PinS FAS. Encode the same as in Part III, Section 2, Chapter 6, Appendix A.
- o) *Threshold crossing height (TCH)*: The designated crossing height of the flight path angle above the heliport/fictitious heliport point crossing height (FHPCH). Encode the same as in Part III, Section 2, Chapter 6, Appendix A.
- p) *TCH units selector*: Encode the same as depicted in Part III, Section 2, Chapter 6, Appendix A.
- q) *Glidepath angle*: Encode the same as shown in Part III, Section 2, Chapter 6, Appendix A.
- r) *Course width at threshold*: This is replaced with the course width at the heliport/fictitious heliport. For SBAS APV PinS approaches, the FHP course width is equal to ± 105 m.
- s) *Δ length offset*: Since there is not a runway associated with the procedure, the field is encoded with a 0.
- t) *Horizontal alert limit (HAL)*: Encode as shown in Part III, Section 2, Chapter 6, Appendix A. PinS procedures have $HAL = 40$.
- u) *Vertical alert limit (VAL)*: For PinS procedures with lateral only guidance, $VAL = 0$. When vertical guidance is provided, $VAL \leq 50$.
- v) *Final approach segment CRC remainder*: Calculate and encode as shown in Part III, Section 2, Chapter 6, Appendix A.

2. **Display Scaling and Fictitious Heliport Orientation.** Figure IV-3-App-1 depicts the fictitious heliport orientation and display scaling that flight testing has demonstrated to be satisfactory. At the FHP, the lateral course width is ± 105 m. With the 3 000 m distance between the FHP and GARP, the resulting angular splay is 2° . Extensive flight testing has demonstrated the best combination of procedure flyability and obstacle protection requirements results in a distance of 800 m between the PinS/MAPt and the FHP with a lateral course width of ± 133 m at the PinS/MAPt location. The extreme flexibility in the application of the FAS data block to PinS procedures is noted.

3. Figure IV-3-App-2 depicts the vertical display scaling and the scaling relationship to the fictitious heliport. Vertical display scaling includes the option of linear scaling once angular scaling becomes greater than ± 150 m or smaller than 15 m. The location along the vertical path where the optional linearization of display begins is a function of the glidepath angle angular splay ($\text{glidepath angle}/4^\circ$) where the full scale width is less than or equal to ± 15 m, or greater than or equal to 150 m. The FHP and the glide path intercept point (GPIP) lay in the same plane. The horizontal distance from the FHP to the PinS/MAPt location is maintained at 800 m regardless of the glide path angle to provide for proper lateral display scaling requirements.

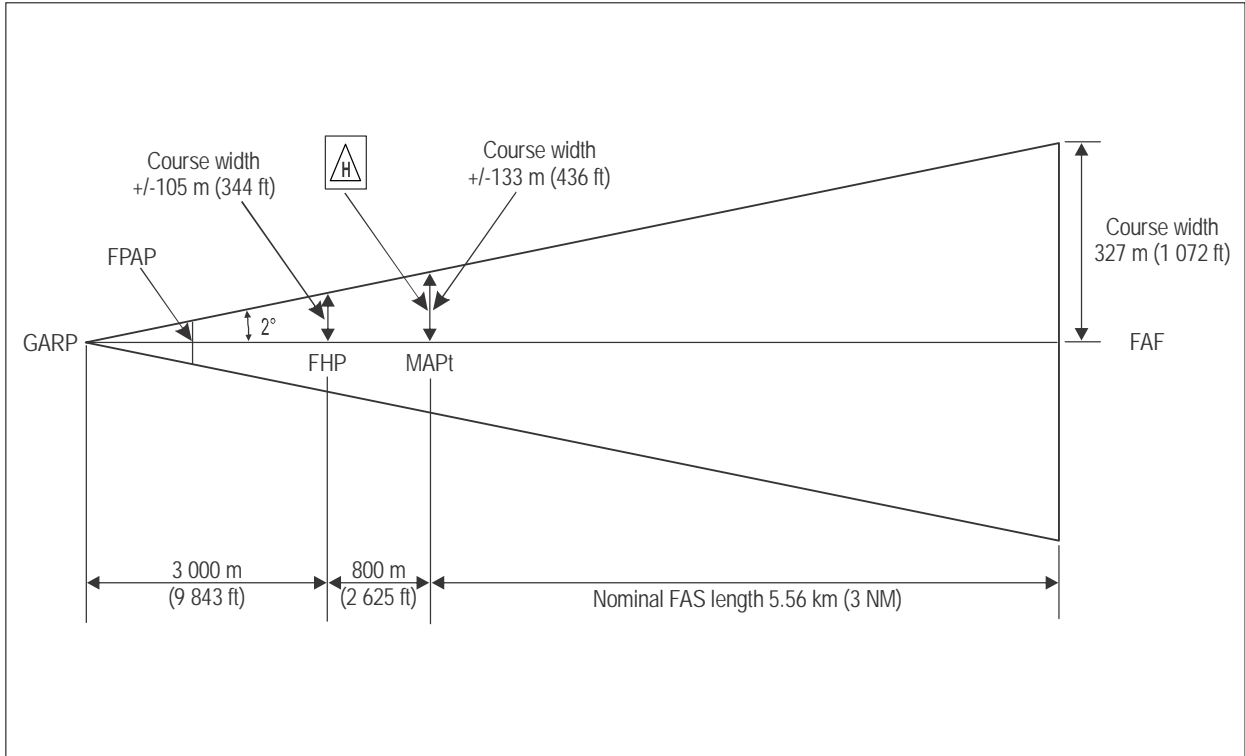

Figure IV-3-App-1. Fictitious heliport orientation and lateral display scaling

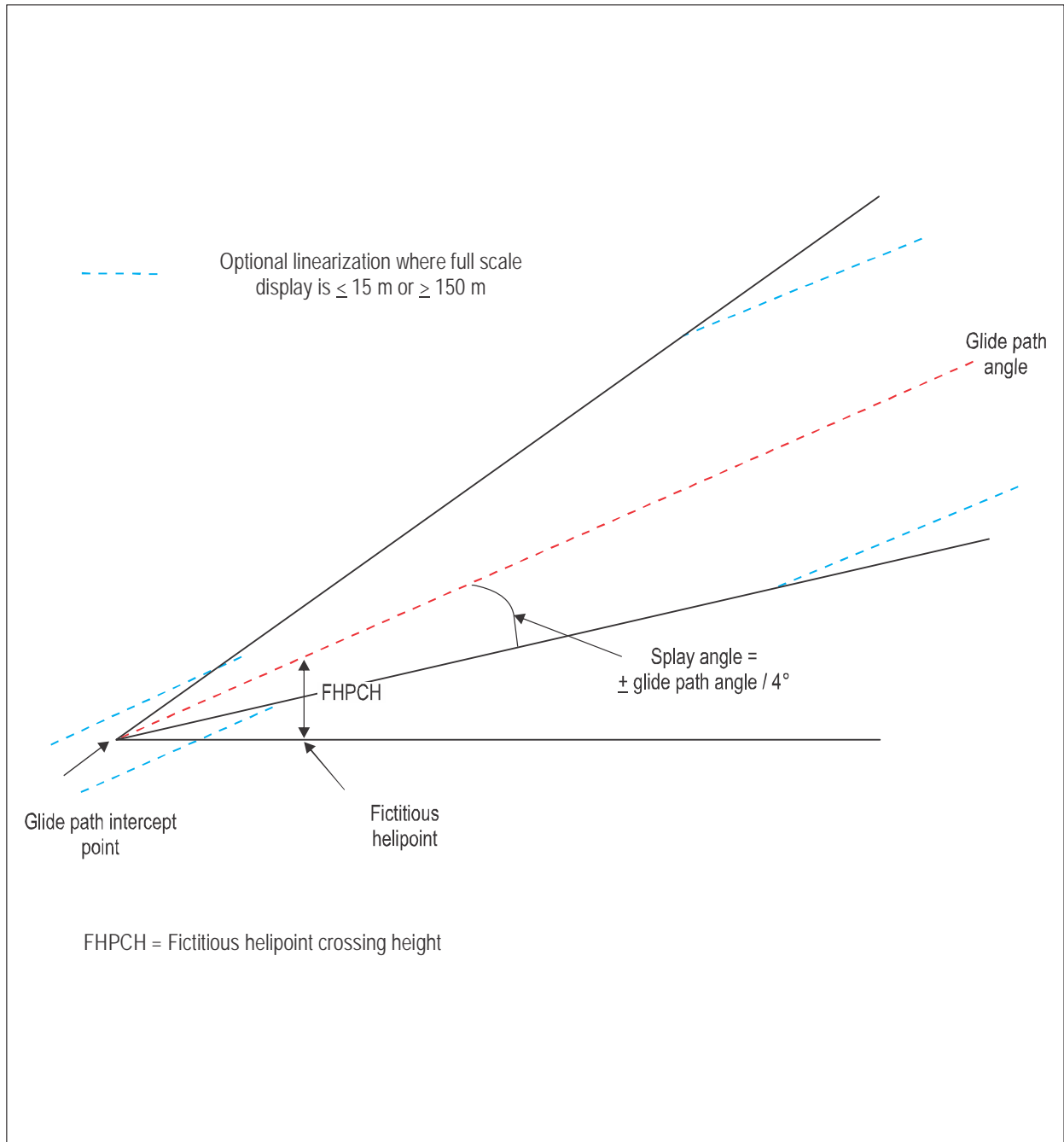

Figure IV-3-App-2. Fictitious heliport orientation and vertical display scaling

— END —

