



4

## Index

### Series 41

	<b>Description</b>	<b>Page 61</b>
	<b>Product Assembly</b>	<b>Page 62</b>
	<b>Product Range</b>	
	- pushbuttons for standard mounting	<b>Page 63</b>
	- accessories / spare parts	<b>Page 65</b>
	<b>Technical Data</b>	<b>Page 70</b>
	<b>Technical Drawing / Dimension / Layout</b>	<b>Page 72</b>
	<b>Circuit Drawing</b>	<b>Page 74</b>
	<b>Marking</b>	<b>Page 75</b>

## General Notes

Series 41 consist of illuminated pushbuttons and indicators with two indicator lamps.  
 The twin-lamp system makes the following methods of indication possible:

- indication of two independent functions
- indication in two colours for different functions
- enhanced reliability of indication with two lamps

With two-coloured lenses the illuminated areas are separated by an opaque barrier.  
 The switches can be supplied with snap-action or low-level switching elements.  
 The front dimensions of these units are 18 x 24 mm.

## Mounting

Mount from the front through the mounting hole.  
 Plug-in mounting: The switch is simply pushed into the opening in the panel. The clips snap on to the front plate of the panel. No tools are needed.  
 The universal terminals of the low-level switching elements permit mounting on printed circuit boards (PCB).  
 These terminals are also suitable for dip soldering. For these terminals we can also supply a plug-in base which, when soldered on to the board, enables the switch to be plugged in.

## Lenses

The flat monocolour or two-colour lenses with separating barrier, made of polycarbonate, are obtainable in various colours, or in a transparent version.  
 The extended sides of the bezel prevent unintentional actuation.

## Marking

For engravings, hot stamping and film inserts, see under "Marking" on page 75.

## Illumination

Perfect illumination of the different coloured lenses is assured by mid-grooved lamps T 1 3/4 (6-40 V).  
 For supply voltages above 60 V, it is necessary to use a voltage reduction element (external series resistor, capacitor or transformer).  
 Do not solder the terminals directly, because of the high surface temperature.  
 Multi-LED mid-grooved lamps T 1 3/4 (6, 12, 24, 48 V) are available in the colours, white, red, yellow and green.

## Position Indication

When a switch with maintained action is actuated, the lens remains in the depressed position mechanically. The state of the switch is apparent at all times from the position of the lens.

*All dimensions in mm.  
 We reserve the right to modify technical data.*

## Number structure

41-XXX.OXX

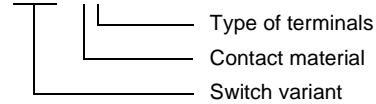

Example:

-Illuminated pushbutton with momentary action; gold-plated silver contact; 1 switching element  
 41-121.025  
 -Lens, red/green, translucent support  
 41-907.2/5

## Specimen order

### Indicator

- indicator, soldering terminal	41-040.005
<u>Recommended accessories:</u>	
- lens, one-colour, blue	41-903.6
- LED, 1 chip, white	10-2312.3139

## illuminated-/pushbutton

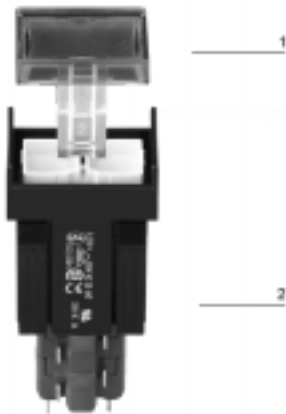

- 1 lens
- 2 switch housing

## indicator



### recommended accessories:

🛒 lens of one colour → 65; lens of two colours → 65

🛒 incandescent lamp → 67; LED → 67

	connection method	18 x 24 mm part no.	circuit drawing	technical drawing	mounting dimension	
<b>indicator</b> with two independent lamp bases	ST	<b>41-040.005</b>	1	1	1	0,009
	UT	<b>41-041.006</b>	1	2	1	0,009

connection method: ST = soldering terminal; UT = universal terminal; PCB plug-in base page 66

marking see page 75

technical drawing as of page 72, mounting dimensions as of page 73, circuit drawing as of page 74

## illuminated-/pushbutton



### recommended accessories:

🛒 lens of one colour → 65; lens of two colours → 65

🛒 incandescent lamp → 67; LED → 67

	switching system	contacts	switching action	connection method	18 x 24 mm part no.	circuit drawing	technical drawing	mounting dimension		
<b>illuminated-/pushbutton</b> with two independent lamp bases	LL	1NC + 1NO	main	UT	<b>41-463.036</b>	7	2	1	0,014	
			mom	UT	<b>41-423.036</b>	14	2	1	0,014	
		2NC	main	UT	<b>41-462.036</b>	6	2	1	0,014	
			mom	UT	<b>41-422.036</b>	13	2	1	0,014	
		2NO	main	UT	<b>41-461.036</b>	8	2	1	0,014	
			mom	UT	<b>41-421.036</b>	15	2	1	0,014	
		SA	1NC + 1NO	main	ST	<b>41-261.025</b>	5	3	1	0,011
				mom	ST	<b>41-121.025</b>	12	3	1	0,011
	2NC + 2NO		main	ST	<b>41-262.025</b>	4	3	1	0,013	
			mom	ST	<b>41-122.025</b>	11	3	1	0,012	
	3NC + 3NO		main	ST	<b>41-263.025</b>	3	3	1	0,014	
			mom	ST	<b>41-123.025</b>	10	3	1	0,014	
	4NC + 4NO	main	ST	<b>41-264.025</b>	2	3	1	0,015		
		mom	ST	<b>41-124.025</b>	9	3	1	0,015		

switching system: LL = Low Level switching element, SA = snap-action switching element

switching action: main = maintained action, mom = momentary action

connection method: ST = soldering terminal; UT = universal terminal; PCB plug-in base page 66

contacts: NC = normally closed, NO = normally open



power rating: Low Level switching element: 42 V/100 mA, snap-action switching element: 250 V/5 A

marking see page 75



technical drawing as of page 72, mounting dimensions as of page 73, circuit drawing as of page 74

## at front



### lens of one colour

	shape	lens/support	colour	 18 x 24 mm part no.		
<b>lens of one colour</b> for film insert with restrictions	flat	transparent/transparent	colourless, clear	<b>41-904.7</b>	0,001	
			green	<b>41-904.5</b>	0,001	
			orange	<b>41-904.3</b>	0,001	
			red	<b>41-904.2</b>	0,001	
			yellow	<b>41-904.4</b>	0,001	
of plastic	flat	transparent/translucent	blue	<b>41-903.6</b>	0,001	
			colourless, clear	<b>41-903.7</b>	0,001	
			green	<b>41-903.5</b>	0,001	
			orange	<b>41-903.3</b>	0,001	
			red	<b>41-903.2</b>	0,001	
			yellow	<b>41-903.4</b>	0,001	

### lens of two colours



	shape	lens/support	colour	 18 x 24 mm part no.		
<b>lens of two colours</b> of plastic with light barrier	flat	transparent/translucent	blue/colourless, clear	<b>41-907.6/7</b>	0,002	
			colourless, clear/colourless, clear	<b>41-907.7/7</b>	0,002	
			green/blue	<b>41-907.5/6</b>	0,002	
			green/colourless, clear	<b>41-907.5/7</b>	0,002	
			orange/blue	<b>41-907.3/6</b>	0,002	
			orange/colourless, clear	<b>41-907.3/7</b>	0,002	
			orange/green	<b>41-907.3/5</b>	0,002	
			orange/yellow	<b>41-907.3/4</b>	0,002	
			red/blue	<b>41-907.2/6</b>	0,002	
			red/colourless, clear	<b>41-907.2/7</b>	0,002	
			red/green	<b>41-907.2/5</b>	0,002	
			red/orange	<b>41-907.2/3</b>	0,002	
			red/yellow	<b>41-907.2/4</b>	0,002	
			yellow/blue	<b>41-907.4/6</b>	0,002	
			yellow/colourless, clear	<b>41-907.4/7</b>	0,002	
yellow/green	<b>41-907.4/5</b>	0,002				
with light barrier (not recommended for film insert)	flat	transparent/transparent	colourless, clear/colourless, clear	<b>41-908.7/7</b>	0,002	
			green/colourless, clear	<b>41-908.5/7</b>	0,002	
			orange/colourless, clear	<b>41-908.3/7</b>	0,002	
			orange/green	<b>41-908.3/5</b>	0,002	
			orange/yellow	<b>41-908.3/4</b>	0,002	
			red/colourless, clear	<b>41-908.2/7</b>	0,002	
			red/green	<b>41-908.2/5</b>	0,002	
			red/orange	<b>41-908.2/3</b>	0,002	
			red/yellow	<b>41-908.2/4</b>	0,002	
yellow/colourless, clear	<b>41-908.4/7</b>	0,002				
yellow/green	<b>41-908.4/5</b>	0,002				

## protective cover

			18 x 24 mm part no.	technical drawing		
<b>protective cover</b> hinged, transparent, cover to prevent accidental operations.			<b>41-925</b>	4	0,002	

[technical drawing as of page 72](#)



## blind plug

			18 x 24 mm part no.	mounting dimension		
<b>blind plug</b>	colour black		<b>41-947.0</b>	1	0,002	

[mounting dimensions as of page 73](#)



## at back

### PCB plug-in base



	for	pin orientation	part no.	components layout		
<b>PCB plug-in base</b> 18 x 24 x10 mm high	Low Level switching element	axial	<b>41-940</b>	1	0,004	

[components layouts as of page 73](#)

### cable shoe

		connection method	part no.			
<b>cable shoe</b> for Low Level switching element 2.0 mm		universal terminal 2,0 x 0,5 mm	<b>31-945</b>	0,001		

### insulation socket

			part no.			
<b>insulation socket</b> for connector 31-945			<b>31-928</b>	0,001		



## for illumination

### incandescent lamp

order 2 pcs. per switch



	voltage/current	part no.	
<b>incandescent lamp</b> base T 1 3/4 MG	6 AC/DC/125 mA	<b>10-1306.1349 (41-963.0)</b>	0,001
	12 AC/DC/75 mA	<b>10-1309.1309 (41-963.1)</b>	0,001
	18 AC/DC/40 mA	<b>10-1311.1249 (41-963.2)</b>	0,001
	24 AC/DC/35 mA	<b>10-1312.1229 (41-963.3)</b>	0,001
	28 AC/DC/30 mA	<b>10-1313.1209 (41-963.4)</b>	0,001
	36 AC/DC/20 mA	<b>10-1316.1179 (41-963.36)</b>	0,001
	48 AC/DC/20 mA	<b>10-1319.1179 (41-963.5)</b>	0,001



### LED

order 2 pcs. per switch

	number of chips	voltage/current	colour	part no.	
<b>LED</b> base T 1 3/4 MG	1 chip	24 VDC/14 mA	white	<b>10-2312.3139</b>	0,001
		28 VDC/14 mA	white	<b>10-2313.3139</b>	0,001
	6 chips	6 VDC/45 mA	green	<b>10-5306.3255 (31-968.05)</b>	0,001
			red	<b>10-5306.3252 (31-968.02)</b>	0,001
			yellow	<b>10-5306.3254 (31-968.04)</b>	0,001
		12 VDC/30 mA	green	<b>10-5309.3205 (31-968.15)</b>	0,001
			red	<b>10-5309.3202 (31-968.12)</b>	0,001
			yellow	<b>10-5309.3204 (31-968.14)</b>	0,001
		24 VAC/DC/12.5 mA	green	<b>10-5312.1115</b>	0,001
			red	<b>10-5312.1112</b>	0,001
			yellow	<b>10-5312.1114</b>	0,001
		24 VDC/14 mA	green	<b>10-5312.3135 (31-968.25)</b>	0,001
			red	<b>10-5312.3132 (31-968.22)</b>	0,001
			yellow	<b>10-5312.3134 (31-968.24)</b>	0,001
		28 VAC/DC/12.5 mA	green	<b>10-5313.1115</b>	0,001
			red	<b>10-5313.1112</b>	0,001
			yellow	<b>10-5313.1114</b>	0,001
		28 VDC/14 mA	green	<b>10-5313.3135</b>	0,001
			red	<b>10-5313.3132</b>	0,001
			yellow	<b>10-5313.3134</b>	0,001
	48 VDC/12 mA	green	<b>10-5319.3105 (31-968.45)</b>	0,001	
		red	<b>10-5319.3102 (31-968.42)</b>	0,001	
		yellow	<b>10-5319.3104 (31-968.44)</b>	0,001	
	8 chips	6 VDC/48 mA	green	<b>10-6303.3265</b>	0,001
			red	<b>10-6306.3262</b>	0,001
			yellow	<b>10-6306.3264</b>	0,001
		12 VDC/24 mA	green	<b>10-6309.3185</b>	0,001
			red	<b>10-6309.3182</b>	0,001
			yellow	<b>10-6309.3184</b>	0,001
		24 VDC/12 mA	green	<b>10-6312.3105</b>	0,001
			red	<b>10-6312.3102</b>	0,001
			yellow	<b>10-6312.3104</b>	0,001
		28 VDC/12 mA	green	<b>10-6313.3105</b>	0,001
			red	<b>10-6313.3102</b>	0,001
			yellow	<b>10-6313.3104</b>	0,001

## capacitor

for lamp voltage reduction

	value	part no.		
<b>capacitor</b> use with 48 VAC/20 mA, 50 Hz lamp voltage	230 VAC/0.27 $\mu$ F	<b>02-917.0</b>	0,004	

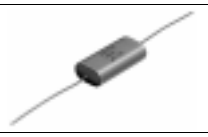
Wire in accordance with local electrical safety regulations.

## series resistor

for lamp voltage reduction

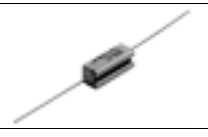
	value	part no.		
<b>series resistor</b> use with 48 VAC/20 mA lamp rating	110-125 V/3.9 kOhm	<b>02-904.2</b>	0,003	



Wire in accordance with local electrical safety regulations.

## terminal plate empty

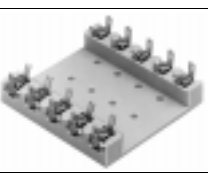
for fitting with series resistors and capacitors



	no. of spaces	part no.		
<b>terminal plate empty</b>	5 spaces	<b>02-912.1</b>	0,025	
	10 spaces	<b>02-912.2</b>	0,045	
	15 spaces	<b>02-912.3</b>	0,090	
	20 spaces	<b>02-912.4</b>	0,095	

## terminal plate with capacitor

	value	no. of components	part no.		
<b>terminal plate with capacitor</b> use with 60 VAC/20 mA lamp rating	0,27 $\mu$ F 230 VAC/48 V	5 spaces	<b>02-914.10</b>	0,135	
		10 spaces	<b>02-913.20</b>	0,155	
		15 spaces	<b>02-914.30</b>	0,045	
		20 spaces	<b>02-914.40</b>	0,090	

Wire in accordance with local electrical safety regulations.



## terminal plate with series resistor

	value	no. of components	part no.		
<b>terminal plate with series resistor</b> use with 60 VAC/20 mA lamp rating	3.9 kOhm/110-125/48 V	5 spaces	<b>02-913.12</b>	0,040	
		10 spaces	<b>02-913.22</b>	0,075	
		15 spaces	<b>02-913.32</b>	0,115	
		20 spaces	<b>02-913.42</b>	0,155	
	9.1 kOhm/230/48 V	5 spaces	<b>02-913.19</b>	0,115	
		10 spaces	<b>02-913.29</b>	0,155	
		15 spaces	<b>02-913.39</b>	0,040	
		20 spaces	<b>02-913.49</b>	0,075	



Wire in accordance with local electrical safety regulations.

## assembling

### lens remover

	part no.	 kg	
lens remover	<b>02-905</b>	0,011	

### lamp/LED remover

	part no.	 kg	
lamp/LED remover	<b>61-9740.0</b>	0,003	

### dismantling tool

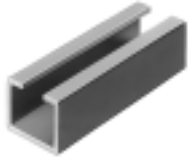
	part no.	 kg	
dismantling tool	<b>41-939</b>	0,027	

# Technical Data

## actuator with snap-action switching element

### switching system

Self-cleaning, double-break, snap action switching system. (with contact gap 2 x 0.5 mm).  
1 normally closed or 1 normally open contact per element.  
Up to 4 switching elements can be on a pushbutton (max. 4 normally closed and 4 normally open contacts).

### material

#### actuator case

polysulfone, heat-resistant and self-extinguishing

#### material of contacts

gold-plated silver

#### switching element

soldering terminal: PA 6.6 Ultramid

### mechanical characteristics

#### actuating force

2-5.5 N, depending on the number of switching elements

#### actuating travel

3 mm

#### ambient air temperature

-25°C to +55°C

for indicators and illuminated pushbuttons mounted as a block, make sure the heat can escape freely (as per DIN IEC 68-)

#### connection method

snap-action switching element with tinned soldering terminals at the sides:

max. wire diameter: 2 wires à 1.2 mm

max. wire cross-section of stranded cable: 1x 1 mm<sup>2</sup>.

#### degree of protection

front as per IEC 529: IP 40

#### mechanical life

momentary action 2 mio. cycles of operation

maintained action 1 mio. cycles of operation

#### resistance to climate

standard condition as per IEC 68-2-3 and 2-30

changing condition as per IEC 68-2-14 and 2-33

#### resistance to shock

(single impacts, semi-sinusoidal)

15 g for 11 ms as per IEC 512-4-3, IEC 68-2-27

#### resistance to vibration

(sinusoidal)

10 g at 0-2000 Hz, amplitude 1.5 mm as per IEC 512-4-4, IEC 68-2-6

#### storage temperature

-40°C to + 85°C

(as per DIN IEC 68-)

### electrical characteristics

#### continuous thermal current Ith<sub>2</sub>

5 A

The maximum current in continuous operation and at ambient temperature not exceeding the quoted maximum values.

#### electric strength

2500 VAC, 50 Hz, 1 min. between all terminals and earth, as per IEC 512-2-11.

### protection class

II

### rated current

5 A

### rated voltage

250 VAC/VDC

### switch rating

250 VAC 5 A (cos φ 1)

250 VAC 3 A (cos φ 0.3)

switch rating AC, cos φ 0,7:

voltage 125 V 250 V

current 3 A 2 A

switch rating DC (inductive), L:R = 30 ms

voltage 24 V 60 V 110 V 220 V

current 2 A 0,7 A 0,2 A 0,1 A

### volume resistance

starting value (initial) ≤ 50 mOhm

### rules

IEC 1058 EN 61 058

### approvals

- SEV 250 VAC/5 A

- CSA 300 VAC

- UL

- VDE

### declaration of conformity

- CE

## actuator with Low Level switching element

### switching system

This low level switching element was designed for switching low powers in electronic circuits. The mechanism assures reliable switching of loads ranging from a few μA/μV up to 100 mA/42 VAC/VDC.

Single-break momentary contact, as normally open or normally closed with 4 independent points of contact. 2 momentary contacts per switching element; combination of normally open and normally closed is possible.

Special features are the long life, extremely short rebound time and stable contact resistance.

### material

#### actuator case

polysulfone, heat-resistant and self-extinguishing

#### material of contacts

gold-plated

#### switching element

polysulfone, heat-resistant and self-extinguishing

### mechanical characteristics

#### actuating force

3-3.5 N

#### actuating travel

3 mm

# Technical Data

## ambient air temperature

-25°C to +55°C

for indicators and illuminated pushbuttons mounted as a block ,  
make sure the heat can escape freely  
(as per DIN IEC 68-)

## connection method

The universal terminals permit these units to be mounted on printed  
circuit boards (PCB). These terminals can also be used as solde-  
ring or plug-in terminals.

For these terminals we can also supply a plug-in base which, when  
soldered on to the board, enables the switch to be plugged in.  
soldering terminal:

max. wire diameter: 2 wires of 0,8 mm

max. wire cross-section of stranded cable: 1x 0,75 mm<sup>2</sup>

plug-in terminal:

2,0 x 0,5 mm

## degree of protection

front as per IEC 529: IP 40

## mechanical life

momentary action 5 mio. cycles of operation

maintained action 1 mio. cycles of operation

## rebound time

Typ. < 100 µs

## resistance to climate

standard condition as per IEC 68-2-3 and 2-30

changing condition as per IEC 68-2-14 and 2-33

## resistance to shock

(single impacts, semi-sinusoidal)

15 g for 11 ms as per IEC 512-4-3, IEC 68-2-27

## storage temperature

-40°C to + 85°C

(as per DIN IEC 68-)

## electrical characteristics

### electric strength

2500 VAC, 50 Hz, 1 min. between all terminals and earth, as per IC  
512-2-11.

### protection class

II

### switch rating

10 µA/100 µV to 100 mA at 42 VAC/VDC

### volume resistance

starting value (initial) ≤ 50 mΩ

## technical drawing

### 1 indicator

page 63

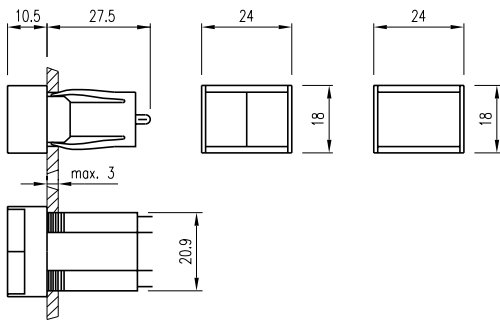

### 2 indicator, illuminated-/pushbutton

page 63, 64

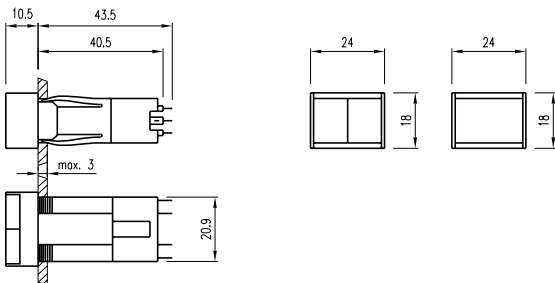

### 3 illuminated-/pushbutton

page 64

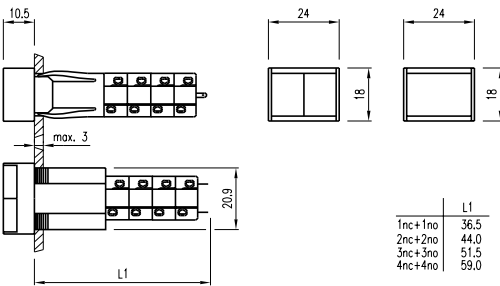

	L1
1nc+1no	36.5
2nc+2no	44.0
3nc+3no	51.5
4nc+4no	59.0

### 4 protective cover

page 66

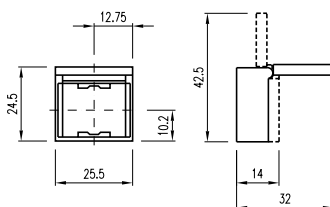

## mounting dimension

### 1 indicator, illuminated-/pushbutton, blind plug

page 63, 64, 66

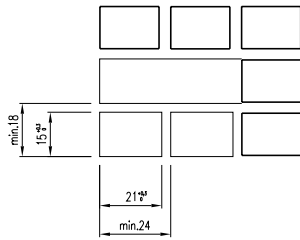

## components layouts

### 1 PCB plug-in base

page 66

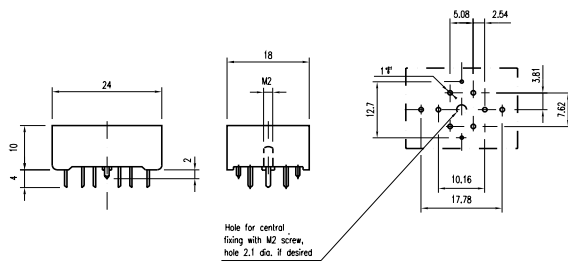

	circuit drawing
1	
2	
3	
4	
5	
6	
7	
8	
9	
10	
11	
12	
13	
14	
15	



## 1. Engraving

### Typefaces

In addition to the most commonly used world languages (see DIN 1451) with close spacing, the following typefaces are available: Scandinavian, Slavian, Greek, Russian.

### Coloured filling of engraving

Specify whether engraving should be on the diffuser, or on the lens.  
Specify the infill colour, character height and the text or symbol orientation.

### Symbols

A list of the symbols available can be supplied on request.

## 2. Hot stamping

For large batches it is worth while to have the lettering produced by hot stamping.

### Typefaces

For letters and figures, typefaces with 2,5 mm, 3 mm and 4 mm are available.

### Symbols

A list of the symbols available can be supplied on request.

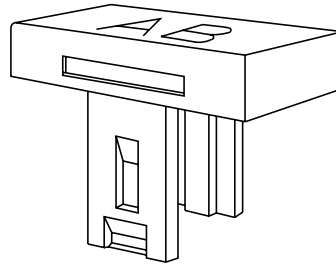

## 3. Film inserts

Instead of using engraving, the lenses can be fitted with transparent film inserts.

For this purpose, though, it is advisable to use transparent lenses.

To insert the film, the feet of the lens support have to be pushed together far enough to enable the lens to be lifted off easily.

### Film dimensions

max. 12,7 x 18,7 mm (monocolour lens)  
max. 9 x 12,7 mm (two-colour lens)

### Film thickness 0,2 mm

### Important!

Before engraving, check the position of the illuminated pushbuttons or indicator.

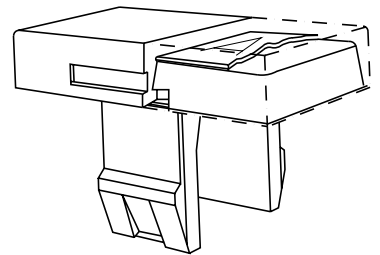

Height of letters mm	Thickness of letters mm	Horizontal mounting			Vertical mounting			Horizontal mounting			Vertical mounting		
		Number of lines	Number of letters per line	Number of letters per line	Number of lines	Number of letters per line	Number of letters per line	Number of lines	Number of letters per line	Number of letters per line	Number of lines	Number of letters per line	Number of letters per line
h	s		(caps)	(small)		(caps)	(small)		(caps)	(small)		(caps)	(small)
2,5	0,4	4	11	12	5	7-8	8	4	5-6	5-6	2	7-8	8
3	0,4	3	9-10	10-11	4	6-7	7	3	4-5	5	2	6-7	7
4	0,5	2	7	7-8	3	4-5	5	2	3	3-4	1	4-5	5
5	0,5	2	5-6	6	2	3-4	4	2	2-3	3	1	3-4	4
6	0,6	1	4-5	5	2	3	3-4	1	2	2-3	1	3	3-4
8	0,6	1	3-4	3-4	1	2-3	2-3	1	1-2	1-2	1	2-3	2-3